

STATE OF ILLINOIS  
DEPARTMENT OF TRANSPORTATION

ROUTE NO. F. A. I. 80/94	SECTION •	COUNTY COOK	TOTAL SHEETS 90	SHEET NO. 74	SHEET NO. 17 21 SHEETS
FED. ROAD DIST. NO. 1 ILLINOIS FED. AID PROJECT-			CONTRACT NO. 62898		

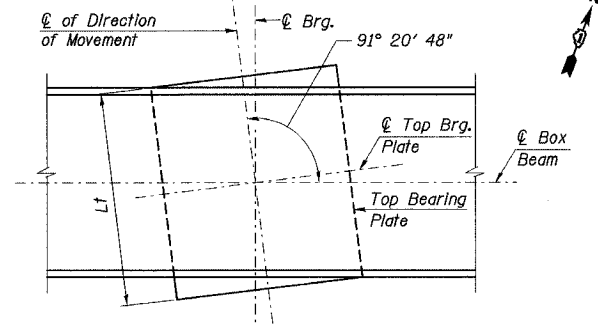

**SECTION A-A**

(Brg. at Center Column shown; East Column and West Column Brg. similar)

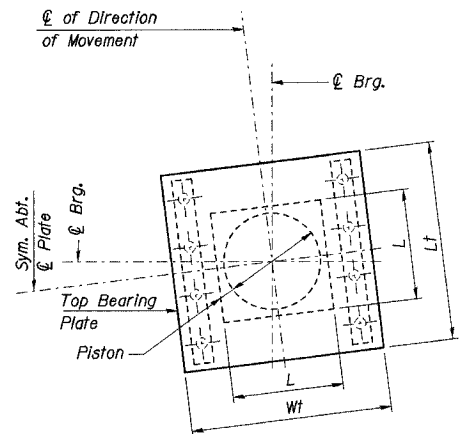

**TOP BEARING PLATE AND PISTON PLAN**

Note: Plate and piston are parallel to  $\phi$  of Direction of movement and not perpendicular to  $\phi$  Box Beam Orientation Angle provided in section A-A

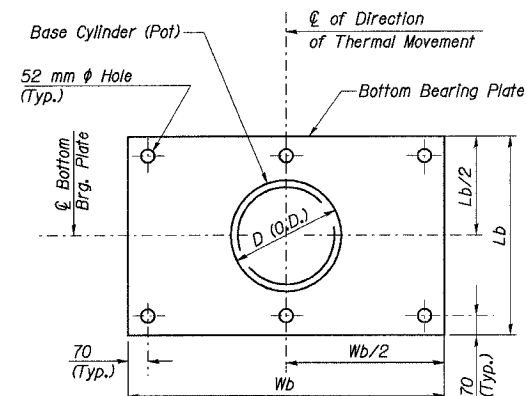

**BOTTOM BEARING PLATE AND BASE CYLINDER PLAN**

(Center Column)  
Note: Plate and piston are parallel to  $\phi$  of Direction of movement and not perpendicular to  $\phi$  Box Beam Orientation Angle provided in Section A-A

DESIGNED	JFA
CHECKED	JJK
DRAWN	LK
CHECKED	JJK

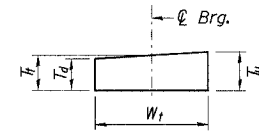

**TOP PLATE BEVEL DETAIL**

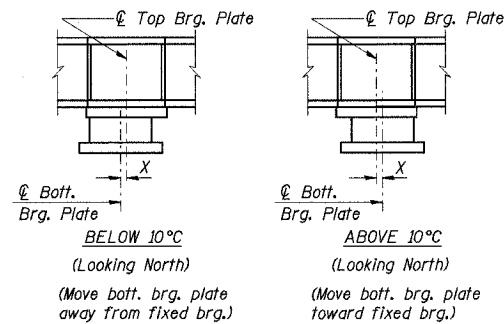

**ANCHOR BOLT SETTING DETAILS AT EXPANSION BEARINGS**

X=1 mm per each 10 m of expansion for every 8 °C temperature change from the normal temp. of 10 °C

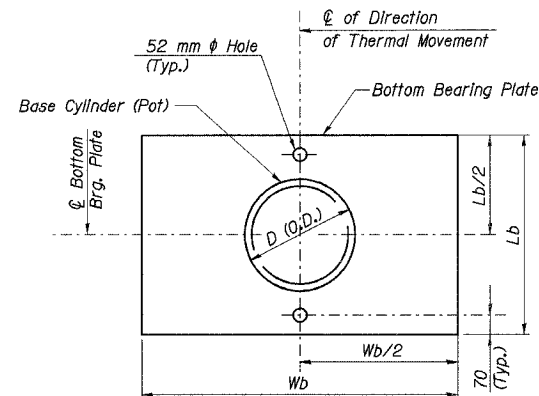

**BOTTOM BEARING PLATE AND BASE CYLINDER PLAN**

(East and West Column)  
Note: Plate and piston are parallel to  $\phi$  of Direction of movement and not perpendicular to  $\phi$  Box Beam Orientation Angle provided in Section A-A

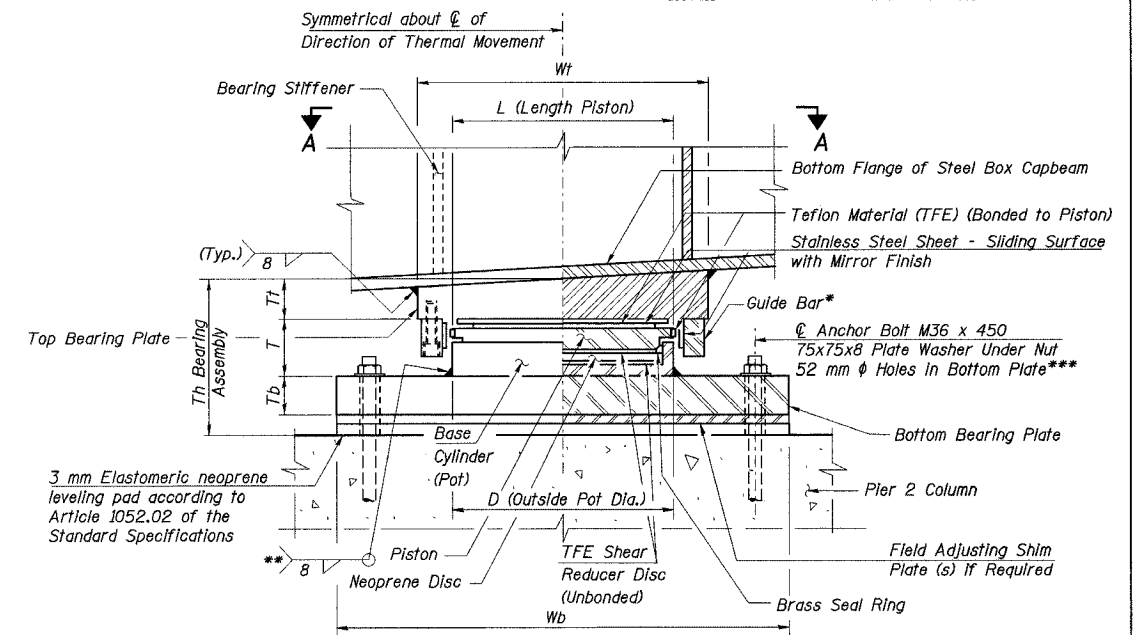

**HALF SECTION THRU GUIDED EXPANSION BEARING**

Note: Th & Tt are measured at  $\phi$  Bearing.  
Th includes 3mm elastomeric neoprene mat.

\* As alternatives to the bolted connection shown, the guide bars may be connected to the top bearing plate by groove welds or the guide bars and top bearing plate may be fabricated as a single piece.

\*\* Weld may be omitted if base cylinder is recessed into bottom bearing plate.

\*\*\*Note: North and South Column anchor bolts are A307 and Center Column anchor bolts are A325. See Note 4.

**BEARING ASSEMBLY DIMENSIONS**

Member	Dimension	Location		
		S. Col.	Center Col.	N. Col.
Top Plate	Wt	460	1050	440
	Lt	900	1075	900
	Td	70	152	64
	Tt	84	183	77
	Tu	98	215	90
Bearing	D	315	765	290
	L	315	765	290
	T	85	180	80
	T	85	180	80
Bottom Plate	Wb	510	1000	485
	Lb	1100	1255	1100
	Tb	85	106	85
Bearing Assembly	Th	257	472	245

**BEARING DESIGN INFORMATION**

Design Information	Location		
	S. Col.	Center Col.	N. Col.
Vertical Design Load (kN)	1166	7706	975
Pay Item Size (kN)	1250	8000	1250
Total Required Movement (mm)	41	41	41

Note:  
Vertical Design Load = Total Vertical Dead Load + Live Load (No Impact)

**BILL OF MATERIAL**

ITEM	UNIT	QUANTITY
Furnishing Floating Bearings, Guided Expansion, 1,250 kN	Each	2
Furnishing Floating Bearings, Guided Expansion, 8,000 kN	Each	1

**Notes:**

- All dimensions are in millimeters (mm) except as shown.
- The structural steel for the top and bottom bearing plates shall be AASHTO M 270M Grade 345.
- Cost of top and bottom bearing plates, 3mm Elastomeric Neoprene, shim plates and threaded studs with washer shall be included with Furnishing Floating Bearings.
- For anchor bolt type and details, see Anchor Bolt Details Sht. No. 21 of 21 Shts.

ILLINOIS DEPARTMENT OF TRANSPORTATION  
I-94 EAST BOUND / IL 394 SOUTH BOUND

**PIER 2 BEARING DETAILS**

EB I-94 OVER THORN CREEK  
F.A.I. 94 SECTION 2004-133F  
COOK COUNTY  
STA. 20+509.000 STRUCTURE NO. 016-2807

DATE 05/16/05  
SCALE ---

**HNTB**

I:\cadd\2004\EB I-94\SN\_2807\cadd\CTR\_29\_2807\st190806-4a\_2807.dgn  
 20-1411-2805 1:431