

STATE OF ILLINOIS
DEPARTMENT OF TRANSPORTATION

ROUTE NO.	SECTION	COUNTY	TOTAL SHEETS	SHEET NO.
FAI 90/94	*	COOK	93	52
FED. ROAD DIST. NO.	ILLINOIS	FED. AID PROJECT		

SHEET NO. 5
8 SHEETS

* 2005 - 008F
Contract #62919

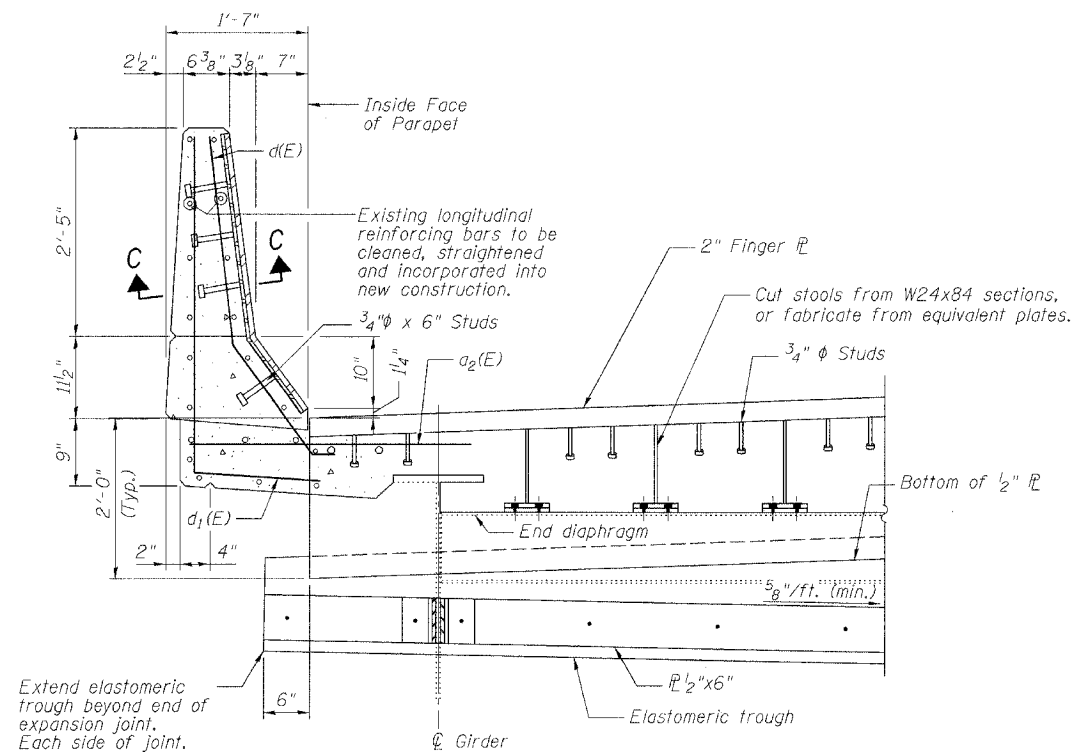

SECTION B-B

(For location of Section B-B, See Sheet 4 of 8)

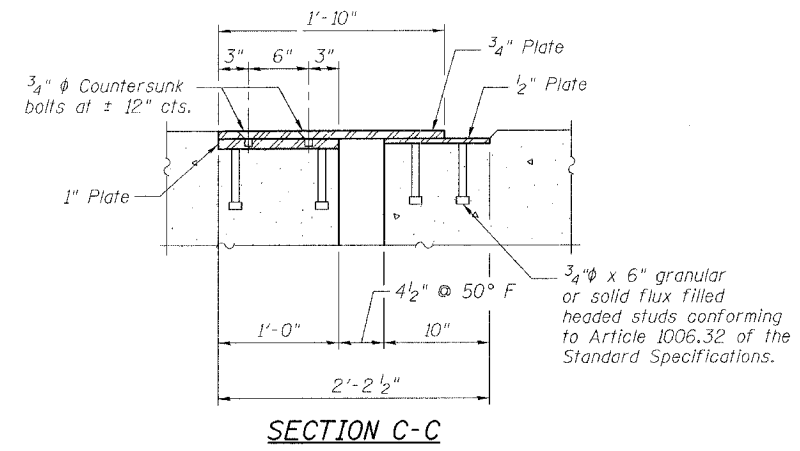

SECTION C-C

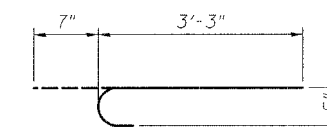

BAR b(E)

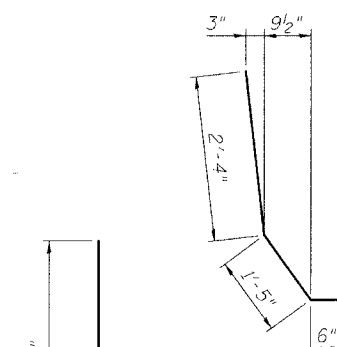

BAR d(E)

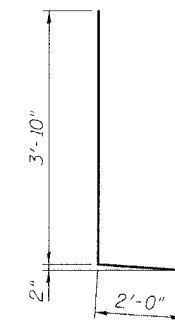

BAR d1(E)

BILL OF MATERIAL

Bar	No.	Size	Length	Shape
d(E)	24	#5	18'-6"	—
d1(E)	24	#5	20'-6"	—
a2(E)	16	#6	4'-6"	—
b(E)	80	#5	3'-10"	⌋
d(E)	16	#5	4'-3"	⌋
d1(E)	20	#5	5'-10"	⌋
Reinforcement Bars, Epoxy Coated			Pound	1600
Concrete Superstructure			Cu. Yd.	11.2
Concrete Removal			Cu. Yd.	9.4
Bar Splicers			Each	24
Mechanical Splice			Each	80

Reinforcing bars designated (E) shall be epoxy coated.

REVISIONS	
NAME	DATE

ILLINOIS DEPARTMENT OF TRANSPORTATION
PARAPET DETAILS
F.A.I. ROUTE 90/94 NORTHBOUND (DAN RYAN EXPRESSWAY)
OVER SOUTH BRANCH - CHICAGO RIVER
COOK COUNTY
S.N. 016-1113 - PIER C10

SCALE: VERT. _____
HORIZ. _____
DATE: 2/17/05

DRAWN BY: HEBERLING
DESIGNED BY: SANFORD
CHECKED BY: _____

GREENE & BRADFORD, INC.
OF SPRINGFIELD
CONCRETE REINFORCEMENT
CONSTRUCTION, INC.
PROFESSIONAL ENGINEERS
REGISTERED UNDER THE ACT OF 1927
PROFESSIONAL & STRUCTURAL ENGINEERING CORPORATION
1011 N. 3RD ST., CHICAGO, ILL. 60610

COMPUTER FILE NO.
04286-W04-PD
PROJECT 04286-W04
6/15/05-MML

FILE NAME = \$FILE\$
PLOT SCALE = \$PLOTSCALE\$
PLOT DATE = 6/22/2005
PLOT TIME = 12:13:39 PM
OPERATOR = mictel@ellie1