

F.A.I. RTE.	SECTION	COUNTY	TOTAL SHEETS	SHEET NO.
412	(50-5B)I-1	LASALLE	29	1

INDEX OF SHEETS

1. COVER SHEET
2. GENERAL NOTES
3. SUMMARY OF QUANTITIES
4. PLAN & ELEVATION
5. DECK RECONSTRUCTION DETAILS - CROSS SECTIONS
6. CONCRETE REMOVAL - NORTH ABUTMENT DECK DETAILS
7. CONCRETE REMOVAL - NORTH ABUTMENT PARAPET DETAILS
8. CONCRETE REMOVAL - SOUTH ABUTMENT DECK DETAILS
9. CONCRETE REMOVAL - SOUTH ABUTMENT PARAPET DETAILS
10. RECONSTRUCTION - NORTH ABUTMENT DECK DETAILS
11. RECONSTRUCTION - NORTH ABUTMENT PARAPET DETAILS
12. RECONSTRUCTION - SOUTH ABUTMENT DECK DETAILS
13. RECONSTRUCTION - SOUTH ABUTMENT PARAPET DETAILS
14. STRIP SEAL EXPANSION JOINT DETAILS
15. PPC DECK BEAM REPAIR
16. PPC DECK BEAM REPAIR
17. PARAPET WALL REPAIR
18. ABUTMENT WALL REPAIR
19. BEARING REPLACEMENT DETAILS
20. BEARING REPLACEMENT DETAILS
21. ANCHOR BOLT DETAIL FOR BEARINGS
22. DECK DRAIN EXTENSION DETAILS
23. BAR SPLICER ASSEMBLY DETAILS
24. PRE-STAGING DETAILS
25. TRAFFIC CONTRL. AND PROTECTION, STANDARD 701402 (SPECIAL)
26. STAGING AND TRAFFIC CONTRL. - TYPICALS
27. TEMPORARY CONCRETE BARRIER - STAGE I
28. TEMPORARY CONCRETE BARRIER - STAGE II
29. TYPICAL PAVEMENT MARKING

MICROFILMED \_\_\_\_\_  
 REEL NUMBER \_\_\_\_\_  
 AWARDED \_\_\_\_\_  
 RESIDENT ENGINEER \_\_\_\_\_  
 AS BUILT CHANGES WERE MADE  
 ON THE FOLLOWING SHEETS \_\_\_\_\_

JULIE 1-800-892-0123

DISTRICT 3 NO. (815) 434-6131

PROJECT ENGINEER: TOM HUFNAGEL (815) 434-8418  
 UNIT CHIEF: RON WOODSHANK (815) 434-8419

CONTRACT NO. 66570

STATE OF ILLINOIS  
 DEPARTMENT OF TRANSPORTATION  
 DIVISION OF HIGHWAYS

**PROPOSED  
 HIGHWAY PLANS**

FAI ROUTE 412 (I-39)  
 SECTION (50-5B)I-1

LASALLE COUNTY  
 C-93-076-05  
 BRIDGE REPAIR

PROJECT LOCATION  
 SN 050-0174  
 FAI 412 (I-39) NORTHBOUND  
 OVER A CREEK  
 3.5 mi NORTH OF I-80

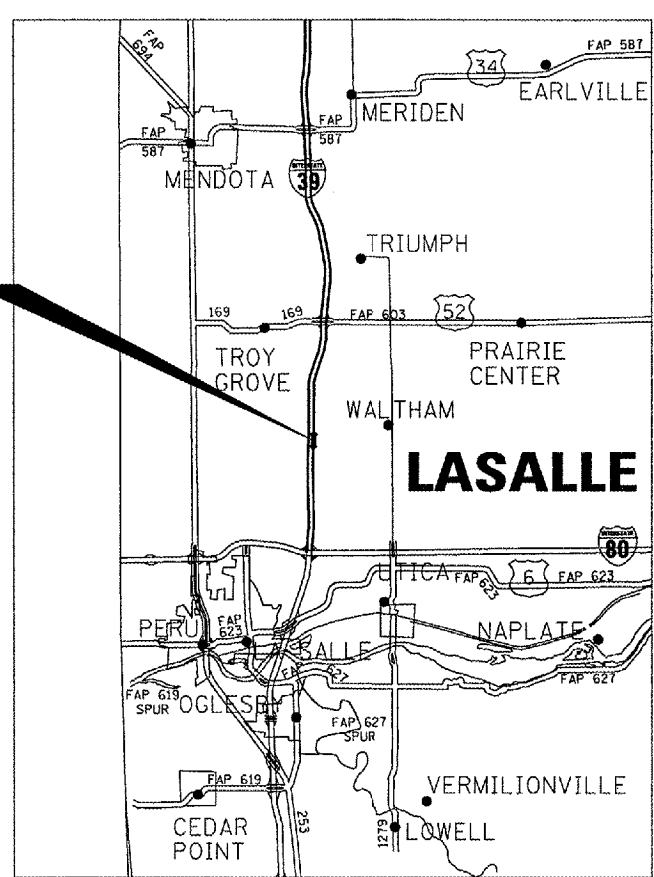

LOCATION MAP  
 NOT TO SCALE

GROSS LENGTH OF PROJECT = SB: 136 FEET 0.03 MI  
 NET LENGTH OF PROJECT = SB: 136 FEET 0.03 MI

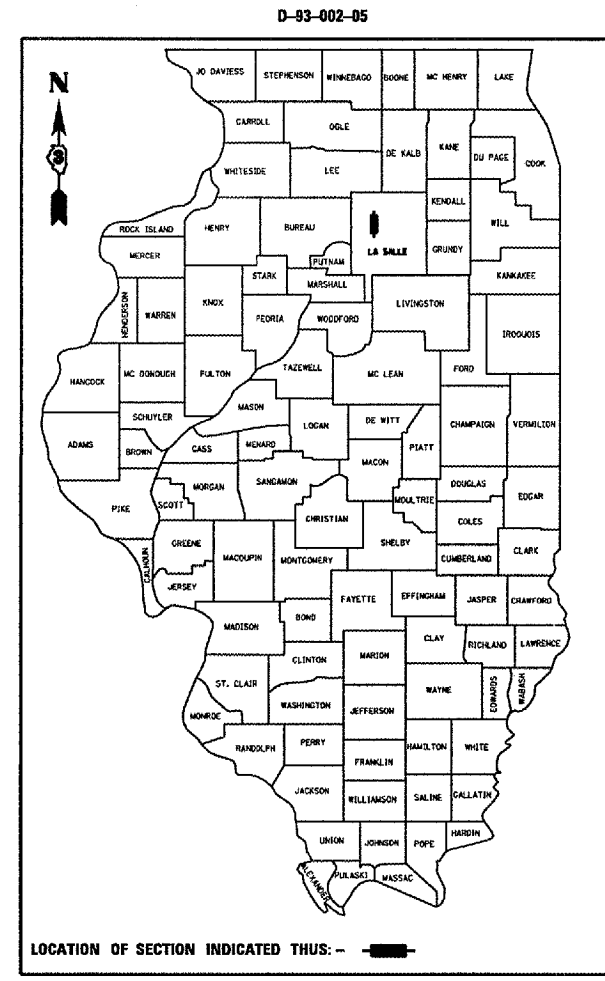

LOCATION OF SECTION INDICATED THUS: -

STATE OF ILLINOIS  
 DEPARTMENT OF TRANSPORTATION  
 DIVISION OF HIGHWAYS

SUBMITTED 9/19 2005  
Gregory Moutch  
 DEPUTY DIRECTOR OF HIGHWAYS, REGION ENGINEER

July 1 2005  
Mike Hine  
 ENGINEER OF DESIGN AND ENVIRONMENT

July 1 2005  
Walter Mader  
 DIRECTOR OF HIGHWAYS, CHIEF ENGINEER

PRINTED BY THE AUTHORITY  
 OF THE STATE OF ILLINOIS

MARCH 30, 2005  
 C:\PROJECTS\CMA\ING\CM303\DETAILS.DGN

F.A.I. RTE.	SECTION	COUNTY	TOTAL SHEETS	SHEET NO.
412	(50-5B)I-1	LASALLE	29	2
FED. ROAD DIST. NO. . ILLINOIS		STATE AID PROJECT		

**GENERAL NOTES:**

Plan dimensions and details relative to the existing roadway and structure have been taken from existing plans and are subject to nominal construction variations. It shall be the contractor's responsibility to verify such dimensions and details in the field and to make necessary approved adjustments prior to construction or ordering of materials. Such variations shall not be cause for additional compensation for a change in the scope of the work, however, the contractor will be paid for the quantity actually furnished at the unit price bid for the work.

The contractor shall be responsible for protecting utility property from construction operations as outlined in Article 107.31 of the Standard Specifications. The "Julte" Number is 1-800-892-0123. A minimum of forty-eight (48) hours advance notice is required.

The cost of any saw cuts made to complete the work as described in plan details, unless otherwise noted shall not be paid for separately but shall be included in the various pay items involved.

Where section or subsection monuments are encountered, the engineer shall be notified before such monuments are removed. The contractor shall protect and carefully preserve all monuments until an authorized surveyor or agent has witnessed or otherwise referenced their location. The contractor shall be responsible for having an authorized surveyor reestablish any section or subsection monuments destroyed by his operations.

Any reference to a standard in these plans shall be interpreted to mean the edition as indicated by the subnumber listed on the index of sheets or the copy of the standard included in these plans.

New Reinforcement bars shall be Epoxy Coated.

Reinforcement bars that are to remain in place which are damaged during concrete removal operations shall be repaired or replaced using approved bar splicer or anchorage system. Cost included with "Concrete Removal".

All structural steel shall be AASHTO M 270 Grade 50 except expansion joint plates and attached bars which shall be AASHTO M 270 Grade 36.

Anchor Bolts shall be high strength bolts (AASHTO M 164, Type3). 1/2" dia. open holes for 1" dia. bolts.

Expansion joint plates and attached bars shall be shop painted with the inorganic zinc rich primer.

Reinforcement bars shall conform to the requirements of AASHTO M 31 or M322 Grade 60.

**STANDARDS**

- 000001-04 STANDARD SYMBOLS, ABBREVIATIONS AND PATTERNS
- 001001 AREAS OF REINFORCEMENT
- 001006 DECIMAL OF AN INCH AND OF A FOOT
- 483001-02 PCC SHOULDER
- 609001-02 BRIDGE APPROACH SHOULDER PAVEMENT AND DRAIN
- 635011-01 REFLECTOR MARKER AND MOUNTING DETAILS
- 701101-01 OFF-ROAD OPERATIONS, MULTILANE, 4.5 m (15') TO 600mm (24") FROM EDGE OF PAVEMENT
- 701106-01 OFF-ROAD OPERATIONS, MULTILANE, MORE THAN 4.5 m (15') AWAY
- 701400-02 APPROACH TO LANE CLOSURE, FREEWAY/EXPRESSWAY
- 702001-05 TRAFFIC CONTROL DEVICES
- 704001-02 TEMPORARY CONCRETE BARRIER

DATE: May 18, 2005

PREPARED BY: *Bruce A. Anderson*  
DISTRICT OPERATIONS ENGINEER

EXAMINED BY: *Hubert K. [Signature]*  
DISTRICT CONSTRUCTION ENGINEER

*Thomas B. [Signature]*  
ACTING DISTRICT STUDIES & PLANS ENGINEER

*Kenneth R. [Signature]*  
DISTRICT MATERIALS ENGINEER

REVISIONS	
NAME	DATE

ILLINOIS DEPARTMENT OF TRANSPORTATION  
**GENERAL NOTES**  
S.N. 050-0173  
F.A.I. 412 SOUTHBOUND  
OVER C. & N.W. RAILROAD  
SECTION (50-5B)I  
STA. 1216 + 43.45  
DRAWN BY RW  
CHECKED BY  
DATE 04/24/2005

MARCH 30, 2005  
C:\PROJECTS\CMA IN06\CM303\DATA\LS.DGN

CONTRACT NO. 66570				
F.A.I. RTE.	SECTION	COUNTY	TOTAL SHEETS	SHEET NO.
412	(50-5B)I-1	LASALLE	29	3
FED. ROAD DIST. NO.		ILLINOIS	STATE AID PROJECT	

## SUMMARY OF QUANTITIES

CONSTRUCTION CODE TYPE: **X081-2A**

CODE NO.	ITEM	UNIT	RURAL 100% STATE TOTAL QUANTITY
31101900	SUB-BASE GRANULAR MATERIAL, TYPE C	TON	200
42001500	<b>PCC BRIDGE APPROACH SHOULDER PAVT</b>	SQ YD	45
44000910	BITUMINOUS CONCRETE REMOVAL (DECK)	SQ YD	575
44001430	BITUMINOUS SHOULDER REMOVAL	SQ YD	1714
48300500	PCC SHOULDER 10"	SQ YD	1708
50102400	CONCRETE REMOVAL	CU YD	31.2
50300255	CONCRETE SUPERSTRUCTURE	CU YD	31.2
50301245	FORMED CONCRETE REPAIR (DEPTH EQUAL TO OR LESS THAN 5")	SQ FT	157
50500725	JACK AND REPLACE BEARINGS	EACH	12
50800205	REINFORCEMENT BARS, EPOXY COATED	POUND	6354
60260100	INLETS TO BE ADJUSTED	EACH	2
67000400	ENGINEER'S FIELD OFFICE, TYPE A	CAL MO	5
67100100	MOBILIZATION	L SUM	1
70100305	TRAFFIC CONTROL AND PROTECTION, STANDARD 701400	L SUM	1
70101605	TRAFFIC CONTROL AND PROTECTION, STANDARD 701402 (SPECIAL)	EACH	1
70300220	TEMPORARY PAVEMENT MARKING - LINE 4"	FOOT	1580
70301000	WORK ZONE PAVEMENT MARKING REMOVAL	SQ FT	521
70400100	TEMPORARY CONCRETE BARRIER	FOOT	555
70400200	RELOCATE TEMPORARY CONCRETE BARRIER	FOOT	555
78005110	EPOXY PAVEMENT MARKING - LINE 4"	FOOT	1580
78005130	EPOXY PAVEMENT MARKING - LINE 6"	FOOT	34
78300100	PAVEMENT MARKING REMOVAL	SQ FT	521
XX005128	STRIP SEAL EXPANSION JOINT ASSEMBLY	FOOT	85
XZ191205	BRIDGE DECK MICROSILICA CONCRETE OVERLAY 3"	SQ YD	519
X0300136	BRIDGE APPROACH SHOULDER REMOVAL	SQ YD	29
X0322194	POLYMER MODIFIED PORTLAND CEMENT MORTAR	SQ FT	29
X0322379	CONCRETE SEALER	SQ YD	73
X0322905	PCC I-BEAM REPAIRS	L SUM	1
Z0002600	BAR SPLICER	EACH	38
Z0006205	BRIDGE DECK HYDRO-SCARIFICATION 1 1/2"	SQ YD	519
Z0015595	DECK DRAIN EXTENSIONS	EACH	3
* Z0030250	IMPACT ATTENUATOR, TEMPORARY, NON-REDIRECTIVE, TEST LEVEL 3	EACH	1
* Z0047300	<b>PROTECTIVE SHIELD</b>	SQ YD	112
* Z0030350	IMPACT ATTENUATOR, RELOCATE, NON-REDIRECTIVE, TEST LEVEL 3	EACH	1

\* SFTY-3N

REVISIONS	
NAME	DATE

ILLINOIS DEPARTMENT OF TRANSPORTATION

**SUMMARY OF QUANTITIES**  
**S.N. 050-0174**  
 F.A.I. 412 NORTHBOUND  
 OVER C. & N.W. RAILROAD  
 SECTION (50-5B)I-1  
 STA. 1216 + 43.45

DATE 04/24/2005

DRAWN BY RW  
 CHECKED BY

MARCH 30, 2005  
 C:\PROJECTS\CMA\ING6\CM303\DETA\LS.DGN

CONTRACT NO. 66570			
F.A.I. RTE.	SECTION	COUNTY	TOTAL SHEET NO.
412	(50-5B)I-1	LASALLE	29 4
FED. ROAD DIST. NO.	ILLINOIS	STATE AID PROJECT	

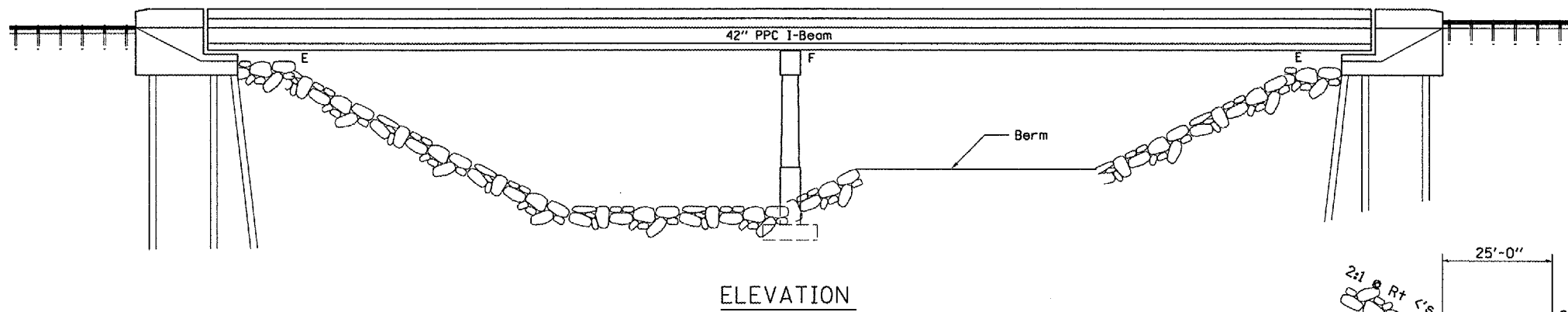

ELEVATION

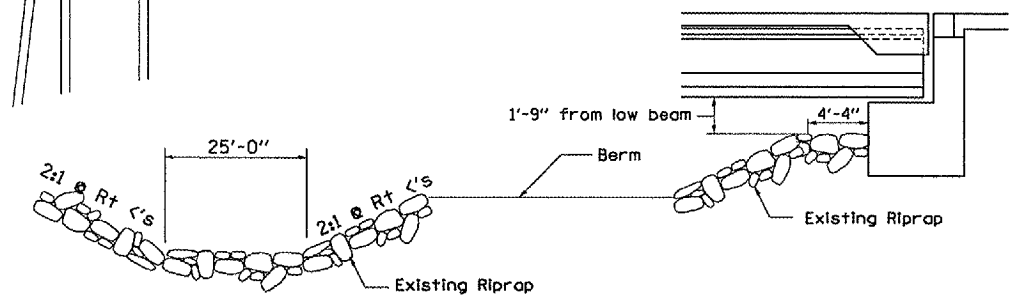

SECTION THRU CHANNEL

SECTION THRU ABUTMENT

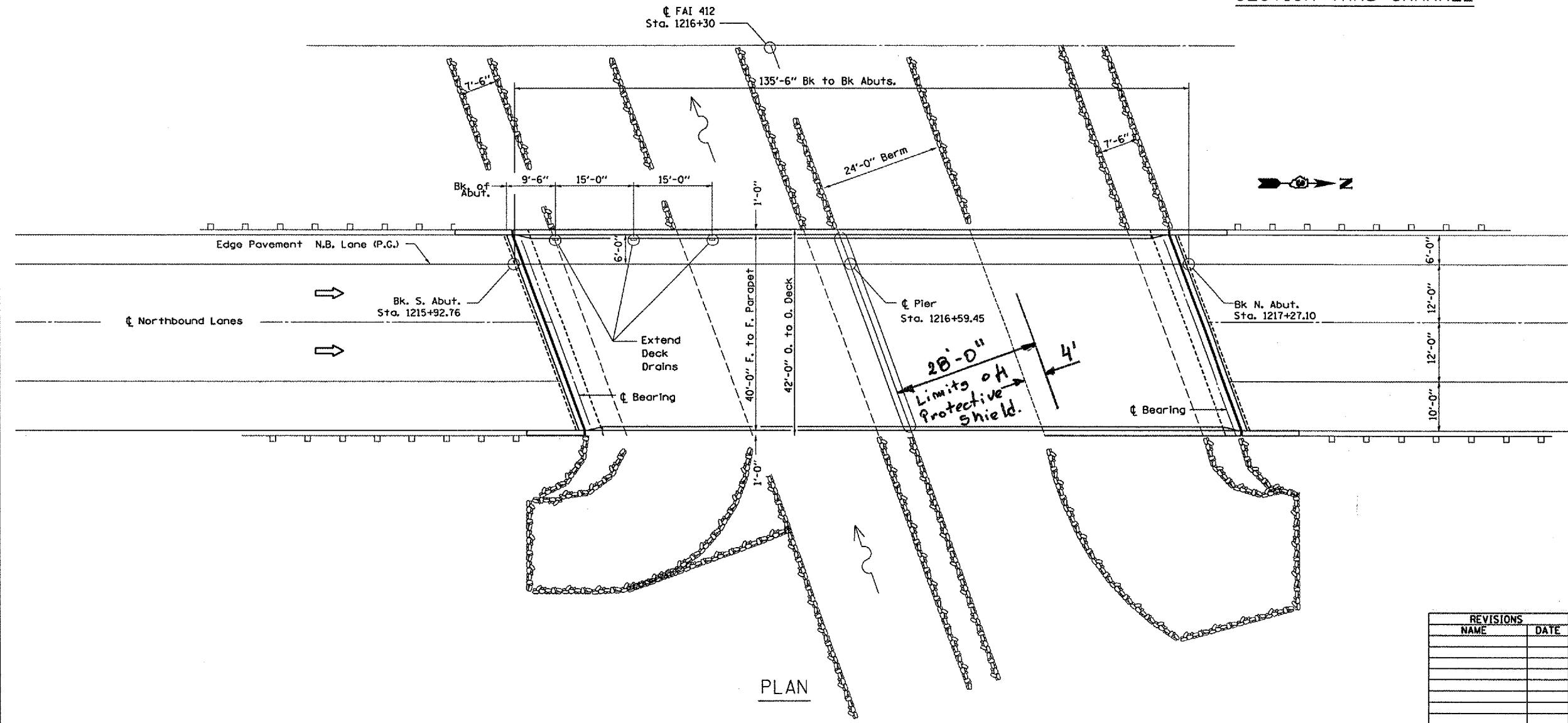

PLAN

REVISIONS	
NAME	DATE

ILLINOIS DEPARTMENT OF TRANSPORTATION  
**PLAN & ELEVATION**  
 S.N. 050-0174  
 F.A.I. 412 NORTHBOUND  
 OVER C. & N.W. RAILROAD  
 SECTION (50-5B)I-1  
 STA. 1216+43.45  
 DATE 04/24/2005  
 DRAWN BY RW  
 CHECKED BY

MARCH 30, 2005  
 C:\PROJECTS\CMA IN06\CM303\DETA\LS.DGN

CONTRACT NO. 66570				
F.A.I. RTE.	SECTION	COUNTY	TOTAL SHEETS	SHEET NO.
412	(50-5B)I-1	LASALLE	29	5
FED. ROAD DIST. NO.	ILLINOIS	STATE AID PROJECT		

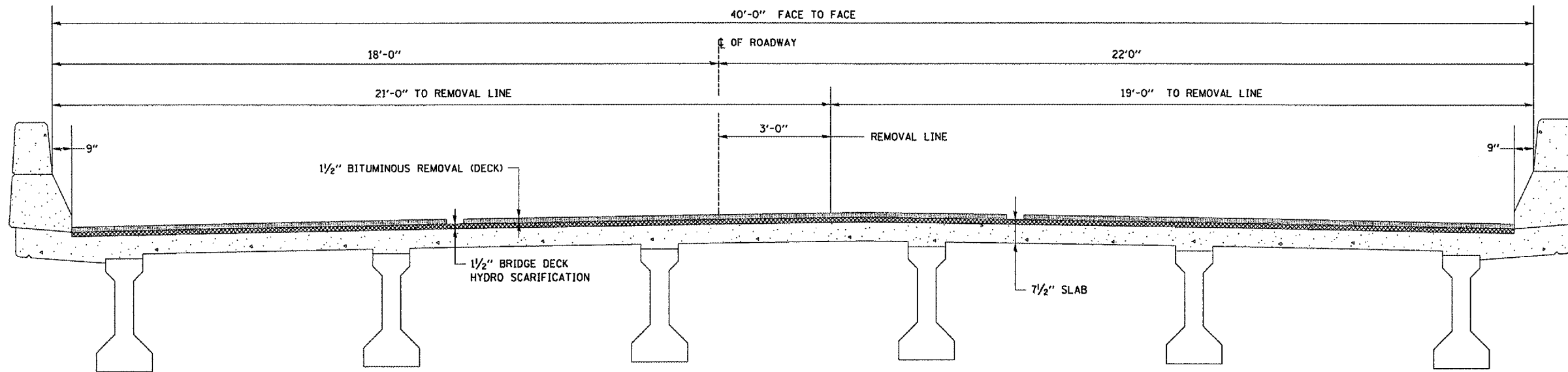

EXISTING CROSS SECTION  
Looking North

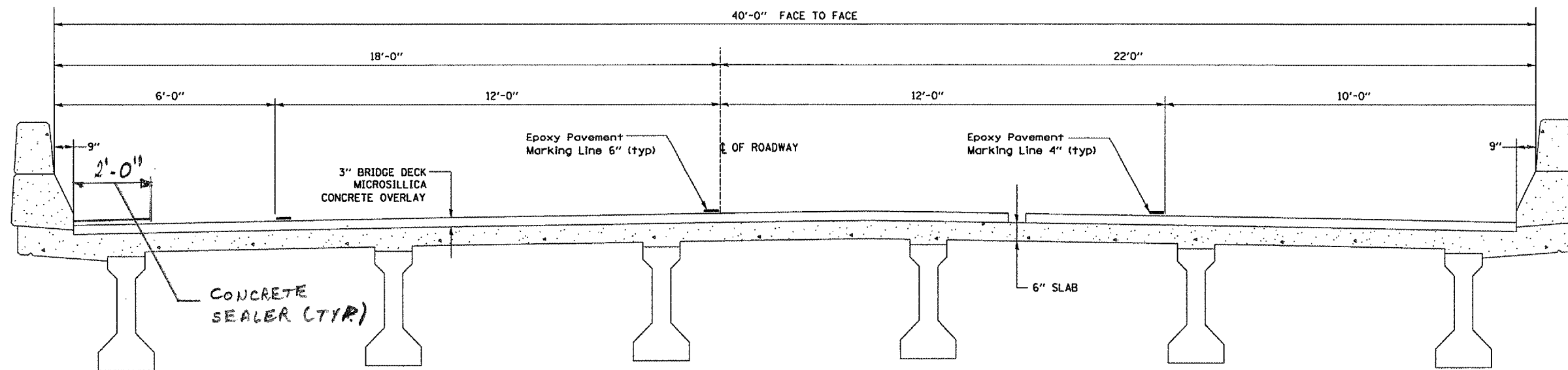

PROPOSED CROSS SECTION  
Looking North

REVISIONS	
NAME	DATE

ILLINOIS DEPARTMENT OF TRANSPORTATION  
**DECK RECONSTRUCTION DETAILS**  
 CROSS SECTIONS  
 S.N. 050-0174  
 F.A.I. 412 NORTHBOUND  
 OVER C. & N.W. RAILROAD  
 SECTION (50-5B)I-1  
 STA. 1216+43.45  
 DATE 04/24/2005  
 DRAWN BY RW  
 CHECKED BY

MARCH 30, 2005  
C:\PROJECTS\CMA\106\CM303\DETAILS.DGN

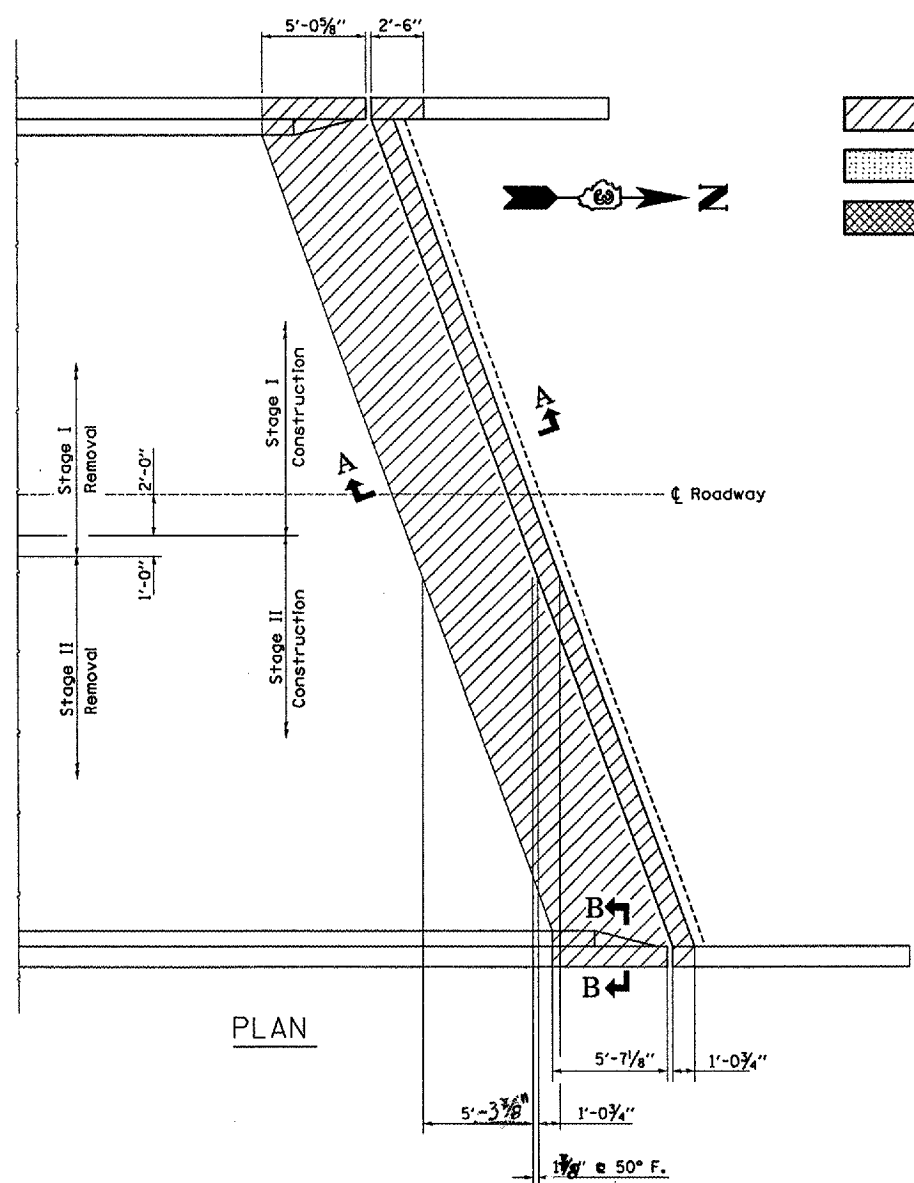

- CONCRETE REMOVAL
- BITUMINOUS REMOVAL (DECK)
- BRIDGE DECK HYDRO-SCARIFICATION

**Minimum Bar Lap**

- #4 1'-8"
- #5 2'-2"
- #6 2'-7"
- #7 3'-5"
- #8 4'-6"

**GENERAL NOTES:**

Plan dimensions and details relative to the existing roadway and structure have been taken from existing plans and are subject to nominal construction variations. It shall be the contractor's responsibility to verify such dimensions and details in the field and to make necessary approved adjustments prior to construction or ordering of materials. Such variations shall not be cause for additional compensation for a change in the scope of the work, however, the contractor will be paid for the quantity actually furnished at the unit price bid for the work.

Two coats of an approved Bridge Seat Sealer shall be applied to the deck and face of parapet to the limits shown on plan details. Cost of this work shall be paid for per sq yd for "Concrete Sealer".

New Reinforcement bars shall be Epoxy Coated.

Reinforcement bars that are to remain in place which are damaged during concrete removal operations shall be replaced using approved bar splicer or anchorage system. Cost included with "Concrete Removal".

The roadway expansion plates shall be flame cut as provided in Article 505.04(k) of the Standard Specifications.

Expansion guards shall be fabricated and erected according to Article 503.10(c) of the Standard Specifications and are included in the quantity of "Bridge Expansion Joint System".

All expansion joint plates and attached bars shall be AASHTO M 270 Grade 36

Expansion joint plates and attached bars shall be shop painted with the Inorganic zinc rich primer.

Anchor bolts, High Strength Steel Bolts, Nuts and washers shall conform to the requirements of Article 1006.08 and Article 1006.09 of the Standard Specifications.

Reinforcement bars shall conform to the requirements of AASHTO M 31 or M322 Grade 60.

Existing reinforcement extending into the concrete removal area shall be cut to provide the required bar lap for the size of bar as shown. All other reinforcement shall be removed and replaced with new Epoxy Coated bars.

The Contractor shall exercise care during concrete removal operations so the existing PPC Beams are not damaged. If the beams are damaged due to the Contractor's operations, they shall be repaired to the satisfaction of the Engineer at no expense to the department.

Removal of existing expansion joint steel, anchor studs, expansion material shall be paid for separately but shall be included in the cost of "Concrete Removal".

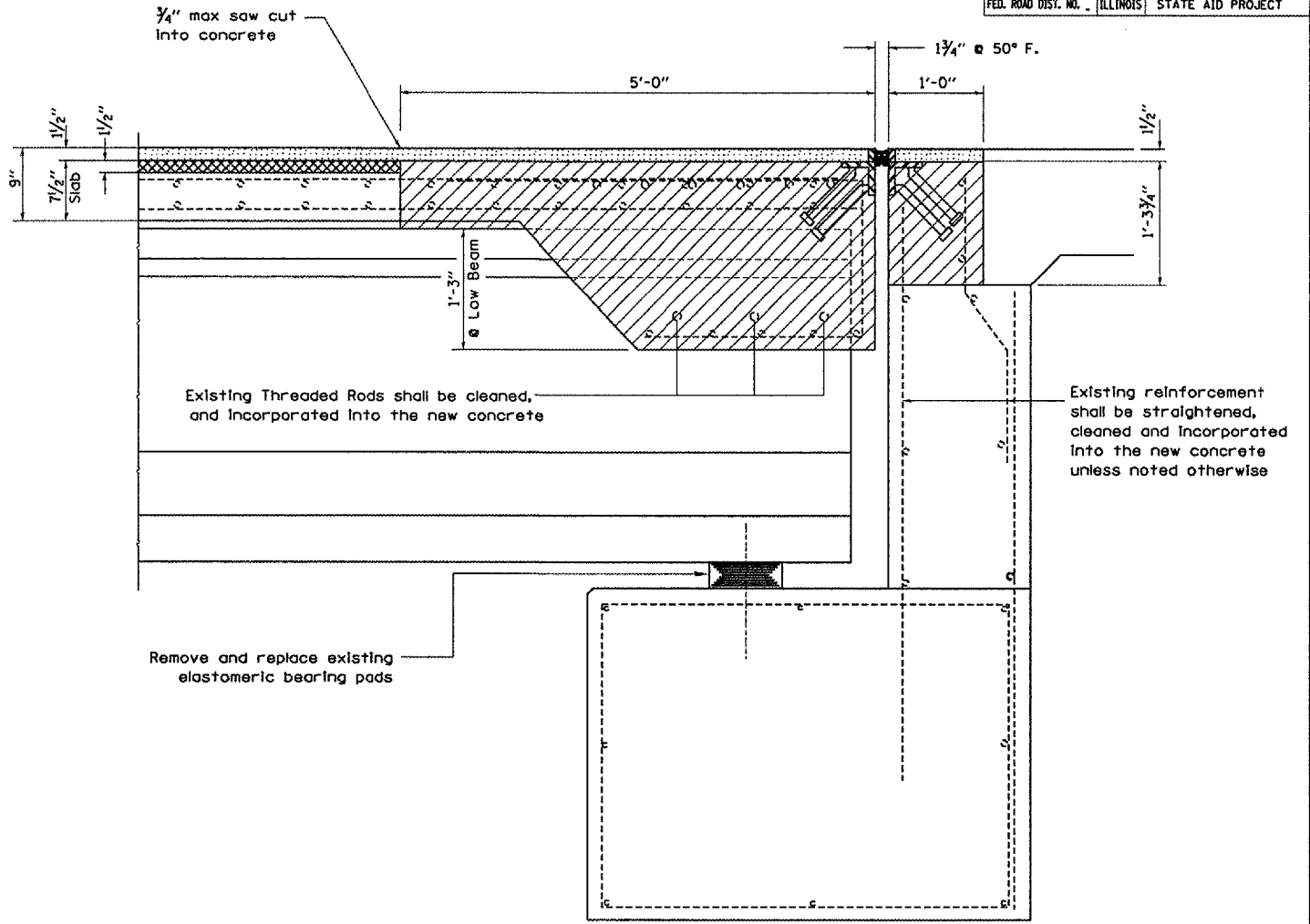

**SECTION A-A**  
@ Rt <'s

**BILL OF MATERIAL NORTH ABUTMENT**

Item	Unit	Total
CONCRETE REMOVAL	CU. YD.	15.7
JACK AND REPLACE BEARINGS	EACH	6

REVISIONS	
NAME	DATE

ILLINOIS DEPARTMENT OF TRANSPORTATION  
**CONCRETE REMOVAL-NORTH ABUT.**  
**DECK DETAILS**  
 S.N. 050-0174  
 F.A.I. 412 NORTHBOUND  
 OVER C. & N.W. RAILROAD  
 SECTION (50-5B)I-1  
 STA. 1216 + 43.45  
 DATE 04/24/2005  
 DRAWN BY RW  
 CHECKED BY

MARCH 30, 2005 C:\PROJECTS\CMA\IN06\CM303\DETAILS.DGN

F.A.I. RTE.	SECTION	COUNTY	TOTAL SHEETS	SHEET NO.
412	(50-5B)I-1	LASALLE	29	7
FED. ROAD DIST. NO. ILLINOIS		STATE AID PROJECT		

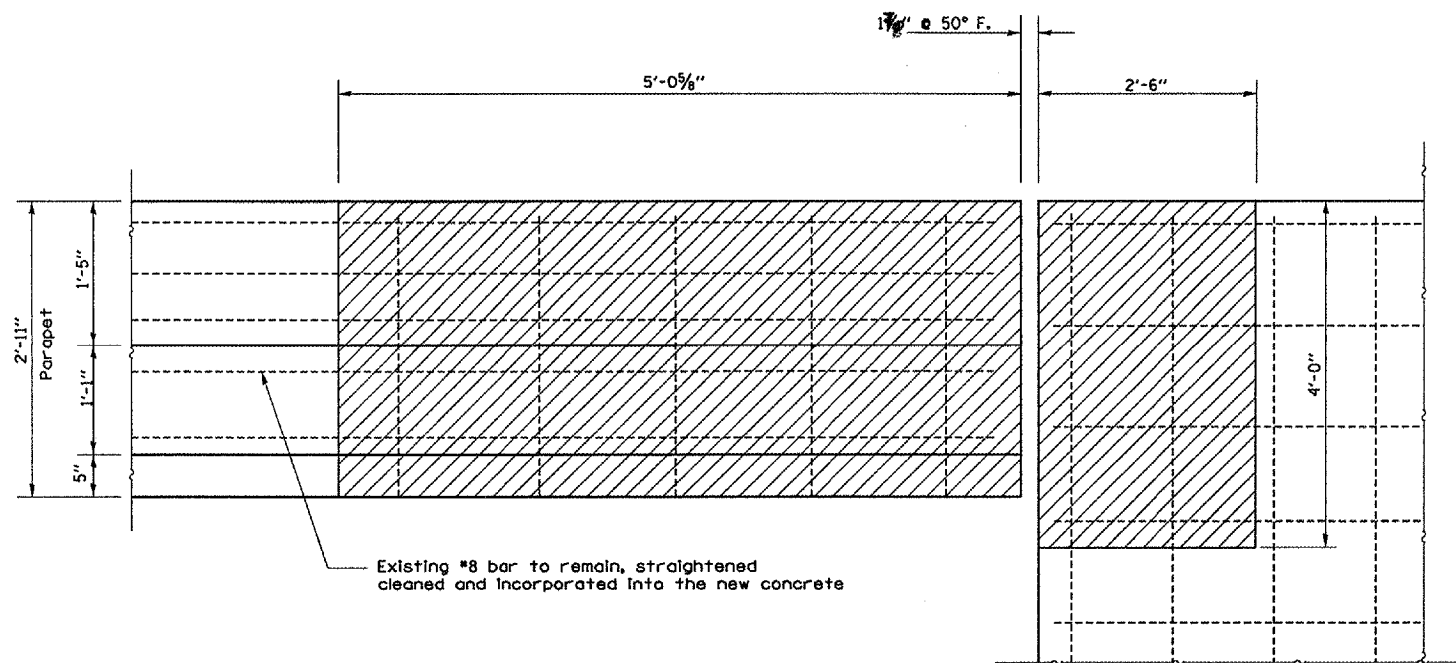

ELEVATION AT WEST PARAPET

CONCRETE REMOVAL

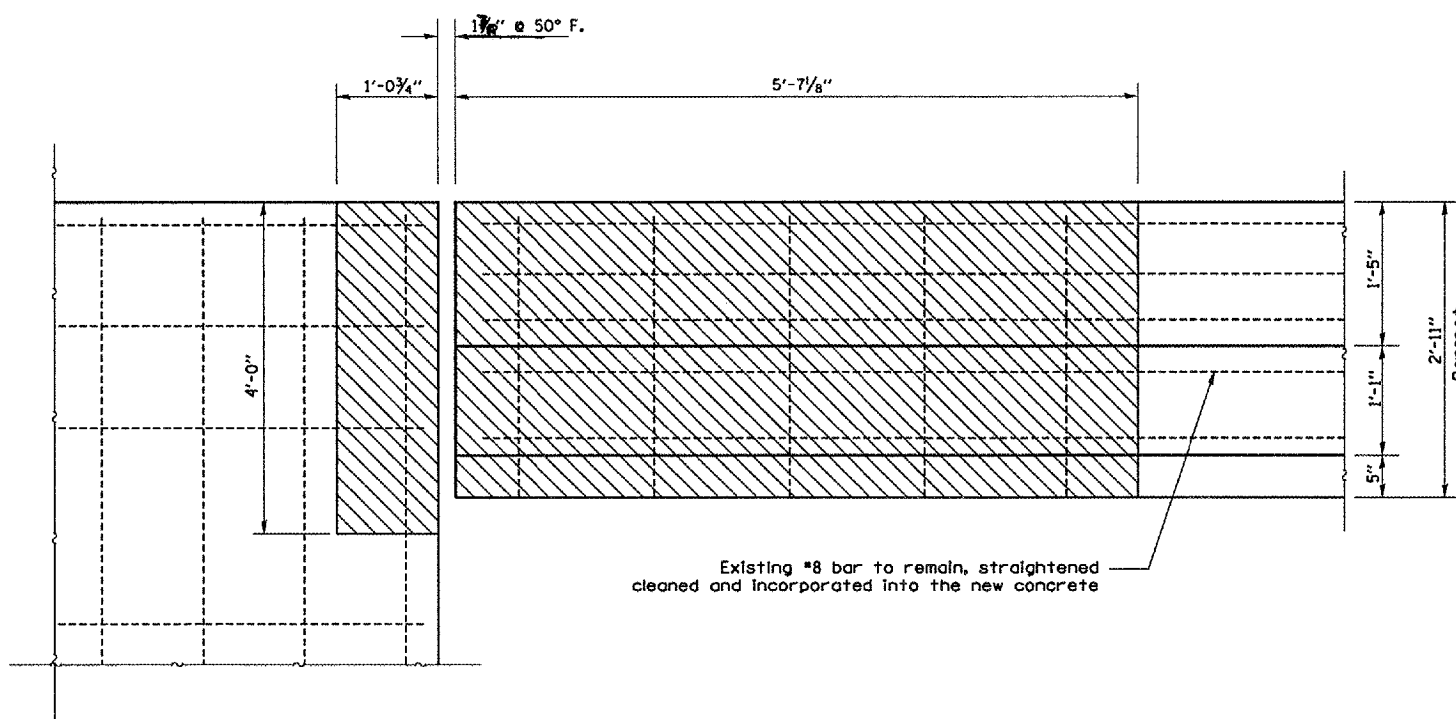

ELEVATION AT EAST PARAPET

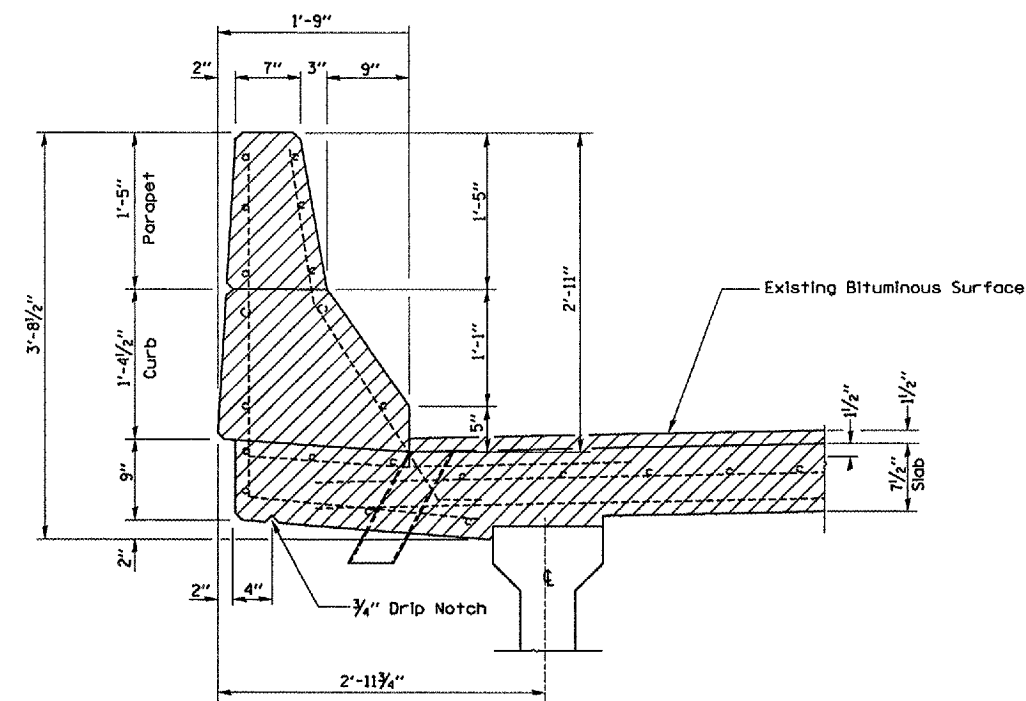

Minimum Bar Lap

- #4 1'-8"
- #5 2'-2"
- #6 2'-7"
- #7 3'-5"
- #8 4'-6"

SECTION B-B

@ Rt <'s

SHEET 2 OF 2

REVISIONS	
NAME	DATE

ILLINOIS DEPARTMENT OF TRANSPORTATION  
**CONCRETE REMOVAL-NORTH ABUT. PARAPET DETAILS**  
 S.N. 050-0174  
 F.A.I. 412 NORTHBOUND  
 OVER C. & N.W. RAILROAD  
 SECTION (50-5B)I-1  
 STA. 1216+43.45  
 DATE 04/24/2005  
 DRAWN BY RW  
 CHECKED BY

MARCH 30, 2005  
 C:\PROJECTS\CMA\06\CM303\DATA\LS.DGN

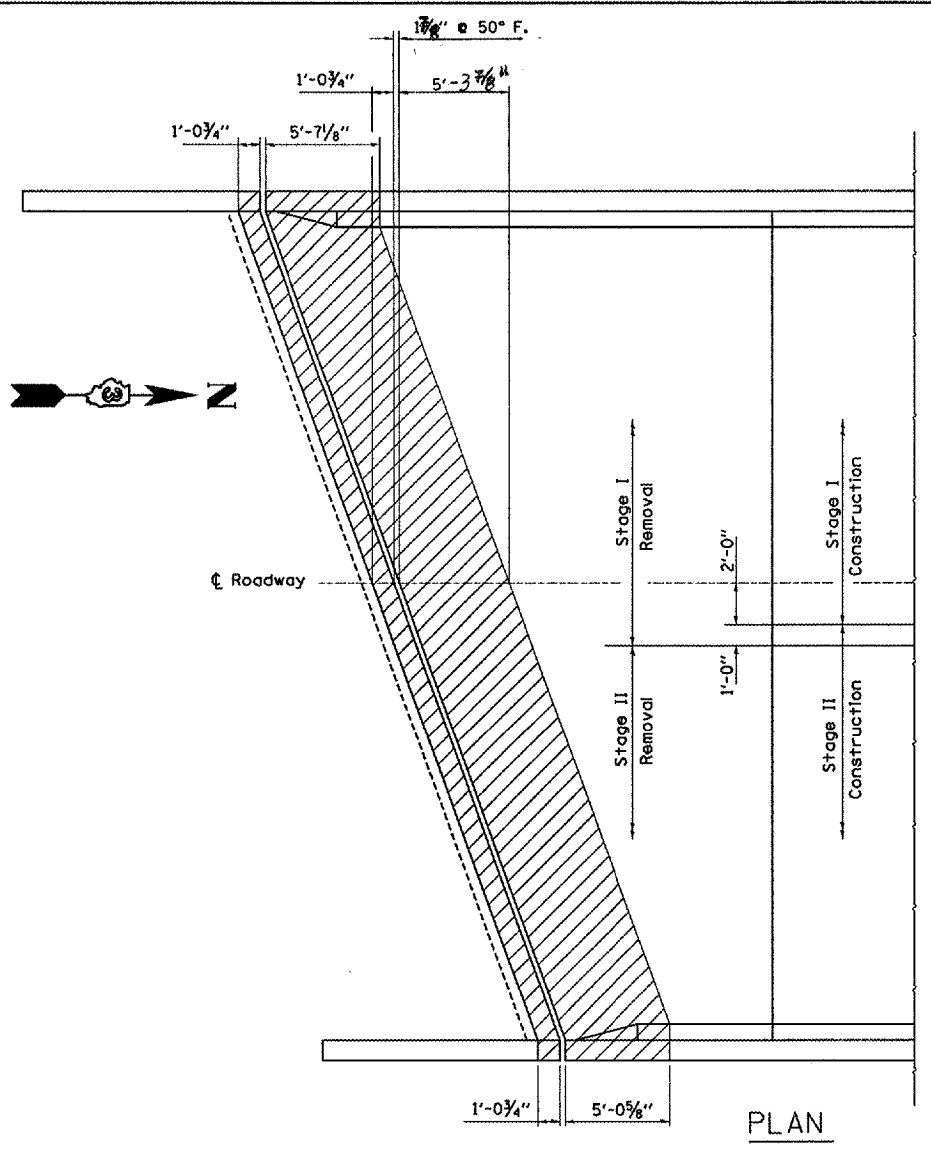

- CONCRETE REMOVAL
- BITUMINOUS REMOVAL (DECK)
- BRIDGE DECK HYDRO-SCARIFICATION

**Minimum Bar Lap**

- #4 1'-8"
- #5 2'-2"
- #6 2'-7"
- #7 3'-5"
- #8 4'-6"

Existing reinforcement shall be straightened, cleaned and incorporated into the new concrete unless shown otherwise

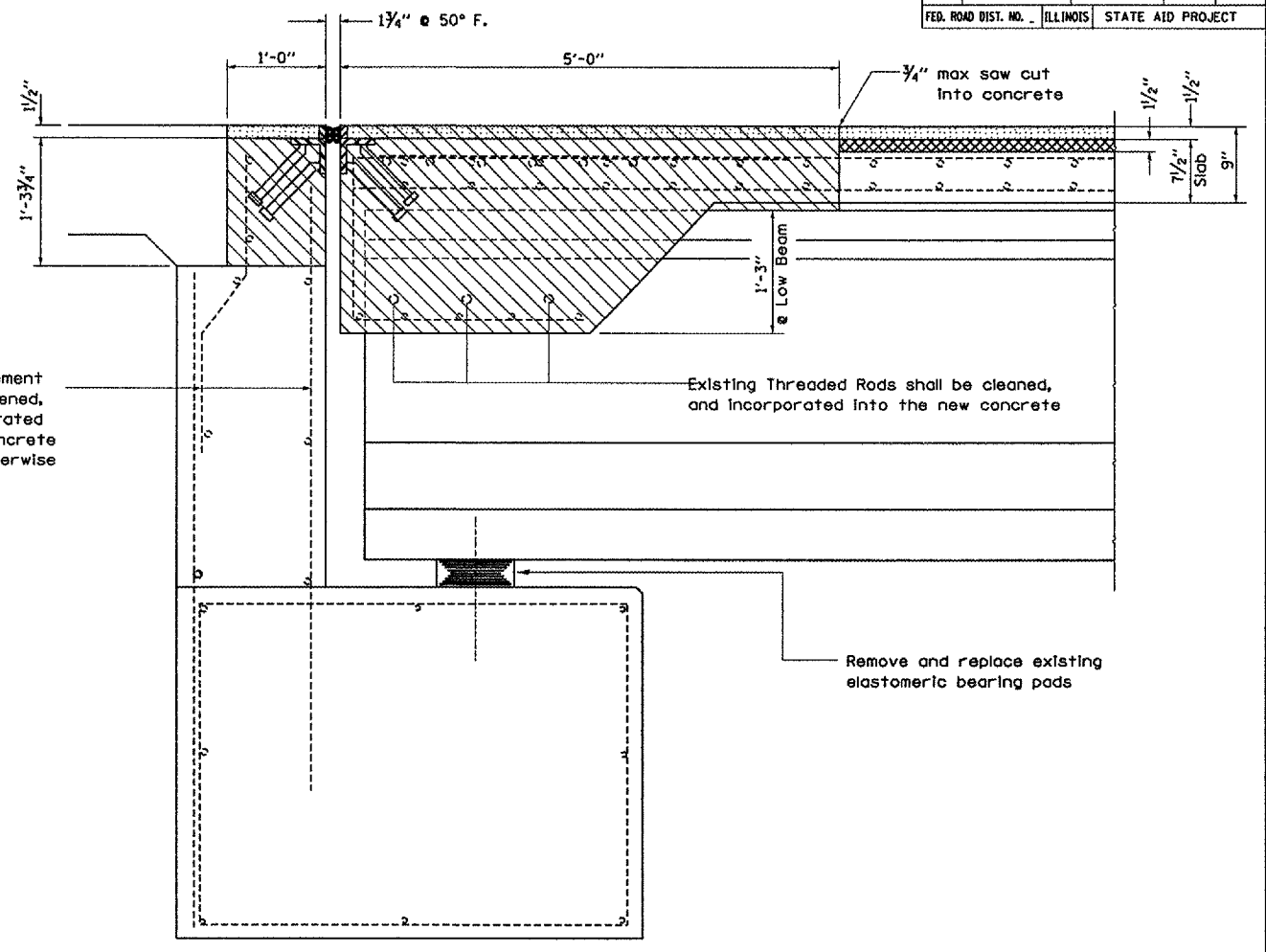

**ABUTMENT SECTION**  
@ Rt <'s

**BILL OF MATERIAL SOUTH ABUTMENT**

Item	Unit	Total
CONCRETE REMOVAL	CU. YD.	15.5
JACK AND REPLACE BEARINGS	EACH	6

REVISIONS	
NAME	DATE

ILLINOIS DEPARTMENT OF TRANSPORTATION  
**CONCRETE REMOVAL-SOUTH ABUT. DECK DETAILS**  
 S.N. 050-0174  
 F.A.I. 412 NORTHBOUND  
 OVER C & N.W. RAILROAD  
 SECTION (50-5B)I-1  
 STA. 1216 + 43.45

DATE 04/24/2005  
 DRAWN BY RW  
 CHECKED BY

MARCH 30, 2005  
 C:\PROJECTS\DMA\106\CM303\DETAILS.DGN



F.A.I. RTE.	SECTION	COUNTY	TOTAL SHEETS	SHEET NO.
412	(50-5B)I-1	LASALLE	29	9
FED. ROAD DIST. NO. ILLINOIS		STATE AID PROJECT		

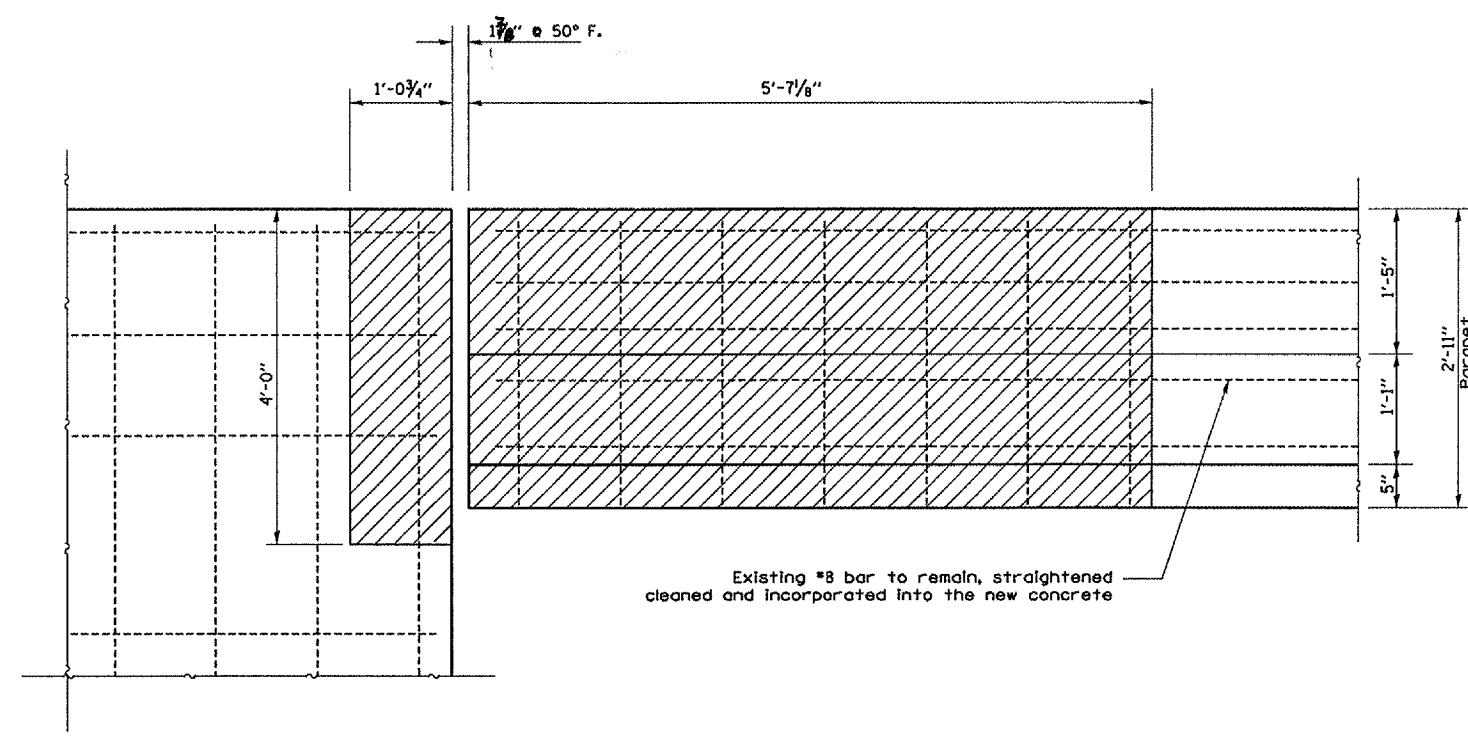

ELEVATION AT WEST PARAPET

CONCRETE REMOVAL

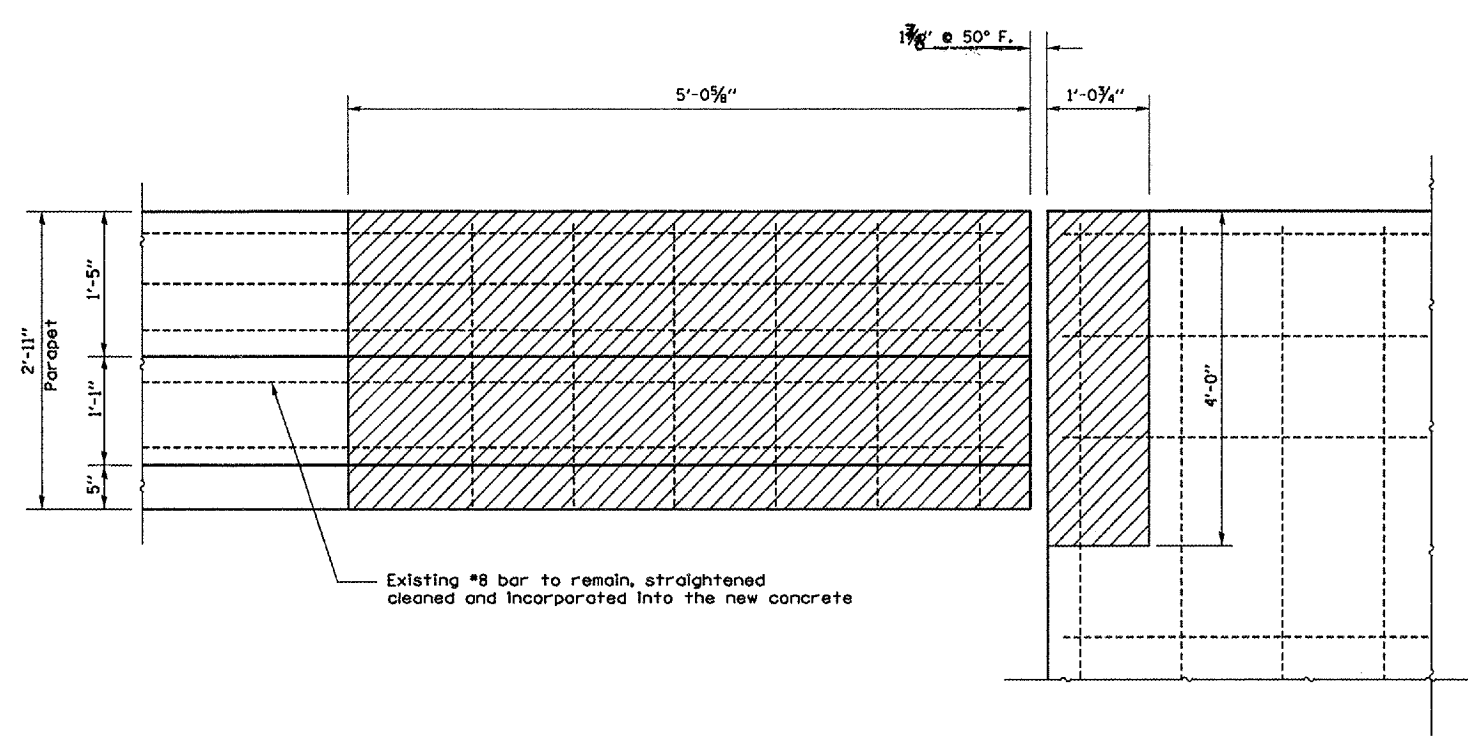

ELEVATION AT EAST PARAPET

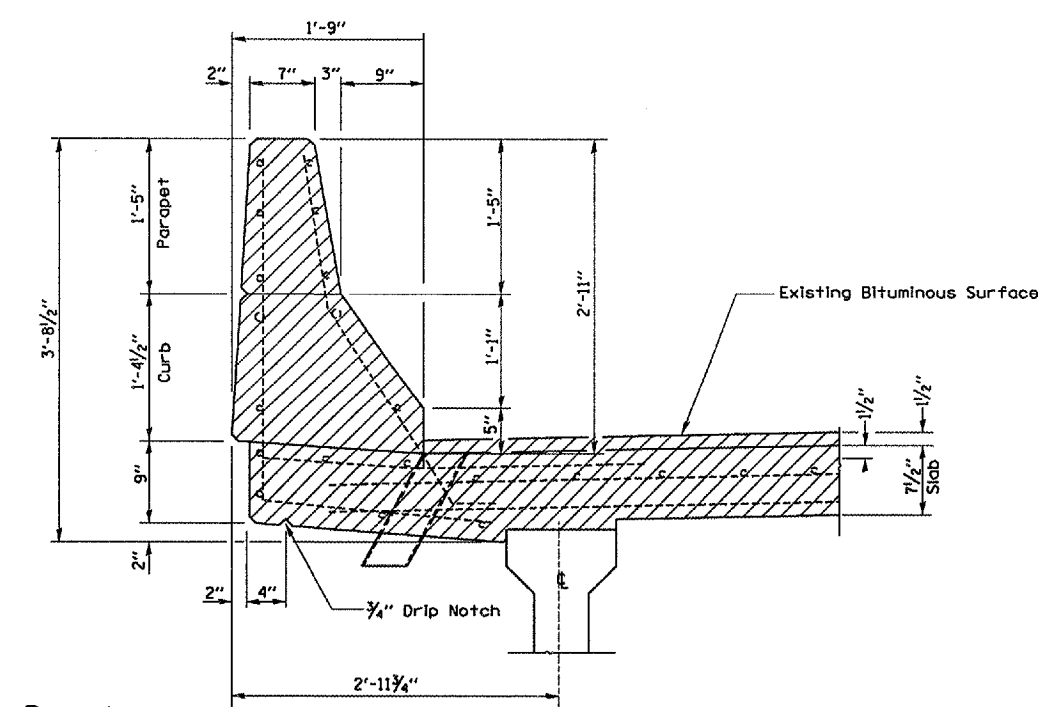

SECTION B-B  
@ Rt <'s

Minimum Bar Lap

- #4 1'-8"
- #5 2'-2"
- #6 2'-7"
- #7 3'-5"
- #8 4'-6"

REVISIONS	
NAME	DATE

ILLINOIS DEPARTMENT OF TRANSPORTATION  
**CONCRETE REMOVAL-SOUTH ABUT. PARAPET DETAILS**  
 S.N. 050-0174  
 F.A.I. 412 NORTHBOUND  
 OVER C. & N.W. RAILROAD  
 SECTION (50-5B)I-1  
 STA. 1216+43.45  
 DATE 04/24/2005  
 DRAWN BY RW  
 CHECKED BY

MARCH 30, 2005  
C:\PROJECTS\DMA\106\CM\303\DETAILS.DGN

F.A.I. RTE.	SECTION	COUNTY	TOTAL SHEETS	SHEET NO.
412	(50-5B)I-1	LASALLE	29	10
FED. ROAD DIST. NO. ILLINOIS		STATE AID PROJECT		

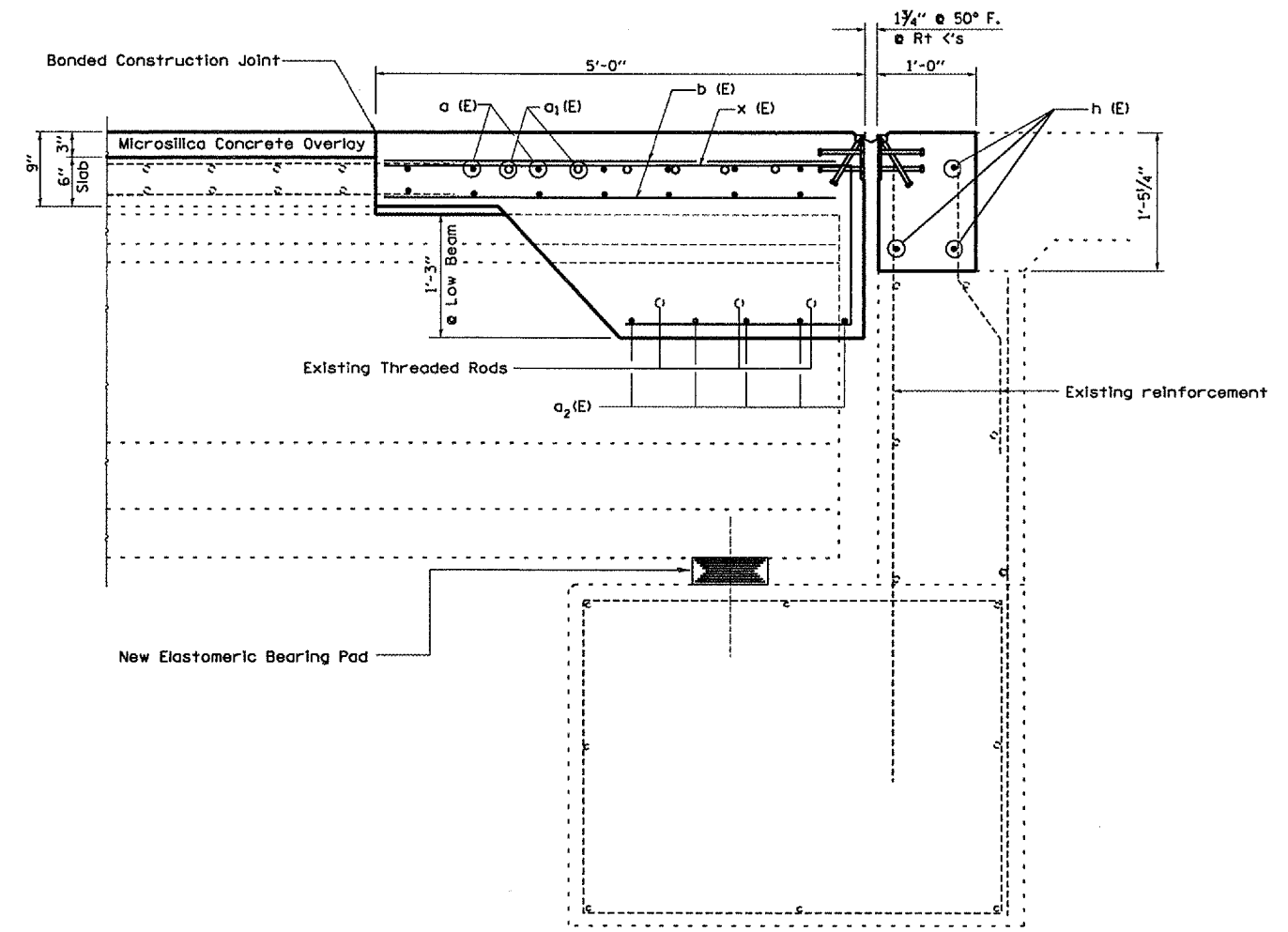
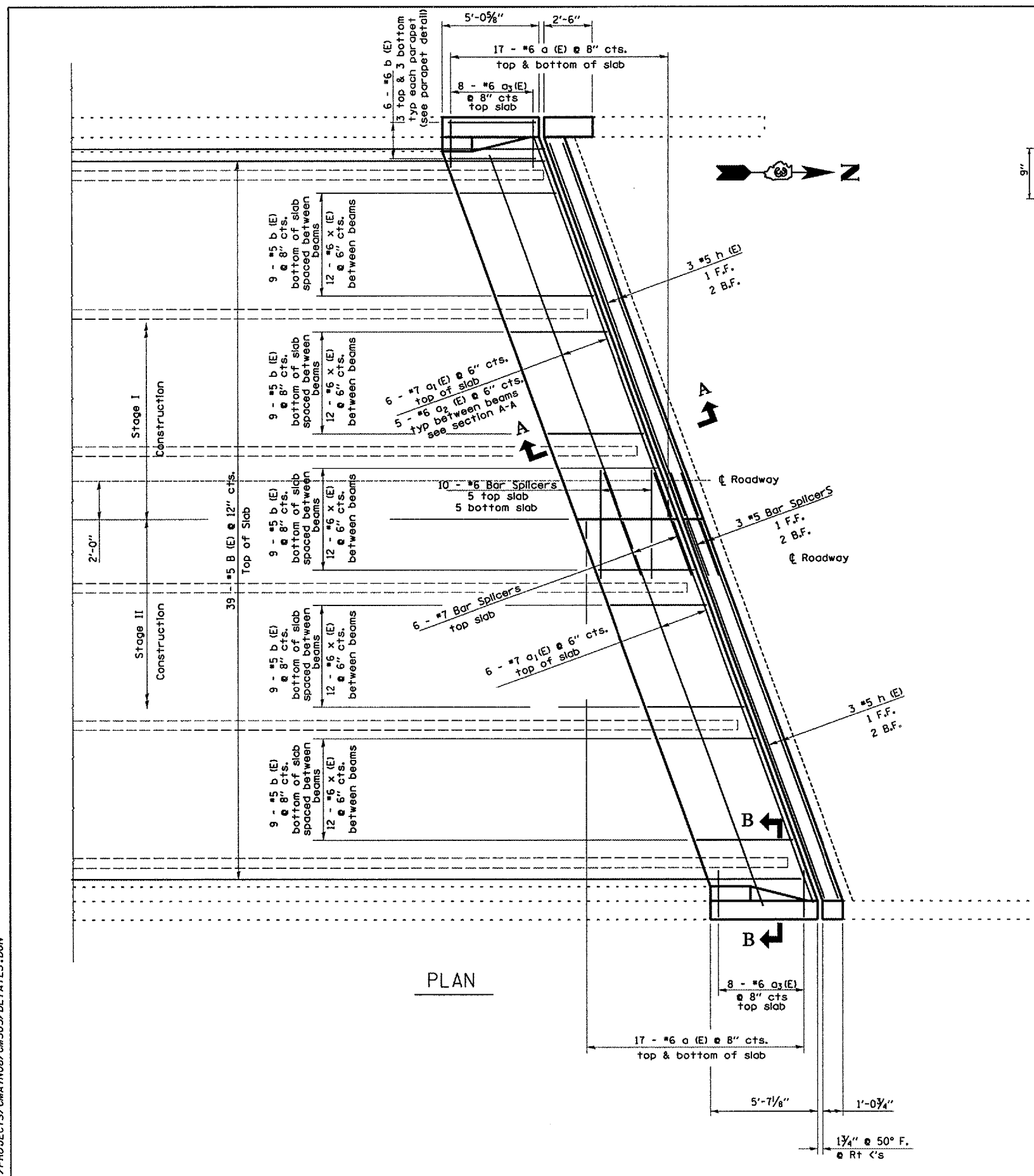

**SUPERSTRUCTURE  
BILL OF MATERIAL**

Bar	No.	Size	Length	Shape
a(E)	34	#6	13'-6"	—
a <sub>1</sub> (E)	12	#7	22'-0"	—
a <sub>2</sub> (E)	25	#6	5'-11"	—
a <sub>3</sub> (E)	16	#6	4'-0"	—
b(E)	96	#5	5'-0"	—
d(E)	12	#5	3'-0"	┌
d <sub>1</sub> (E)	12	#5	3'-1"	┌
d <sub>2</sub> (E)	12	#4	3'-0"	┌
d <sub>3</sub> (E)	12	#4	4'-9"	┌
e(E)	6	#4	4'-9"	—
e <sub>1</sub> (E)	2	#5	4'-9"	—
e <sub>2</sub> (E)	6	#4	5'-3"	—
e <sub>3</sub> (E)	2	#5	5'-3"	—
h (E)	6	#5	20'-11"	—
v (E)	8	#6	3'-8"	—
x (E)	60	#6	8'-6"	—
Reinforcement Bars, Epoxy Coated		Pound	3188	
Concrete Superstructure		Cu. Yds.	15.7	

Reinforcement bars designated (E) shall be epoxy coated.

REVISIONS	
NAME	DATE

ILLINOIS DEPARTMENT OF TRANSPORTATION  
**RECONSTRUCTION - NORTH ABUT.**  
**DECK DETAILS**  
S.N. 050-0174  
F.A.I. 412 NORTHBOUND  
OVER C. & N.W. RAILROAD  
SECTION (50-5B)I-1  
STA. 1216 + 43.45

DATE 04/24/2005

DRAWN BY RW  
CHECKED BY

MARCH 30, 2005  
C:\PROJECTS\CMA INOB\CM303\DETAILS.DGN

F.A.I. RTE.	SECTION	COUNTY	TOTAL SHEETS	SHEET NO.
412	(50-5B)I-1	LASALLE	29	11
FED. ROAD DIST. NO.		ILLINOIS	STATE AID PROJECT	

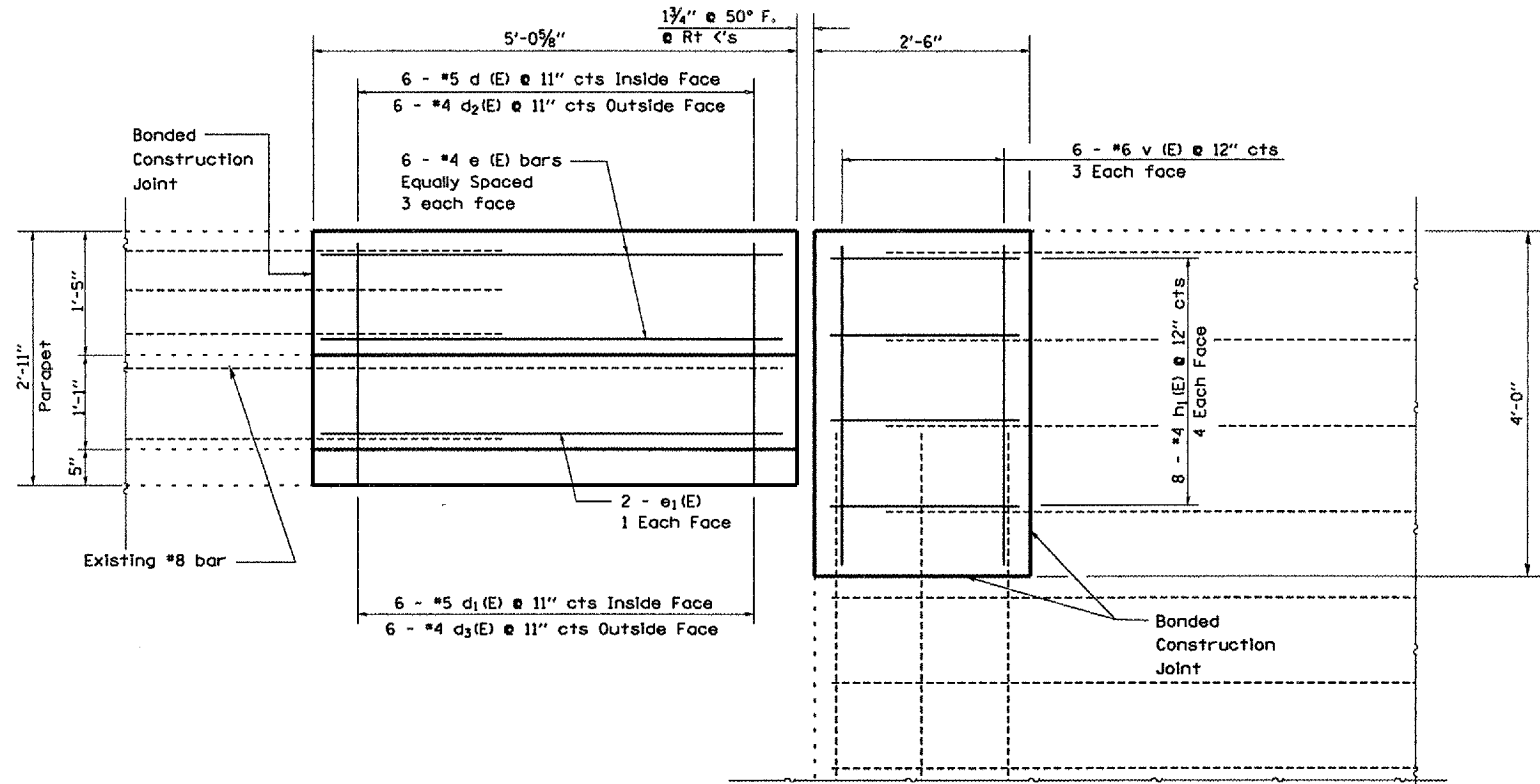

ELEVATION AT WEST PARAPET

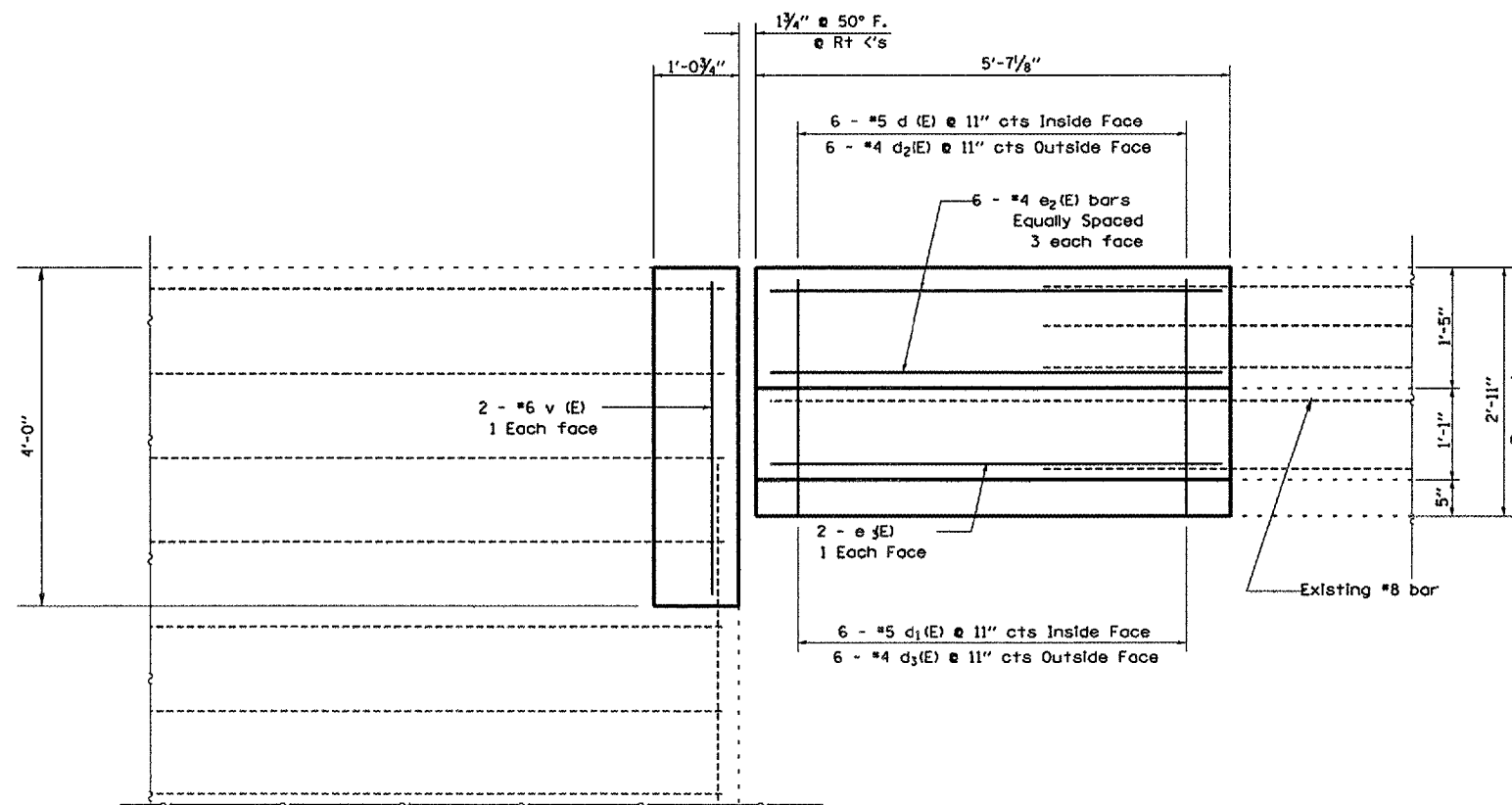

ELEVATION AT EAST PARAPET

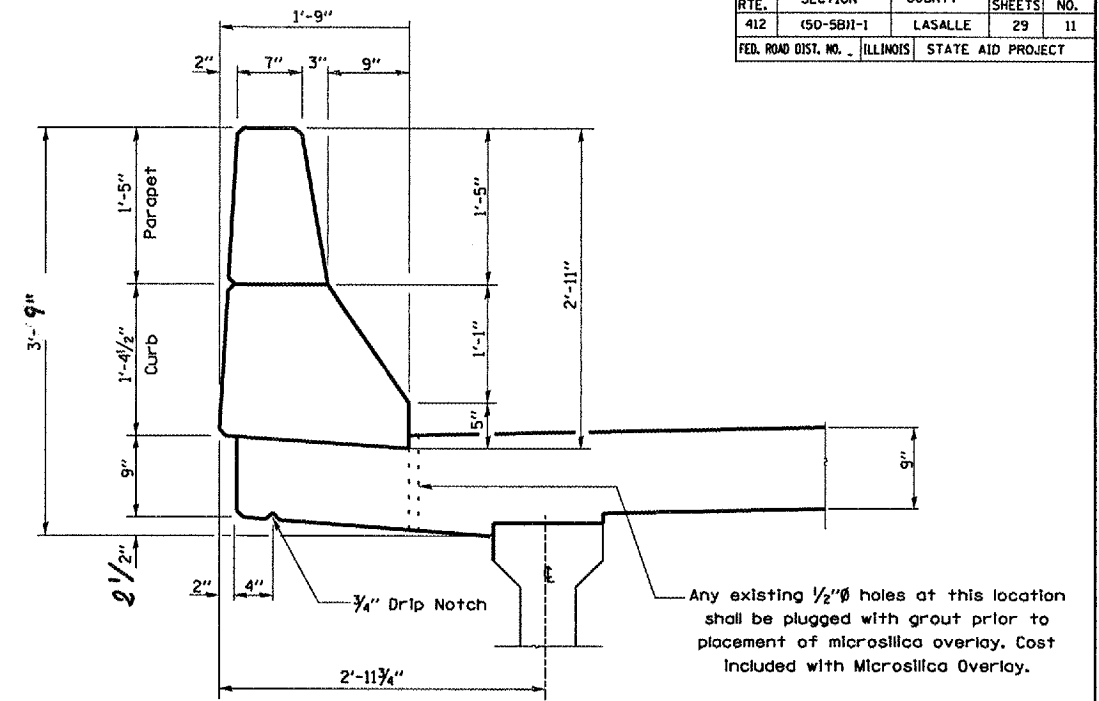

SECTION B-B  
DIMENSIONS

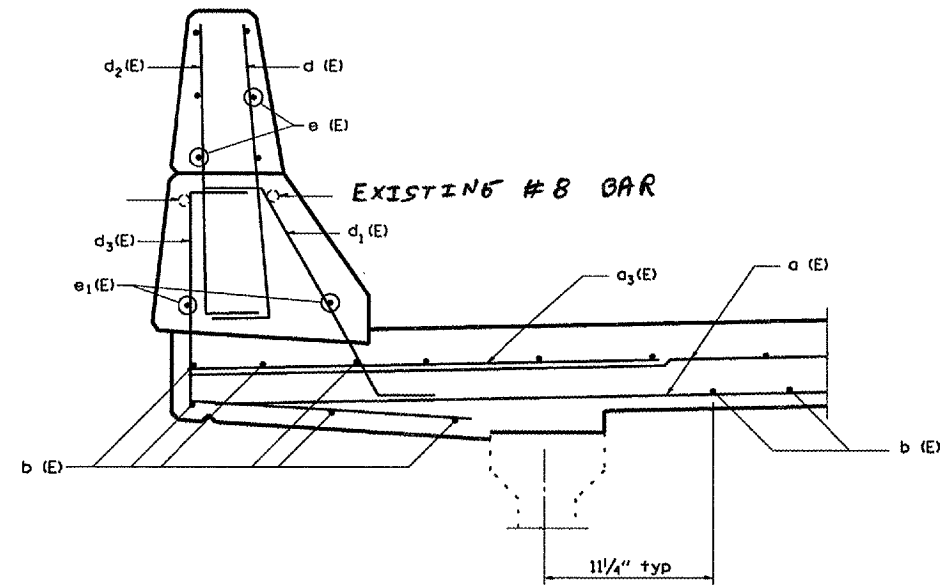

SECTION B-B  
REINFORCEMENT

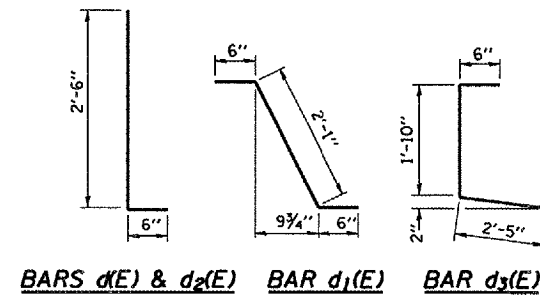

REVISIONS	
NAME	DATE

ILLINOIS DEPARTMENT OF TRANSPORTATION  
**RECONSTRUCTION - NORTH ABUT.**  
**PARAPET DETAILS**  
 S.N. 050-0174  
 F.A.I. 412 NORTHBOUND  
 OVER C. & N.W. RAILROAD  
 SECTION (50-5B)I-1  
 STA. 1216 + 43.45  
 DATE 04/24/2005  
 DRAWN BY RW  
 CHECKED BY

MARCH 30, 2005  
 C:\PROJECTS\CM\1106\CM303\DETAILS.DGN

F.A.I. RTE.	SECTION	COUNTY	TOTAL SHEETS	SHEET NO.
412	(50-5B)I-1	LASALLE	29	12
FED. ROAD DIST. NO.		ILLINOIS STATE AID PROJECT		

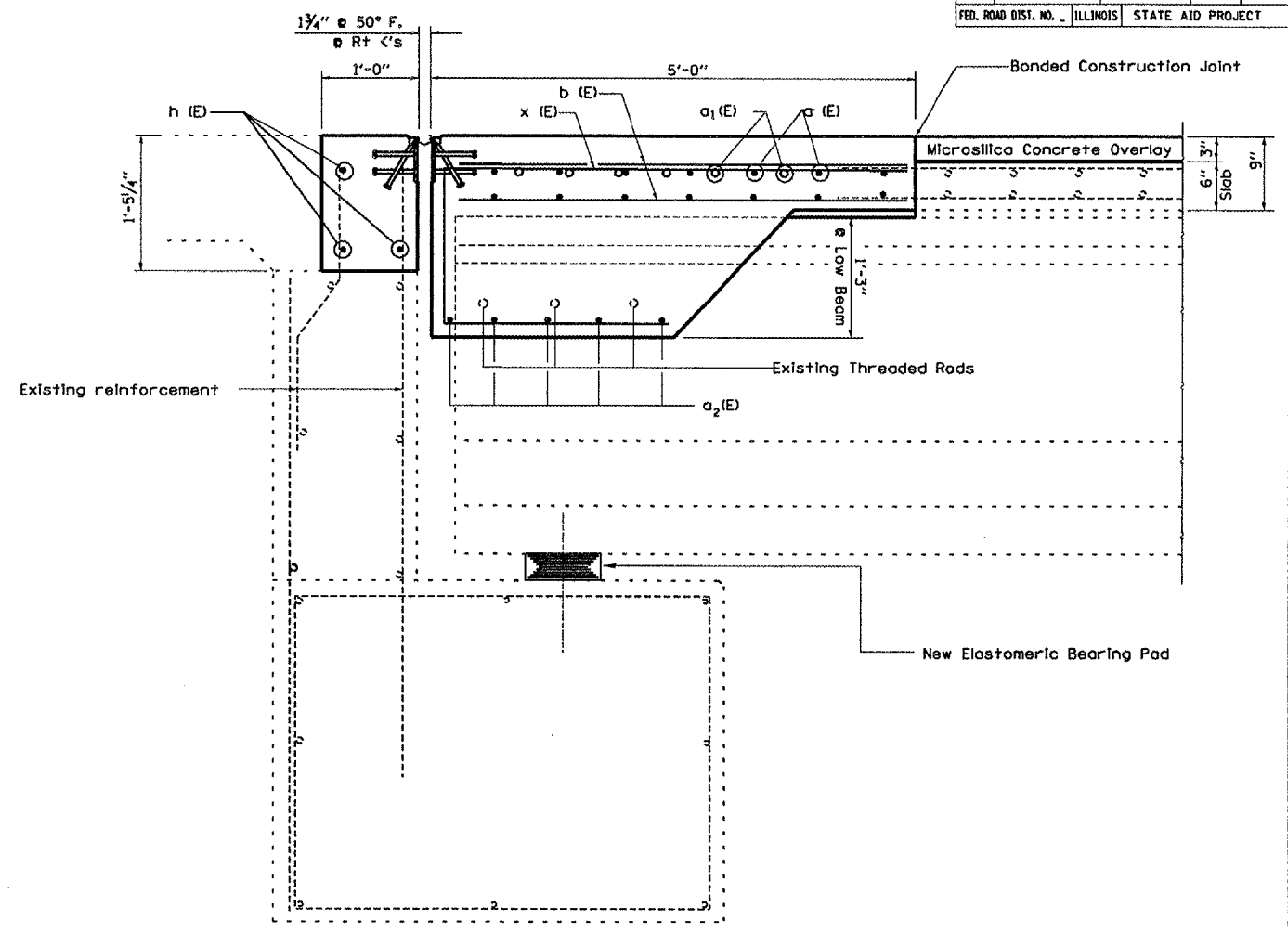
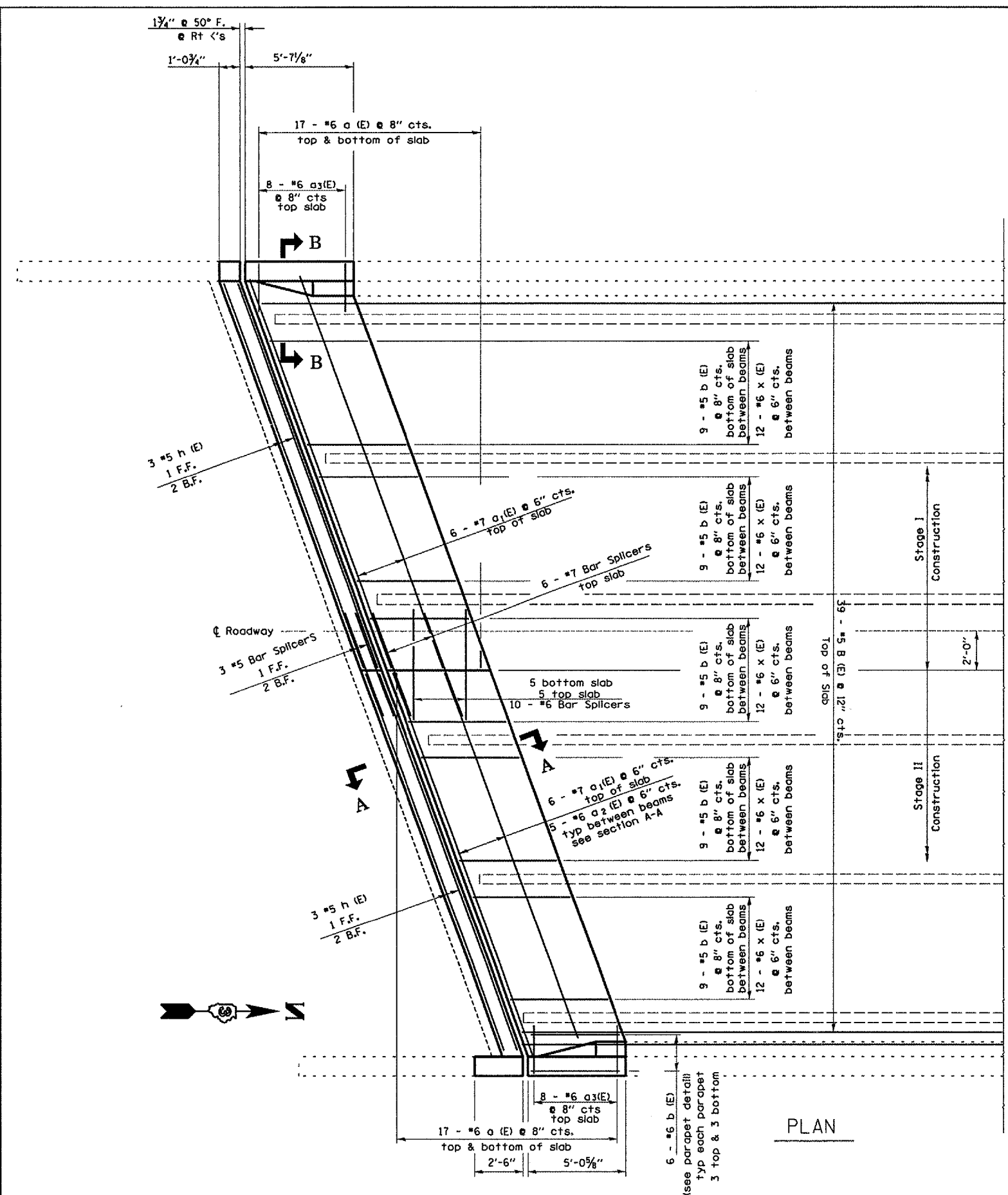

**SUPERSTRUCTURE  
BILL OF MATERIAL**

Bar	No.	Size	Length	Shape
a(E)	34	#6	13'-6"	—
a <sub>1</sub> (E)	12	#7	22'-0"	—
a <sub>2</sub> (E)	25	#6	5'-11"	—
a <sub>3</sub> (E)	16	#6	4'-0"	—
b(E)	96	#5	5'-0"	—
d(E)	12	#5	3'-0"	—
d <sub>1</sub> (E)	12	#5	3'-1"	—
d <sub>2</sub> (E)	12	#4	3'-0"	—
d <sub>3</sub> (E)	12	#4	4'-9"	—
e(E)	6	#4	4'-9"	—
e <sub>1</sub> (E)	2	#5	4'-9"	—
e <sub>2</sub> (E)	6	#4	5'-3"	—
e <sub>3</sub> (E)	2	#5	5'-3"	—
h(E)	6	#5	20'-11"	—
v(E)	4	#6	3'-8"	—
x(E)	60	#6	8'-6"	—
Reinforcement Bars, Epoxy Coated		Pound	3166	
Concrete Superstructure		Cu. Yds.	15.5	

Reinforcement bars designated (E) shall be epoxy coated.

**SECTION A-A  
@ Rt <'s**

REVISIONS	DATE
NAME	DATE

ILLINOIS DEPARTMENT OF TRANSPORTATION  
**RECONSTRUCTION - SOUTH ABUT.  
DECK DETAILS**  
S.N. 050-0174  
F.A.I. 412 NORTHBOUND  
OVER C. & N.W. RAILROAD  
SECTION (50-5B)I-1  
STA. 1216 + 43.45  
DATE 04/24/2005  
DRAWN BY RW  
CHECKED BY

MARCH 30, 2005  
C:\PROJECTS\CMA IN06\CM303\DETAILS.DGN

F.A.I. RTE.	SECTION	COUNTY	TOTAL SHEETS	SHEET NO.
412	(50-5B)I-1	LASALLE	29	13
FED. ROAD DIST. NO. ILLINOIS		STATE AID PROJECT		

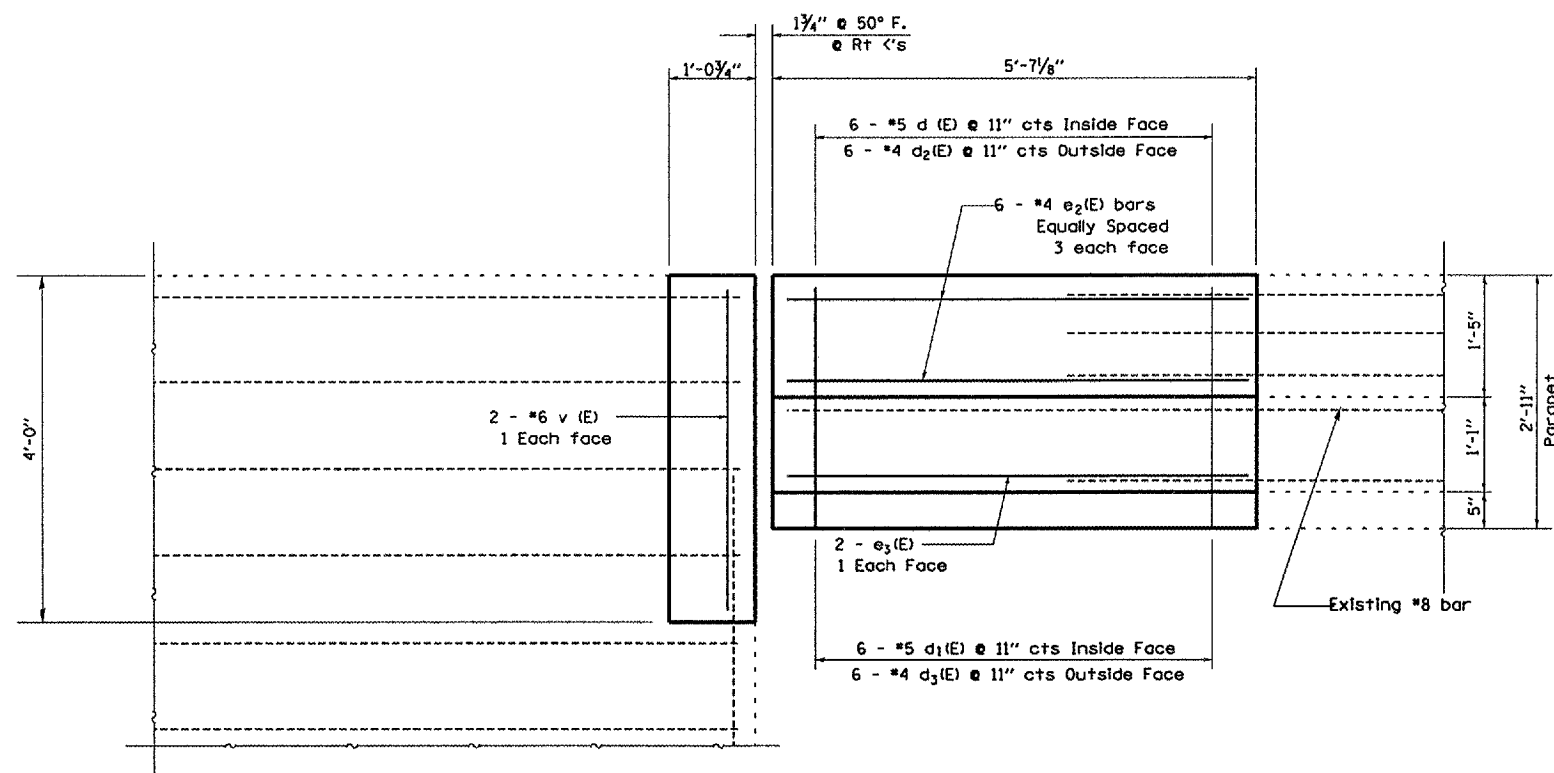

ELEVATION AT WEST PARAPET

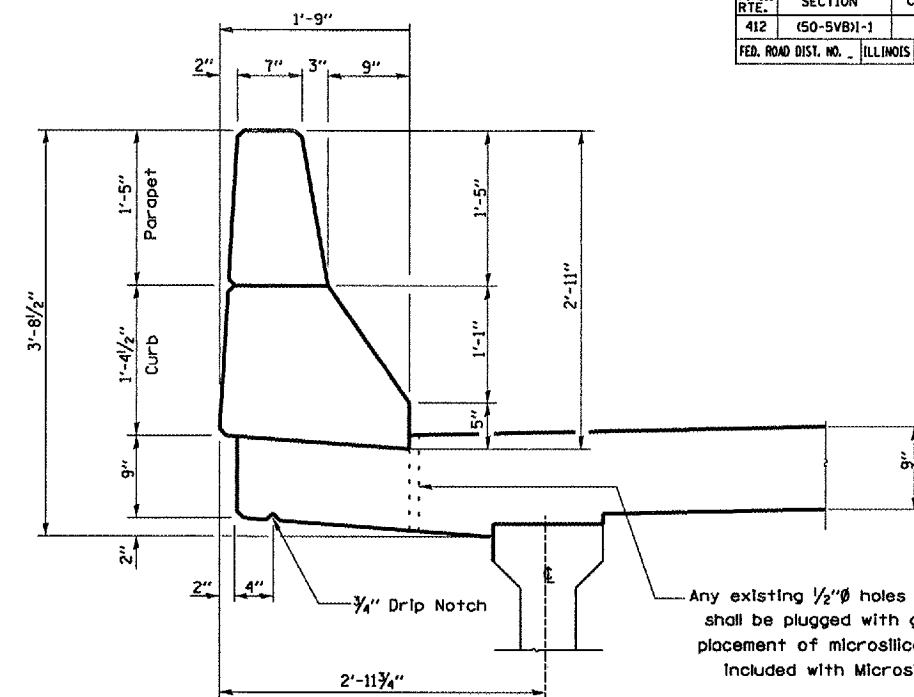

SECTION B-B  
DIMENSIONS

Any existing 1/2" Ø holes at this location shall be plugged with grout prior to placement of microsilica overlay. Cost included with Microsilica Overlay.

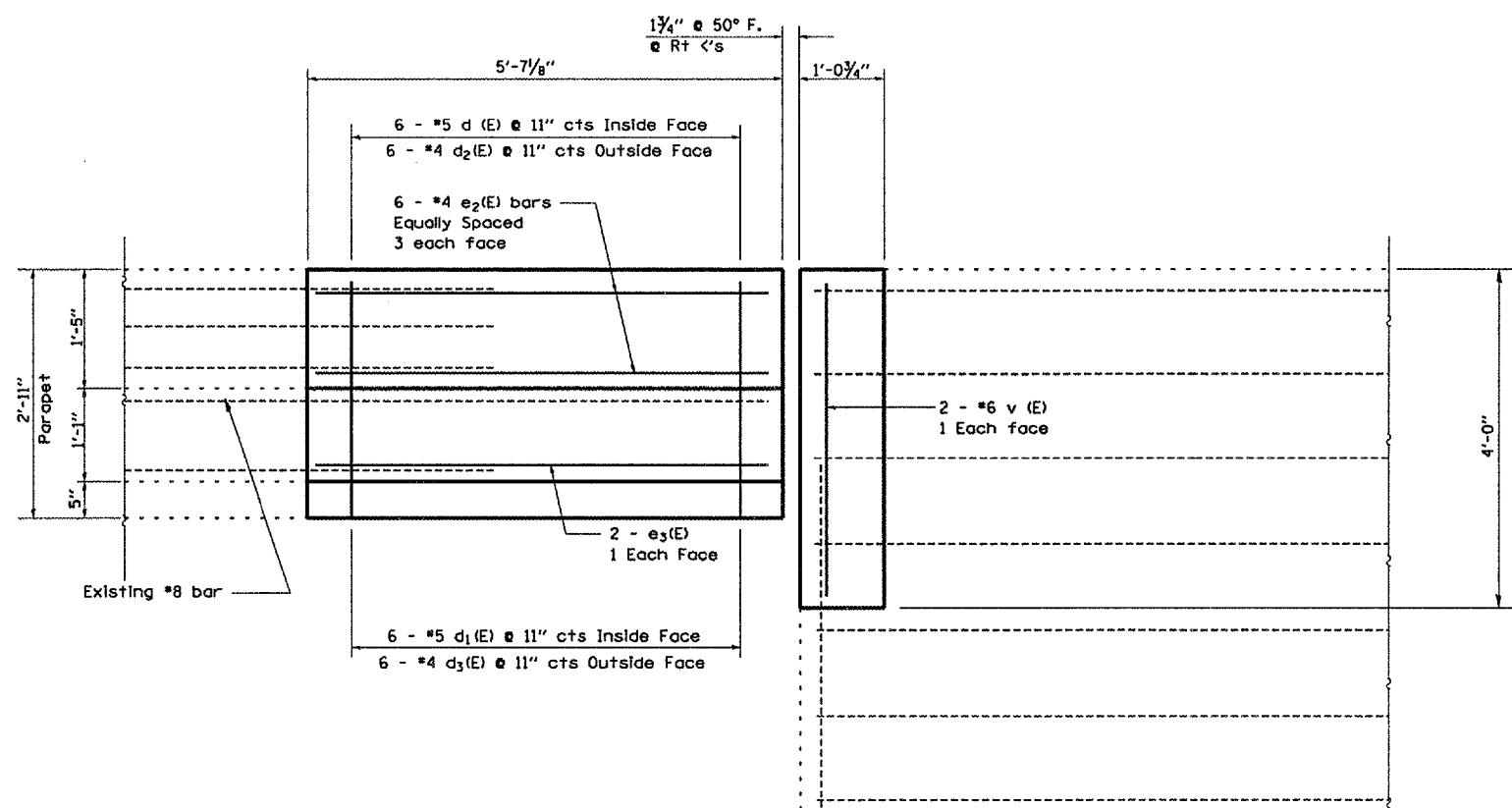

ELEVATION AT EAST PARAPET

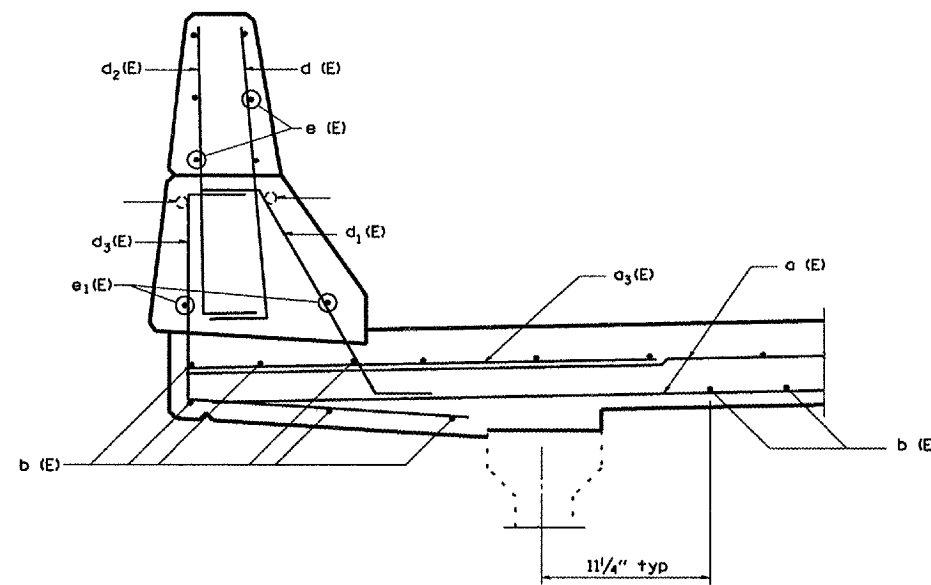

SECTION B-B  
REINFORCEMENT

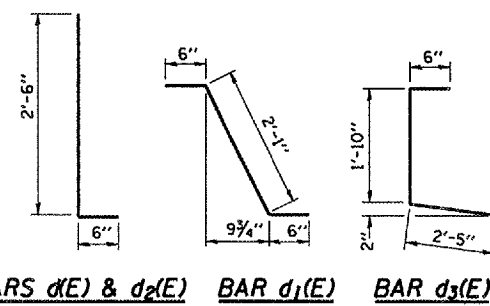

BARS d(E) & d<sub>2</sub>(E) BAR d<sub>1</sub>(E) BAR d<sub>3</sub>(E)

REVISIONS	
NAME	DATE

ILLINOIS DEPARTMENT OF TRANSPORTATION  
**RECONSTRUCTION - SOUTH ABUT.**  
**PARAPET DETAILS**  
 S.N. 050-0174  
 F.A.I. 412 NORTHBOUND  
 OVER C. & N.W. RAILROAD  
 SECTION (50-5B)I-1  
 STA. 1216 + 43.45  
 DATE 04/24/2005  
 DRAWN BY RW  
 CHECKED BY

MARCH 30, 2005  
C:\PROJECTS\CMA IN06\CM303\DETAILS.DGN

F.A.I. RTE.	SECTION	COUNTY	TOTAL SHEETS	SHEET NO.
412	(50-5B)I-1	LASALLE	29	14
FED. ROAD DIST. NO.		ILLINOIS STATE AID PROJECT		

\* Granular or solid flux filled headed studs conforming to Article 1006.32 of the Std. Specs., automatically end welded.

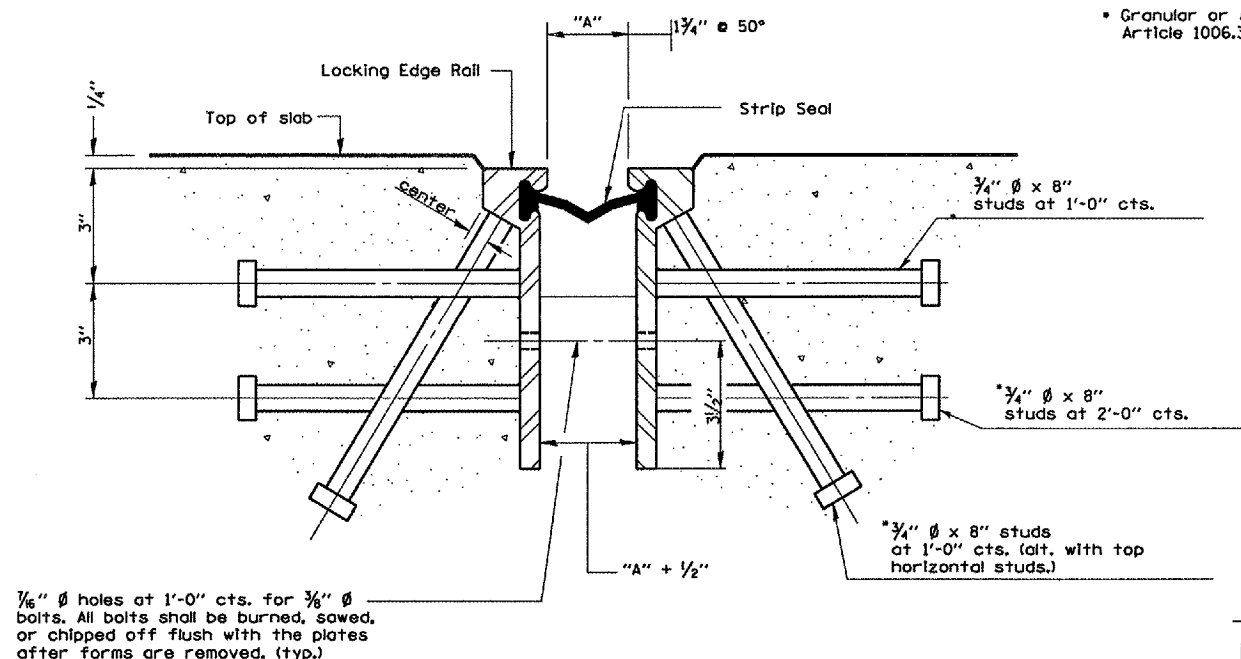

SECTION THRU ROLLED RAIL EXP. JOINT  
( 424 Studs Required)

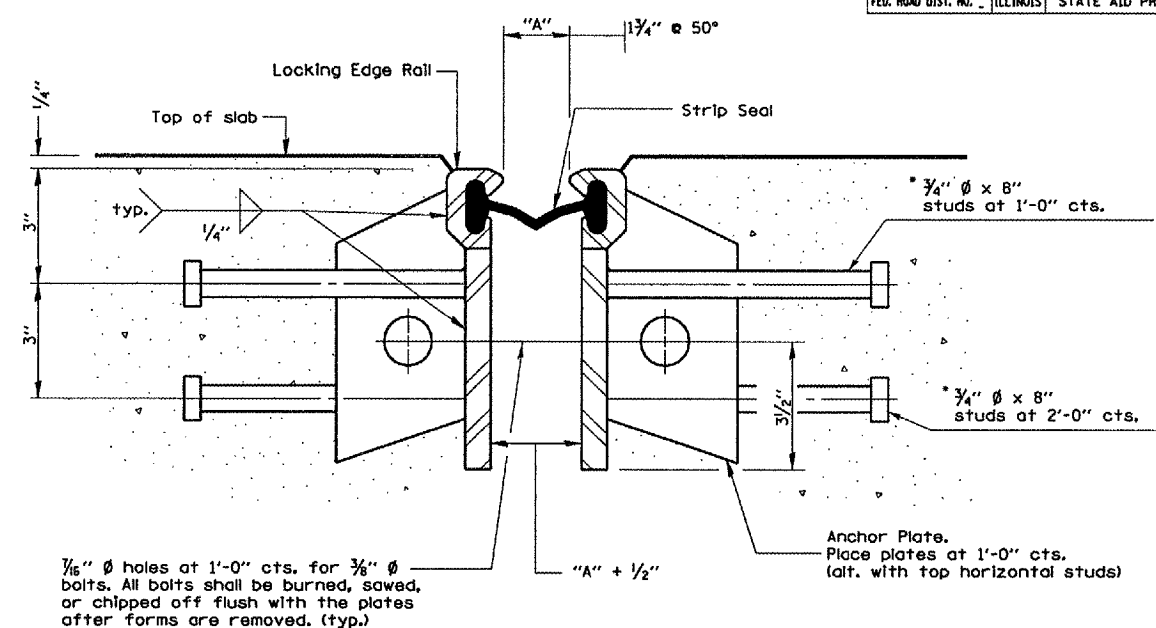

SECTION THRU WELDED RAIL EXP. JOINT  
( 256 Studs Required)  
( 172 Anchor Plates Required)

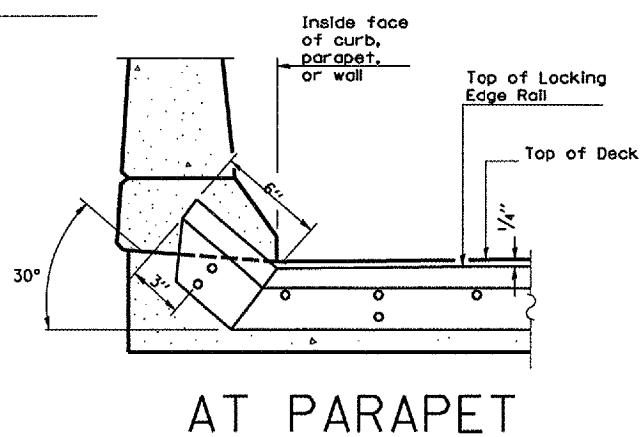

AT PARAPET

GENERAL NOTES

The strip seal shall be made continuous and shall have a minimum thickness of 1/4". The configuration of the strip seal shall match the configuration of the Locking Edge Rails.  
 The height and thickness of the Locking Edge Rails shown are minimum dimensions. The actual configuration of the Locking Edge Rails and matching strip seal may vary from manufacturer to manufacturer. Flanged edge rails will not be allowed.  
 Locking Edge Rails may be spliced at slope discontinuities and stage construction joints.  
 The manufacturer's recommended installation methods shall be followed.  
 The joint opening and deck dimensions detailed on the superstructure are based on a preformed joint seal. If the contractor elects to use the alternate strip seal joint, the opening and deck dimensions shall be modified according to the dimensions detailed on this sheet. Required modifications shall be made at no additional cost to the State.

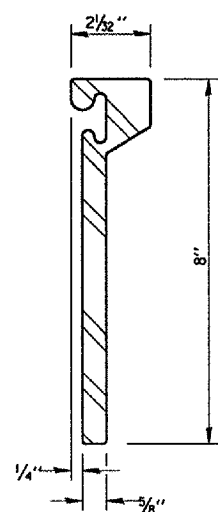

ROLLED (EXTRUDED) RAIL  
LOCKING EDGE RAILS

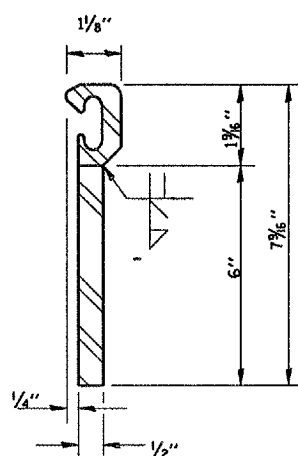

WELDED RAIL

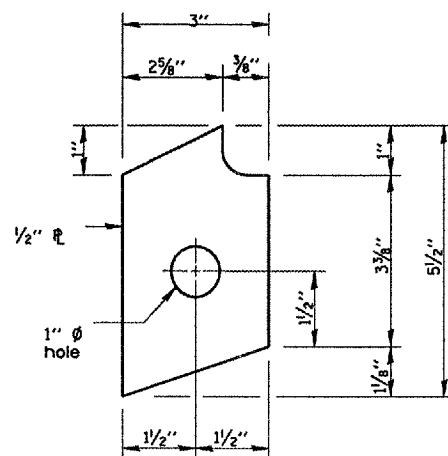

ANCHOR  
(for welded rail)

REVISIONS	
NAME	DATE

ILLINOIS DEPARTMENT OF TRANSPORTATION  
**STRIP SEAL EXPANSION  
 JOINT DETAILS**  
 S.N. 050-0174  
 F.A.I. 412 NORTHBOUND  
 OVER C. & N.W. RAILROAD  
 SECTION (50-5B)I-1  
 STA. 1216 + 43.45

DATE 04/24/2005

DRAWN BY RW  
 CHECKED BY

F.A.I. RTE.	SECTION	COUNTY	TOTAL SHEETS	SHEET NO.
412	(50-5B)I-1	LASALLE	29	15
FED. ROAD DIST. NO.	ILLINOIS	STATE AID PROJECT		

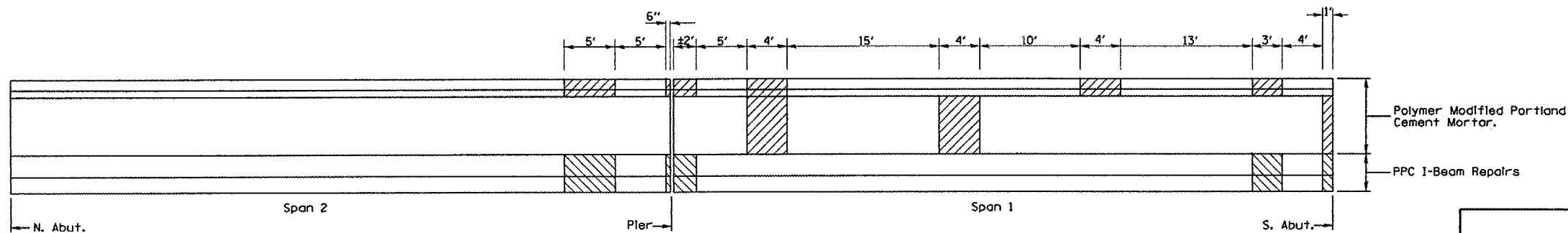

ELEVATION

WEST FASCIA BEAM  
EXTERIOR FACE  
LOOKING EAST

 POLYMER MODIFIED PORTLAND CEMENT MORTAR  
 PPC I-BEAM REPAIR

**BILL OF MATERIAL**

Item	Unit	Total
PPC I-Beam Repairs	L.S.	1
Polymer Modified Portland Cement Mortar	Sq. Ft.	29

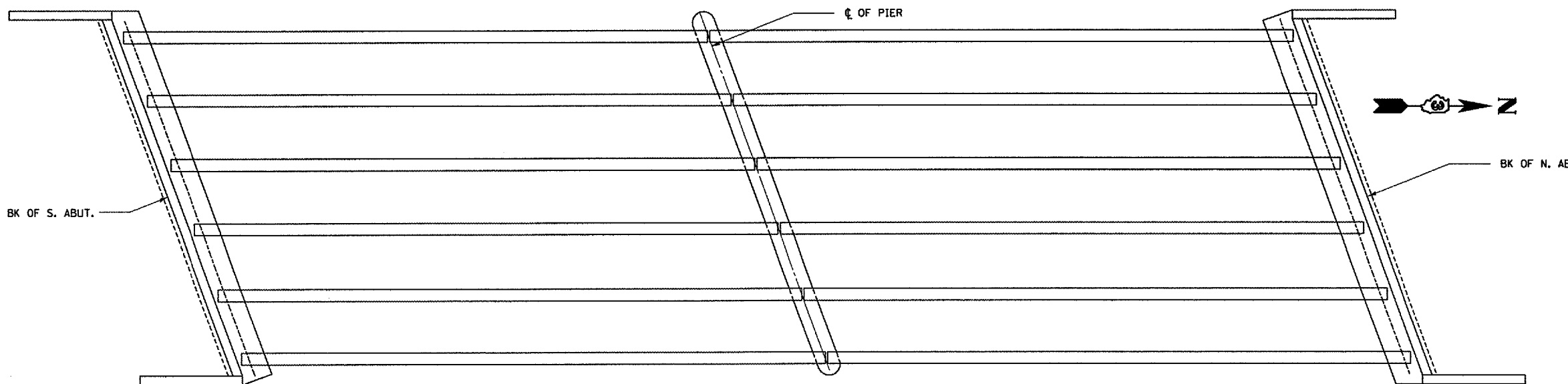

ELEVATION

EAST FASCIA BEAM  
EXTERIOR FACE  
LOOKING WEST

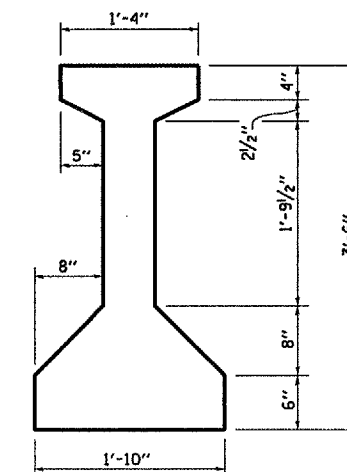

42" PPC BEAM

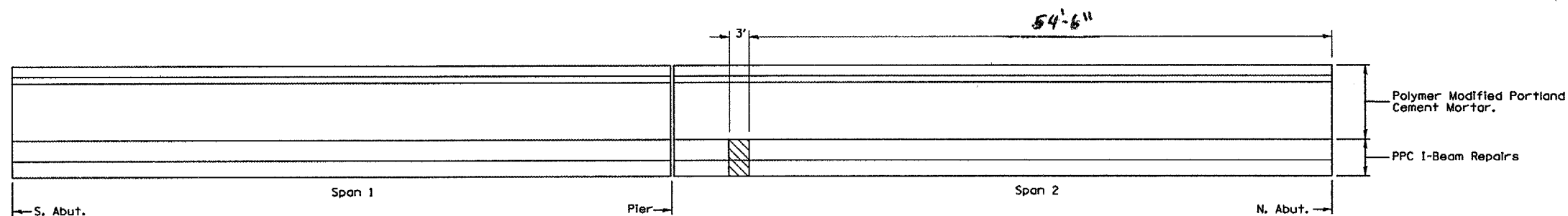

REVISIONS	
NAME	DATE

ILLINOIS DEPARTMENT OF TRANSPORTATION  
**PPC DECK BEAM REPAIR**  
S.N. 050-0174  
F.A.I. 412 NORTHBOUND  
OVER C. & N.W. RAILROAD  
SECTION (50-5B)I-1  
STA. 1216+43.45

DATE 04/24/2005

DRAWN BY RW  
CHECKED BY

MARCH 30, 2005  
C:\PROJECTS\CMA IN06\CM303\DETAILS.DGN

F.A.I. RTE.	SECTION	COUNTY	TOTAL SHEETS	SHEET NO.
412	(50-5B)	LASALLE	25	16
FED. ROAD DIST. NO. -		ILLINOIS	NON-FED. AID PROJECT	

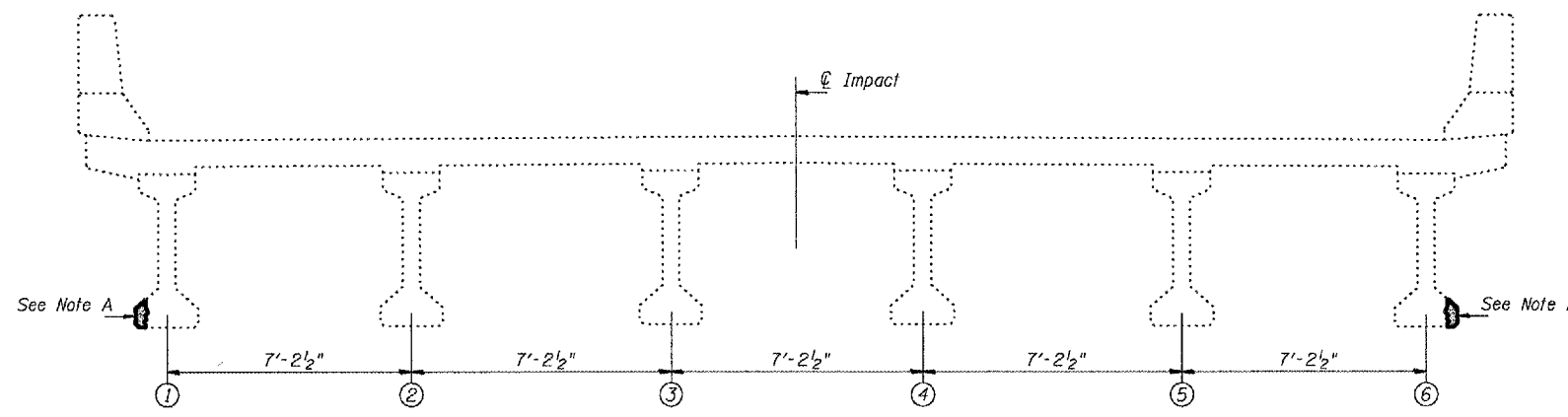

**CROSS SECTION**  
(Looking North)

Note A:  
PPC I-Beams to be repaired as detailed.

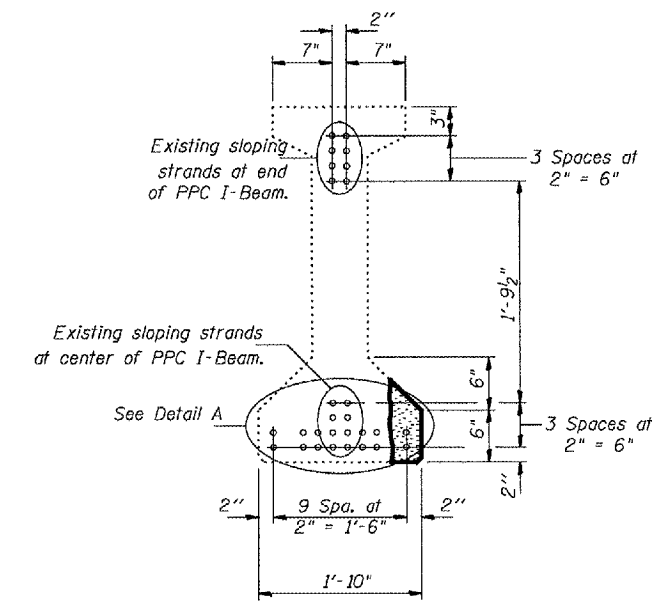

**PATCHING DETAIL**  
Beam 5, Span 3.

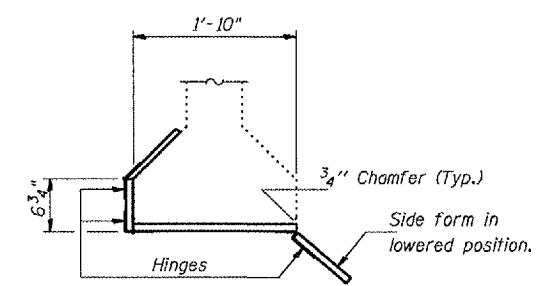

**SUGGESTED FORM DETAIL**

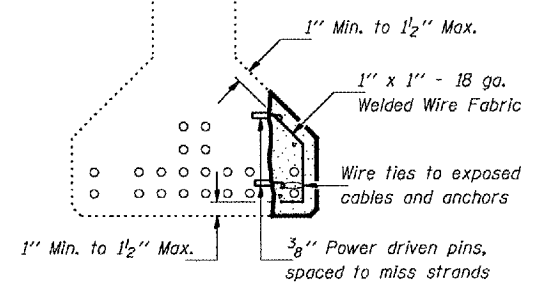

**DETAIL A**

**REPAIR PROCEDURES FOR WEST AND EAST FASCIA BEAMS**

1. The damaged area of the beam shall be cleaned of all loose and spalled concrete, and sealant. Hand tools shall be used for the removal of concrete adjacent to the prestressing strands. While a 15 pound chipping hammer may be used away from prestressing strands, extreme care shall be taken not to damage the exposed prestressing strands. Any exposed portions of the strands shall be sandblasted.
2. Using the same tools, remove the existing concrete to sound concrete along the edges of the damaged area to a depth of 1" min. to 1 1/2" max. The edges shall be saw cut 3/4" deep or less.
3. Power driven pins as shown in Detail A shall be placed at 9" alternate centers horizontally and located vertically 3" and 7" up from bottom of Fascia Beams. Use wire ties in areas where the strands are exposed as shown in Detail A. Place 1" x 1" x 18 gauge welded wire fabric in repair areas and attach it to the pins or strands with wire ties. The clearance between the finished surface of the new concrete and the welded wire fabric shall be 1" minimum. All beams involved in this work shall be rebuilt to their original dimensions.
4. All surfaces of existing concrete in the area to be repaired shall be coated with an epoxy-resin primer bonding agent. The concrete beam to be repaired or crack sealed must be at a temperature of at least 50° F. or higher.
5. The repair shall be made using a concrete meeting all the requirements specified in Section 1020 of the Standard Specifications for Class PS Concrete for precast prestressed concrete members, except the maximum size of the aggregate shall be 1/2". Place the lower form on the bottom of the beam and compact by vibrating (or other approved methods) the concrete mix into the voids. After accessible voids have been filled and compacted, the top vertical form shall be raised into position and the remaining voids filled and compacted. The sloping upper surface shall be finished to the configuration of the existing PPC I-Beam flange. The cost of concrete removal, Class PS Concrete, power driven pins, wire ties, wire mesh, epoxy bonding agent, and all other work required to perform any repairs on East and West Fascia beams is included in the Lump Sum price for PPC I-Beam Repairs.

**BILL OF MATERIAL**

ITEM	UNIT	QUANTITY
PPC I Beam Repairs	L.S.	1

REVISIONS	
NAME	DATE

ILLINOIS DEPARTMENT OF TRANSPORTATION  
**PPC I-BEAMS REPAIR**  
S.N. 050-0174 (NB)  
F.A.I. 412 OVER C. & N.W. RAILROAD  
SECTION (50-5B)I  
STA. 1216 + 43.45



F.A.I. RTE.	SECTION	COUNTY	TOTAL SHEETS	SHEET NO.
412	(50-5B)I-1	LASALLE	29	17
FED. ROAD DIST. NO.		ILLINOIS	STATE AID PROJECT	

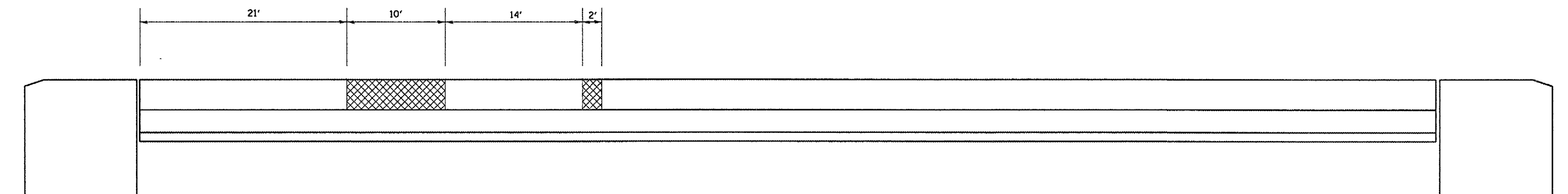

**BILL OF MATERIAL WEST PARAPET**

Item	Unit	Total
Formed Concrete Repair (Depth ≤ 5")	Sq. Ft.	36

WEST PARAPET ELEVATION  
INSIDE FACE

 FORMED CONCRETE REPAIR ≤ 5"

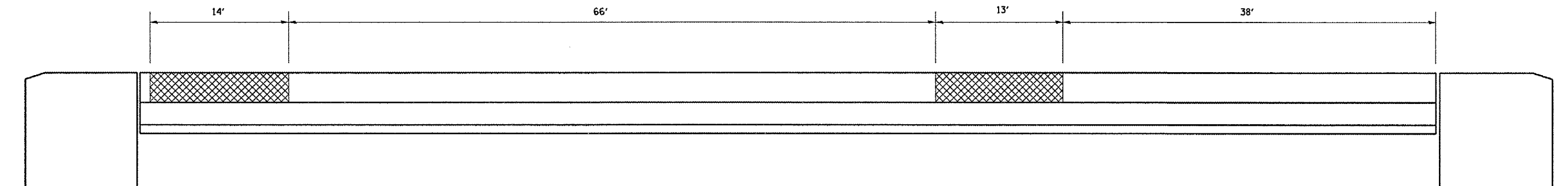

EAST PARAPET ELEVATION  
INSIDE FACE

**BILL OF MATERIAL EAST PARAPET**

Item	Unit	Total
Formed Concrete Repair (Depth ≤ 5")	Sq. Ft.	56

REVISIONS	
NAME	DATE

ILLINOIS DEPARTMENT OF TRANSPORTATION

**PARAPET WALL REPAIR**

S.N. 050-0174  
F.A.I. 412 NORTHBOUND  
OVER C. & N.W. RAILROAD  
SECTION (50-5B)I-1  
STA. 1216 + 43.45

DATE 04/24/2005

DRAWN BY RW  
CHECKED BY

MARCH 30, 2005  
C:\PROJECTS\CMAI\N06\CM303\DETAILS.DGN

F.A.I. RTE.	SECTION	COUNTY	TOTAL SHEETS	SHEET NO.
412	(50-5B)I-1	LASALLE	29	18
FED. ROAD DIST. NO.		ILLINOIS	STATE AID PROJECT	

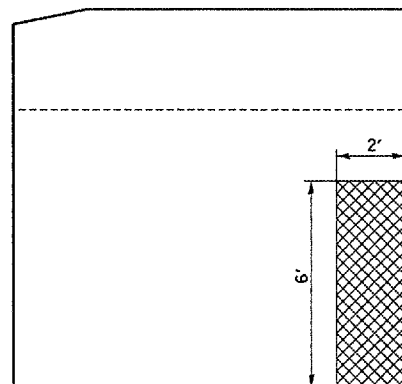

WEST WING

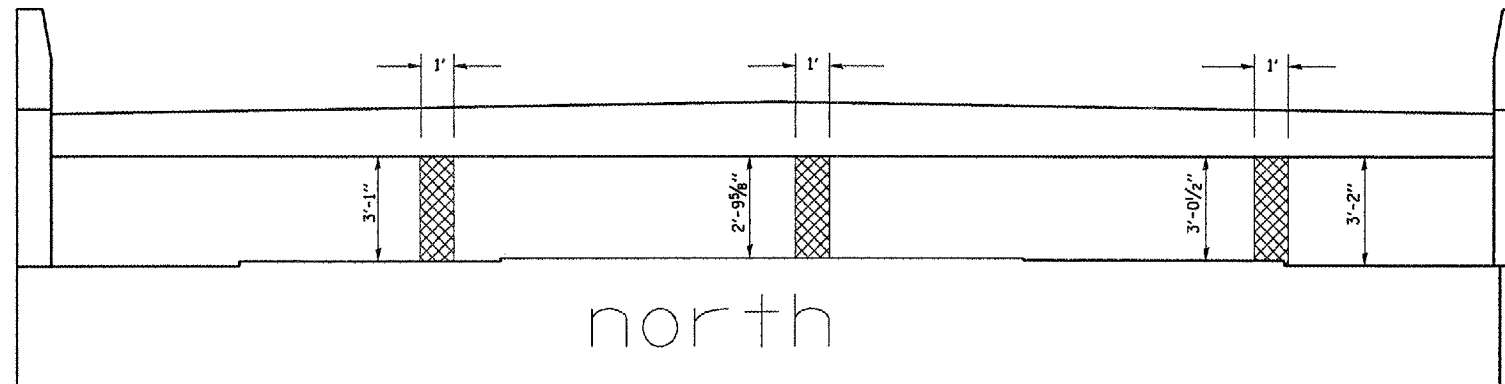

ELEVATION

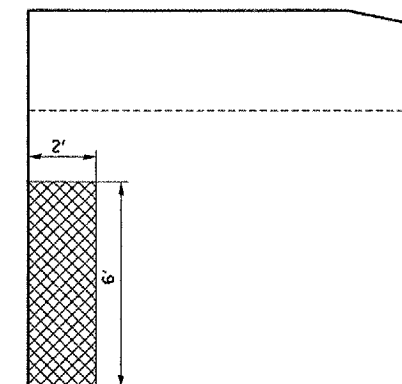

EAST WING

**BILL OF MATERIAL N. ABUTMENT**

Item	Unit	Total
Formed Concrete Repair (Depth ≤ 5")	Sq. Ft.	33

**NORTH ABUTMENT**



FORMED CONCRETE REPAIR ≤ 5"

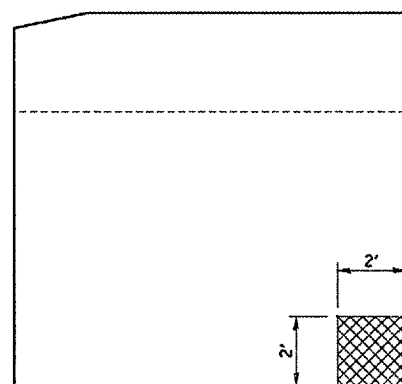

EAST WING



ELEVATION

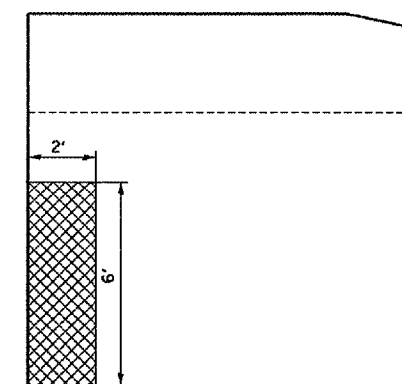

WEST WING

**BILL OF MATERIAL S. ABUTMENT**

Item	Unit	Total
Formed Concrete Repair (Depth ≤ 5")	Sq. Ft.	32

**SOUTH ABUTMENT**

REVISIONS	
NAME	DATE

ILLINOIS DEPARTMENT OF TRANSPORTATION  
**ABUTMENT WALL REPAIR**  
 S.N. 050-0174  
 F.A.I. 412 NORTHBOUND  
 OVER C. & N.W. RAILROAD  
 SECTION (50-5B)I-1  
 STA. 1216 + 43.45

DATE 04/24/2005

DRAWN BY RW  
 CHECKED BY

MARCH 30, 2005  
 C:\PROJECTS\CMA IN06\CM303\DETAILS.DGN

F.A.I. RTE.	SECTION	COUNTY	TOTAL SHEETS	SHEET NO.
412	(50-5B)I-1	LASALLE	29	19
FED. ROAD DIST. NO. _		ILLINOIS	STATE AID PROJECT	

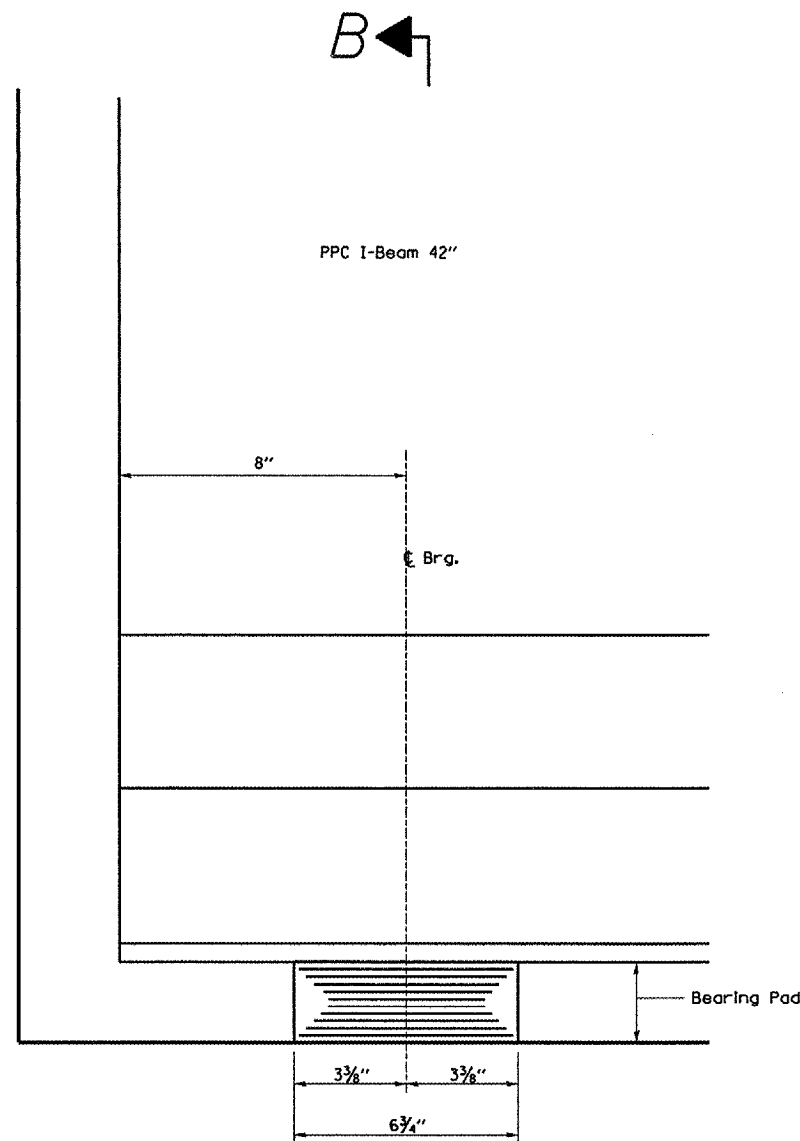

**ELEVATION AT ABUT.**

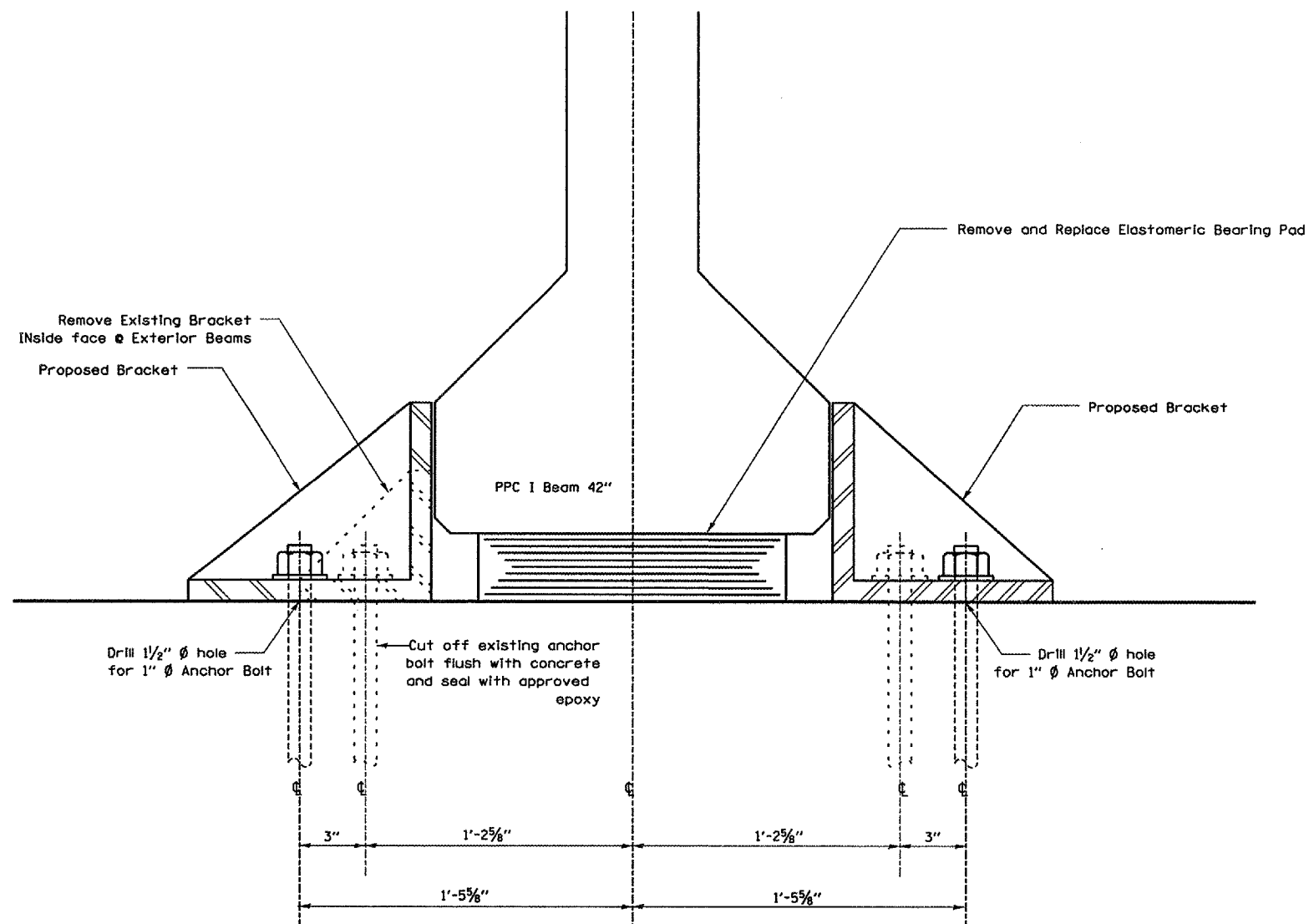

**SECTION B-B**

**Reaction for Bearing Replacement**

- R DL = 37.5 kips
- R SDL = 7.3 kips
- R LL = 38.8 kips
- R Imp = 10.1 kips

Min Jack size:  $1.5 \cdot (R DL + R SDL + 1/2(R LL + R Imp)) / 2$  in Tons

NOTE: The minimum Jack size assumes no traffic over bearings being replaced plus a 50% safety factor for the Jack.

REVISIONS	
NAME	DATE

ILLINOIS DEPARTMENT OF TRANSPORTATION  
**BEARING REPLACEMENT DETAILS**  
 S.N. 050-0174  
 F.A.I. 412 NORTHBOUND  
 OVER C. & N.W. RAILROAD  
 SECTION (50-5B)I-1  
 STA. 1216+43.45  
 DATE 04/24/2005  
 DRAWN BY RW  
 CHECKED BY

MARCH 30, 2005  
 C:\PROJECTS\CMA IN06\CM303\DETAILS.DGN

F.A.I. RTE.	SECTION	COUNTY	TOTAL SHEETS	SHEET NO.
412	(50-5B)I-1	LASALLE	29	20
FED. ROAD DIST. NO. - ILLINOIS		STATE AID PROJECT		

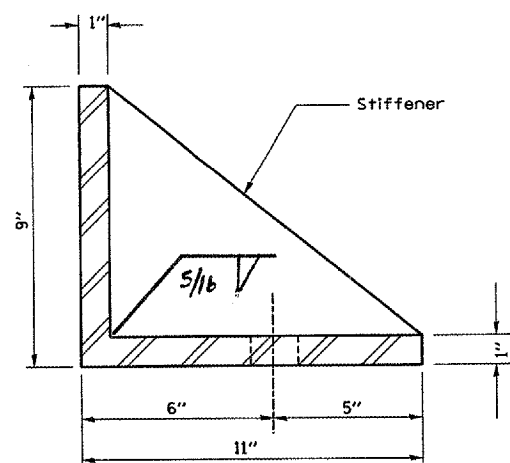

**SIDE VIEW**

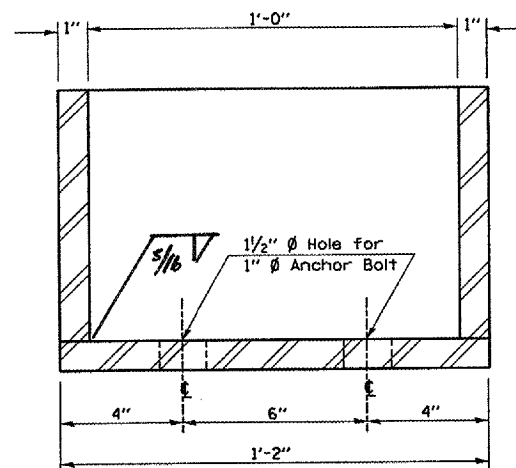

**FRONT VIEW**

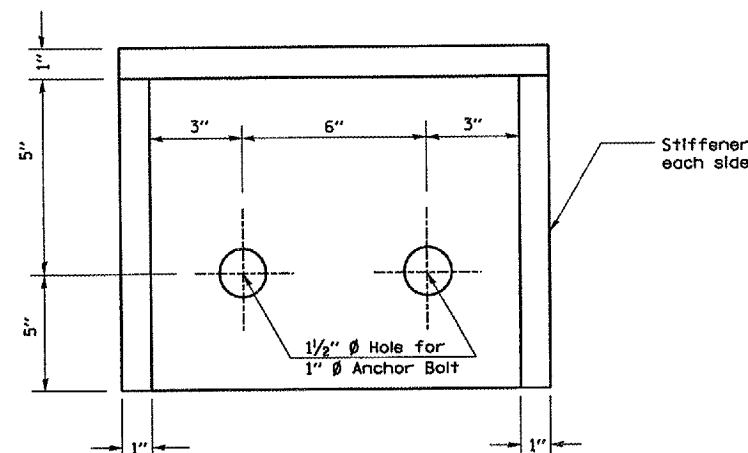

**PLAN VIEW**

The cost of the side retainers and anchor bolts is included with Elastomeric Bearing Assembly Type I.

**BRACKET DETAIL**  
 11" X 9" X 1" X 1'-2"  
 24 REQUIRED

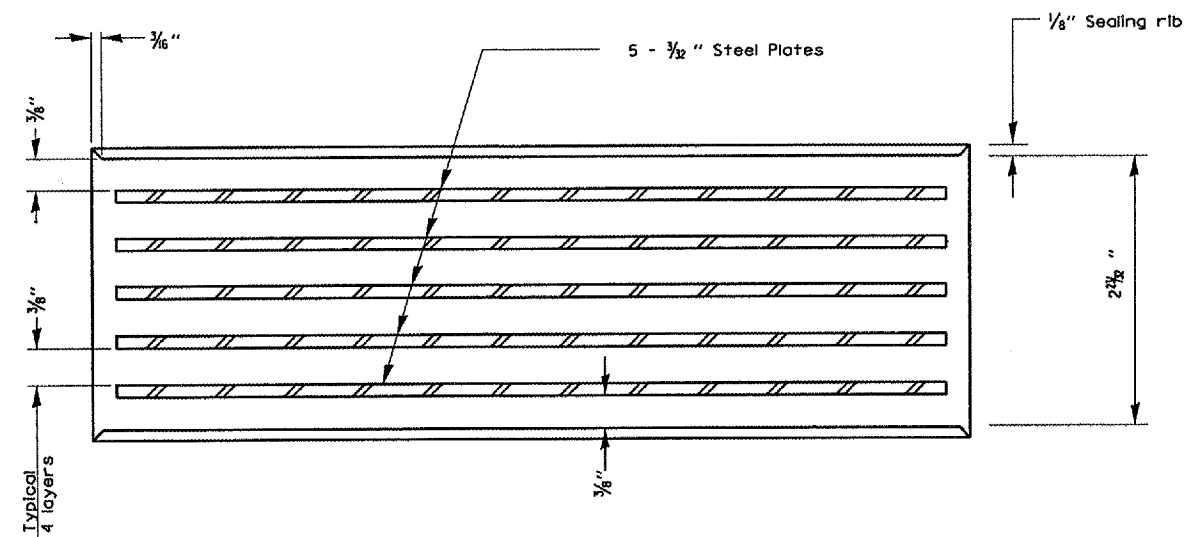

**ELASTOMERIC BEARING PAD**

2 3/8" " X 6 3/4" X 1'-6"  
 12 REQUIRED

**BILL OF MATERIAL**

Item	Unit	Total
Elastomeric Bearing Assembly Type I	Each	12

REVISIONS	
NAME	DATE

ILLINOIS DEPARTMENT OF TRANSPORTATION  
**BEARING REPLACEMENT DETAILS**  
 S.N. 050-0174  
 F.A.I. 412 NORTHBOUND  
 OVER C. & N.W. RAILROAD  
 SECTION (50-5B)I-1  
 STA. 1216 + 43.45  
 DATE - 04/24/2005  
 DRAWN BY RW  
 CHECKED BY

F.A.I. RTE.	SECTION	COUNTY	TOTAL SHEETS	SHEET NO.
412	(50-5B)I	LASALLE	29	21
FED. ROAD DIST. NO.	ILLINOIS	STATE AID PROJECT		

The Illinois Coil-Lock Anchor Bolt is a proprietary item which is the property of the Illinois Department of Transportation. Use, reproduction or disclosure without express written permission is prohibited and protected under Federal copyright laws. The production and the fabrication of this bolt for use on highway projects in the State of Illinois shall be permitted and there shall be no incurred charges or fees to the manufacturer or the fabricator for producing or fabricating this bolt.

D	E	H	K	"d"
1"	1 1/8"	1 3/16"	1 3/4"	1/4"
1 1/4"	1 3/8"	1 1/16"	2"	3/8"
1 1/2"	1 5/8"	1 5/16"	2 1/8"	1/2"
2"	2 1/8"	1 13/16"	2 7/8"	1/2"
2 1/2"	2 5/8"	2 5/16"	3 3/8"	1"

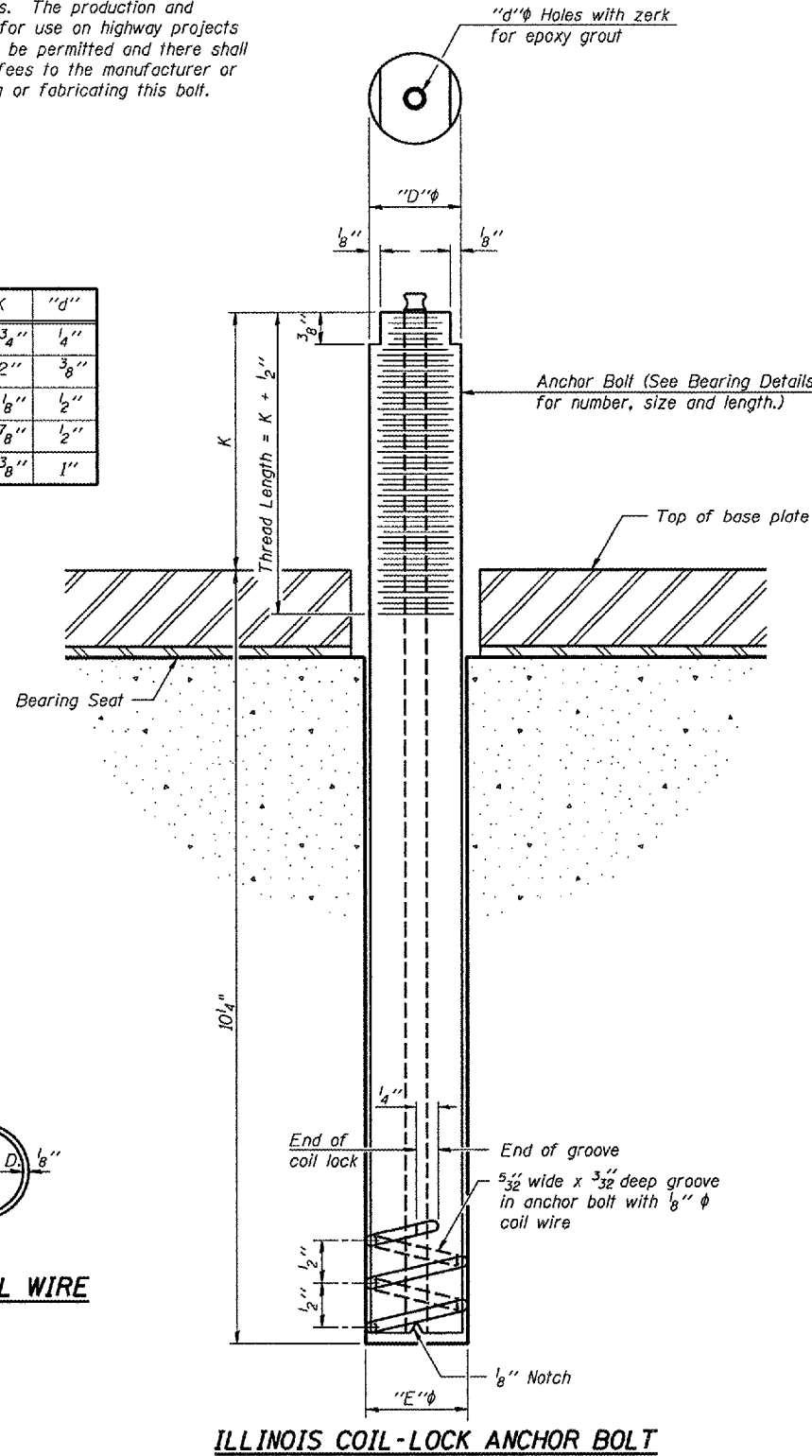

**MATERIALS FOR ILLINOIS COIL-LOCK ANCHOR BOLT**

The anchor bolt shall be fabricated from cold drawn or hot finished seamless carbon steel mechanical tubing conforming to ASTM A 519, Grade 1026, CW and supplied with hexagonal nuts and cut washers.  
 The coil wire shall be made of any suitable soft steel wire.  
 The finished anchor bolt shall be cleaned of rust and other foreign materials and wrapped or packaged to prevent contamination until they are installed.  
 The epoxy grout shall be a two-component, epoxy resin bonding system conforming to ASTM C 881, Type I, Grade 1 and of a Class suitable for the temperature at installation.

**INSTALLATION PROCEDURE for the ILLINOIS COIL-LOCK ANCHOR BOLT**

1. With the coil wire in place, the bolt shall be inserted into the hole and turned clockwise to a snug fit in the hole. Nut and washer shall be placed on the bolt. The nut shall be tensioned until the steel base plates are held securely to the concrete bearing seat.
2. Epoxy grout shall be pumped through the zerk fitting with a pressure gun. Pumping shall continue until the epoxy overflows the hole around the bolt shank. After pumping is discontinued, excess epoxy shall be immediately wiped off.

**ALTERNATE ANCHOR BOLTS**

The Contractor may use, at his option, the capsule or the adhesive cartridge type anchor rods that have been previously tested and given a prior approval by the Department. The Contractor shall install these anchor rods in pre-drilled holes according to the manufacturer's recommendations and procedures.  
 The capsule or the adhesive cartridge type anchor rods shall be a two part system composed of:  
 1. A threaded rod stud with nut and washer of the type specified.  
 2. A sealed glass capsule or a sealed glass adhesive cartridge containing premeasured amounts of the adhesive chemical.

Location	Type
Abutments	A307

ASTM F 1554 Grade 105, ASTM A 449 and AASHTO M 314 Grade 105 anchor bolts may be substituted for the anchor bolts shown above.

**GENERAL NOTES**

Holes in the masonry for anchor bolts shall be drilled through the base plates to the diameter and depth shown or according to the manufacturer's recommendation after beams or girders have been erected and adjusted.  
 Prior to setting the bolts, the holes shall be dry and all dust and loose particles shall be removed by the use of compressed air or vacuuming.  
 The anchor bolts, furnished and installed and including the epoxy grout or capsules shall not be paid for separately but shall be included in the unit bid price for Furnishing and Erecting Structural Steel.

**PLAN-COIL WIRE**

REVISIONS	
NAME	DATE

ILLINOIS DEPARTMENT OF TRANSPORTATION  
**ANCHOR BOLT DETAILS FOR BEARINGS**  
 F.A.I. 412 SOUTHBOUND  
 OVER C. & N.W. RAILROAD  
 SECTION (50-5B)I  
 STA. 1216 + 43.45

DATE 04/24/2005 DRAWN BY RW CHECKED BY

MARCH 30, 2005 C:\PROJECTS\CMA INDB\CM303\DETAILS.DGN

ABB-1 4-30-99

F.A.I. RTE.	SECTION	COUNTY	TOTAL SHEETS	SHEET NO.
412	(50-5B)I-1	LASALLE	29	22
FED. ROAD DIST. NO.		ILLINOIS	STATE AID PROJECT	

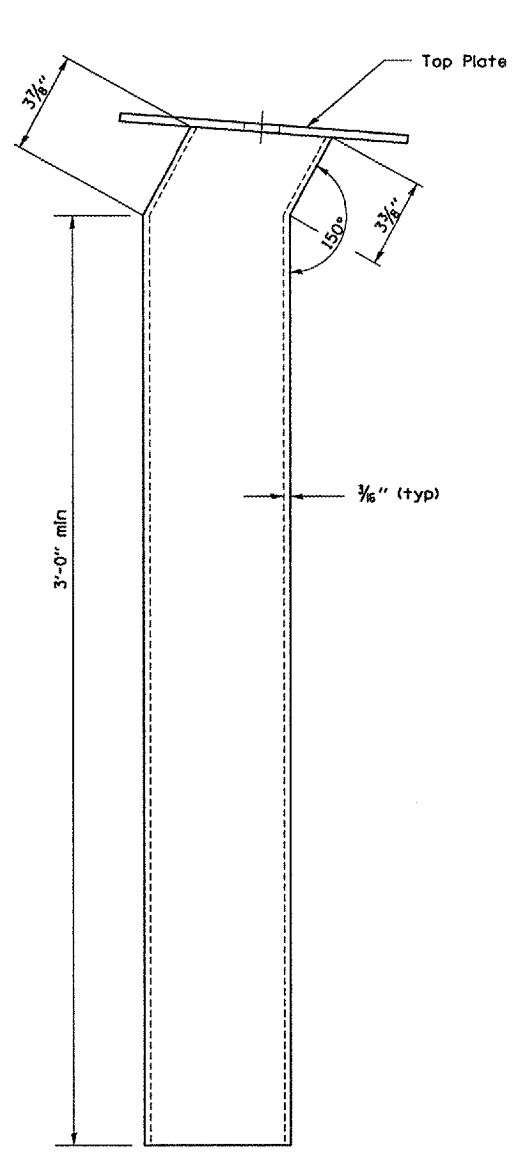

SIDE ELEVATION

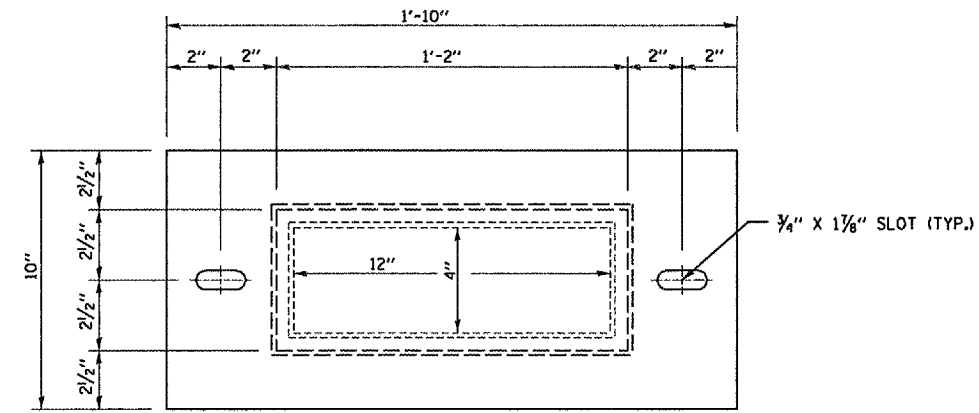

PLAN

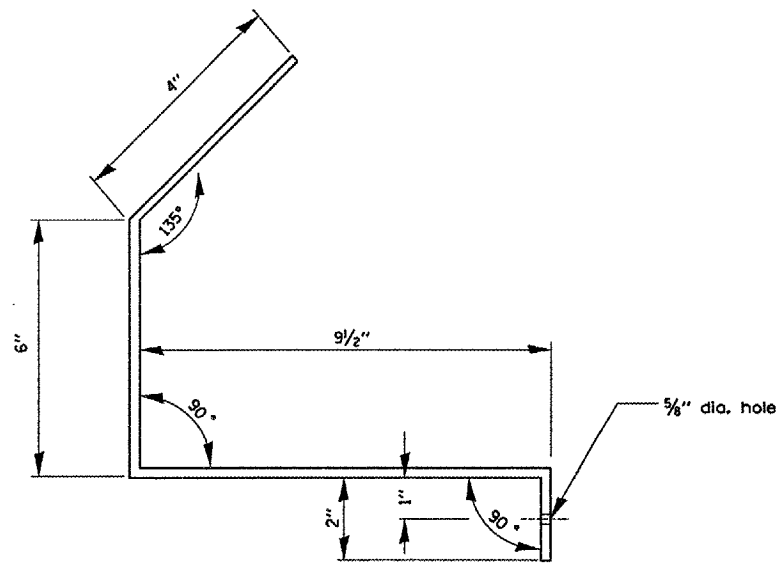

BRACKET

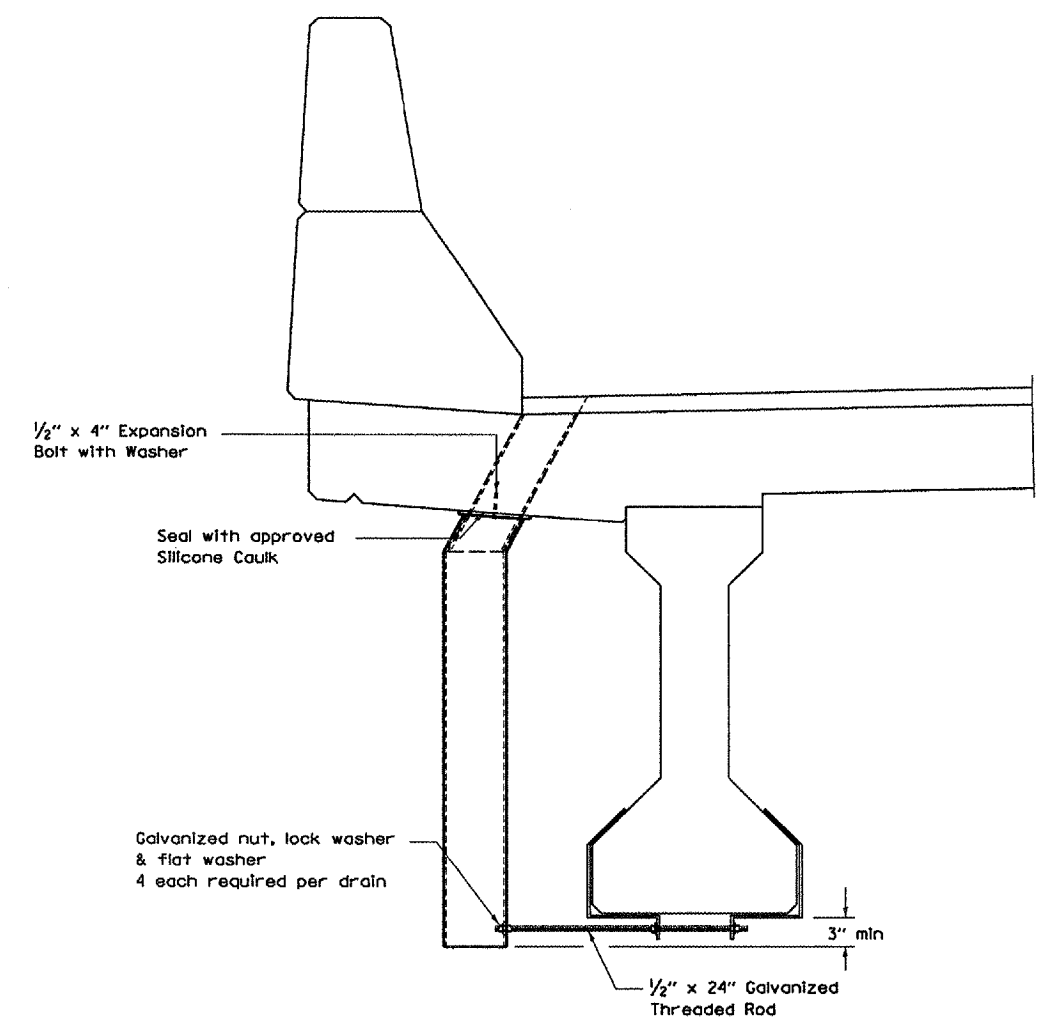

SECTION AT PARAPET

DECK DRAIN EXTENSION

REVISIONS	
NAME	DATE

ILLINOIS DEPARTMENT OF TRANSPORTATION  
**DECK DRAIN EXTENSION DETAILS**  
 F.A.I. 412 SOUTHBOUND  
 OVER C. & N.W. RAILROAD  
 SECTION (50-5B)I  
 STA. 1216 + 43.45  
 DATE 04/24/2005  
 DRAWN BY RW  
 CHECKED BY

MARCH 30, 2005  
 C:\PROJECTS\CMA\1106\CM303\DETA ILS.DGN

F.A.I. RTE.	SECTION	COUNTY	TOTAL SHEETS	SHEET NO.
412	150-5VB11-1	LASALLE	29	23
FED. ROAD DIST. NO.		ILLINOIS	STATE AID PROJECT	

**NOTES**

Bar splicer assemblies shall be of an approved type and shall develop in tension at least 125 percent of the yield strength of the lapped reinforcement bars.  
 Splicer rods shall be of minimum 60 ksi yield strength, threaded or coiled full length.  
 All reinforcement bars shall be lapped and tied to the splicer rods or dowel bars.  
 Bar splicer assemblies shall be epoxy coated according to the requirements for reinforcement bars.  
 Other systems of similar design may be submitted to the Engineer for approval. Approval shall be based on certified test results from an approved testing laboratory that the proposed bar splicer assembly satisfies the following requirements:

- ① Minimum Capacity =  $1.25 \times f_y \times A_t$   
(Tension in kips)
- ② Minimum \*Pull-out Strength =  $1.25 \times f_{sallow} \times A_t$   
(Tension in kips)

Where  $f_y$  = Yield strength of lapped reinforcement bars in ksi.  
 $f_{sallow}$  = Allowable tensile stress in lapped reinforcement bars in ksi (Service Load)  
 $A_t$  = Tensile stress area of lapped reinforcement bars.  
 \* = 28 day concrete

Bar Size to be Spliced	Splicer Rod or Dowel Bar Length	Strength Requirements	
		Min. Capacity kips - tension	Min. Pull-Out Strength kips - tension
#4	1'-8"	14.7	5.9
#5	2'-0"	23.0	9.2
#6	2'-7"	33.1	13.3
#7	3'-5"	45.1	18.0
#8	4'-6"	58.9	23.6
#9	5'-9"	75.0	30.0
#10	7'-3"	95.0	38.0
#11	9'-0"	117.4	46.8

Bar splicer assemblies shall be according to Section 508 of the Standard Specifications, except as noted. The furnishing and installation of bar splicer assemblies will be measured and paid for at the contract unit price each for "BAR SPLICERS."

The diameter of this part is equal or larger than the diameter of bar spliced.

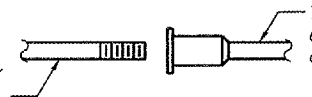

ROLLED THREAD DOWEL BAR



\*\* ONE PIECE

Wire Connector

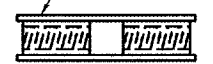

WELDED SECTIONS

**BAR SPLICER ASSEMBLY ALTERNATIVES**

\*\* Heavy Hex Nuts conforming to ASTM A 563, Grade C, D or DH may be used.

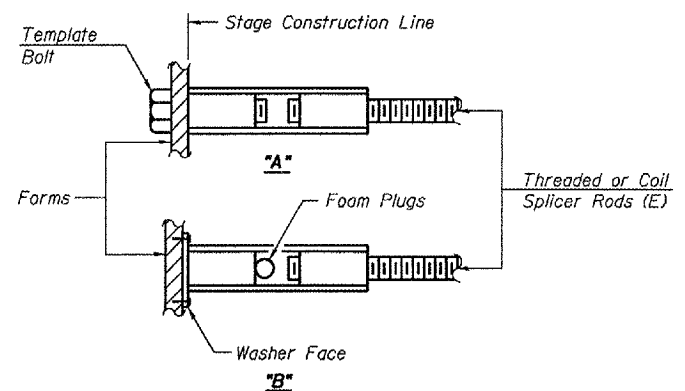

**INSTALLATION AND SETTING METHODS**

"A" : Set bar splicer assembly by means of a template bolt.  
 "B" : Set bar splicer assembly by nailing to wood forms or cementing to steel forms.  
 (E) : Indicates epoxy coating.

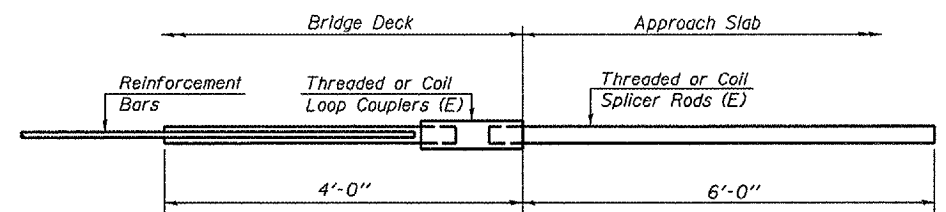

**FOR INTEGRAL OR SEMI-INTEGRAL ABUTMENTS**

Bar Splicer for #5 bar
Min. Capacity = 23.0 kips - tension
Min. Pull-out Strength = 9.2 kips - tension
No. Required =

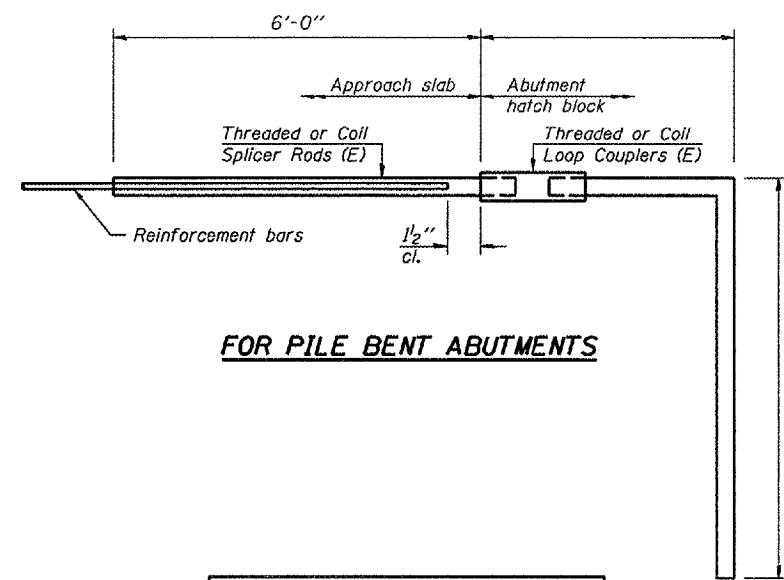

**FOR PILE BENT ABUTMENTS**

Bar Splicer for #5 bar
Min. Capacity = 23.0 kips - tension
Min. Pull-out Strength = 9.2 kips - tension
No. Required =

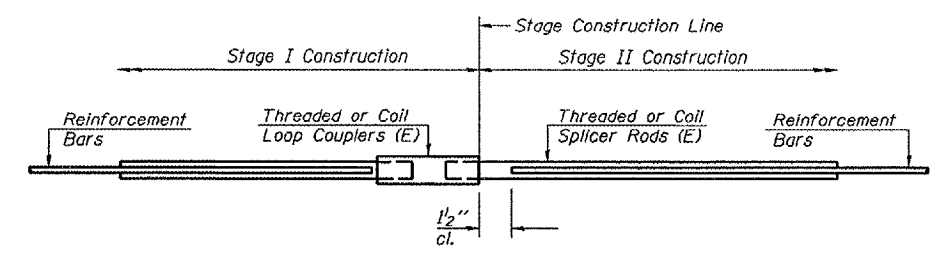

**STANDARD**

Bar Size	No. Assemblies Required	Location

REVISIONS	
NAME	DATE

ILLINOIS DEPARTMENT OF TRANSPORTATION  
**BAR SPLICER ASSEMBLY DETAILS**  
 S.N. 050-0174  
 F.A.I. 412 NORTHBOUND  
 OVER C. & N.W. RAILROAD  
 SECTION (50-5B)I-1  
 STA. 1216 + 43.45  
 DATE 04/24/2005  
 DRAWN BY RW  
 CHECKED BY

MARCH 30, 2005 C:\PROJECTS\CMA1106\CM303\DETAILS.DGN

BSD-1

10-22-04

F.A.I. RTE.	SECTION	COUNTY	TOTAL SHEETS	SHEET NO.
412	(50-5B)I-1	LASALLE	29	24
FED. ROAD DIST. NO.		ILLINOIS	STATE AID PROJECT	

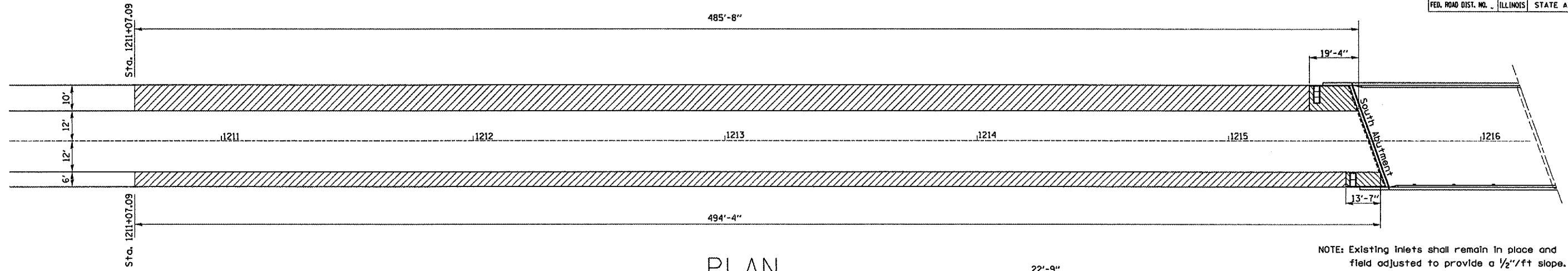

PLAN

NOTE: Existing inlets shall remain in place and field adjusted to provide a 1/2"/ft slope.

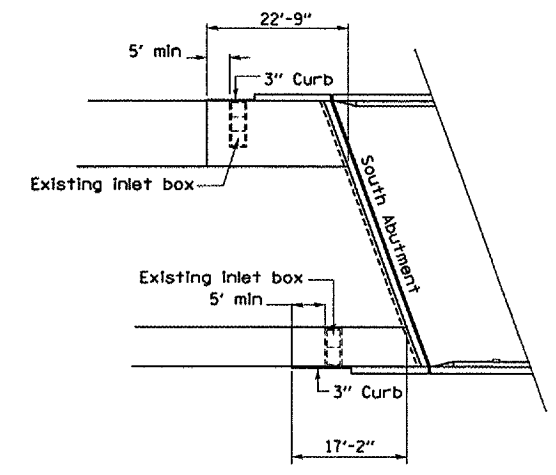

PROPOSED PLAN  
BRIDGE APPROACH SHOULDER  
See Standards 483001 & 609001 for detail not shown



- BITUMINUS SHOULDER REMOVAL & PCC SHOULDER 10"
- BRIDGE APPROACH SHOULDER REMOVAL & PCC BRIDGE APPROACH SHOULDER PAVEMENT

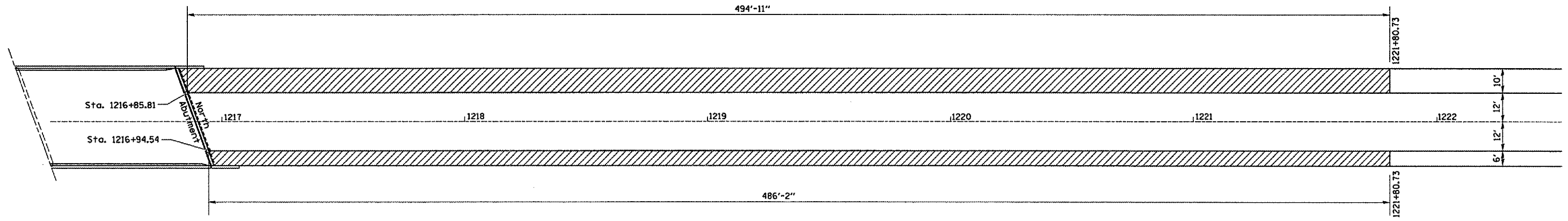

PLAN

REVISIONS	
NAME	DATE

ILLINOIS DEPARTMENT OF TRANSPORTATION  
**PRE-STAGING DETAILS**  
F.A.I. 412 NORTHBOUND  
OVER C. & N.W. RAILROAD  
SECTION (50-5B)I  
STA. 1216 + 43.45  
DATE 04/24/2005  
DRAWN BY RW  
CHECKED BY

MARCH 30, 2005  
C:\PROJECTS\CMA\NOB\CM303\DETA\ILS.DGN



F.A.I. RTE.	SECTION	COUNTY	TOTAL SHEETS	SHEET NO.
412	(50-5B)I-1	LASALLE	29	25
FED. ROAD DIST. NO.		ILLINOIS STATE AID PROJECT		

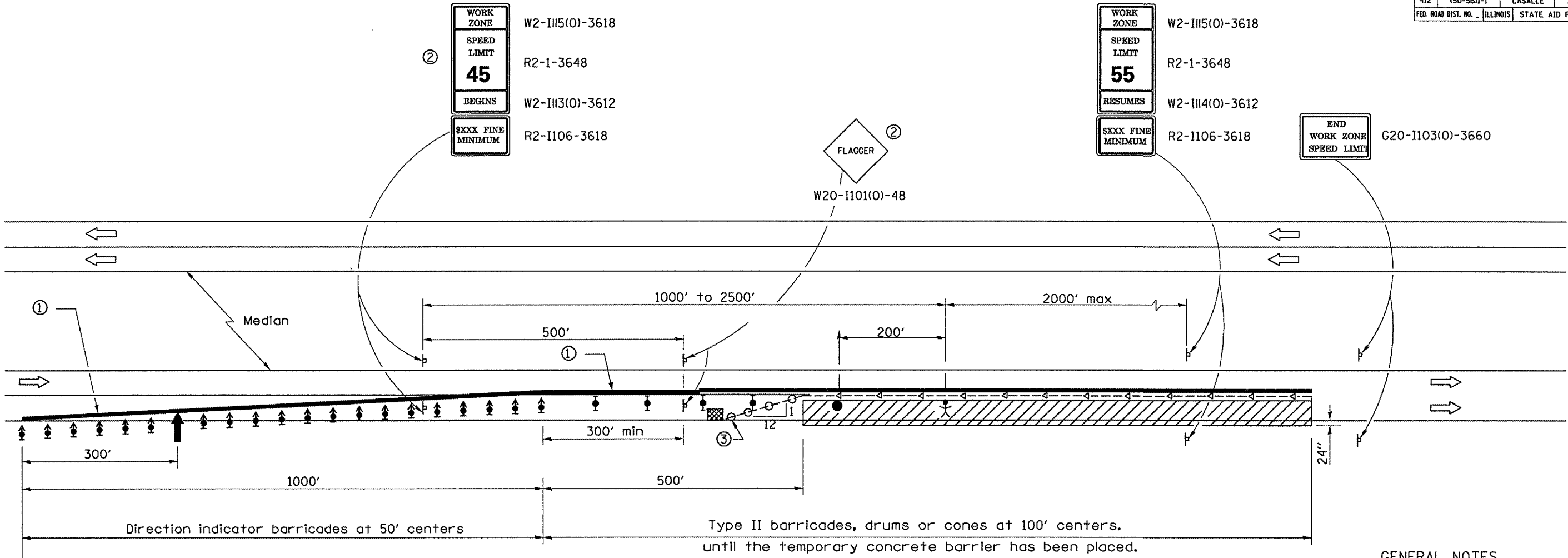

**GENERAL NOTES**

This Standard is used where at any time any vehicle, equipment, workers or their activities will encroach on the lane adjacent to the shoulder, or on the shoulder within 24" of the edge of pavement whenever temporary concrete barrier is warranted.

This Standard must always be used in combination with Standard 701400.

This Standard also applies when work is being performed in the left lane. Under these conditions, the set up would be a mirror image to what is shown.

A check barricade shall be placed in the middle of the closed lane and at the shoulder at 1000' centers.

The cost of materials, equipment and labor to utilize this traffic control and protection as shown will be paid for at the contract unit bid price for TRAFFIC CONTROL AND PROTECTION, STANDARD 701402 (SPECIAL) and no further compensation will be allowed.

Temporary concrete barrier shall be paid for according to Section 704 of the Standard Specifications.

**SYMBOLS**

- ↑ Arrow board
- ▨ Work area
- ⊗ Worker
- ⊥ Sign
- ⬆ Direction indicator barricade with steady burn monodirectional light
- ⬇ Type II barricade, drum, or vertical barricade with steady burn monodirectional light
- Flagger with traffic control sign
- Temporary concrete barrier
- ◁ Type C Monodirectional reflector
- Vertical panel with steady burn monodirectional light.
- ▣ Impact attenuator

- ① ReflectORIZED temporary pavement marking tape shall be placed throughout the taper and along-side the temporary concrete barrier. The edge line shall be white for right lane closure and yellow for left lane closures. Temporary raised reflectORIZED pavement markers at 25' centers shall be used to supplement the pavement marking tape.
- ② Type II barricades, drums or cones shall be used alongside the tangent portion of the work zone to provide protection during the installation of the temporary concrete barrier. Work Zone speed limit signs and FLAGGER signs shall be covered after the temporary concrete barrier is in place and uncovered when the temporary concrete barrier is removed and replaced with Type II barricades, drums or cones to maintain the lane closure. The additional drums, Type II barricades or cones, required shall be included in the cost of Traffic Control and Protection, Standard 701402 (Special).
- ③ Vertical panels at 25' centers with steady burning monodirectional lights.

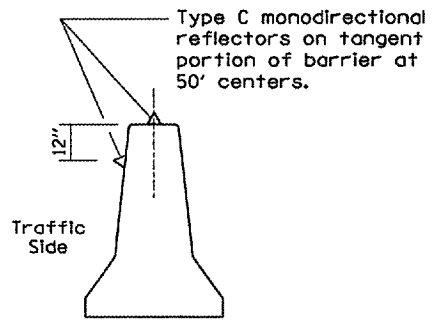

**DETAIL A**  
(BARRIER WALL REFLECTORS)

See Standard 701400 for approach Start of lane closure taper

REVISIONS	
NAME	DATE

ILLINOIS DEPARTMENT OF TRANSPORTATION  
**TRAFFIC CONTROL & PROTECTION**  
**STANDARD 701402 (SPECIAL)**  
S.N. 050-0174  
F.A.I. 412 NORTHBOUND  
OVER C. & N.W. RAILROAD  
SECTION (50-5B)I-1  
SCALE: VERT. STA. 1216 + 43.45  
HORIZ. DATE 04/18/05  
DRAWN BY RW  
CHECKED BY

MARCH 30, 2005  
C:\PROJECTS\CMA\IN06\CM303\DETAILS.DGN

F.A.I. RTE.	SECTION	COUNTY	TOTAL SHEETS	SHEET NO.
412	(50-5B)I-1	LASALLE	29	26
FED. ROAD DIST. NO.		ILLINOIS	STATE AID PROJECT	

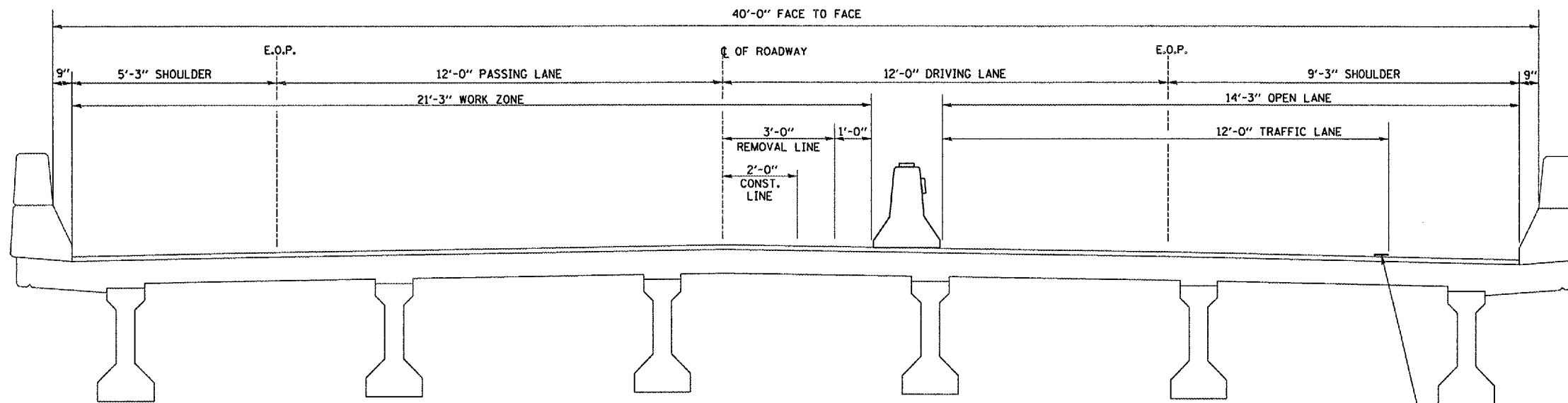

**STAGE I**

TEMPORARY PAVEMENT MARKING LINE 4" (TYP.)

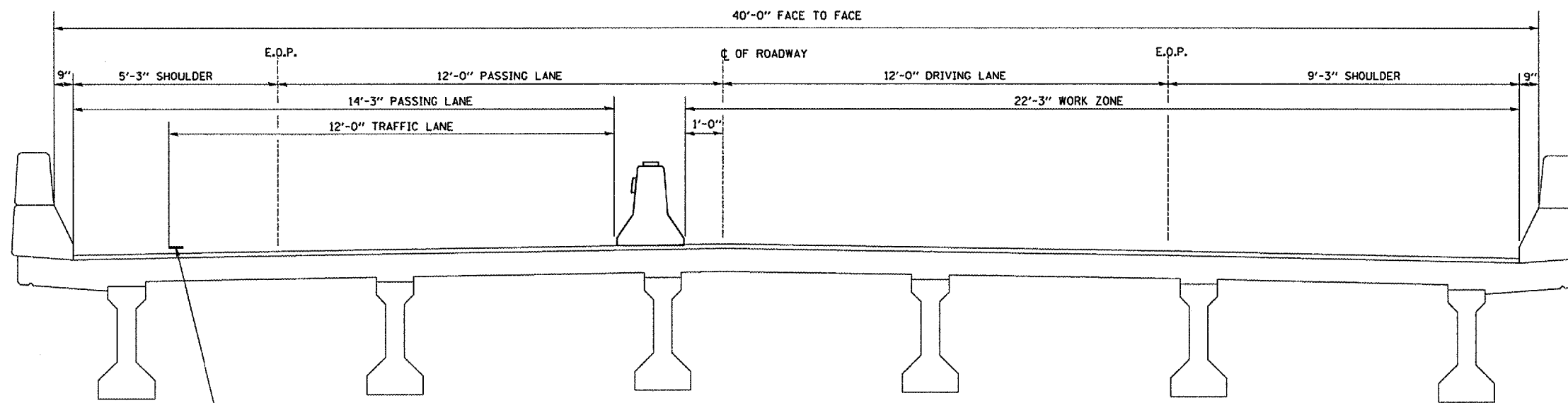

**STAGE II**

TEMPORARY PAVEMENT MARKING LINE 4" (TYP.)

MARCH 30, 2005 C:\PROJECTS\CMA\106\CM303\DETAILS.DGN

REVISIONS	
NAME	DATE

ILLINOIS DEPARTMENT OF TRANSPORTATION  
**STAGING & TRAFFIC CONTROL**  
**TYPICALS**  
 S.N. 050-0174  
 F.A.I. 412 NORTHBOUND  
 OVER C. & N.W. RAILROAD  
 SECTION (50-5B)I-1  
 DATE 04/24/2005 STA. 1216+43.45 DRAWN BY RW CHECKED BY

F.A.I. RTE.	SECTION	COUNTY	TOTAL SHEETS	SHEET NO.
412	(50-5B)I-1	LASALLE	29	27
FED. ROAD DIST. NO. ILLINOIS		STATE AID PROJECT		

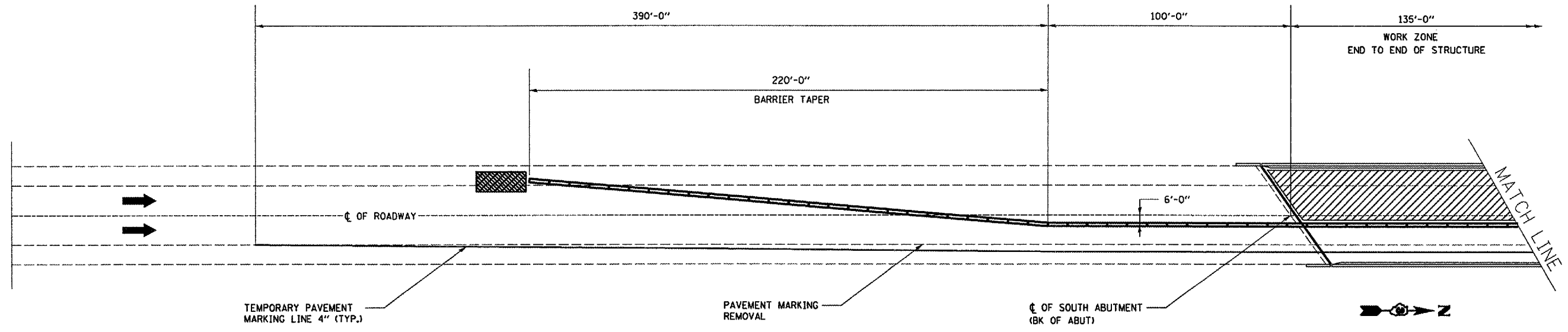

**PLAN**

- LEGEND**
- TEMPORARY CONCRETE BARRIER
  - WORK ZONE
  - IMPACT ATTENUATOR

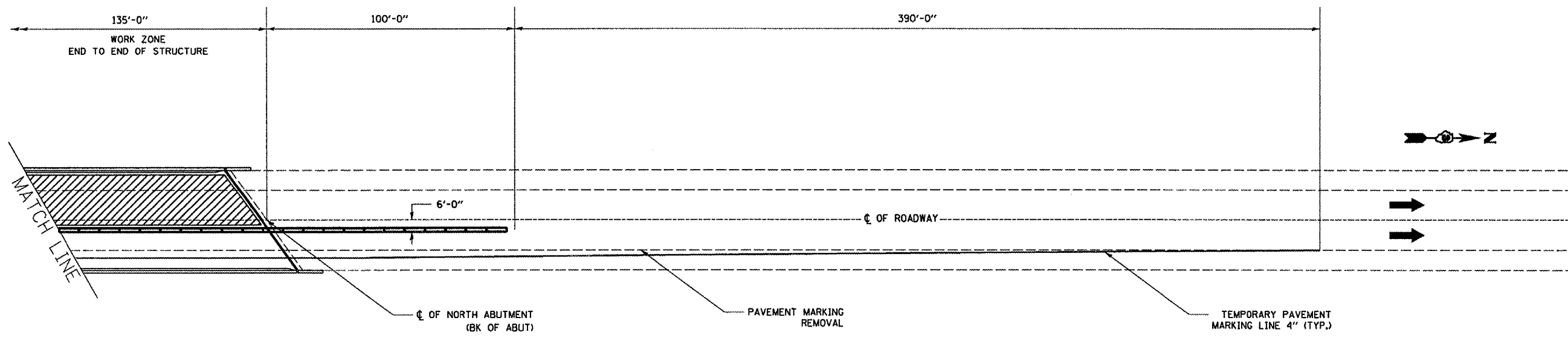

**PLAN**

WORK THIS SHEET WITH TRAFFIC CONTROL AND PROTECTION STANDARD 701402 (SPECIAL)

REVISIONS	
NAME	DATE

ILLINOIS DEPARTMENT OF TRANSPORTATION  
**TEMPORARY CONCRETE BARRIER**  
**STAGE I**  
 S.N. 050-0174  
 F.A.I. 412 NORTHBOUND  
 OVER C. & N.W. RAILROAD  
 SECTION (50-5B)I-1  
 STA. 1216 + 43.45  
 DATE 04/24/2005  
 DRAWN BY RW  
 CHECKED BY

MARCH 30, 2005  
 C:\PROJECTS\CMA IN06\CM303\DETAILS.DGN

F.A.I. RTE.	SECTION	COUNTY	TOTAL SHEETS	SHEET NO.
412	(50-5B)I-1	LASALLE	29	28
FED. ROAD DIST. NO. ILLINOIS		STATE AID PROJECT		

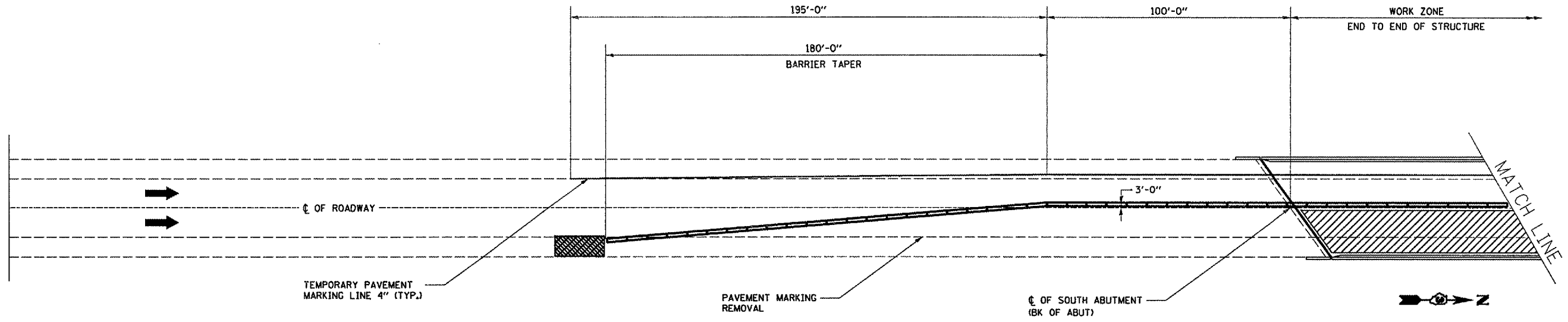

**PLAN**

**LEGEND**

- TEMPORARY CONCRETE BARRIER
- WORK ZONE
- IMPACT ATTENUATOR

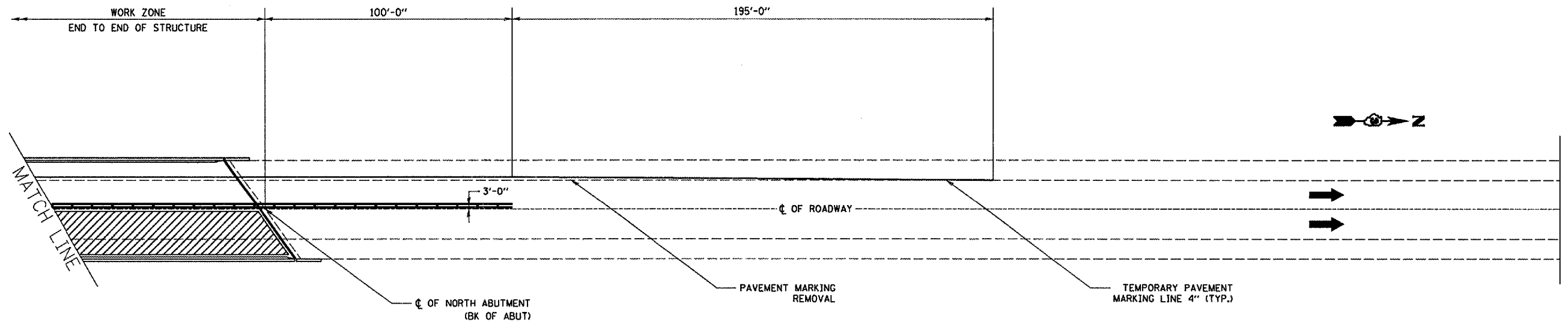

**PLAN**

WORK THIS SHEET WITH TRAFFIC CONTROL AND PROTECTION STANDARD 701402 (SPECIAL)

REVISIONS	
NAME	DATE

ILLINOIS DEPARTMENT OF TRANSPORTATION  
**TEMPORARY CONCRETE BARRIER**  
**STAGE II**  
 S.N. 050-0174  
 F.A.I. 412 NORTHBOUND  
 OVER C. & N.W. RAILROAD  
 SECTION (50-5B)I-1  
 DATE 04/24/2005 STA. 1216 + 43.45  
 DRAWN BY RW  
 CHECKED BY

MARCH 30, 2005  
 C:\PROJECTS\CMA IN06\CM303\DETAILS.DGN

F.A.I. RTE.	SECTION	COUNTY	TOTAL SHEETS	SHEET NO.
412	(50-5B)I-1	LASALLE	29	29
FED. ROAD DIST. NO.		ILLINOIS	STATE AID PROJECT	

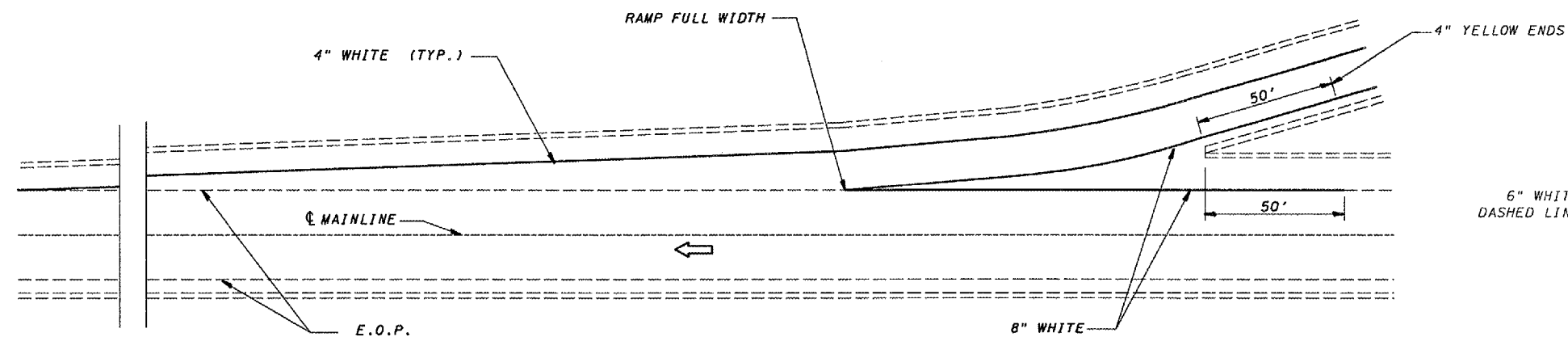

**TYPICAL PAVEMENT MARKING FOR ENTRANCE RAMP TERMINALS**

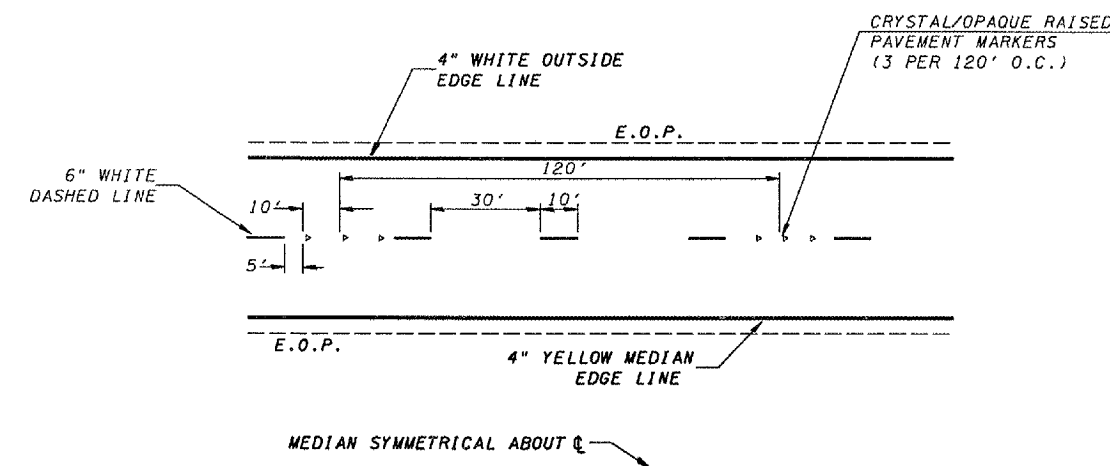

**TYPICAL PAVEMENT MARKINGS**

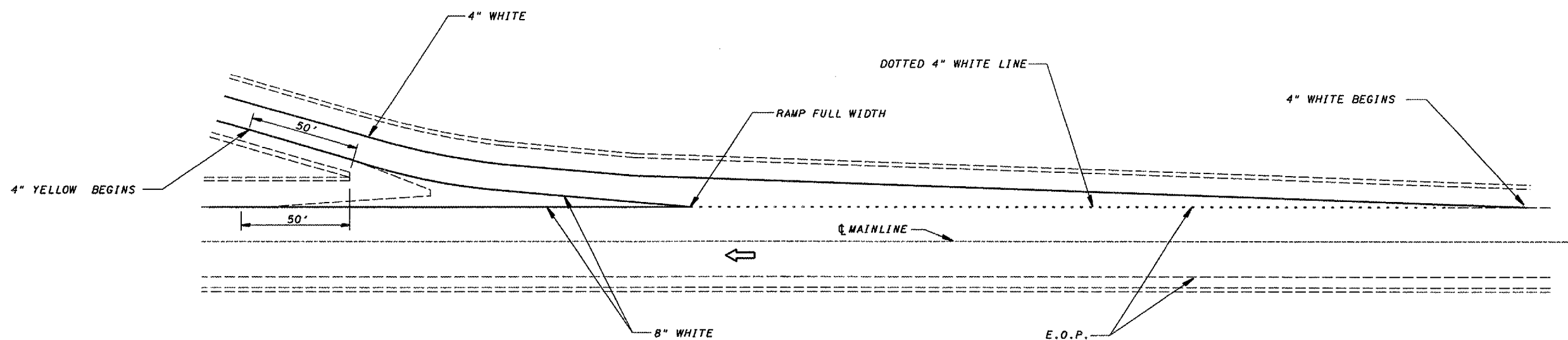

**TYPICAL PAVEMENT MARKINGS FOR EXIT RAMP TERMINALS**

REVISIONS	
NAME	DATE

ILLINOIS DEPARTMENT OF TRANSPORTATION

**TYPICAL PAVEMENT MARKING**

S.N. 050-0174  
 F.A.I. 412 NORTHBOUND  
 OVER C. & N.W. RAILROAD  
 SECTION (50-5B)I-1  
 STA. 1216 + 43.45

DATE 04/24/2005

DRAWN BY RW  
 CHECKED BY

MARCH 30, 2005  
 C:\PROJECTS\OMA IN06\CM303\DETAILS.DGN