

ROUTE NO.	SECTION	COUNTY	TOTAL SHEETS	SHEET NO.
T.R. 39	99-01123-00-BR	CUMBERLAND	11	6
ROAD DISTRICT	ILLINOIS	COTTONWOOD		

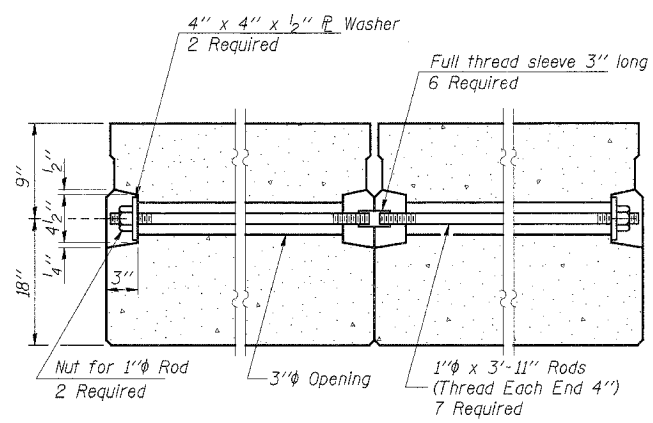

TYPICAL TRANSVERSE TIE ASSEMBLY

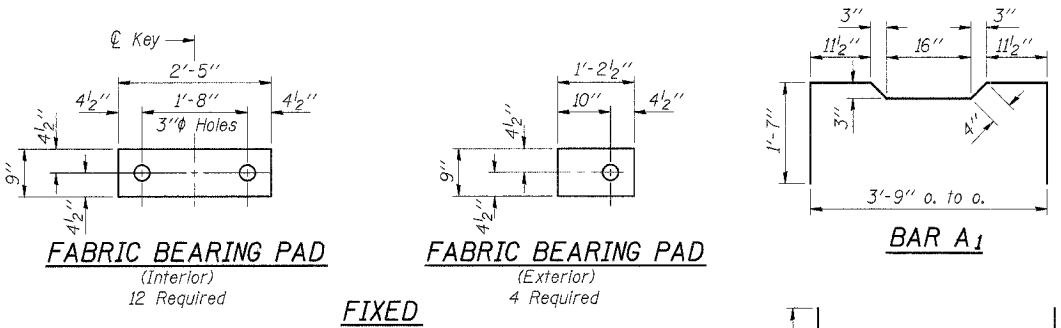
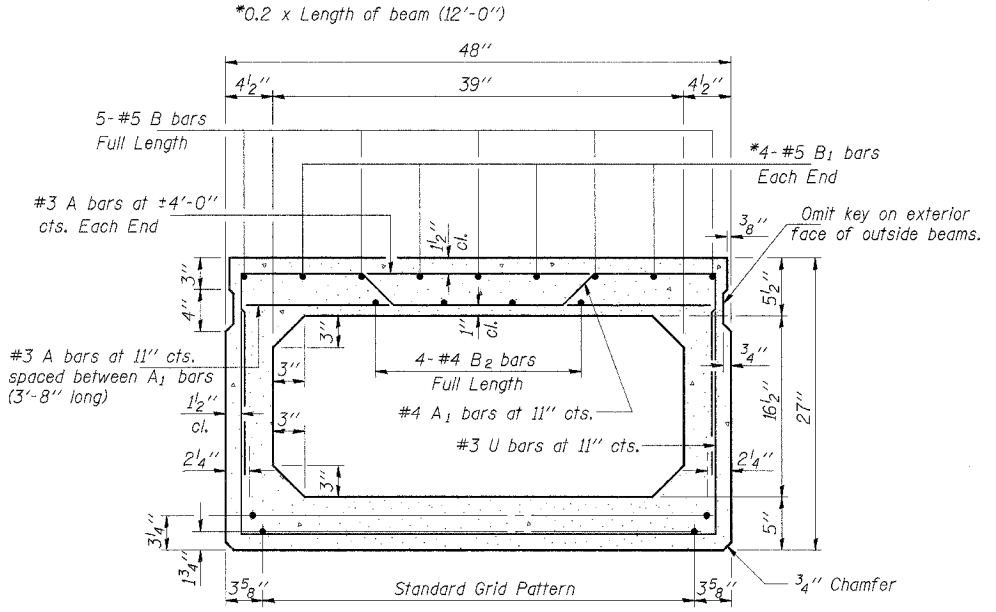

TYPICAL SECTION  
17-1/2" Strands Each Strand Stressed to 28,900 Lbs.  
14-Strands 1 3/4" up, 3-Strands 3/4" up

Note: Place strands symmetrically about centerline of beam.

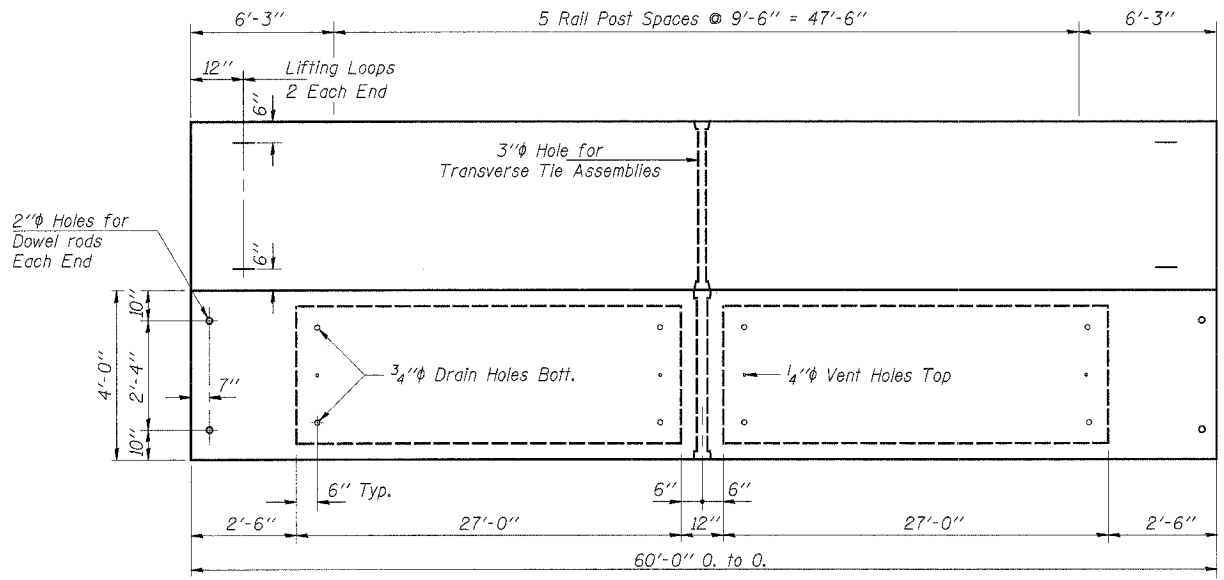

PLAN

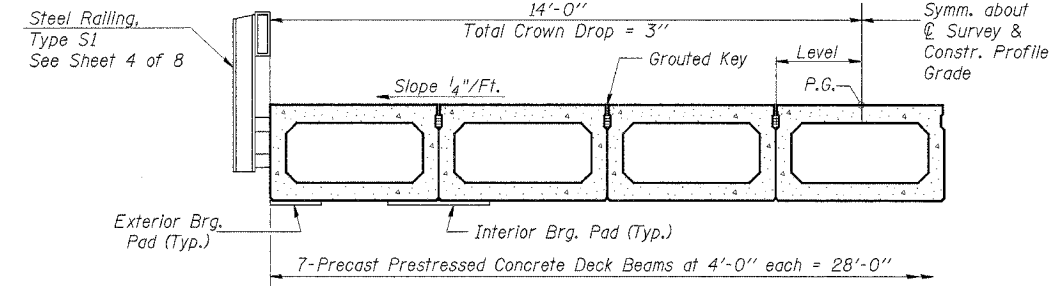

HALF CROSS SECTION

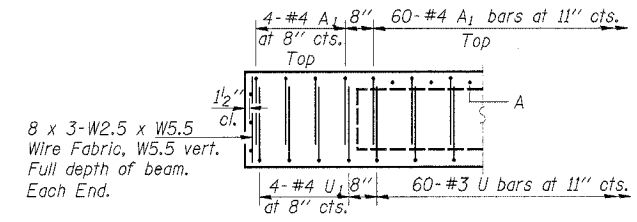

END ELEVATION

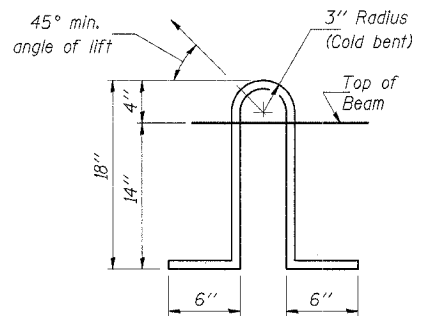

LIFTING LOOP DETAIL

DESIGNED	M.E.B.
CHECKED	F.J.S.
DRAWN	R.S.J.
CHECKED	F.J.S.

NOTES

Prestressing steel shall be uncoated high strength, stress-relieved 7-wire strand, Grade 270. The nominal diameter shall be 1/2" and the nominal cross-sectional area shall be 0.153 sq. in. Lifting loops shall be 3-1/2" φ-270 ksi strands, as shown. The 1" φ rods in the transverse tie assembly shall be tightened to a snug fit and the threads set. Pockets that receive transverse tie bar on outside shall be filled with grout after transverse tie assembly is in place. Reinforcement bars shall conform to the requirements of AASHTO M-31, M-42 or M-53 Grade 60. The bearing seat surfaces shall be adjusted by shimming to assure firm and even bearing. Two 1/8" fabric adjusting shims of the dimensions of the Exterior Bearing Pad shall be provided for each bearing. (32 Required) Keyway surfaces shall be cleaned to remove form oil or other bond breaking material prior to shipment of the beams. Cleaning shall be done by sandblasting the keyway areas between top of the beam and the bottom edge of the key. Required Release Strength, f'ci, shall be 4000 p.s.i. An equal substitution of the low-relaxation strands for the stress-relieved strands will be permitted. Longitudinal shear keys shall be grouted with an approved non-shrink grout. See Special Provisions for review and distribution of shop drawings. Rail post anchor devices shall be cast into outside beam as elsewhere specified.

BILL OF MATERIAL

Item	Unit	Quantity
Precast Prestressed Concrete Deck Beams (27" Depth)	Sq. Ft.	1,680

Estimated Total Weight (One Beam) = 47,050 Pounds

**SUPERSTRUCTURE - SPAN 2**

SECTION 99-01123-00-BR  
COTTONWOOD ROAD DISTRICT  
CUMBERLAND COUNTY  
STATION 5+09.25

4440 ASH GROVE SPRINGFIELD, IL 62707 (217) 793-8600 oasinc@famvid.com	<b>OZYURT AND STONE, INC.</b> CONSULTING ENGINEERS
JOB NO.: 0018.5 FILE: SUPER2.DGN DATE: 02-19-03	