

STATE OF ILLINOIS  
DEPARTMENT OF TRANSPORTATION  
DIVISION OF HIGHWAYS  
**PLANS FOR PROPOSED  
FEDERAL-AID SECONDARY PROJECT**

F.A.S. 888 (CH 8) SECTION 05-00098-00-RS WHITE COUNTY

PROJECT RS-888(121) JOB NO. C-97-044-05

F.A.S.	SECTION	COUNTY	TOTAL SHEETS	SHEET NO.
888	05-00098-00-RS	WHITE	4	1
FED. ROAD DIST. NO. 7		ILLINOIS	HERALD ROAD	
LEC JOB # H051006WH			CONTRACT NO. 95434	

**INDEX OF SHEETS**

SHEET NO.	DESCRIPTION
1	TITLE SHEET
2	TYPICAL SECTIONS, SUMMARY OF QUANTITIES, GENERAL NOTES, MISCELLANEOUS DETAILS
3	DETAILS OF INTERSECTIONS, AND SIDEROADS
4	SCHEDULES

**THE FOLLOWING STANDARDS ARE A PART OF THESE PLANS AND ARE INCLUDED AFTER SHEET NO. 4**

000001-04	STANDARD SYMBOLS, ABBREVIATIONS & PATTERNS
406201	MAILBOX TURNOUT
701006-02	OFF-RD OPERATIONS, 2-L, 2-W, 4.5 m (15') TO PAVEMENT EDGE FOR SPEEDS $\geq$ 45 MPH
701301-02	LANE CLOSURE, 2L, 2W, SHORT TIME OPERATIONS
701306-01	LANE CLOSURE, 2L, 2W, SLOW MOVING OPERATIONS DAY ONLY FOR SPEEDS $\geq$ 45 MPH
701311-02	LANE CLOSURE, 2L, 2W, MOVING DAY OPERATIONS
701336-04	LANE CLOSURE 2L, 2W, WORK AREAS IN SERIES FOR SPEEDS $\geq$ 45 MPH
702001-05	TRAFFIC CONTROL DEVICES
780001-01	TYPICAL PAVEMENT MARKINGS
781001-02	TYPICAL APPLICATIONS RAISED REFLECTIVE PAVEMENT MARKERS

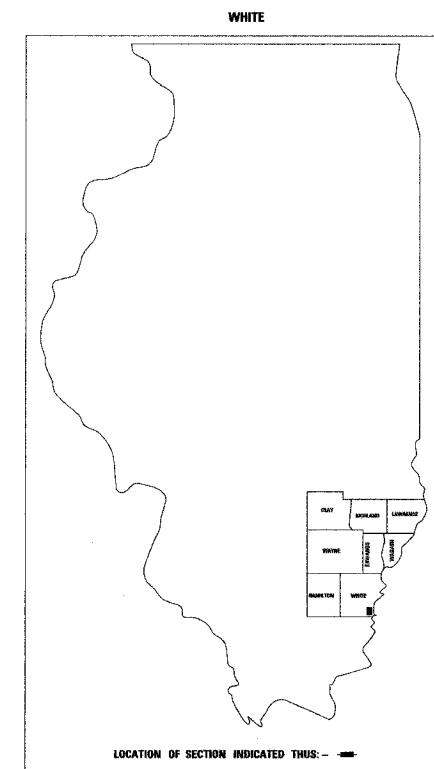
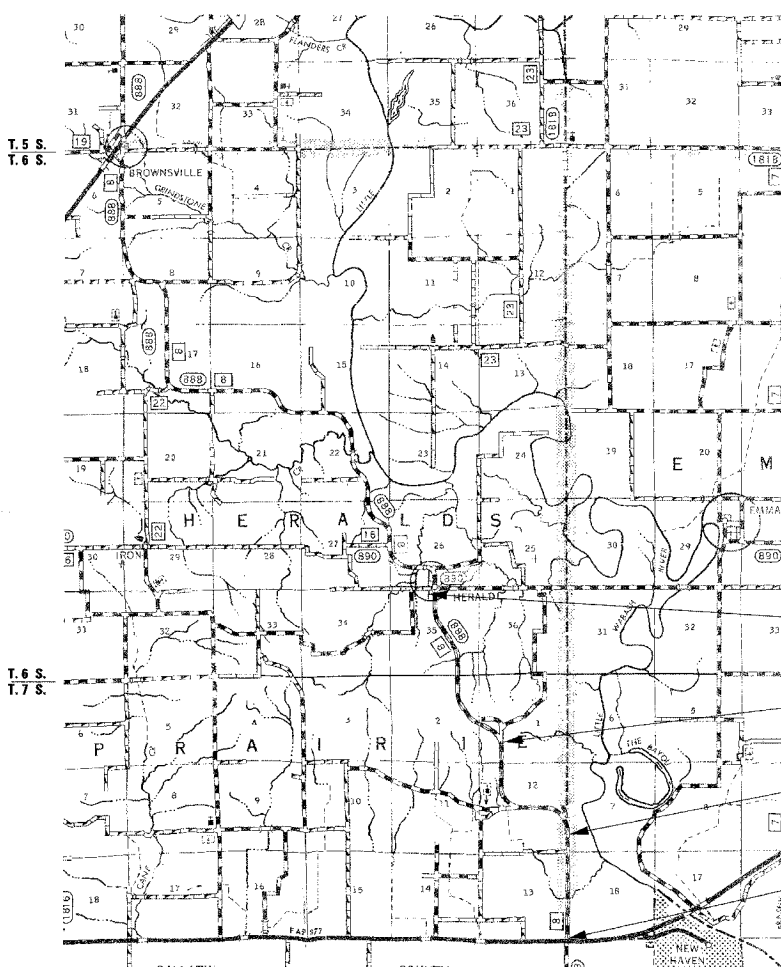

323 W. 3RD ST.  
P.O. BOX 160  
MT. CARMEL, IL  
62863  
PHONE:  
(618)-262-8661  
FAX:  
(618)-263-3327

405 W. STATE ST.  
SUITE 1  
PRINCETON, IN  
47670  
PHONE:  
(812)-386-7611  
FAX:  
(812)-385-2812



PROFESSIONAL  
DESIGN FIRM  
LAND SURVEY &  
PROFESSIONAL  
ENGINEERING  
CORPORATION  
184-00087  
(62-032435)(35-002769)

PLANS  
REVIEWED & APPROVED

*Jack Bosaw*  
COUNTY ENGINEER

5-10-05  
DATE

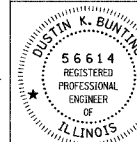

DUSTIN K. BUNTING  
NAME  
*Dustin K. Bunting*  
SIGNATURE  
05-09-05  
DATE  
11-30-05  
EXPIRES

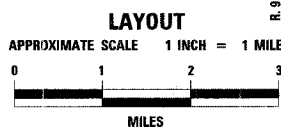

GROSS LENGTH	25,743.9 FT	4.8757 MILES
OMISSION	0 FT	0 MILES
NET LENGTH	25,743.9 FT	4.8757 MILES

THE ACCEPTANCE OF THIS PROJECT IS BASED ON THE MINIMUM DESIGN CRITERIA FOR A FEDERAL-AID L.A.P.P. TYPE IMPROVEMENT ON THE COUNTY HIGHWAY SYSTEM.

*Maurice D. Kest*  
DISTRICT ENGINEER OF LOCAL ROADS & STREETS

STATE OF ILLINOIS DEPARTMENT OF TRANSPORTATION	
PASSED	<i>Maurice D. Kest</i> 5-31 20 05 DISTRICT ENGINEER OF LOCAL ROADS & STREETS
APPROVED	<i>Christine M. Reed</i> 5-31 20 05 DEPUTY DIRECTOR OF HIGHWAYS/REGION 4 ENGINEER

CONTRACT NO. 95434  
DESIGN CLASS - MAJOR COLLECTOR  
CURRENT A.D.T. = 500  
DESIGN SPEED = 50 MPH

J.U.L.I.E.  
JOINT UTILITY LOCATION INFORMATION FOR EXCAVATION  
1-800-892-0123

F.A.S.	SECTION	COUNTY	TOTAL SHEETS	SHEET NO.
888	05-00000-00-BS	WHITE	4	2
FED. ROAD DIST. NO. 7		ILLINOIS	HERALD ROAD	
LEC JOB # 0801006WH			CONTRACT NO. 95434	

**TYPICAL CROSS SECTION EXISTING**

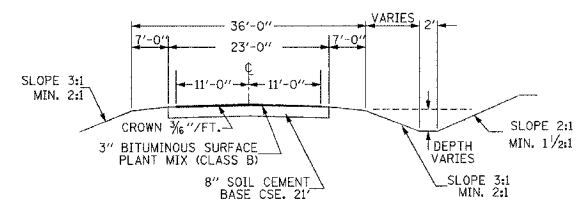

**TYPICAL CROSS SECTION PROPOSED**

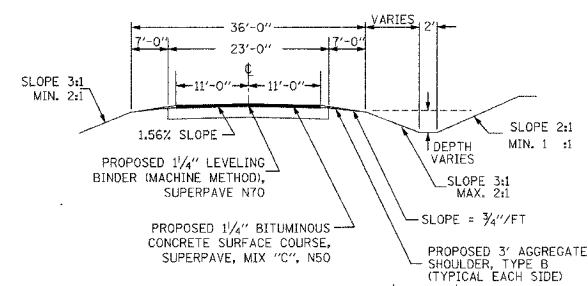

**GENERAL NOTES:**

THIS SECTION CONSISTS OF PAVEMENT REMOVAL AND REPLACEMENT SPECIAL, LEVELING BINDER (MACHINE METHOD), AND BITUMINOUS CONCRETE SURFACE COURSE, SUPERPAVE, MIX "C", NSO, AGGREGATE SHOULDERS, AND OTHER MISCELLANEOUS ITEMS NECESSARY TO COMPLETE THE PROJECT, ALL IN ACCORDANCE WITH THE PLANS, SPECIAL PROVISIONS AND "STANDARD SPECIFICATIONS FOR ROAD AND BRIDGE CONSTRUCTION" ADOPTED JANUARY 1, 2002.

THE EXISTING GRADE, ALIGNMENT, DRAINAGE STRUCTURES, BASE AND SURFACE WERE CONSTRUCTED UNDER SECTION 40-0 AND SHALL REMAIN IN PLACE. ALL STATIONS REFERRED TO IN THE PLANS AND PROPOSAL ARE REFERENCED TO THE ABOVE MENTIONED SECTIONS.

MAXIMUM PERCENT OF GRADE	-6.00 %
MINIMUM STOPPING SIGHT DISTANCE	400 FT
DESIGN SPEED	60 MPH
CURRENT ADT	500 VPD
DESIGN ADT (20 YEAR)	650 VPD

THE QUANTITY SHOWN IN THE SUMMARY OF QUANTITIES FOR BITUMINOUS CONCRETE SURFACE COURSE, SUPERPAVE, MIX "C", NSO ALLOWS 151.6 TON FOR THE INTERSECTIONS, SIDEROADS, AND TAPERS; 197.8 TON FOR THE ENTRANCES; 89.3 TON FOR THE MAILBOX TURNOUTS, AND 4396.8 TON FOR THE 1/2" BITUMINOUS CONCRETE SURFACE COURSE, SUPERPAVE, MIX "C", NSO.

A BITUMINOUS TAPER OF 0" TO 3" SHALL BE CONSTRUCTED FROM STATION 0+00 TO STATION 0+50.

THE FOLLOWING RATES HAVE BEEN USED TO CALCULATE PLAN QUANTITIES:

AGGREGATE SHOULDERS TY. B	1.8 T / CU YD
BITUMINOUS CONCRETE	0.0560 T / SQ YD • INCH
AGGREGATE PRIME COAT	0.001 T / SQ YD
BITUMINOUS MATERIAL (PRIME COAT)	0.05 GAL / SQ YD

**SUMMARY OF QUANTITIES**

QUANTITY	UNIT	ITEM	CODE NUMBER
2614.00	FOOT	SHORT-TERM PAVEMENT MARKING REMOVAL	XX003140
145.00	TON	PAVEMENT REMOVAL AND REPLACEMENT (SPECIAL)	XX127400
7150.00	TON	LEVELING BINDER (MACHINE METHOD), SUPERPAVE N70	X4066770
4835.00	TON	BITUMINOUS CONCRETE SURFACE COURSE, SUPERPAVE, MIX "C", NSO	X4066414
3730.00	GALLON	BITUMINOUS MATERIALS (PRIME COAT)	40600100
75.00	TON	AGGREGATE (PRIME COAT)	40600300
61.10	SO YD	BITUMINOUS SURFACE REMOVAL - BUTT JOINT	40600980
10.20	SO YD	TEMPORARY RAMP	40600990
2540.00	TON	AGGREGATE SHOULDERS, TYPE B	48101200
1.0	L SUM	MOBILIZATION	67100100
91,877.00	FOOT	PAINT PAVEMENT MARKING-LINE 4"	78001110 *
7842.00	FOOT	SHORT-TERM PAVEMENT MARKING	70300100
1.00	L SUM	TRAFFIC CONTROL AND PROTECTION, STANDARD 701306	70100460
1.00	L SUM	TRAFFIC CONTROL AND PROTECTION, STANDARD 701336	70100600
327.00	EACH	RAISED REFLECTIVE PAVEMENT MARKER	78100100 *

\* SPECIFICITY ITEMS

**DETAIL OF PRIVATE AND FIELD ENTRANCES**

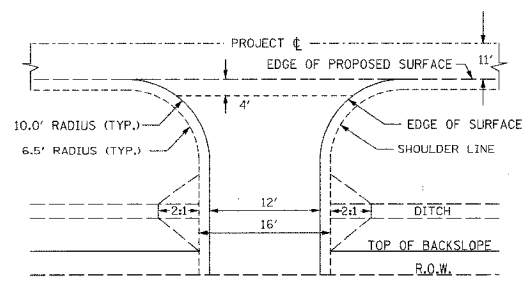

NOTE: THE 4' AREA FROM THE EDGE OF SURFACE, AS SHOWN ABOVE, SHALL BE BITUMINOUS CONCRETE SURFACE COURSE, SUPERPAVE, MIX "C", NSO FOR THE PRIVATE ENTRANCES AND THE FIELD ENTRANCES. THIS QUANTITY IS INCLUDED IN THE QUANTITY FOR BITUMINOUS CONCRETE SURFACE COURSE, SUPERPAVE, MIX "C", NSO.

**PRIVATE & FIELD ENTRANCE APPROACH DETAIL**

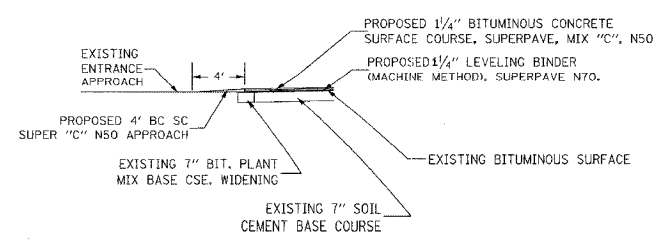

**DETAIL OF PAVEMENT REMOVAL AND REPLACEMENT SPECIAL**

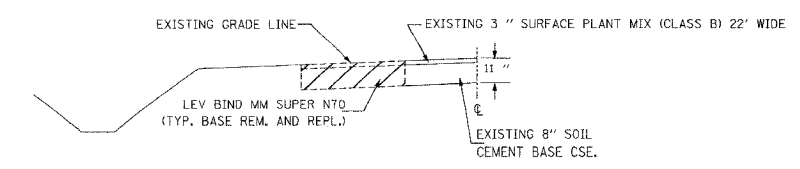

NOTE: IN THE TYPICAL DETAIL ABOVE THE DISTANCE FROM THE CENTERLINE LEFT OR RIGHT AND THE WIDTH OF PAVEMENT REMOVAL AND REPLACEMENT VARIES. SEE SCHEDULE OF PAVEMENT REMOVAL AND REPLACEMENT SPECIAL FOR PROPOSED LOCATIONS.

**AGGREGATE SHOULDER DETAIL**

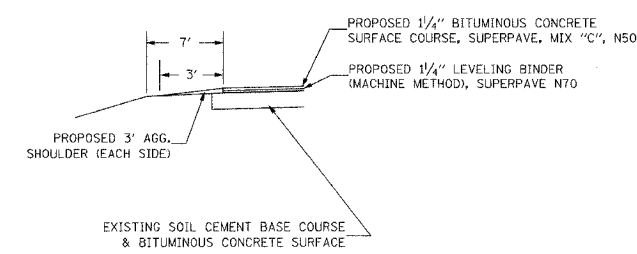

**BUTT JOINT DETAIL**

STA 260+89.8 TO STA 261+39.8

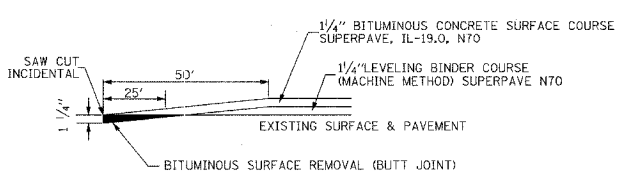

**TEMPORARY RAMP DETAIL**

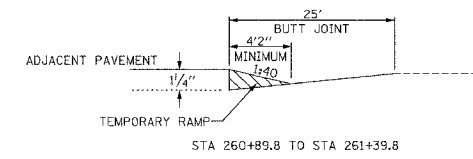

323 W. 3RD ST.  
P.O. BOX 160  
MT. CARMEL, IL  
62863  
PHONE:  
(618)-262-8651  
FAX:  
(618)-263-3327

405 W. STATE ST.  
SUITE 1  
PRINCETON, IN  
47170  
PHONE:  
(812)-386-7611  
FAX:  
(812)-386-2812



PROFESSIONAL DESIGN FIRM  
LAND SURVEY & PROFESSIONAL ENGINEERING CORPORATION  
184-00887  
(62-032435)(35-002768)



DUSTIN K. BUNTING  
NAME  
SIGNATURE  
DATE: 05-09-05  
EXPIRES: 11-30-05

DETAILS OF SURFACING AT INTERSECTIONS AND SIDEROADS

F.A.S.	SECTION	COUNTY	TOTAL SHEETS	SHEET NO.
888	05-00098-00-RS	WHITE	4	3
FDL ROAD DIST. NO. 7		ILLINOIS	HERALD ROAD	
LEC JOB # H08L069WH			CONTRACT NO. 95434	

DETAIL OF INTERSECTION RT. STA. 83+40

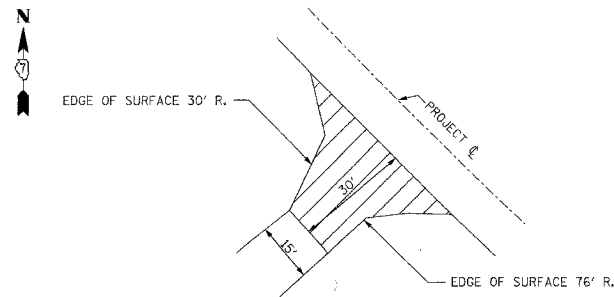

NOTE: THE QUANTITY SHOWN FOR BITUMINOUS CONCRETE SURFACE COURSE, SUPERPAVE, MIX "C", NSO INCLUDES 12.1 TONS OF MATERIAL FOR THE SIDEROAD APPROACH AND RADII.

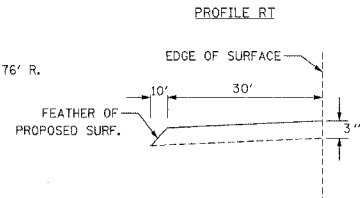

DETAIL OF INTERSECTION LT. STA. 85+40

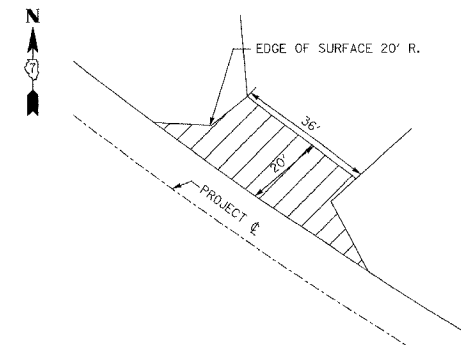

NOTE: THE QUANTITY SHOWN FOR BITUMINOUS CONCRETE SURFACE COURSE, SUPERPAVE, MIX "C", NSO INCLUDES 13.3 TONS OF MATERIAL FOR THE SIDEROAD APPROACH AND RADII.

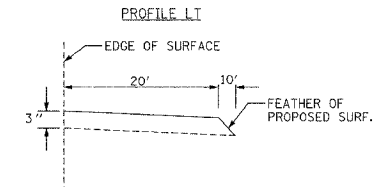

DETAIL OF INTERSECTION LT. STA. 103+91

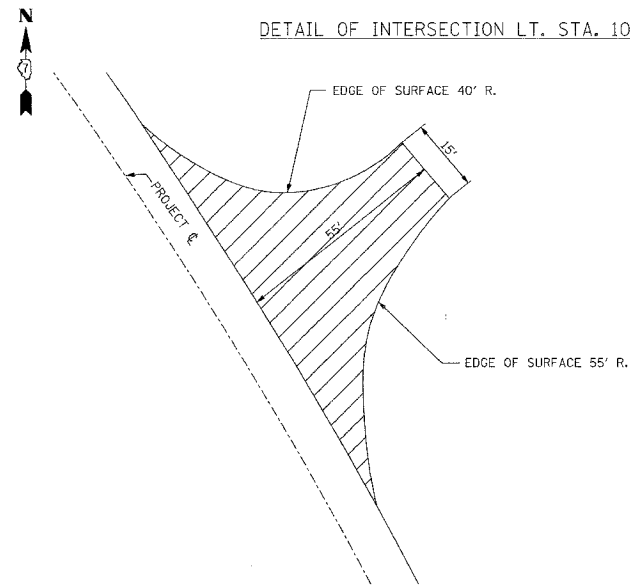

NOTE: THE QUANTITY SHOWN FOR BITUMINOUS CONCRETE SURFACE COURSE, SUPERPAVE, MIX "C", NSO INCLUDES 38.3 TONS OF MATERIAL FOR THE SIDEROAD APPROACH AND RADII.

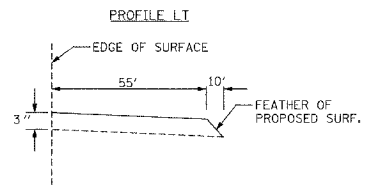

DETAIL OF INTERSECTION RT. STA. 151+52

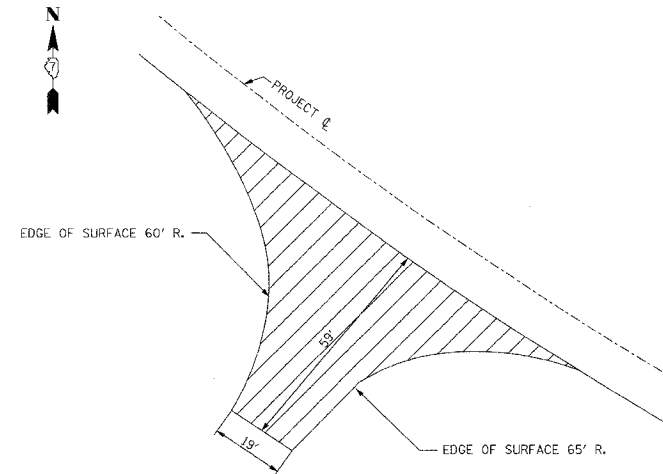

NOTE: THE QUANTITY SHOWN FOR BITUMINOUS CONCRETE SURFACE COURSE, SUPERPAVE, MIX "C", NSO INCLUDES 42.5 TONS OF MATERIAL FOR THE SIDEROAD APPROACH AND RADII.

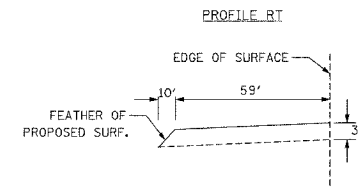

DETAIL OF INTERSECTION LT. STA. 189+80

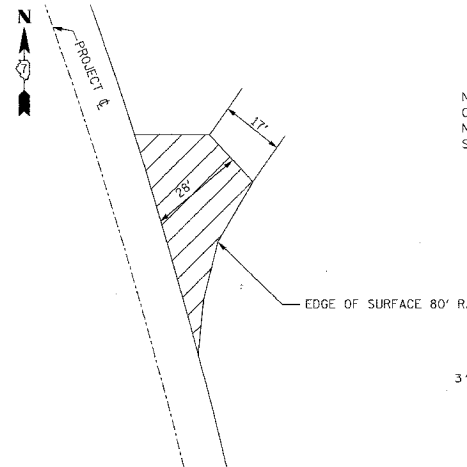

NOTE: THE QUANTITY SHOWN FOR BITUMINOUS CONCRETE SURFACE COURSE, SUPERPAVE, MIX "C", NSO INCLUDES 12.4 TONS OF MATERIAL FOR THE SIDEROAD APPROACH AND RADII.

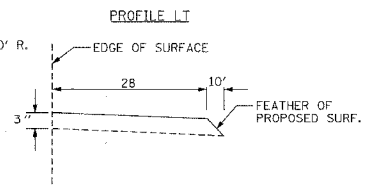

DETAIL OF INTERSECTION RT. STA. 208+22

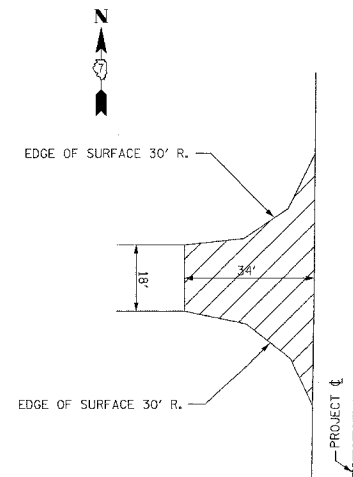

NOTE: THE QUANTITY SHOWN FOR BITUMINOUS CONCRETE SURFACE COURSE, SUPERPAVE, MIX "C", NSO INCLUDES 15.9 TONS OF MATERIAL FOR THE SIDEROAD APPROACH AND RADII.

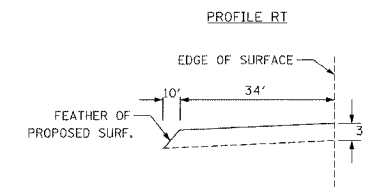

323 W. 3RD ST.  
P.O. BOX 180  
MT. CARMEL, IL  
62893  
PHONE:  
(618)-262-8651  
FAX:  
(618)-263-3327

405 W. STATE ST.  
SUITE 1  
PRINCETON, IN  
47170  
PHONE:  
(812)-386-7611  
FAX:  
(812)-385-2812



PROFESSIONAL DESIGN FIRM  
LAND SURVEY &  
PROFESSIONAL  
ENGINEERING  
CORPORATION  
184-00087  
(62-032438)(35-002769)

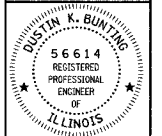

DUSTIN K. BUNTING  
NAME  
*Dustin K. Bunting*  
SIGNATURE  
05-09-05  
DATE  
11-30-05  
EXPIRES

F.A.S.	SECTION	COUNTY	TOTAL SHEETS	SHEET NO.
888	05-0098-00-RS	WHITE	4	4
FED. ROAD DIST. NO. 7		ILLINOIS	HERALD ROAD	
LEC JOB # H08L069WH			CONTRACT NO. 95434	

**SCHEDULE OF PAVEMENT MARKINGS**

STATION	TO	STATION	LOCATION	LENGTH - FOOT
<b>CENTERLINE</b>				
0+00		15+79	CL	395
190+96		261+39.8	CL	1761
<b>EDGE LINE</b>				
0+00		83+18	RT.	8318
83+62		110+35.82	RT.	2674
114+37.9		151+13	RT.	3675
151+93		194+06	RT.	4213
194+00		207+98	RT.	1398
208+46		261+39.8	RT.	5294
<b>EDGE LINE</b>				
0+00		85+12	LT.	8512
85+68		103+63	LT.	1795
104+24		110+35.8	LT.	612
114+37.9		189+67	LT.	7529
190+08		194+06	LT.	398
194+00		261+39.8	LT.	6740
<b>NO PASSING</b>				
0+00		110+35.82	RT.	11036
114+37.9		190+96	RT.	7658
15+79		110+35.82	LT.	9457
114+37.9		199+40	LT.	8508
239+34		253+88	RT.	1454
256+95		261+45	LT.	450
				TOTAL 91,877

THE ABOVE QUANTITY IS SHOW IN THE PAVEMENT MARKING-LINE 4" IN THE SUMMARY OF QUANTITIES.

**SCHEDULE OF AGGREGATE SHOULDER STONE IN TANGENT**

STATION	TO	STATION	LOCATION	ALLOWED TONS EST. QUANTITY
50+00		8+43.26	LT.	46.4
27+35.60		36+34.55	LT	47.2
46+78.97		52+04.80	LT	24.5
60+53.20		63+05.60	LT	11.0
73+41.33		78+35.60	LT	32.6
89+13.68		9528.36	LT	33.2
116+33.33		138+78.76	LT	114.6
160+31.81		173+29.49	LT	72.1
195+00.12		261+39.80	LT	338.8
50+00		8+43.26	RT	36.9
27+35.60		36+34.55	RT	45.9
46+78.97		52+04.80	RT	37.1
60+53.20		63+05.60	RT	18.2
73+41.33		78+35.60	RT	21.5
89+13.68		95+28.36	RT	32.3
116+33.33		138+78.76	RT	128.1
160+31.81		173+29.49	RT	60.4
195+00.12		261+39.80	RT	308.9
				TOTAL 1409.7

THE ABOVE QUANTITY IS FOR THE ENTIRE SECTION AND IS INCLUDED IN THE QUANTITY FOR AGGREGATE SHOULDERS, TYPE B IN THE SUMMARY OF QUANTITIES.

**SCHEDULE OF AGGREGATE SHOULDER STONE IN SUPERELEVATION**

STATION	TO	STATION	LOCATION	ALLOWED TONS EST. QUANTITY
8+43.26		27+35.60	LT.	76.7
36+34.55		46+78.97	LT	43.9
52+04.80		60+53.20	LT	31.8
63+05.60		73+41.33	LT	79.3
78+35.60		89+13.68	LT	82.5
95+28.36		116+33.33	LT	71.3
138+78.76		160+31.81	LT	106.6
173+29.49		195+00.12	LT	91.4
8+43.26		27+35.60	RT.	93.7
36+34.55		46+78.97	RT.	69.0
52+04.80		60+53.20	RT.	36.9
63+05.60		73+41.33	RT.	38.9
78+35.60		89+13.68	RT.	35.6
95+28.36		116+33.33	RT.	94.2
138+78.76		160+31.81	RT.	87.2
173+29.49		195+00.12	RT.	91.4
				TOTAL 1130.4

THE ABOVE QUANTITY IS FOR THE ENTIRE SECTION AND IS INCLUDED IN THE QUANTITY FOR AGGREGATE SHOULDERS, TYPE B IN THE SUMMARY OF QUANTITIES.

**SCHEDULE OF MAILBOX TURNOUTS**

STATION	LOCATION	EST. QUANTITY ALLOWED TONS
3+69	LT.	3.4
5+70	LT.	3.6
7+70	LT.	3.5
11+40	LT.	5.7
12+75	LT.	3.6
27+42	LT.	5.9
31+53	LT.	5.0
37+54	LT.	5.7
42+60	LT.	5.0
59+21	LT.	2.8
63+15	LT.	2.1
106+38	LT.	3.4
109+10	LT.	5.1
120+44	LT.	4.2
125+29	LT.	3.0
126+05	LT.	3.6
137+00	LT.	3.6
173+20	RT.	4.3
206+74	RT.	4.5
252+60	RT.	3.6
254+64	RT.	3.1
258+80	LT.	4.6
		89.3

THE ABOVE QUANTITY IS INCLUDED IN THE BITUMINOUS CONCRETE SURFACE COURSE, SUPERPAVE, MIX "C", N50 IN THE SUMMARY OF QUANTITIES.

**SCHEDULE OF PRIVATE AND FIELD ENTRANCES**

STATION	LOCATION	BC SC SUPER "C" N50 (IN TONS)
0+90	LT.	13.7
0+90	RT.	13.8
2+34	RT.	1.3
3+69	RT.	3.5
5+70	RT.	2.4
7+79	RT.	2.5
10+53	RT.	1.9
11+38	RT.	1.8
12+71	RT.	2.1
12+93	LT.	2.4
13+47	RT.	1.0
24+14	LT.	1.6
24+20	RT.	5.9
27+33	RT.	2.3
27+88	LT.	3.0
29+20	LT.	5.7
29+30	RT.	3.3
31+53	RT.	3.3
37+50	RT.	3.0
42+80	LT.	3.3
42+85	RT.	3.2
45+68	RT.	3.6
48+75	RT.	3.1
51+96	RT.	1.5
53+60	RT.	2.1
59+00	LT.	1.7
63+60	RT.	3.8
68+70	LT.	4.3
71+55	RT.	2.6
75+25	LT.	1.6
77+50	LT.	4.5
79+61	RT.	1.4
87+60	RT.	1.8
89+95	LT.	1.9
90+00	RT.	4.7
106+10	LT.	2.9
107+54	RT.	2.7
109+00	RT.	2.2
115+26	RT.	2.5
117+90	RT.	2.7
119+65	LT.	1.9
120+44	RT.	2.2
125+58	LT.	2.7
126+12	RT.	2.0
130+25	RT.	1.8
136+80	LT.	2.1
138+92	LT.	2.3
155+75	RT.	2.3
160+47	LT.	2.9
163+16	LT.	2.1
173+62	RT.	2.6
173+62	LT.	4.0
192+73	LT.	2.1
203+00	RT.	2.4
206+53	LT.	1.8
208+56	LT.	3.2
208+86	RT.	3.3
221+68	RT.	2.6
221+78	LT.	1.9
233+45	LT.	2.6
245+13	LT.	2.7
252+74	LT.	2.4
254+37	LT.	2.7
255+00	RT.	2.8
259+18	LT.	3.3
259+90	LT.	2.5
		TOTAL 197.8

THE ABOVE QUANTITY IS INCLUDED IN THE BITUMINOUS CONCRETE SURFACE COURSE, SUPERPAVE, MIX "C", N50 IN THE SUMMARY OF QUANTITIES.

**SCHEDULE OF PAV'T REMOVAL AND REPLACEMENT SPECIAL**

STATION	TO	STATION	LOCATION	WIDTH (FEET)	SQ. YD.	TON
24+72		25+45	LT EDGE	5.6	45.4	28.0
138+50		139+18	RT EDGE	3.2	24.2	14.9
153+36		153+64	RT EDGE	4.0	12.4	7.7
198+88		199+93	RT EDGE	4.0	46.7	28.7
201+02		201+50	RT EDGE	3.5	18.7	11.5
239+46		239+70	RT CL	3.0	6.0	4.9
241+28		243+08	RT EDGE	4.0	80.0	49.3
					TOTALS 235.4	145.0

THE SCHEDULE ABOVE REFLECTS APPROXIMATE LOCATION AND ESTIMATED QUANTITIES. THE ACTUAL AREAS SHALL BE LOCATED AND MARKED BY THE ENGINEER PRIOR TO CONSTRUCTION. THE ABOVE QUANTITY IS INCLUDED IN PAVEMENT REMOVAL AND REPLACEMENT SPECIAL IN THE SUMMARY OF QUANTITIES.

329 W. 3RD ST.  
P.O. BOX 160  
MT. CARMEL, IL  
62893  
PHONE: (618)-262-8051  
FAX: (618)-263-3327

405 W. STATE ST.  
SUITE 1  
PRINCETON, IN  
47170  
PHONE: (812)-386-7611  
FAX: (812)-385-2812



PROFESSIONAL DESIGN FIRM  
LAND SURVEY & PROFESSIONAL ENGINEERING CORPORATION  
184-00087  
(62-032435)(35-002789)



JUSTIN K. BUNTING  
NAME  
SIGNATURE  
DATE 05-09-05  
EXPIRES 11-30-05