

LEGEND FOR TYPICAL SECTION

- ① PROPOSED AR401: BITUMINOUS SURFACE COURSE - 4" (2 LIFTS)
 - ② PROPOSED AR603: BITUMINOUS TACK COAT (RATE PER SPECIFICATION)
 - ③ PROPOSED AR602: BITUMINOUS PRIME COAT (RATE PER SPECIFICATION)
 - ④ EXISTING AR401: BITUMINOUS SURFACE COURSE - 4"
 - ⑤ EXISTING AR201: BITUMINOUS BASE COURSE - 2"-3"
 - ⑥ EXISTING AR401: BITUMINOUS SURFACE COURSE - 2"
 - ⑦ EXISTING AR201: BITUMINOUS BASE COURSE - 0"-10" VARIABLE DEPTH
 - ⑧ EXISTING AR401: BITUMINOUS SURFACE COURSE - 4"
 - ⑨ EXISTING AR501: PCC PAVEMENT - 9"
 - ⑩ EXISTING AR208: AGGREGATE SUBBASE COURSE - 8"
 - ⑪ EXISTING GROUND
- BITUMINOUS MILLING [Pattern] - VARIABLE 3" TO 5"

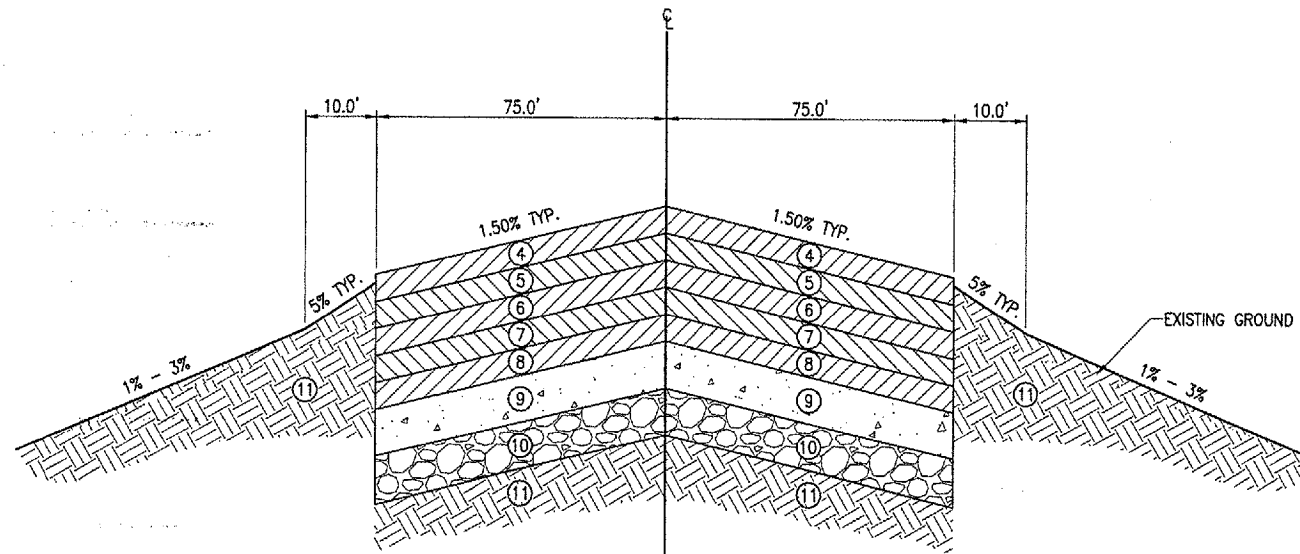

EXISTING RUNWAY PAVEMENT - TYPICAL SECTION

"NOT TO SCALE"

RUNWAY "6/24" STA. 375+50 TO STA. 383+56.20

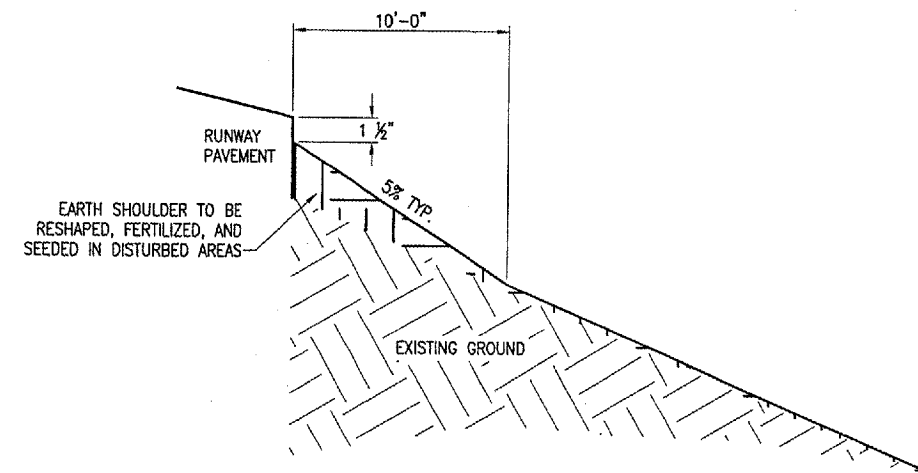

DETAIL 1
EARTH SHOULDER

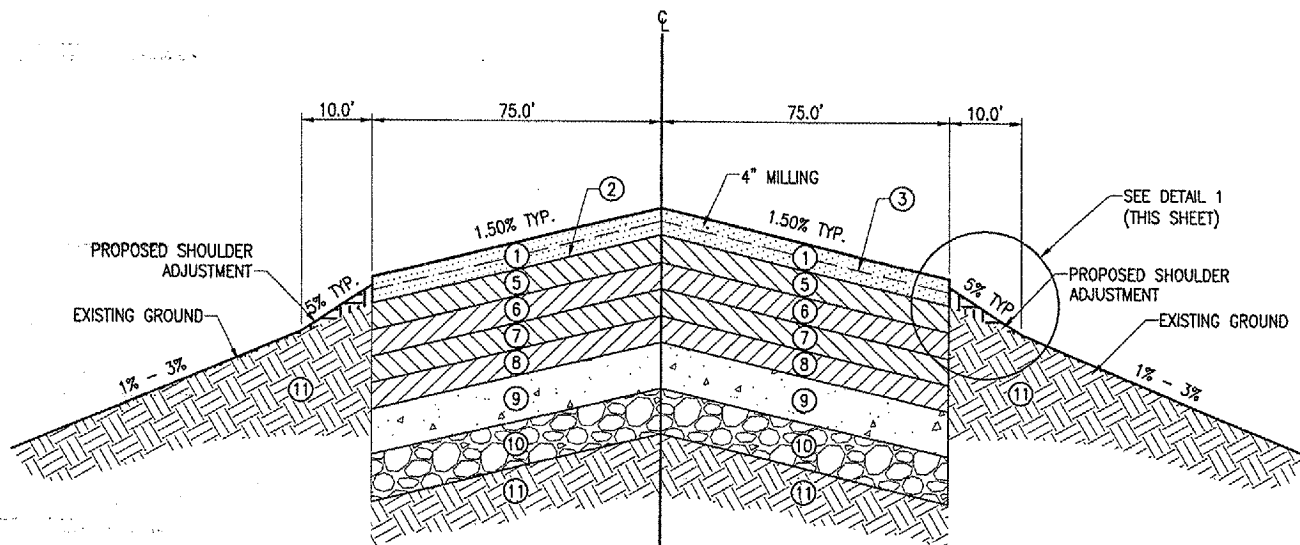

PROPOSED RUNWAY PAVEMENT - TYPICAL SECTION

"NOT TO SCALE"

RUNWAY "6/24" STA. 375+50 TO STA. 383+56.20

NOTE:

THE CONTRACTOR WILL REGRADE, SEED AND FERTILIZE THE DISTURBED EARTH SHOULDER. THE GRADING SHALL SHAPE THE EARTH SHOULDER TO CONFORM TO THE EARTH SHOULDER DETAIL. FERTILIZING AND SEEDING SHALL BE ACCOMPLISHED IN ACCORDANCE TO SPECIFICATION ITEM AR901510.

NO ADDITIONAL PAYMENT FOR THE GRADING AND SEEDING ITEM WILL BE MADE TO THE CONTRACTOR. PAYMENT FOR THE WORK SHALL BE INCLUDED IN THE BID AMOUNT PER TON FOR THE BITUMINOUS SURFACE COURSE.

ANY TURF AREAS DISTURBED BY THE CONTRACTOR WILL BE RESHAPED, FERTILIZED AND SEEDING ACCORDING TO THE ABOVE PARAGRAPH.

BY	REVISION	DATE

A.I.P. PROJ.: 3-17-0033-28
IL. PROJ.: DEC-3414



DECATUR, ILLINOIS

HEI Project No. 802-04TXD	06/07/05
Revision: R-522TYP.DWG	REVIEWED
Scale: N/A	DRAWN
Date: 11/12/04	LAYOUT



Engineers, Architects, Scientists
1525 South Sixth Street
Springfield, Illinois 62703-2888
Offices Nationwide

TAXIWAY G WIDENING
PHASE II

RWY 6-24 RECONSTRUCTION
EXISTING & PROPOSED
TYPICAL SECTIONS

JUN 10, 2005 3:05 PM CCC
I:\AIRPORTS\DECATUR\802-04TXD\AIRPORT\SHEETS\CONTRACT-2\R-522TYP.DWG - Typ. Sections - 6-24