

**FILTER FENCE DETAIL**  
"NOT TO SCALE"

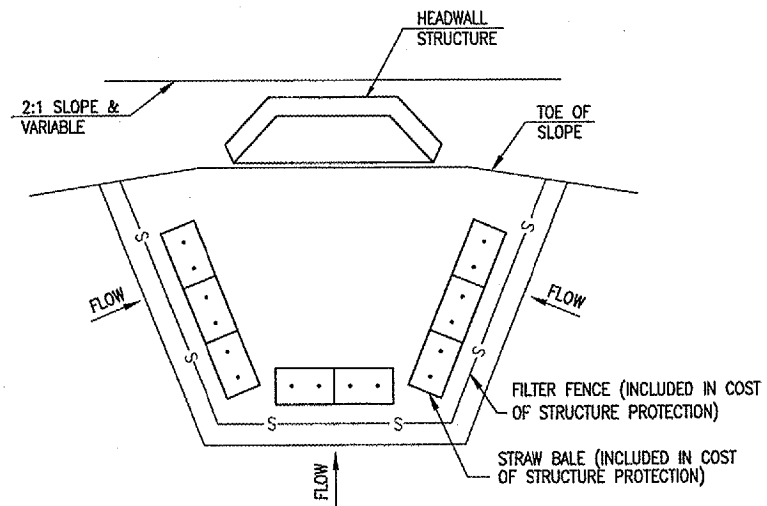

**HEADWALL PROTECTION**  
"NOT TO SCALE"  
CONC. HEADWALL SHOWN. DETAIL SIMILAR FOR FLARED END SECTION.

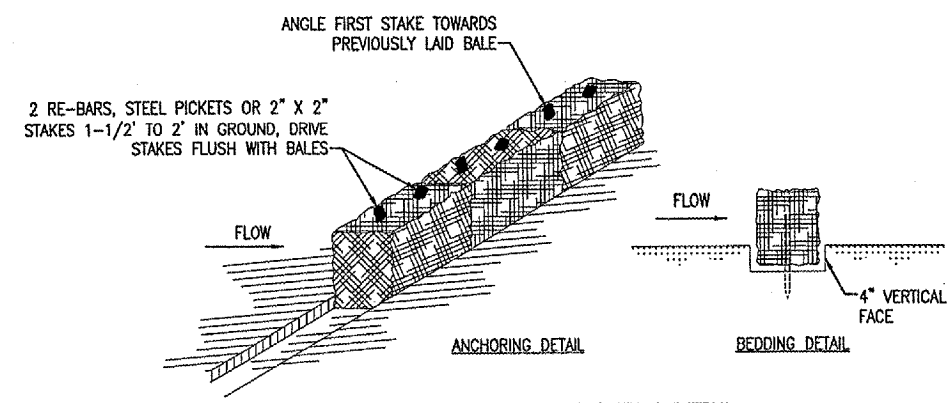

**STRAW BALE DITCH CHECK DETAIL**  
"NOT TO SCALE"

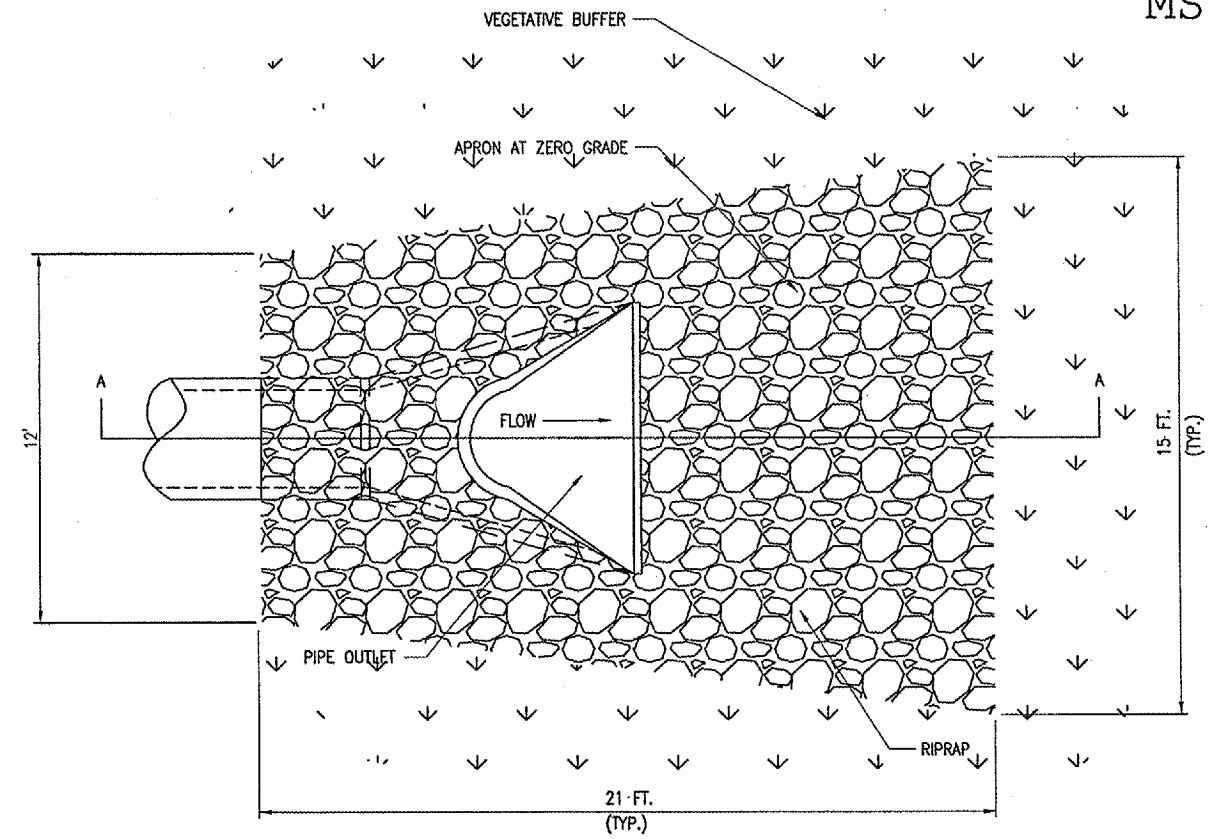

**PIPE OUTLET PROTECTION**  
"NOT TO SCALE"

FLARED END SECTION SHOWN. DIMENSIONS SIMILAR FOR CONCRETE HEADWALL.

**NOTES**

PERMANENT RIPRAP APRONS SHALL BE PLACED AT EACH OF THE DOWNSTREAM END SECTIONS OR HEADWALLS. THE RIPRAP SHALL BE PLACED ON FILTER FABRIC NEATLY AND IN A WORKMANLIKE MANNER CONFORMING TO THE PROPOSED GRADES AND TO THE SATISFACTION OF THE RESIDENT ENGINEER. RIPRAP SHALL BE PAID FOR UNDER ITEM AR156540.

DIMENSIONS OF RIPRAP ARE AS SHOWN UNLESS NOTED OTHERWISE.

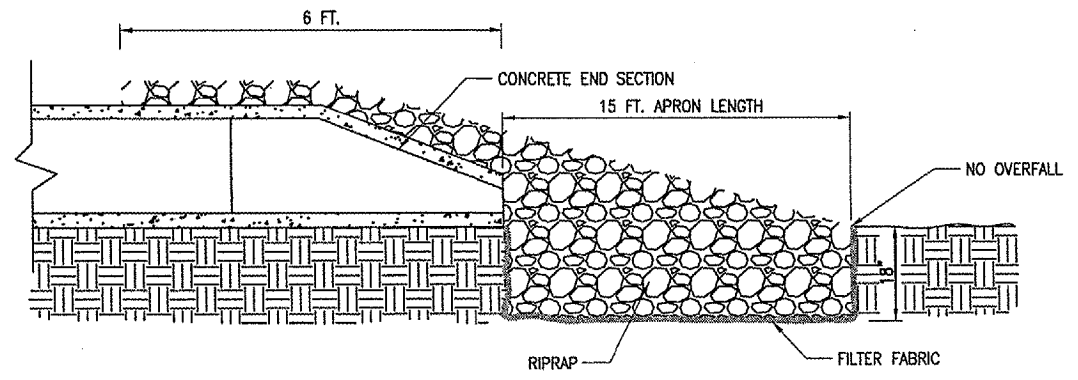

**PIPE OUTLET PROTECTION SECTION A-A**  
"NOT TO SCALE"

REVISION	DATE	BY

MT. STERLING MUNICIPAL AIRPORT  
MT. STERLING, ILLINOIS  
A.I.P. PROJ.: 3-17-0417-B6  
IL PROJ.: 063-3431

HEI Project No. 818-05TX	
Estimate R-531SWP	
Scale NOT TO SCALE	
Date 04/28/05	
LAYOUT JFO 03/14/05	
DRAWN JFO 03/21/05	
REVIEWED CAH 05/17/05	

**HANSON**  
Hanson Professional Services Inc.  
1925 South Sixth Street  
Springfield, Illinois 62703-2886  
Offices Nationwide

PARALLEL TAXIWAY TAXIWAY "B"  
PROPOSED EROSION CONTROL DETAILS

07/13/2005 03:06 PM Bek

I:\Airports\MtSterling\818-05TX\Airport\Sheets\R-104ECP.dgn