

EXISTING TYPICAL SECTION
WOLF RD.

STATION:
26+00 TO 33+50
56+00 TO 72+08

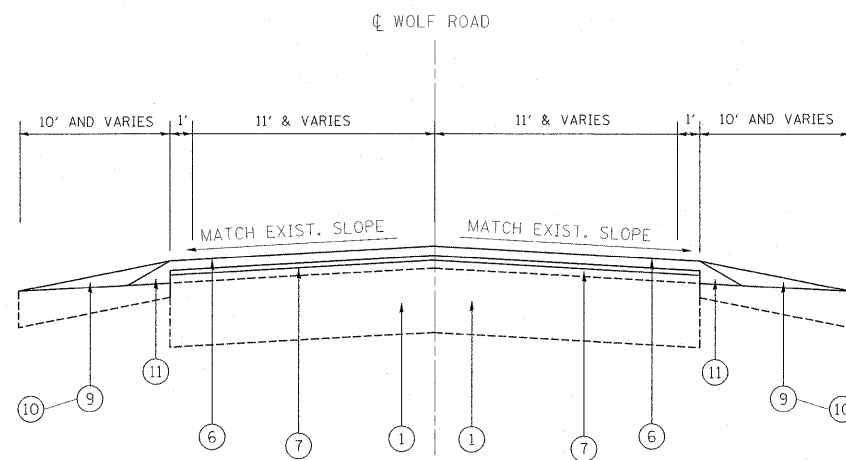

PROPOSED TYPICAL SECTION
WOLF RD.

STATION:
26+00 TO 33+50
56+00 TO 72+08

LEGEND

- ① EXIST. PCC BASE COURSE, 9''(±)
- ② EXIST. HOT-MIX ASPHALT SURFACE COURSE (BEFORE MILLING), 4 1/4''(±)
- ③ EXIST. CONCRETE CURB AND GUTTER
- ④ EXIST. AGGREGATE SHOULDER
- ⑤ PROP. HOT-MIX ASPHALT SURFACE REMOVAL - 2 1/4''
- ⑥ PROP. HOT-MIX ASPHALT SURFACE COURSE, MIX "D", N70, 1 1/2''
- ⑦ PROP. POLYMERIZED LEVELING BINDER (MM), IL-4.75, N50, 3/4''
- ⑧ PROP. CONCRETE CURB AND GUTTER REMOVAL AND REPLACEMENT (LOCATIONS TO BE DETERMINED BY THE RESIDENT ENGINEER)
- ⑨ PROP. GRADING AND SHAPING SHOULDERS
- ⑩ PROP. AGGREGATE WEDGE SHOULDER, TYPE B
- ⑪ SAFETY EDGE

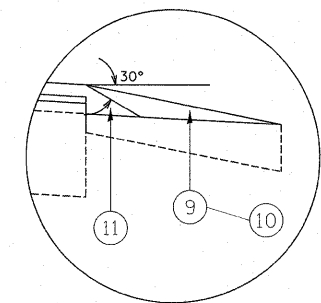

SAFETY EDGE DETAIL
NTS

FILE NAME = c:\px_work\pwido1\beskinm\0246754\018511-sh-t-pi-andgn	USER NAME = beskinm	DESIGNED -	REVISED -	STATE OF ILLINOIS DEPARTMENT OF TRANSPORTATION	WOLF ROAD (FRANKLIN ST. TO GRAND AVE.) EXISTING AND PROPOSED TYPICAL SECTIONS	F.A.U. RTE.	SECTION	COUNTY	TOTAL SHEETS	SHEET NO.
	PLOT SCALE = 50.0000' / IN.	CHECKED -	REVISED -			2690	2527 RS-2	COOK	22	5
	PLOT DATE = 5/17/2011	DATE -	REVISED -			CONTRACT NO. 60M29				