

EXISTING TYPICAL SECTION
IL 38 EXIT RAMP TO IL 56
ALL RAMPS FOR IL 38 AT YORK RD.
RAMP 'N'

** EXISTING SHOULDERS LOW AT IL 38 AT YORK RAMPS. CONTRACTOR SHALL LEVEL EXISTING SHOULDERS TO TOP OF EXISTING ADJACENT CONCRETE RAMP PRIOR TO RESURFACING. THIS RESURFACING WILL BE PAID FOR AT THE CONTRACT UNIT PRICE PER TON FOR "HOT MIX ASPHALT BINDER COURSE, IL-19.0, N70".

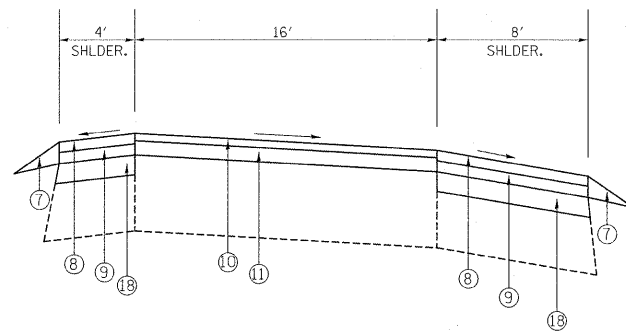

PROPOSED TYPICAL SECTION
IL 38 EXIT RAMP TO IL 56
ALL RAMPS FOR IL 38 AT YORK RD.
RAMP 'N'

LEGEND:

- ① EXISTING AGGREGATE SHOULDER TYP. B
- ② EXISTING HMA SHOULDER, (VARIABLE DEPTH)
- ③ EXISTING JOINTED REINFORCED PC CONCRETE PAVEMENT, 10"
- ④ EXISTING CURB & GUTTER B 6.12
- ⑤ EXISTING CURB & GUTTER B 6.24
- ⑥ EXISTING CURB & GUTTER M 2.24
- ⑦ PROPOSED AGGREGATE WEDGE SHOULDER, TYPE B
- ⑧ PROPOSED HOT-MIX ASPHALT SURFACE COURSE, MIX "D", N70, (IL 9.5 mm); 1 1/2" (SHOULDER/GORE/ HMA RAMP SECTION)
- ⑨ PROPOSED HOT-MIX ASPHALT BINDER COURSE, IL-19.0, N70; 2 1/2" (SHOULDER)
- ⑩ PROPOSED POLYMERIZED HOT-MIX ASPHALT SURFACE COURSE, MIX "F", N90 1 3/4" (RAMP)
- ⑪ PROPOSED POLYMERIZED HOT-MIX ASPHALT BINDER COURSE, IL-19.0, N90; 2 1/4" (RAMP)
- ⑫ PROPOSED PCC SURFACE REMOVAL (VAR. DEPTH), PER STD. BD-33
- ⑬ PROPOSED PARTIAL DEPTH REMOVAL, 3"
- ⑭ PROPOSED HOT-MIX ASPHALT SURFACE REMOVAL, 2 1/4" (GORE/HMA RAMP SECTION)
- ⑮ PROPOSED HOT-MIX ASPHALT SURFACE REMOVAL, VAR. DEPTH (0 TO 2 1/4") (GORE)
- ⑯ PROPOSED LEVELING BINDER (MACHINE METHOD), N70, 3/4" (GORE/HMA RAMP SECTION)
- ⑰ PROPOSED PARTIAL DEPTH PATCH, (HOT-MIX ASPHALT SURFACE COURSE, MIX "D", N70, (IL 9.5 mm); 3")
- ⑱ PROPOSED HOT-MIX ASPHALT BINDER COURSE, IL-19.0, N70; ±5"
- ⑲ PROPOSED STRIP REFLECTIVE CRACK CONTROL TREATMENT

FILE NAME =	USER NAME = abreuh	DESIGNED -	REVISED -	STATE OF ILLINOIS DEPARTMENT OF TRANSPORTATION	VARIOUS AT VARIOUS DUPAGE COUNTY LOCATIONS TYPICAL SECTIONS				F.A. RTE.	SECTION	COUNTY	TOTAL SHEETS	SHEET NO.		
ct:\pw_work\pwt\dot\obreuh\d0265704\015111-ah-t-plan.dgn		DRAWN -	REVISED -		SCALE:	SHEET NO.	OF	SHEETS	STA.	TO STA.	VAR.	2011-030-I	DUPAGE	33	8
		CHECKED -	REVISED -												
		DATE -	REVISED -												
	PLOT SCALE = 50.0000' / IN.														
	PLOT DATE = 5/23/2011														
											CONTRACT NO. 60P34			ILLINOIS FED. AID PROJECT	