

PROPOSED EMERGENCY VEHICLE PREEMPTORS		
EMERGENCY VEHICLE PREEMPTOR	3	4
MOVEMENT	← →	↓

- LEGEND**
- ← ○ → DUAL ENTRY PHASE
  - ← ○ → PEDESTRIAN PHASE
  - ◊ OL OVERLAP
  - NUMBER REFERS TO ASSOCIATED PHASE

- NOTES:**
1. ALL PEDESTRIAN SIGNAL HEADS SHALL BE BAGGED AND DISCONNECTED AT LOCATIONS WHERE EXISTING PAVEMENT IS REMOVED. ALL PEDESTRIAN SIGNAL HEADS SHALL REMAIN BAGGED UNTIL THE PAVEMENT IS RESTORED TO PROVIDE A SAFE CROSSING AREA. USAGE OF PEDESTRIAN SIGNAL HEADS IS BASED ON CONSTRUCTION STAGING AND SHALL BE DETERMINED BY THE RESIDENT ENGINEER. IF SIDEWALKS AND PED CROSSINGS ARE NOT PROVIDED, THE PEDESTRIAN SIGNAL EQUIPMENT SHALL REMAIN DISCONNECTED UNTIL WARRANTED PRIOR TO PERMANENT SIGNAL TURN-ON.
  2. WALKUP AVENUE SOUTH OF IL ROUTE 176 SHALL BE CLOSED TO TRAFFIC DURING STAGE 1.
  3. THE NORTHBOUND SIGNAL HEADS SHALL BE COVERED AND THE DETECTION SHALL BE DISCONNECTED DURING STAGE 1.
  4. THE WESTBOUND LEFT TURN SIGNAL SECTIONS SHALL BE COVERED AND DISCONNECTED AND DETECTION SHALL BE DISCONNECTED DURING STAGE 1.
  5. THE SOUTHBOUND GREEN AND YELLOW LEFT TURN SIGNAL SECTIONS SHALL BE COVERED AND DISCONNECTED AND THE SOUTHBOUND LEFT LANE DETECTOR SHALL PLACE CALLS INTO PHASE 4 DURING STAGE 1.

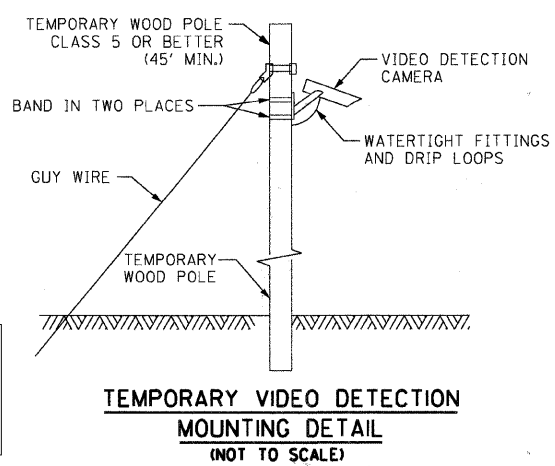

TRAFFIC SIGNAL INSTALLATION ELECTRICAL SERVICE REQUIREMENTS					TOTAL WATTAGE
TYPE	NO. OF LAMPS X INCAND.	LED X	% OPERATION		
SIGNAL (RED)	13	X	17	0.50	110.50
(YELLOW)	13	X	25	0.25	81.25
(GREEN)	13	X	15	0.25	48.75
ARROW	8	X	12	0.10	9.60
PED. SIGNAL	8	X	25	1.00	200.0
CONTROLLER	1	X	100	1.00	100.0
ILLUM. SIGN	--	X		0.05	
VIDEO SYSTEM		150		1.00	150.0
ENERGY COSTS TO: CITY OF CRYSTAL LAKE				TOTAL =	700.1
MARK STONIKAS (815) 356-3700, EXT. 4025					
100 W. WOODSTOCK STREET					
CRYSTAL LAKE, ILLINOIS 60014					
ENERGY SUPPLY: CONTACT: LISA COOK					
PHONE: 815-477-5204					
COMPANY: COM. ED.					

RESTORATION OF WORK AREA. RESTORATION OF THE TRAFFIC SIGNAL WORK AREA SHALL BE INCIDENTAL TO THE RELATED PAY ITEM SUCH AS FOUNDATION, CONDUIT, HANDHOLE, TRENCH AND BACKFILL, ETC., AND NO EXTRA COMPENSATION SHALL BE ALLOWED. ALL ROADWAY SURFACES SUCH AS SHOULDERS, MEDIANS, SIDEWALKS, PAVEMENT, ETC. SHALL BE REPLACED IN KIND. ALL DAMAGE TO MOWED LAWNS SHALL BE REPLACED WITH AN APPROVED SOD, AND ALL DAMAGE TO UNMOWED FIELDS SHALL BE SEEDED IN ACCORDANCE WITH STANDARD SPECIFICATIONS 252 AND 250 RESPECTIVELY.

REVISIONS	
NAME	DATE

MCHENRY COUNTY DIVISION OF TRANSPORTATION  
WALKUP ROAD F.A.U. 0085

**STAGE 1: TEMP CABLE PLAN, PHASE DESIGNATION DIAGRAM, EMERGENCY VEHICLE SEQUENCE**  
IL ROUTE 176 & WALKUP ROAD

SCALE: N.T.S. DRAWN BY: SNB  
DATE: 06/10/11 CHECKED BY: RRM

**TENG**  
TENG & ASSOCIATES, INC.  
ENGINEERS/ARCHITECTS/PLANNERS  
200 N. MICHIGAN AVE. CHICAGO, IL 60611  
TELEPHONE: 312.666-6600

11/5-0944/AVVAULT.D-TRANS-01/2202/300-03/CIVIL/CAD/02 CONTRACT VIA TEMP SHEET TPO2010/LSHT STANKIRJ  
 6-09-2011 16:38:48  
 1 2 3 4 5 6 7 8 9 10 11 12 13 14 15 16 17 18 19 20 21 22 23 24 25 26 27 28 29 30 31 32 33 34 35 36 37 38 39 40 41 42 43 44 45 46 47 48 49 50 51 52 53 54 55 56 57 58 59 60 61 62 63