

DRILL & GROUT  
3 - #4 BARS  
EVENLY SPACED  
INTO EXISTING  
CURB & GUTTER

NOTE:  
THIS WORK WILL NOT BE PAID  
FOR SEPARATELY, BUT SHALL BE  
INCLUDED IN THE COST OF THE  
PROPOSED B-6.12 CURB & GUTTER.

**DETAILS TO TIE EXISTING CURB & GUTTER  
TO PROPOSED CURB & GUTTER**

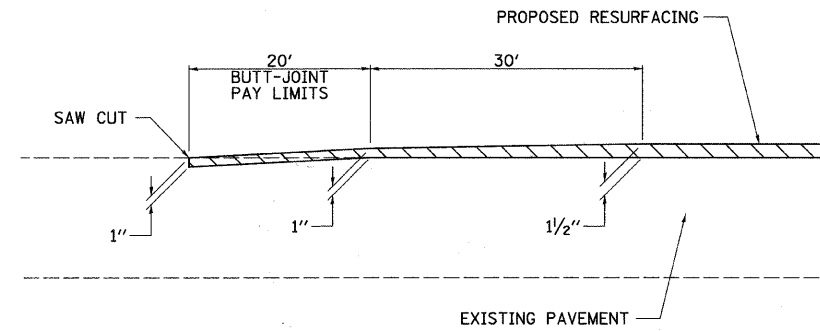

**BUTT JOINT DETAIL  
(SIDE ROADS)**

LINDEN ST. (SOUTH & NORTH LEGS)  
ALABAMA AVE.  
WALKER AVE.  
CLARENDON HILLS RD.  
PROSPECT AVE.

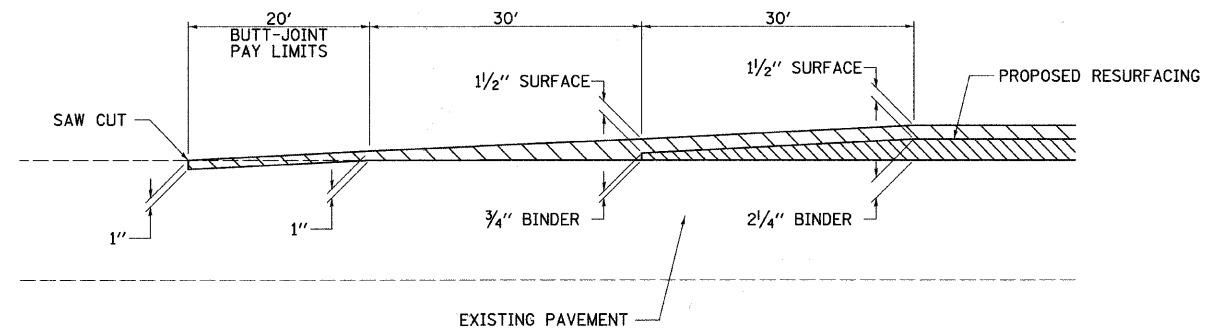

**BUTT JOINT DETAIL**

C.H. 35 (55TH ST.)  
CASS AVE. (SOUTH & NORTH LEGS)

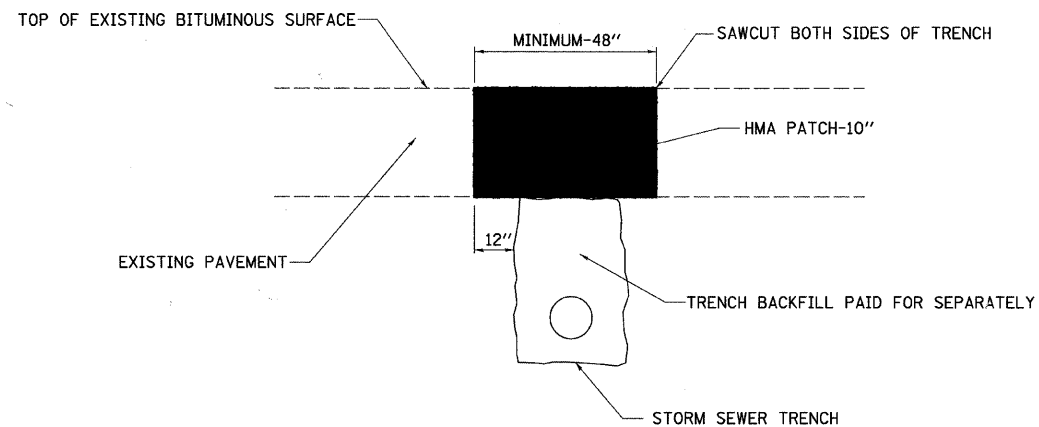

NOTE:  
THE WIDTH OF THE FULL DEPTH PATCH OVER A TRENCH  
SHALL BE 12 INCHES WIDER ON EACH SIDE OF THE TRENCH.

**PAVEMENT REMOVAL AND HOT MIX ASPHALT REPLACEMENT DETAIL**

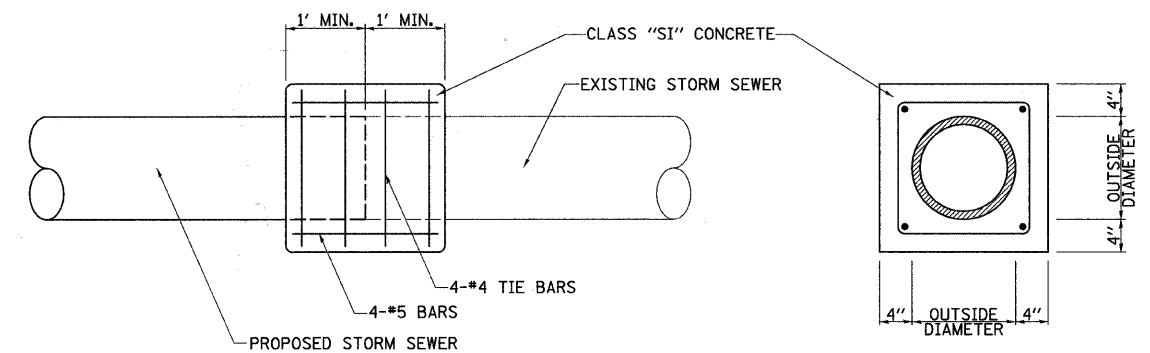

| CONCRETE COLLAR       |        |      |      |  |
|-----------------------|--------|------|------|--|
| STATION               | OFFSET | SIDE | EACH |  |
| CASS AVE. (SOUTH LEG) |        |      |      |  |
| 195+61.80             | 21.7   | LT   | 1    |  |
| 197+48.50             | 23.1   | RT   | 1    |  |

NOTE:  
COST OF CONCRETE COLLAR SHALL BE  
INCIDENTAL TO PROPOSED PIPE.

**CONCRETE COLLAR DETAIL**

|                                     |                     |            |           |
|-------------------------------------|---------------------|------------|-----------|
| FILE NAME =<br>v:\2791\2791h002.dgn | USER NAME = shughes | DESIGNED - | REVISED - |
|                                     |                     | DRAWN -    | REVISED - |
|                                     |                     | CHECKED -  | REVISED - |
|                                     |                     | DATE -     | REVISED - |
|                                     |                     |            |           |

**STATE OF ILLINOIS  
DEPARTMENT OF TRANSPORTATION**

**C.H. 35 (55TH ST.) CONSTRUCTION DETAILS**

SCALE: N/A SHEET NO. 1 OF 4 SHEETS STA. N/A TO STA. N/A

|                           |                |        |                    |              |
|---------------------------|----------------|--------|--------------------|--------------|
| F.A.U.<br>RTE.            | SECTION        | COUNTY | TOTAL<br>SHEETS    | SHEET<br>NO. |
| 1504                      | 94-00302-00-FP |        | 240                | 140          |
|                           |                |        | CONTRACT NO. 63609 |              |
| ILLINOIS FED. AID PROJECT |                |        |                    |              |