

SECTION	COUNTY	TOTAL SHEETS
110X-75B	SANGAMON	25
NO. 1		9

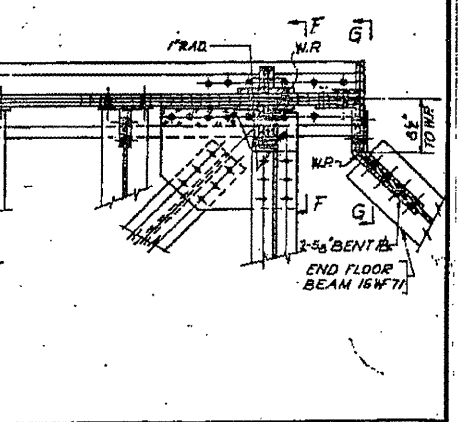
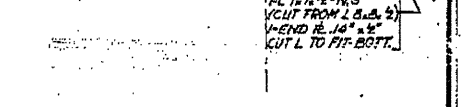
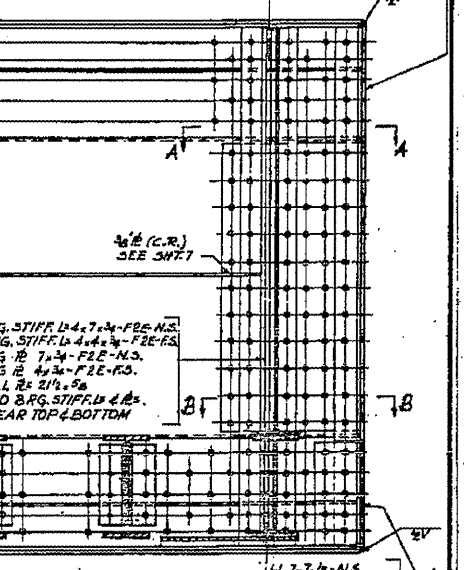
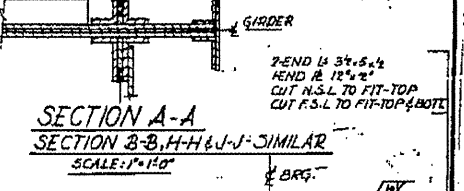

GIRDER DETAILS			
UNDERPASS			
1.T.R.	BRIDGE No. F-71.5		
OVER SOUTH 5 TH STREET EXTENDED SPRINGFIELD, ILLINOIS			
PROJECT UG (6640)			
F.A. ROUTE 5	SECTION 110X-75B		
SANGAMON COUNTY			
STATION 8+22.70			

ALFRED BENESCH & ASSOCIATES
CONSULTING ENGINEERS
10 E. WABASH AVE. CHICAGO, ILLINOIS

FILE NAME	USER NAME	DESIGNED	REVISED
#FILE#	#USER#	DRAWN	REVISED
		CHECKED	REVISED
		DATE	REVISED

STATE OF ILLINOIS
DEPARTMENT OF TRANSPORTATION

084-0033 (FOR INFORMATION ONLY)	SCALE:	SHEET NO. OF SHEETS	STA. TO STA.
---------------------------------	--------	---------------------	--------------

F.A.P. RTE.	SECTION	COUNTY	TOTAL SHEETS
666	D-6 PAINTING 2000-	SANGAMON	13
	2012	CONTRACT NO. T2048	
FED. ROAD DIST. NO. 6 ILLINOIS FED. AID PROJECT			