

Place standard end shoe between splice plate and rail element

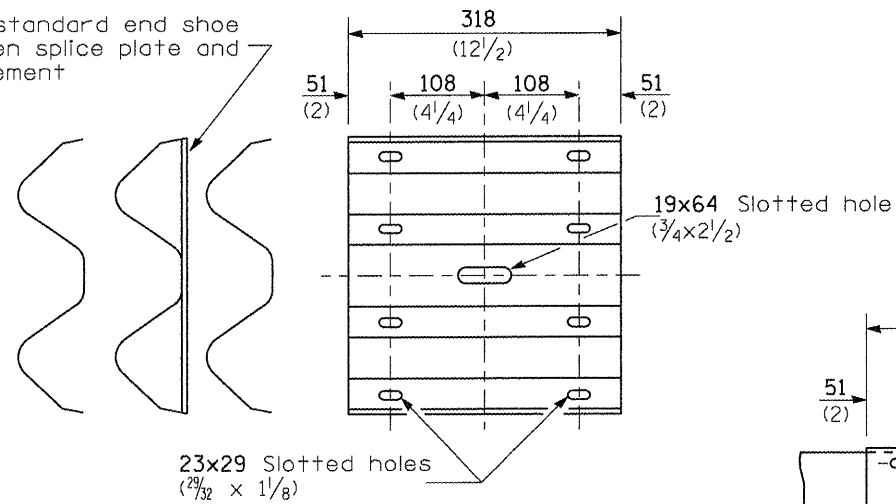

23x29 Slotted holes
($\frac{29}{32} \times 1\frac{1}{8}$)

SPLICE PLATE

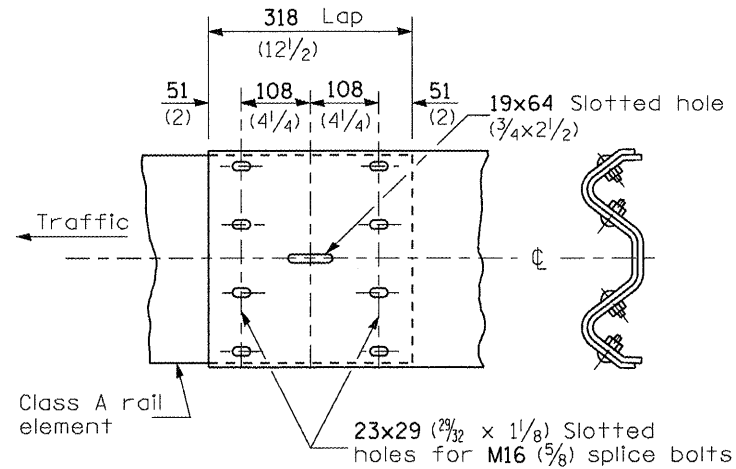

RAIL ELEMENT SPLICE

23x76 ($\frac{23}{32} \times 3$) Slots for splice bolts with std. galv. washer placed under locknut

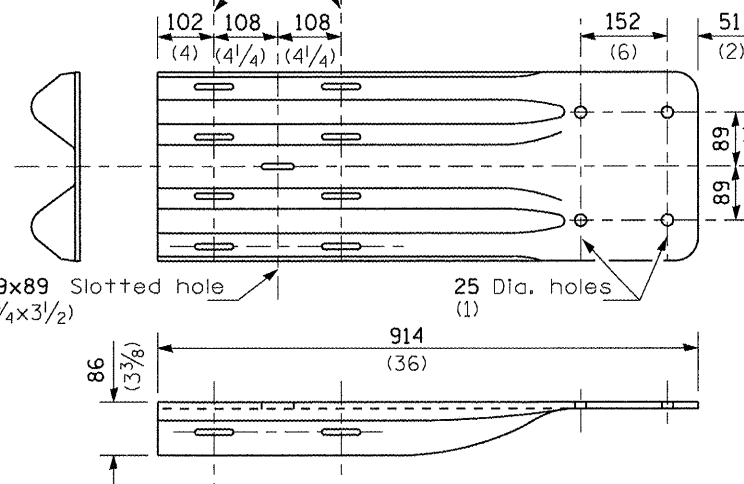

NOTE

When end shoe is attached to a bridge parapet which has an expansion joint, the bolts shall be provided with a locknut or double nut and shall be tightened only to a point that will allow guardrail movement.

The standard end shoe shall be attached to the concrete with pre-drilled or self-drilling anchor bolts. The anchor cone shall be set flush with the surface of the concrete.

Externally threaded studs protruding from the surface of the concrete will not be permitted.

END SHOE

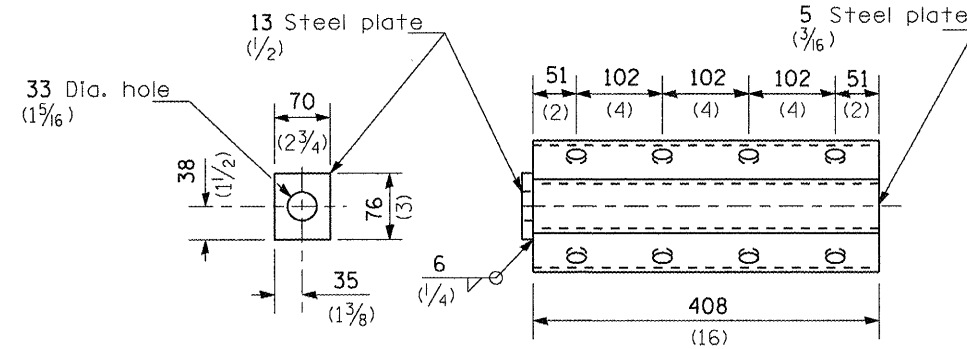

NOTE

Anchor plate T shall be used to attach cable assembly to guardrail when required on traffic barrier terminals.

ANCHOR PLATE T DETAILS

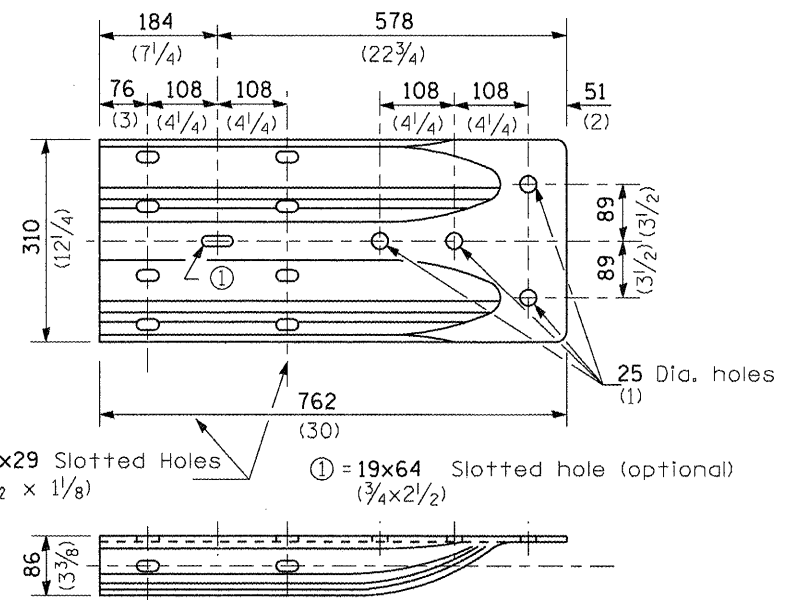

ALTERNATE END SHOE

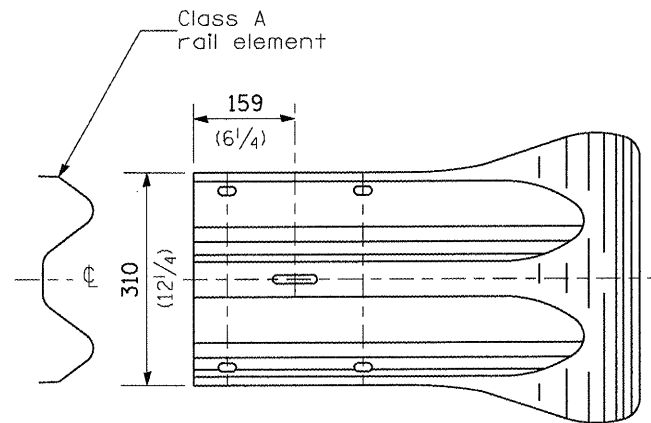
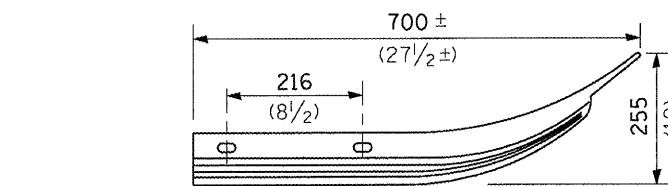

END SECTION

FILE NAME =	USER NAME = Sparksgr	DESIGNED -	REVISED -	STATE OF ILLINOIS DEPARTMENT OF TRANSPORTATION	PRE-MGS HIGHWAY STANDARD 630001-06 STEEL PLATE BEAM GUARDRAIL EFFECTIVE 4-1-06	F.A. RTE.	SECTION	COUNTY	TOTAL SHEETS	SHEET NO.
c:\pwork\pwork\sparksgr\d0262291\067239-sh1-207-630001-06_SteelPlateBeamGuardrail	DRAWN -	REVISED -	VAR				VAR	18	9	
PLDT SCALE = 0:26.000 ms / in.	CHECKED -	REVISED -								
PLDT DATE = Apr-01-2011 09:43:53AM	DATE -	REVISED -								
					SCALE:	SHEET NO.	OF SHEETS	STA.	TO STA.	(SHEET 3 OF 4)
								CONTRACT NO. 72E39		