

NOTE:  
WHEN MILLING OPERATIONS PRODUCE A ROUNDED EDGE,  
THEN A SAW CUT SHALL BE USED TO MANUFACTURE  
A PERPENDICULAR EDGE AS SHOWN IN THE DETAIL.  
THE ENGINEER SHALL BE THE SOLE JUDGE  
CONCERNING THE USE OF THIS DETAIL

### HMA DETAIL AT BUTT JOINTS

406-8

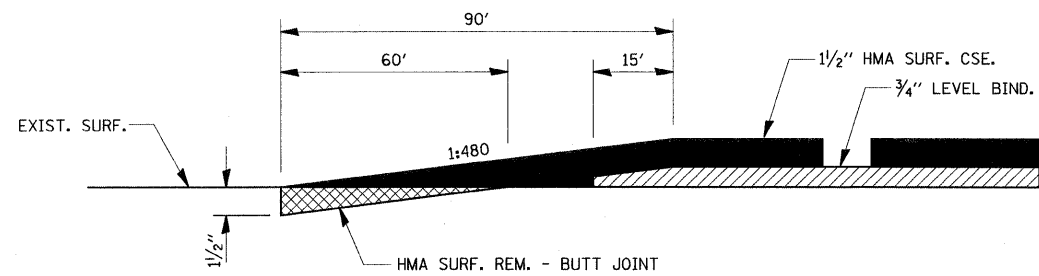

406-9

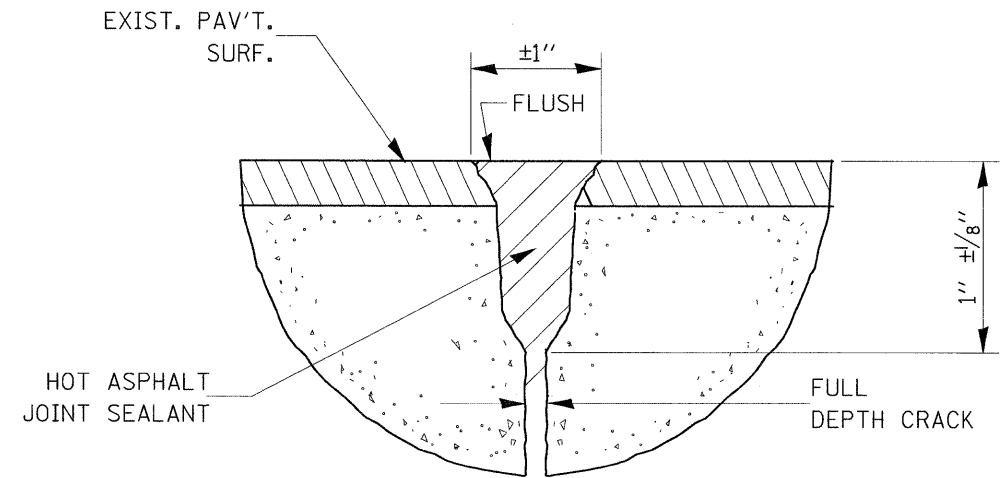

### SEALING CRACKS (PAVEMENT) DETAIL

NOTE: ALL CRACKS LESS THAN 3/8" WIDTH REQUIRE ROUTING

451-1

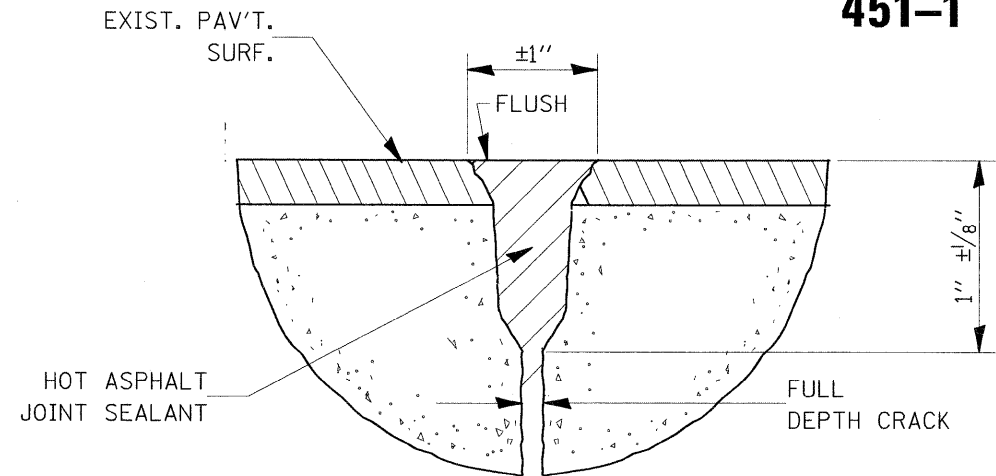

### ROUTING & SEALING JOINTS

(CENTERLINE & TRANSVERSE PATCH BOUNDARIES)

420-3

JAN 2001 406-8, 406-9, 406-10, 406-11, 440-2  
 JAN 2002 406-8, 406-9, 406-10, 406-11, 440-2  
 420-3, 422-1, 451-1, 451-2

FILE NAME =	USER NAME = #USER#	DESIGNED -	REVISED -	<b>STATE OF ILLINOIS DEPARTMENT OF TRANSPORTATION</b>	<b>DISTRICT 3 STANDARDS NORTH FIRST STREET</b>			F.A. RTE.	SECTION	COUNTY	TOTAL SHEETS	SHEET NO.
P:\2011\110113\oad\phase 2\dwg\110113 - Sht - State Standards.dgn		DRAWN -	REVISED -					5352	09-00176-01-RS	DeKALB	15	12
PLOT SCALE = #SCALE#		CHECKED -	REVISED -		SCALE: SHEET NO. OF SHEETS STA. TO STA.			CONTRACT NO. 87-492				
PLOT DATE = 5/24/2011		DATE -	REVISED -		ILLINOIS FED. AID PROJECT							