

ROUTE	SECTION	COUNTY	TOTAL SHEETS	SHEET NO
TR 23	09-01181-00-BR	PULASKI	13	7
PROJECT NO. BROS-153(31)			CONTRACT NO. 99421	

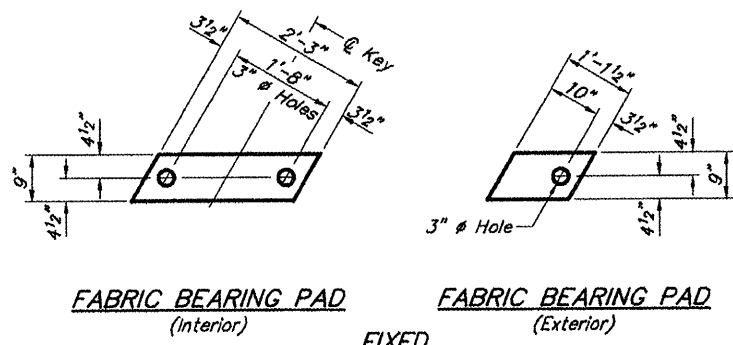

FABRIC BEARING PAD (Interior)
FABRIC BEARING PAD (Exterior)

FIXED

Note: Omit holes when using expansion bearings.

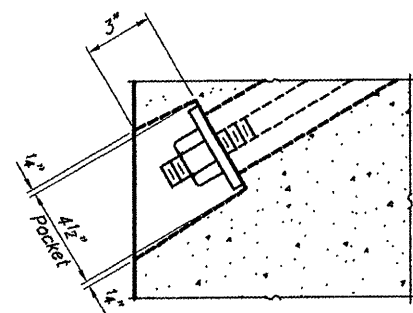

SECTION A-A

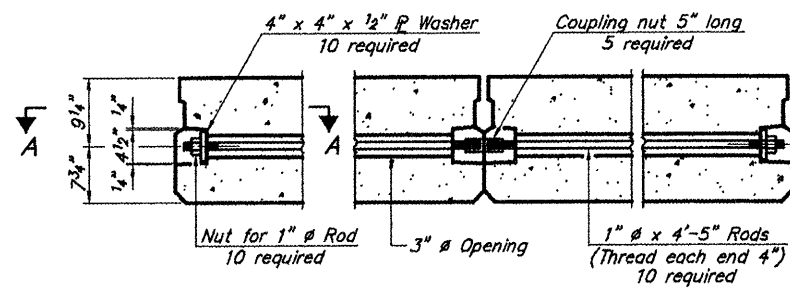

TYPICAL TRANSVERSE TIE ASSEMBLY

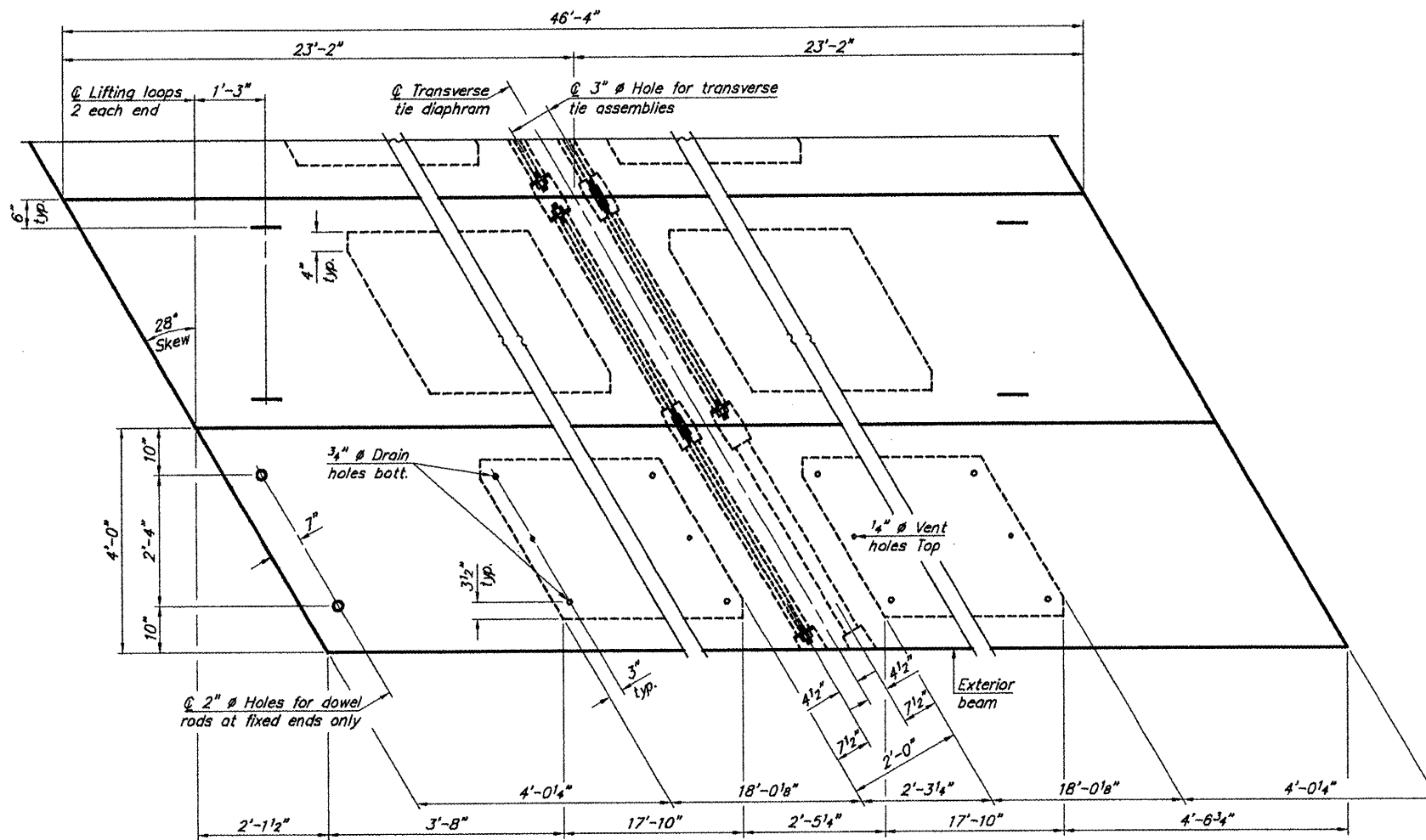

PLAN VIEW

Note: Connect beams in pairs with the transverse tie configuration shown.

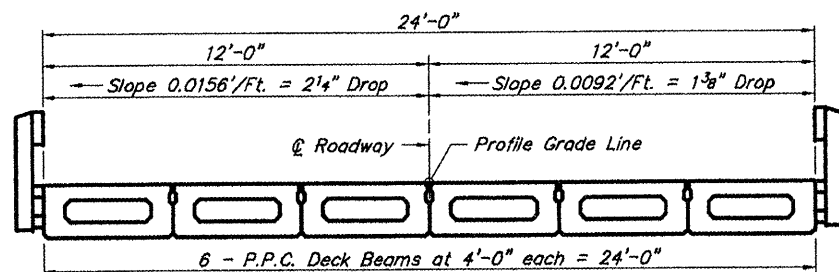

CROSS SECTION

NOTES

Prestressing steel shall be uncoated high strength, low relaxation 7-wire strand, Grade 270. The nominal diameter shall be 1/2" and the nominal cross-sectional area shall be 0.153 sq. in. The 1" rods in the transverse tie assembly shall be tightened to a snug fit and the threads set. Pockets on exterior faces of bridge shall be filled with grout after transverse tie assembly is in place.
Reinforcement bars shall conform to ASTM A 706, Grade 60. (See Special Provisions).
Two 1/8" fabric adjusting shims of the dimensions of the exterior bearing pad shall be provided for each bearing pad location.
A minimum 2 1/2" lifting pin shall be used to engage the lifting loops during handling.
Corrosion inhibitor, per Article 1020.05(b)(12) and 1021.06 of the Standard Specifications, shall be used in the concrete for precast prestressed concrete deck beams.
Compressive strength of prestressed concrete, f_c, shall be 6000 psi.
Compressive strength of prestressed concrete at release, f_{ci}, shall be 5000 psi.

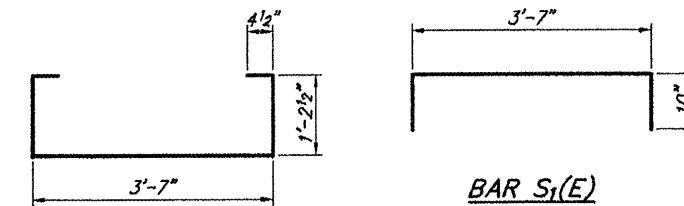

BAR S₁(E)

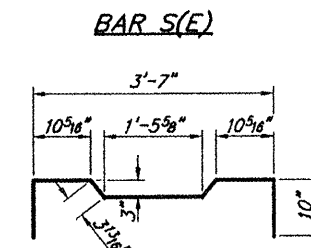

BAR S(E)

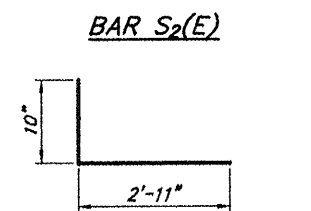

BAR S₂(E)

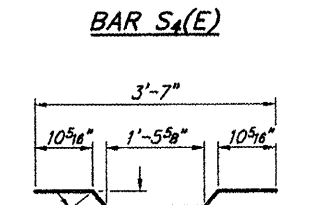

BAR S₄(E)

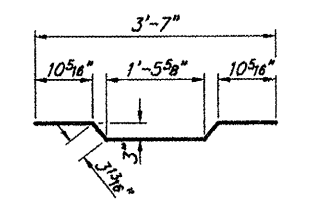

BAR A₁(E)

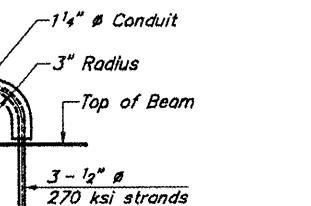

BAR U₁(E)

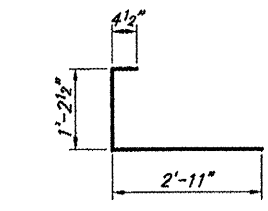

BAR S₃(E)

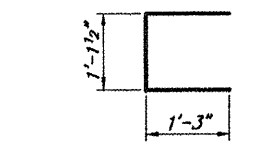

BAR U(E)

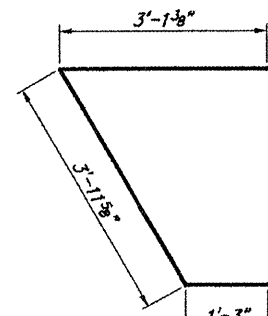

BAR U₁(E)

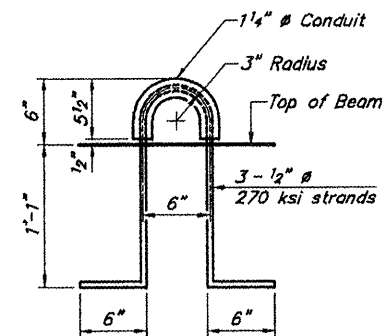

LIFTING LOOP DETAIL

BILL OF MATERIAL

Precast Prestressed Conc. Deck Bms. (17" depth)	Sq. Ft.	1112
---	---------	------

17" X 48" PPC DECK BEAM DETAILS
SPAN 2
TOWNSHIP ROUTE 23 (ELCO ROAD)
INDIAN CAMP CREEK
SECTION 09-01181-00-BR
PULASKI COUNTY
STRUCTURE NO. 077-3141