

When cantilever forming brackets are used, the work shall be done according to Article 503.06(b) of the Standard Specifications, except as modified below and in the details shown on this sheet.
 The finishing machine rails shall be placed on the top flange of the exterior beams.
 The beams or girders, supporting cantilever forming brackets, shall be tied together at 4 foot intervals.
 For Standard construction, or Stage Construction the Hardwood bracing materials shall be placed as shown between webs of beams in each bay.

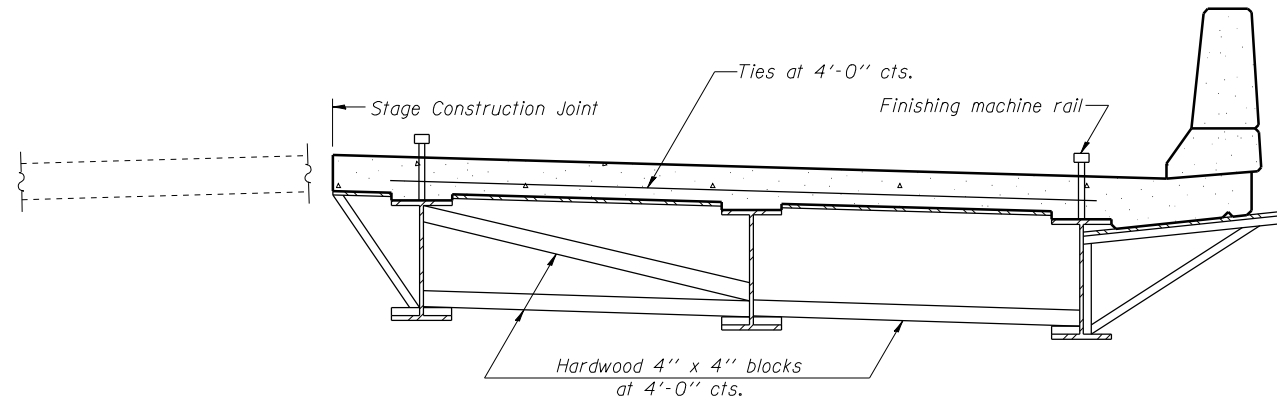

**FORM BRACES FOR
STAGE CONSTRUCTION**

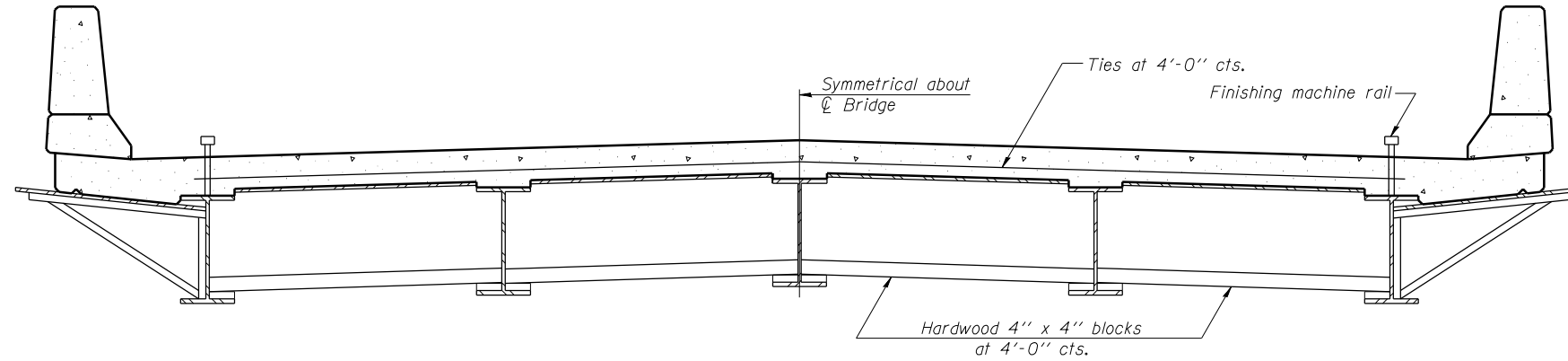

**FORM BRACES FOR
STANDARD CONSTRUCTION**

PRINT DRIVER = L:\02-ESCA\PLT
 LAYOUT NAME = PLT
 FILE NAME = 8/22/2014 7:21:26 C:\F\msh\14.dgn

SB-1

7-1-10



USER NAME = hos	DESIGNED - ELH 05/11	REVISED -
ESCA PROJECT NO. 933.14	CHECKED - RDP 04/13	REVISED -
PLOT SCALE = 0.2' / IN.	DRAWN - DWH 05/11	REVISED -
PLOT DATE = 6/10/2014 8:54:08 AM	CHECKED - ELH 05/11	REVISED -

**STATE OF ILLINOIS
DEPARTMENT OF TRANSPORTATION**

**CANTILEVER FORMING BRACKETS FOR SUPERSTRUCTURES WITH
W27 BEAMS AND SMALLER STRUCTURE NO. 093-0025**

F.A.P. RTE.	SECTION	COUNTY	TOTAL SHEETS	SHEET NO.
332	(12,B2)B-1	WABASH	68	46
CONTRACT NO. 74219			ILLINOIS FED. AID PROJECT	

SHEET NO. 26 OF 31 SHEETS