

STATE OF ILLINOIS
DEPARTMENT OF TRANSPORTATION

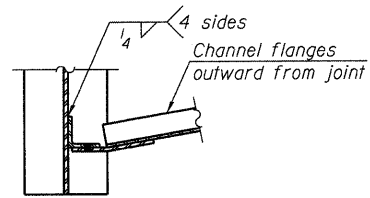

SECTION A-A

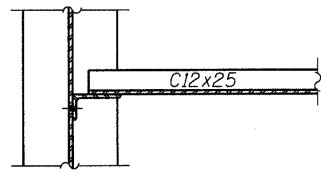

SECTION B-B

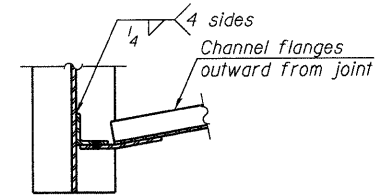

SECTION C-C

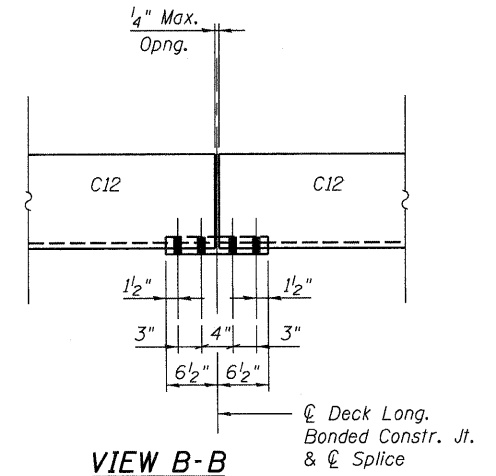

VIEW B-B

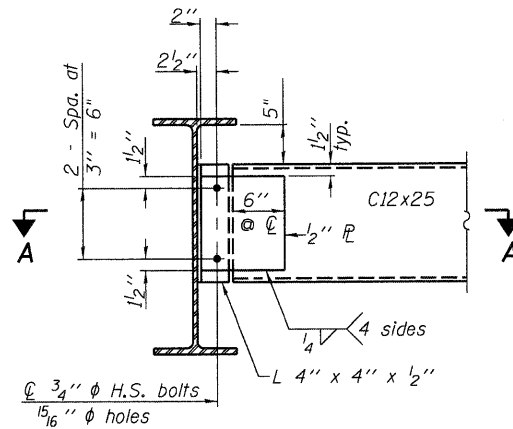

END DIAPHRAGM D1

16 Required

Note:
Two hardened washers required for each set of oversized holes.

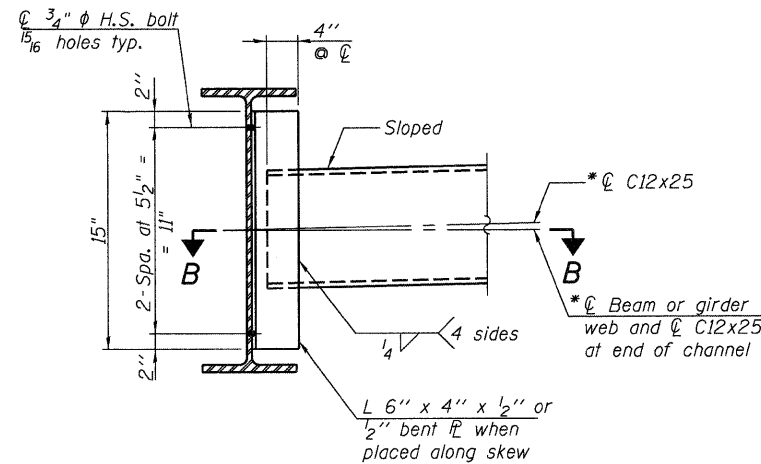

DIAPHRAGM D2

63 Required

* Alternate channel C12x30 is permitted to facilitate material acquisition. Calculated weight of structural steel is based on the lighter section. The alternate, if utilized, shall be provided at no additional cost to the Department.

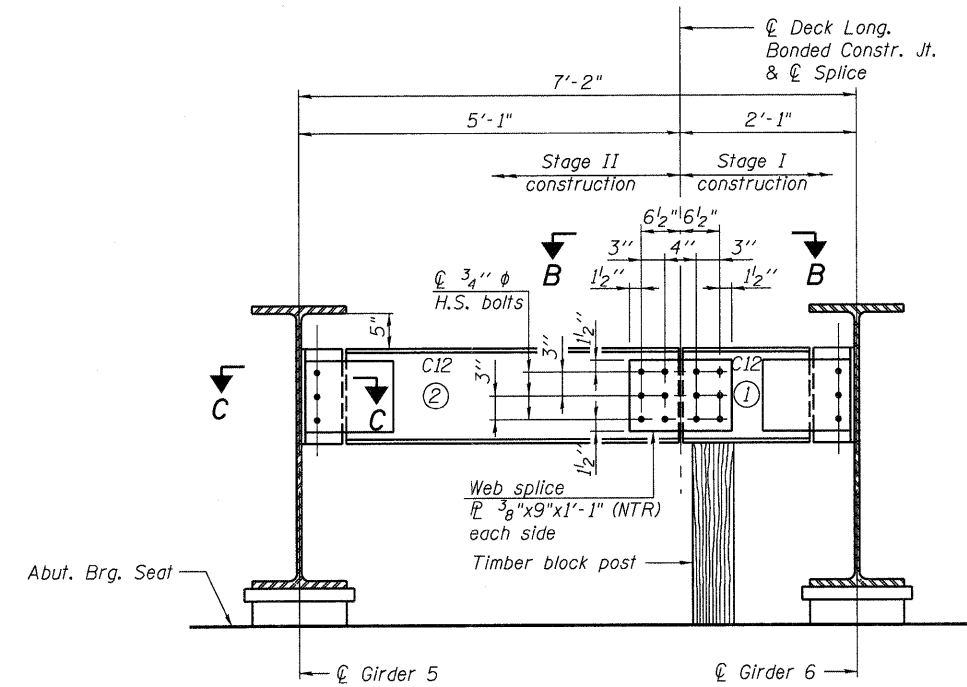

END DIAPHRAGM D3

2 Required
(Looking North at N. Abut.,
S. Abut. Similar)

END DIAPHRAGM STAGE
CONSTRUCTION SEQUENCE

- 1.) Order diaphragm D3 in two sections.
- 2.) Attach section ① of diaphragm to girder 6 during Stage I Construction.
- 3.) Place timber block posts between section ① of diaphragm and abutment bearing seat.
- 4.) Attach section ② of diaphragm to both girder 5 and section ① of diaphragm during Stage II Construction with splice plates.
- 5.) Remove timber block posts.

Notes:

1. See Sheet S20 for diaphragm locations.
2. H.S. bolts for diaphragms shall be AASHTO M164/ASTM A325 H.S. bolts Type 1, mechanically galvanized bolts. Bolts 3/4 in. ϕ , holes 15/16 in. ϕ , unless otherwise noted
3. Two hardened washers required for each set of oversized holes..
4. All diaphragms shall be installed as steel is erected and secured with erection pins and bolts except as otherwise noted. Individual cross frames or diaphragms at supports may be temporarily disconnected to install bearing anchor rods.

DESIGNED	EV
CHECKED	PC
DRAWN	JCP
CHECKED	JPO

DIAPHRAGM DETAILS
STRUCTURE NO. 016-2119

 600 WEST FULTON STREET CHICAGO, ILLINOIS 60661-1259 TEL 312 464 9100 FAX 312 559 1217 WEB www.epsteinglobal.com	SHEET NO. S21	F.A.I. RTE. 94	SECTION 1314B-1	COUNTY COOK	TOTAL SHEETS 110	SHEET NO. 57
	S52 SHEETS	CONTRACT NO. 60F65		ILLINOIS FED. AID PROJECT		