

THRIE BEAM END SHOE DETAIL

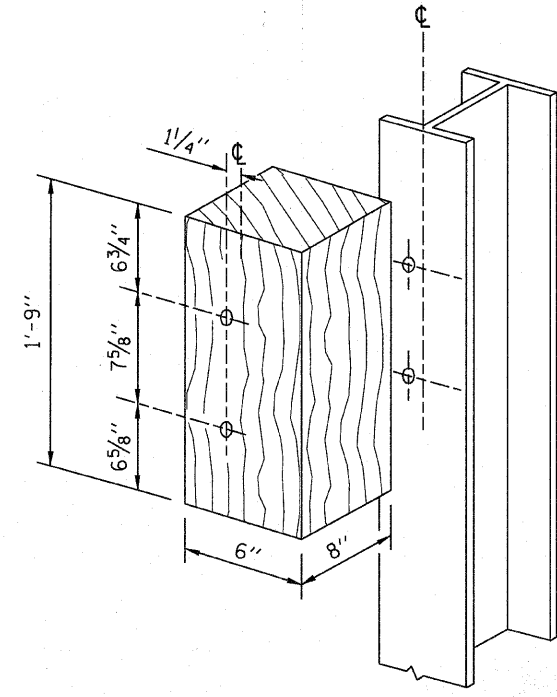

POSTS 1-11 WOOD BLOCKOUT DETAIL

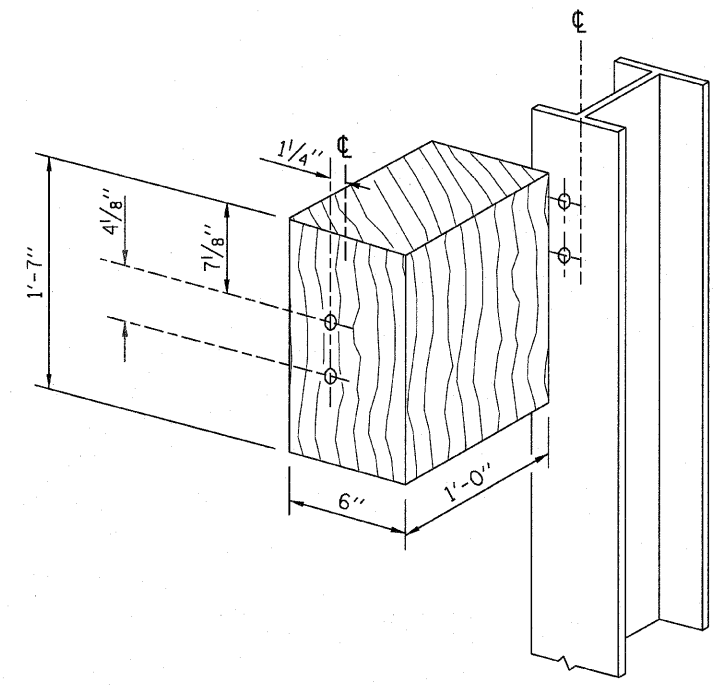

POST 12 WOOD BLOCKOUT DETAIL
(SEE STANDARD C1 FOR POST 13-17 BLOCKOUTS.)

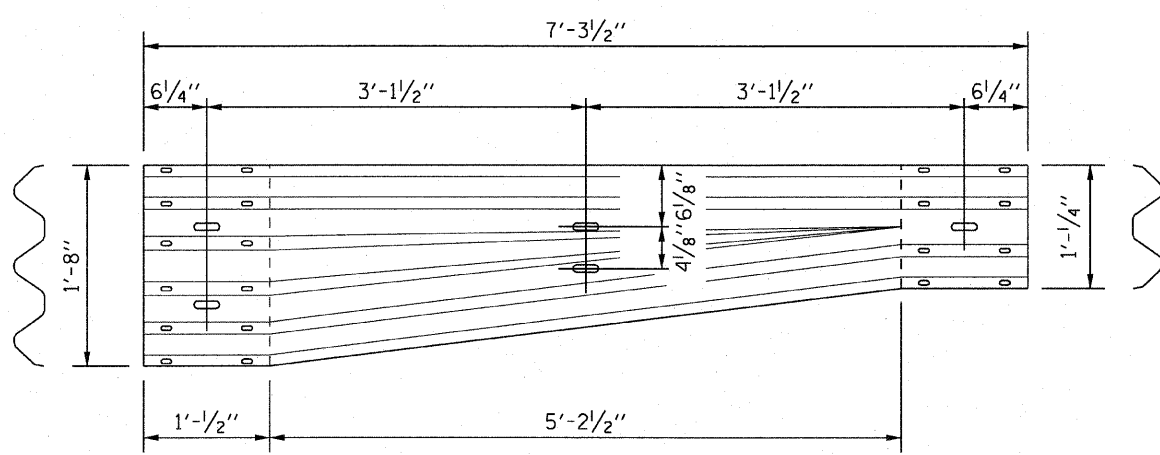

TRANSITION SECTION
(10 GAUGE RAIL ELEMENT)

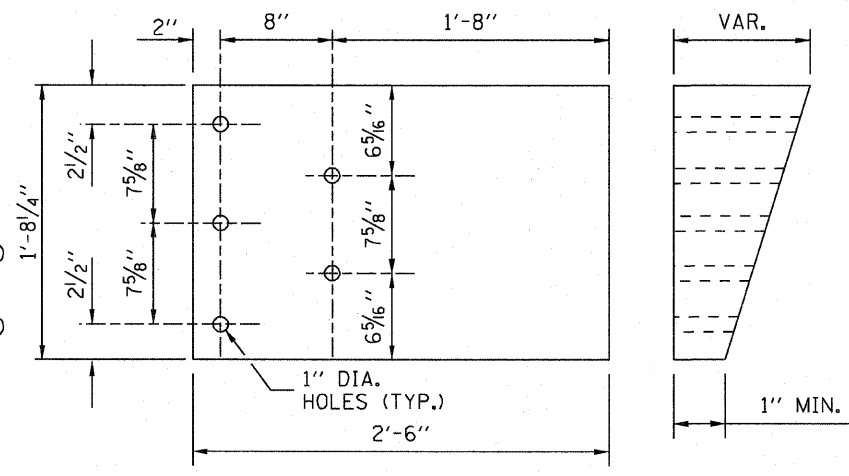

PARAPET WOOD BLOCK-OUT DETAIL

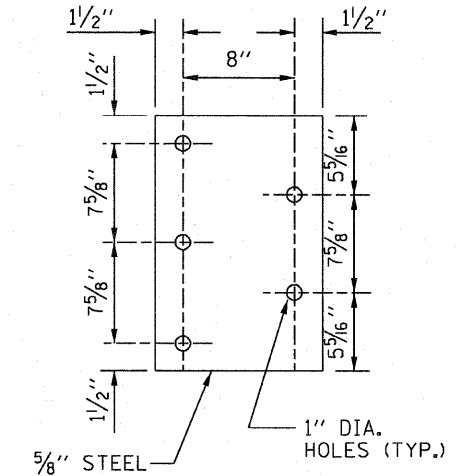

PARAPET STEEL BEARING PLATE DETAIL
(5 EACH INDIVIDUAL 5"x5"x5/8" STEEL PLATES WITH CENTERED 1" HOLES MAY BE SUBSTITUTED FOR THE PLATE SHOWN.)

APPROVED.....
Paul Kovacs
 CHIEF ENGINEER DATE 7-1-2009

NOTE:
 SEE SHEET 1 OF THIS SERIES FOR NOTES.

Illinois Tollway
 Open Roads for a Faster Future

TRAFFIC BARRIER
 TERMINAL, TYPE T6

STANDARD C9-01

406 OF 516