

STATE OF ILLINOIS
DEPARTMENT OF TRANSPORTATION

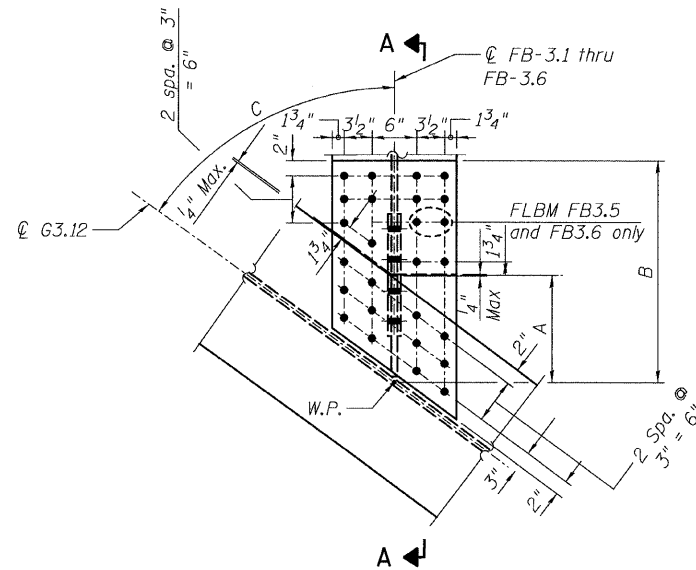

DETAIL 27
(Top Flange)

Floor Beam	Dimensions		
	A	B	C
FB-3.1	11 ³ / ₁₆ "	1'-9 ⁵ / ₈ "	84°48'52"
FB-3.2	11 ⁵ / ₁₆ "	1'-10 ³ / ₈ "	79°41'29"
FB-3.3	11 ¹ / ₂ "	1'-11 ¹ / ₈ "	75°19'51"
FB-3.4	11 ³ / ₄ "	2'-0"	70°52'53"
FB-3.5	1'-0 ³ / ₄ "	2'-2 ⁹ / ₁₆ "	60°39'14"
FB-3.6	1'-1 ⁵ / ₁₆ "	2'-2 ¹³ / ₁₆ "	56°35'41"

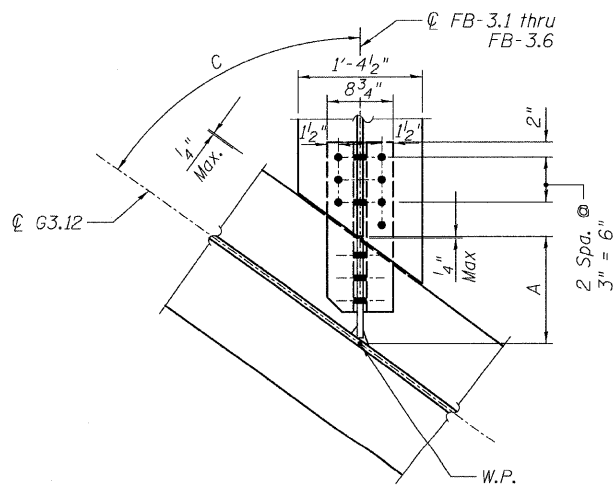

SECTION B-B
(Bottom Flange)

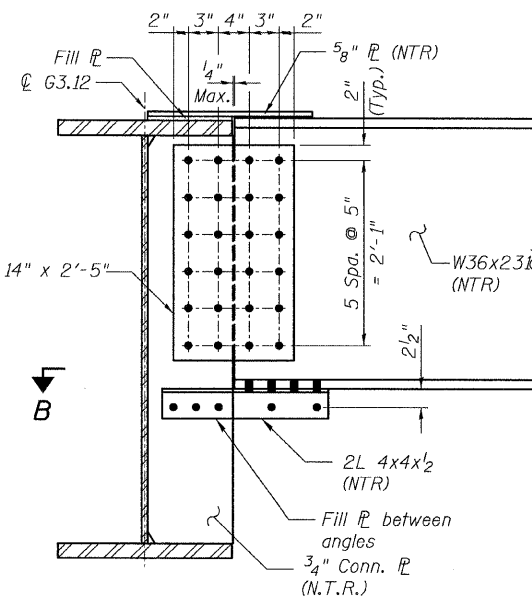

SECTION A-A

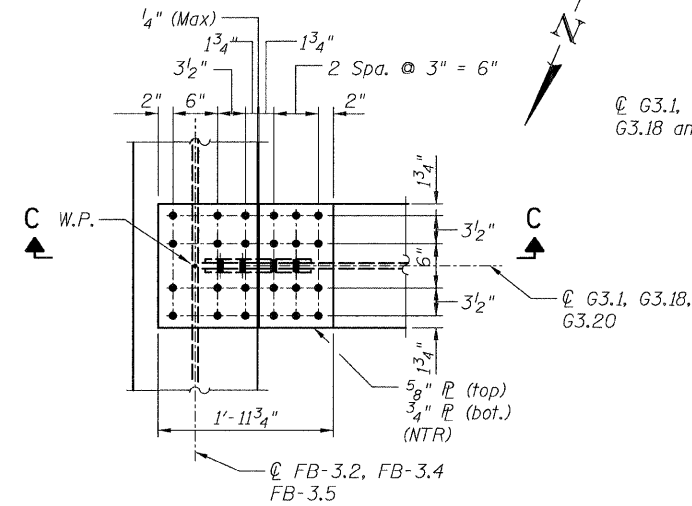

DETAIL 28
(Top Flange)
(Bottom Flange Similar)

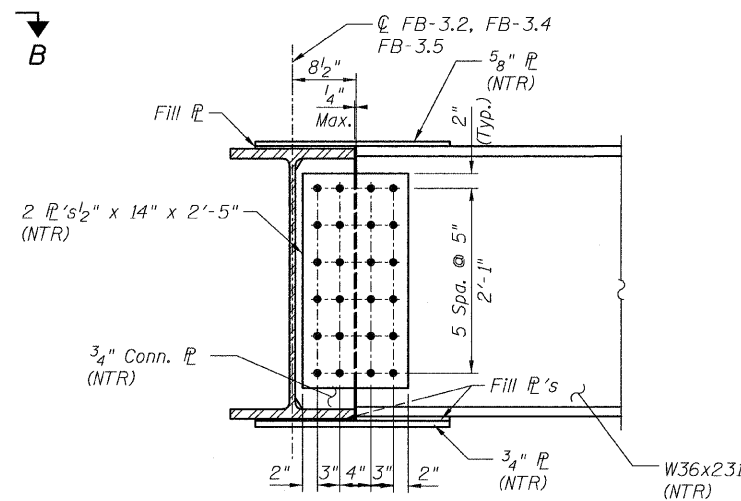

SECTION C-C

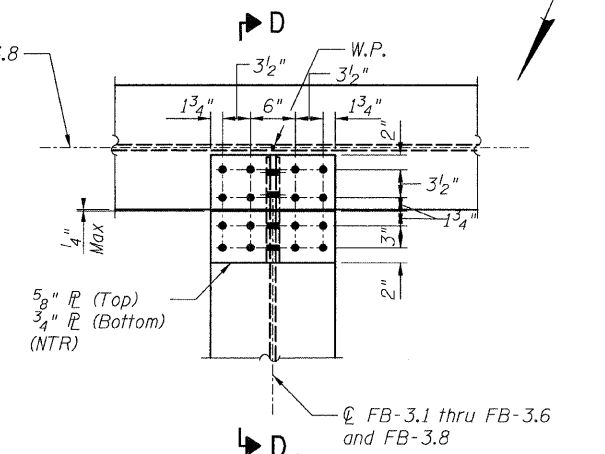

DETAIL 29
(Top Flange)
(Bottom Flange Similar)

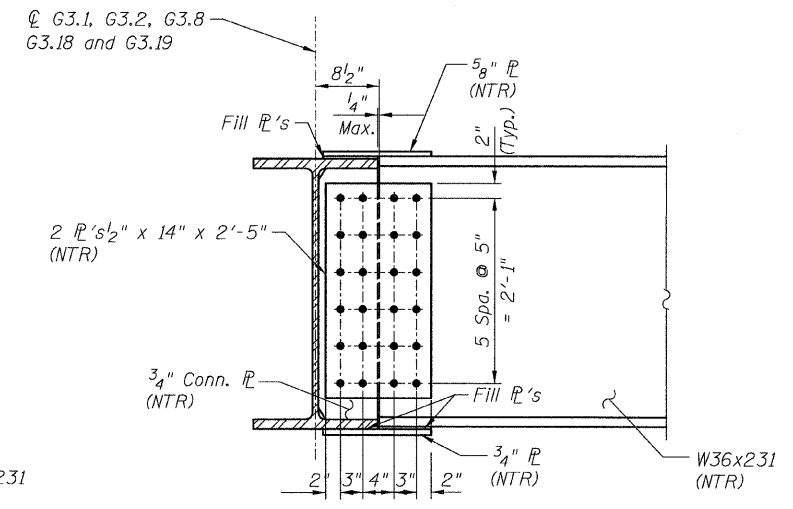

SECTION D-D

NOTES:

- All steel shall be AASHTO M 270 Grade 50.
- Load carrying components designated "N.T.R." shall conform to the supplemental requirements for Notch Toughness, Zone 2.

CONNECTION DETAILS 27, 28 & 29
RAMP 3 FLARE
STRUCTURE NO. 016-0724

TYLIN INTERNATIONAL

DESIGNED - JPN	REVISIONS	
	NAME	DATE
CHECKED - AMD,		
DRAWN - JMA		
CHECKED - AMD,		
DATE - 08/02/10		

SHEET NO. 106 137 SHEETS	F.A.I RTE. 55	SECTION 0711.2R & 1011.1BR	COUNTY COOK	TOTAL SHEETS 200	SHEET NO. 136
	CONTRACT NO. 60L39				
FED. ROAD DIST. NO. 1 ILLINOIS FED. AID PROJECT					