

**DETAIL 1: GRATE FRAME AT THICKENED SLAB**  
N.T.S.

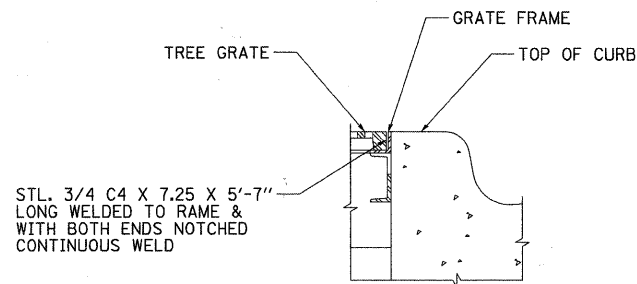

**DETAIL 2: GRATE FRAME ABUTTING BACK OF CONCRETE CURB**  
N.T.S.

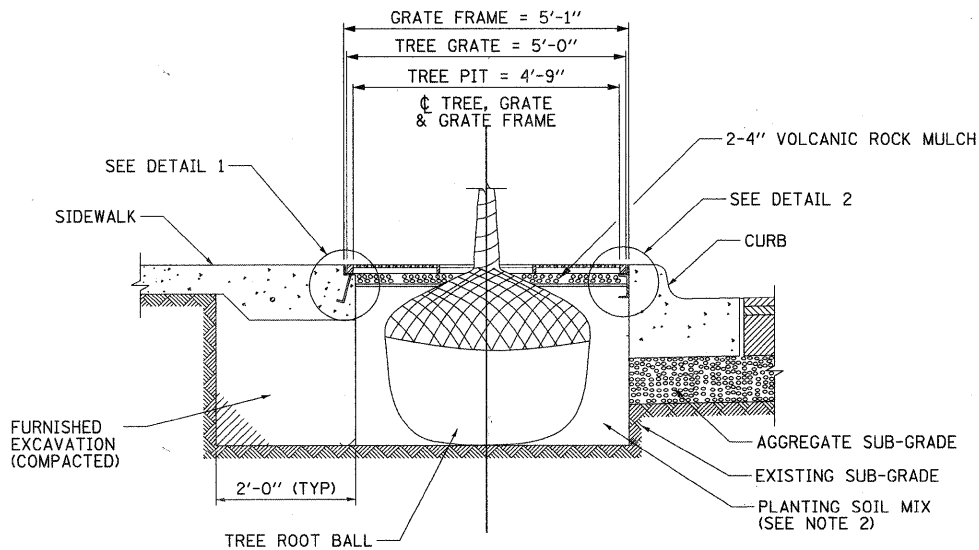

**TREE PIT - CROSS SECTION (WITH STEEL TREE GRATE FRAME)**  
N.T.S.

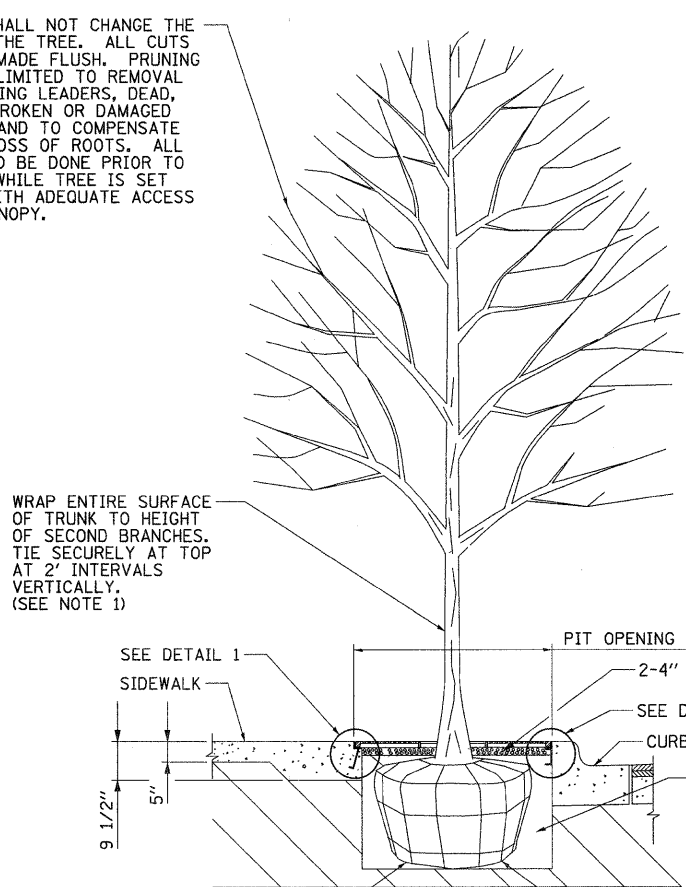

**TREE PLANTING DETAIL**  
N.T.S.

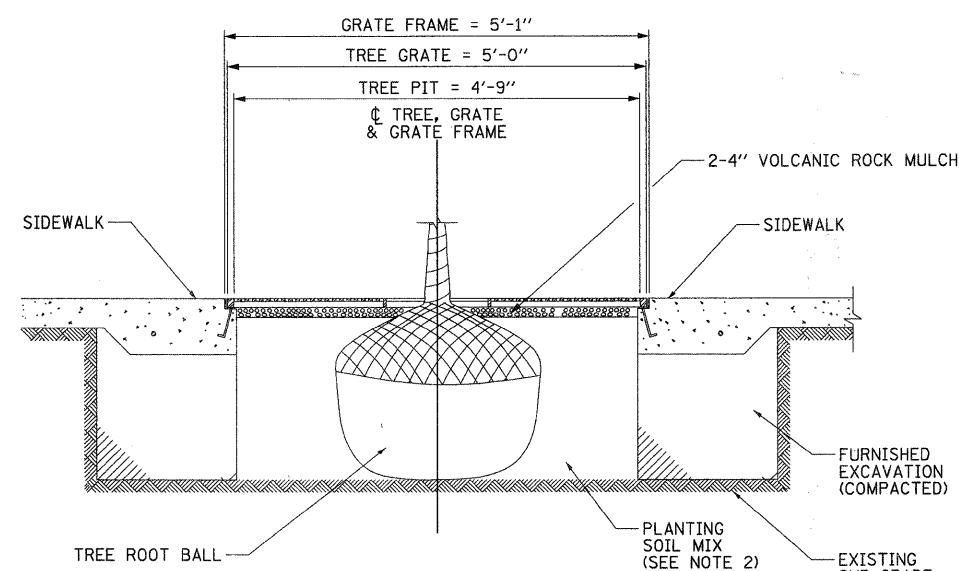

**TREE PIT - LONGITUDINAL SECTION**  
N.T.S.

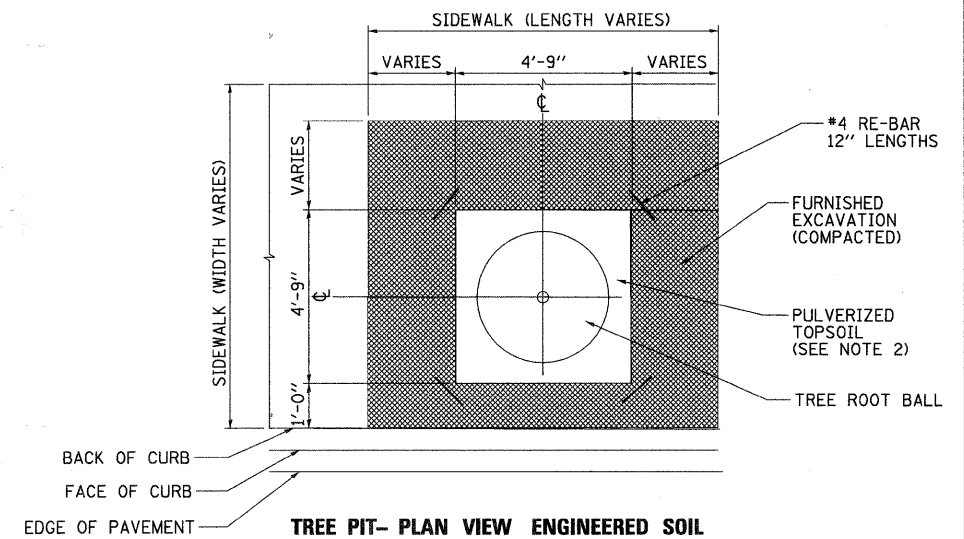

**TREE PIT- PLAN VIEW ENGINEERED SOIL**  
N.T.S.

**NOTES:**

- HAND EXCAVATION IS REQUIRED AT LEAST 18 INCHES ON EITHER SIDE OF A MARKED FACILITY. CONSTRUCTOR/EXCAVATOR IS EXPECTED TO HONE ALL TIME/MARKING REQUIREMENTS AND DIG IN A REASONABLE AND PRUDENT MANNER, TAKING ALL REASONABLE AND REQUIRED PRECAUTIONS TO AVOID DAMAGING UNDERGROUND FACILITIES. IF DAMAGE TO AN UNDERGROUND FACILITY SHOULD OCCUR, IMMEDIATELY CONTACT THE ENGINEER AND THE OWNER OF THE DAMAGED FACILITY TO REPORT THE DAMAGE.

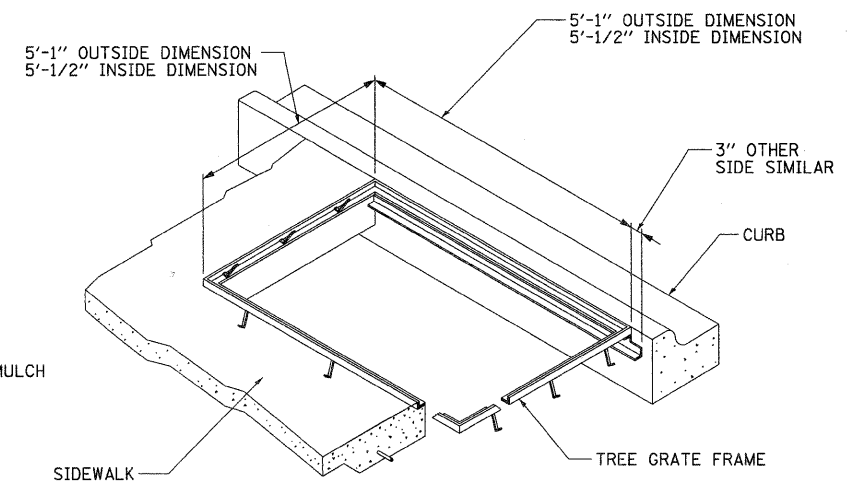

**TREE GRATE FRAM INSTALLATION AT CURB**  
N.T.S.

**NOTES:**

- TREE WRAP SHOULD ONLY BE INSTALLED DURING THE FALL PLANTING SEASON ON SPECIES SUSCEPTIBLE TO FROST CRACKING OR SUN SCALD.
- PLANTING SOIL MIX SHOULD CONSIST OF TOPSOIL, LEAF COMPOST, PERLITE, PROCESSED PINE BARK AND PEAT MOSS. NO MUSHROOM COMPOST IS TO BE USED. LIME MAY BE ADDED.



FILE NAME = 066_650landscape_detail.dgn	USER NAME = #USER#	DESIGNED - J.G.	REVISED -
PLOT SCALE = 1/2\"/>			

<b>VILLAGE OF VILLA PARK, ILLINOIS</b>			
SCALE: NO SCALE	SHEET NO. 6	OF 6 SHEETS	STA. 63+19.78 TO STA. 116+71.35

<b>LANDSCAPING DETAILS</b>			
F.A. U. RTE. 2652	SECTION 00-00070-00-PV	COUNTY DuPAGE	TOTAL SHEETS 160 SHEET NO. 66
CONTRACT NO. 63379			

FED. ROAD DIST. NO.	ILLINOIS	FED. AID PROJECT
---------------------	----------	------------------