

**STAGE 1 - SUGGESTED CONSTRUCTION SEQUENCE**

- 1 PERFORM STAGE 1 STRUCTURE AND SHOULDER REMOVAL FOR CONSTRUCTION OF HODGES CREEK STRUCTURE (SN 059-0510).
- 2 DRIVE SHEET PILING PRIOR TO ANY EXCAVATION.
- 3 PERFORM ALL EXCAVATION WORK FOR STAGE 1 STRUCTURE (SN 059-0510).
- 4 PERFORM ALL CONSTRUCTION WORK FOR STAGE 1 STRUCTURE (SN 059-0510).
- 5 INSTALL TEMPORARY RAMPS AT EACH END OF STRUCTURE (SN 059-0510) FOR STAGE 2 TRAFFIC.
- 6 REMOVE TEMPORARY PAVEMENT MARKINGS.
- 7 ALL FINAL RESURFACING WILL BE COMPLETED IN STAGE 3.

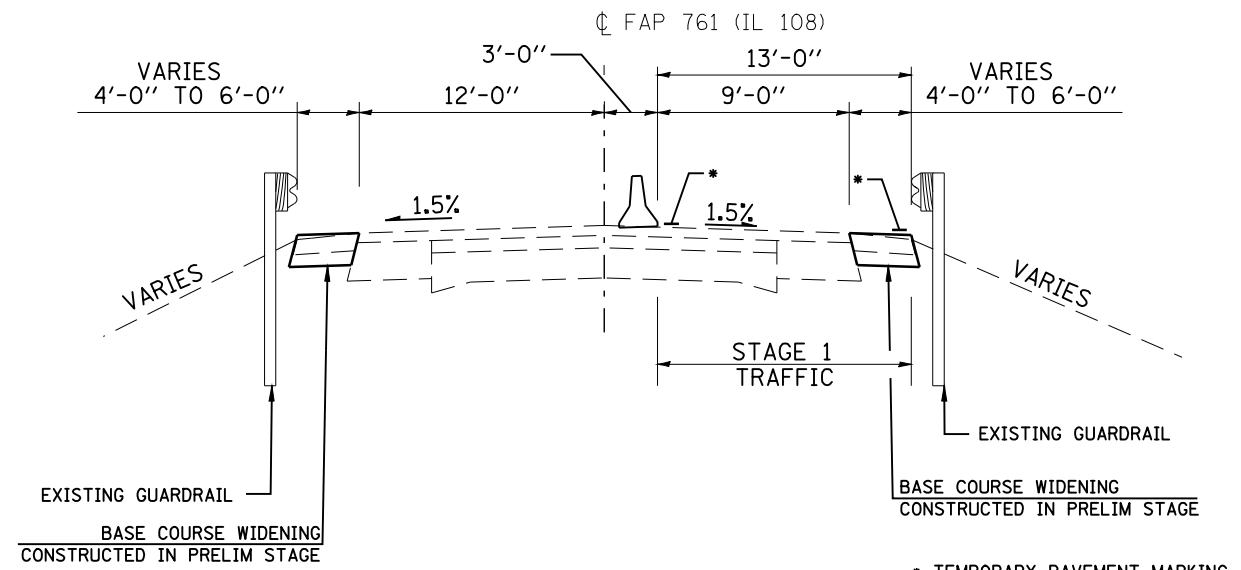

**LEGEND**

	- BRIDGE CONSTRUCTION, STAGE I		- TEMPORARY BRIDGE TRAFFIC SIGNALS
	- IMPACT ATTENUATOR, NARROW		- DRUM WITH STEADY BURNING LIGHT
	- TEMPORARY BARRIER WALL		- 24" STOP BAR
	- HOT-MIX ASPHALT BINDER COURSE RAMP		- TYPE III BARRICADES
	- BASE COURSE WIDENING, 10"		- TYPE C BIDIRECTIONAL REFLECTOR
	- SIGN		- STEADY BURNING LIGHTS AND DOUBLE VERTICAL PANELS
	- INDUCTION LOOP DETECTOR		- TEMPORARY RUMBLE STRIP

FILE NAME =	USER NAME = laughlinr1	DESIGNED -	REVISED -	<b>STATE OF ILLINOIS DEPARTMENT OF TRANSPORTATION</b>	<b>MAINTENANCE OF TRAFFIC - STAGE I</b>			F.A.P. RTE.	SECTION	COUNTY	TOTAL SHEETS	SHEET NO.
et:\pw\work\PWIDOT\LAUGHLINRL\0212999\672A94-Sht-Staging\ph2.dgn	PLOT SCALE = 60.0000' / IN.	DRAWN -	REVISED -					761	107B-2	MACOUPIN	98	17
PLOT DATE = Jun-28-2010 02:00:48PM	DATE -	CHECKED -	REVISED -		CONTRACT NO. 72A94			ILLINOIS FED. AID PROJECT				
		DATE -	REVISED -		SCALE:	SHEET NO.	OF SHEETS	STA.	TO STA.			