

STATE OF ILLINOIS
DEPARTMENT OF TRANSPORTATION

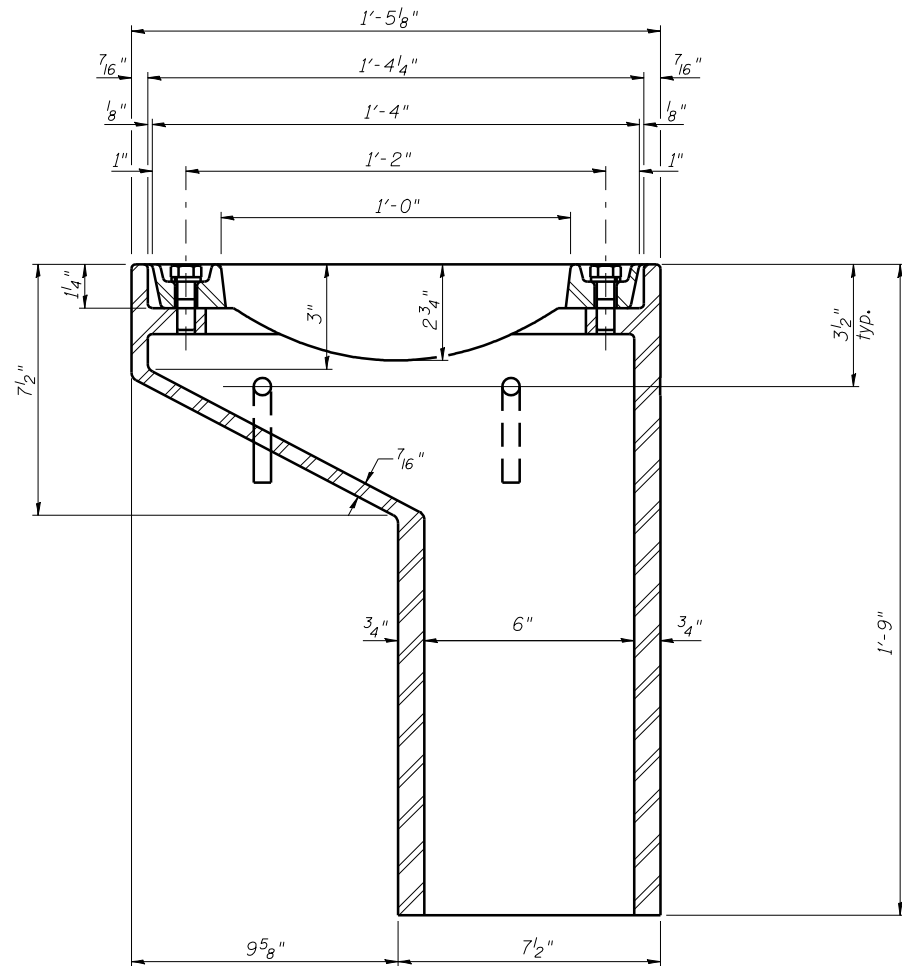

SECTION A-A
See sheet of for scupper location relative to parapet.

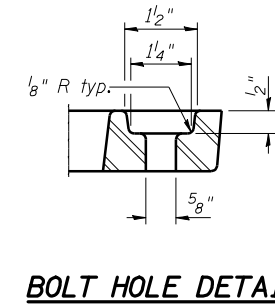
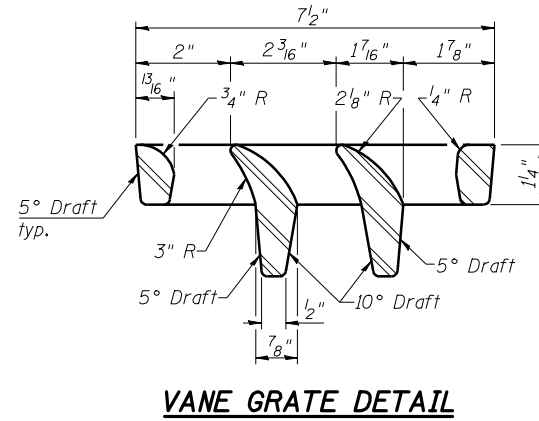
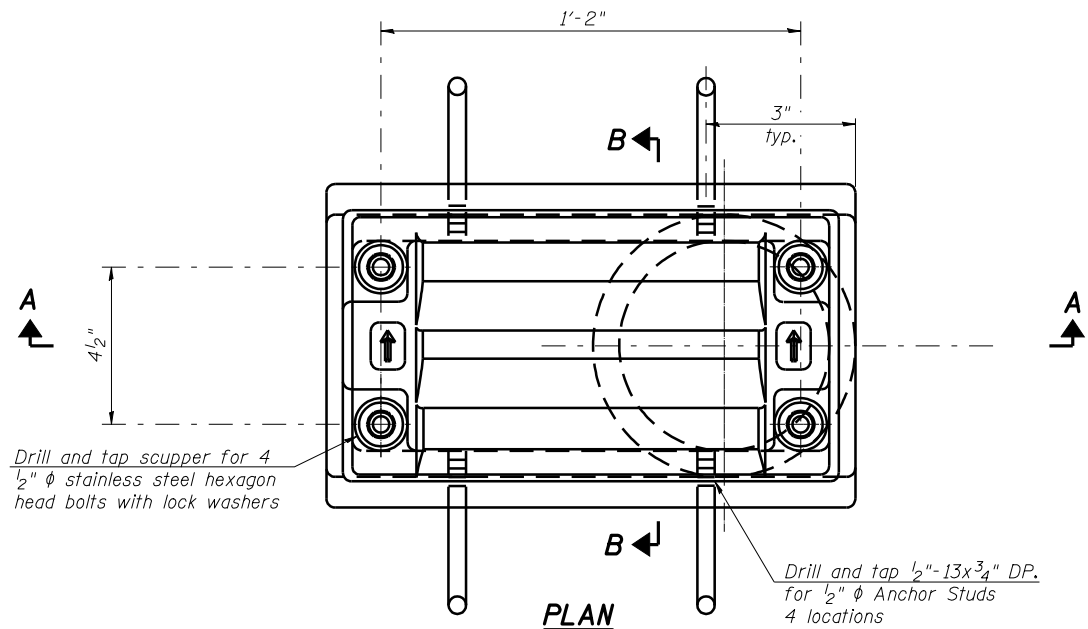
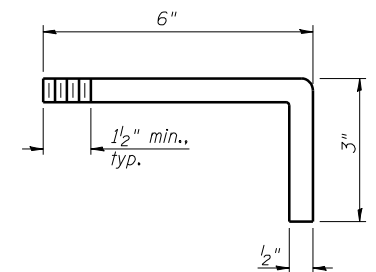
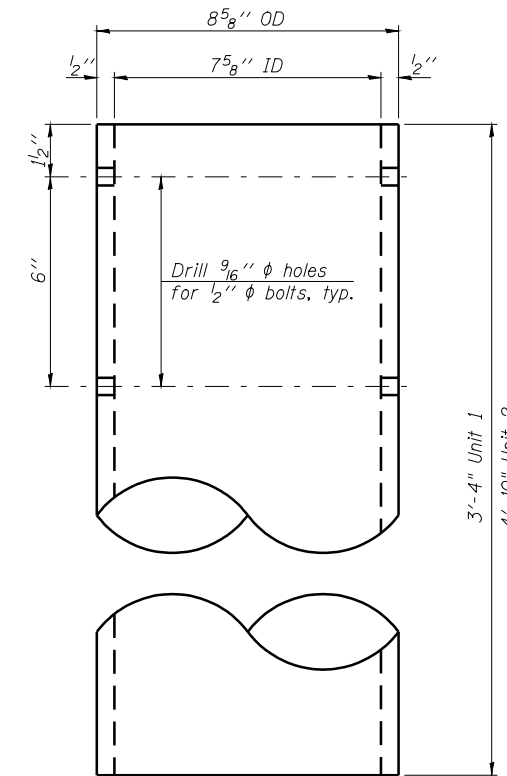
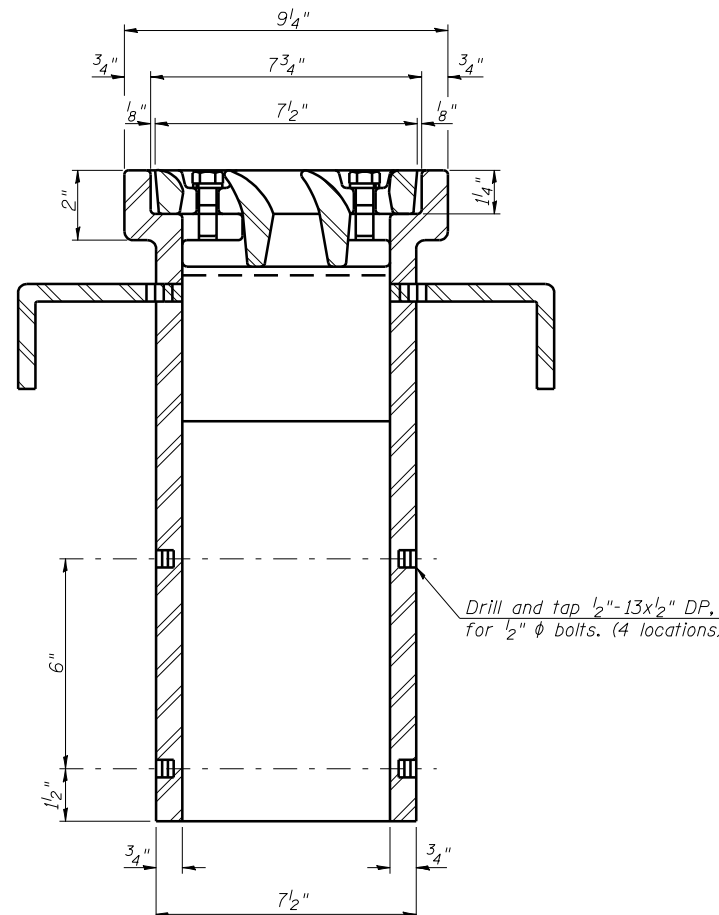

ANCHOR STUD DETAIL

BILL OF MATERIAL

ITEM	UNIT	QUANTITY
Drainage Scupper, DS-11	Each	6

DRAINAGE SCUPPER, DS-11
STRUCTURE NUMBER 059-0510

SHEET NO. 23 OF 51 SHEETS	F.A.P. RTE.	SECTION	COUNTY	TOTAL SHEETS	SHEET NO.
	761	107B-2	MACOUPIN	98	53
FAP ROUTE 761 (IL RT 108)			CONTRACT NO. 72A94		
FED. ROAD DIST. NO.		ILLINOIS FED. AID PROJECT			

Notes:
All cast iron parts shall be gray iron conforming to the requirements of AASHTO M 105, Class 35B.
Bolts, anchor studs, washers and nuts shall conform to the requirements of ASTM A 307 and shall be galvanized according to AASHTO M 232.
Downspouts located on the exterior side of a painted steel fascia beam shall be painted with the finish coat specified for the exterior side of the fascia beam.
As an alternate, bolts, anchor studs, washers and nuts may be stainless steel according to Article 1006.29(d) of the Standard Specifications.
Structural steel weldments of equal sections and of the same configuration may be substituted for the cast iron scupper frame. Fillet or full penetration welds shall be used for the weldments. Details shall be submitted to the Engineer for approval. Structural steel weldments shall not be substituted for the cast iron scupper grate. Structural steel frames and downspouts shall be galvanized according to AASHTO M11.
The Contractor shall take appropriate measures to assure that Protective Coat is not applied to the scupper.
Cost of the Grate, Frame, Downspout, Anchor Studs, Bolts, Washers and Nuts including complete installation of the scupper shall be paid for at the contract unit price each for Drainage Scupper, DS-11.
Alternate fiberglass downspout conforming to ASTM D 2996 with a short-time rupture strength hoop tensile stress of 30,000 psi min. may be used in lieu of the cast iron or steel equivalent.

DESIGNED -	J.M.B.
CHECKED -	T.E.S.
DRAWN -	R KING
CHECKED -	J.M.B.

HOMER L.
CHASTAIN
& ASSOCIATES, LLP
CONSULTING ENGINEERS

DECATUR (217) 422-8544
CHICAGO (773) 714-0050
ROCKFORD (815) 489-0050

184-001397

DS-11

11-1-09