

FAS NO	SECTION	COUNTY	TOTAL SHEETS	SHEET NO.
340	10-00112-00-RS		3	3
PROJECT RS- 0340(104)				
CONTRACT # 87454				

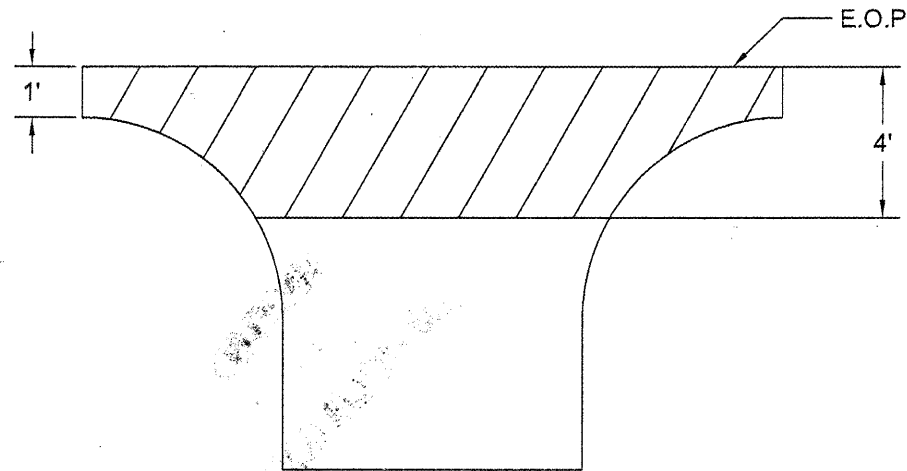

**TYPICAL FIELD & PRIVATE ENTRANCE**

32 EACH

LT. STA.	LT. STA.	RT. STA.	RT. STA.
6+95	65+75	6+55	67+65
9+65	72+70	9+30	93+25
13+30	77+00	13+30	106+55
20+40	80+30	29+10	138+10
21+30	96+85	31+80	143+72
26+80	98+95	63+00	156+05
29+50	114+95		
32+15	131+85		
50+90	140+35		
63+30	151+40		

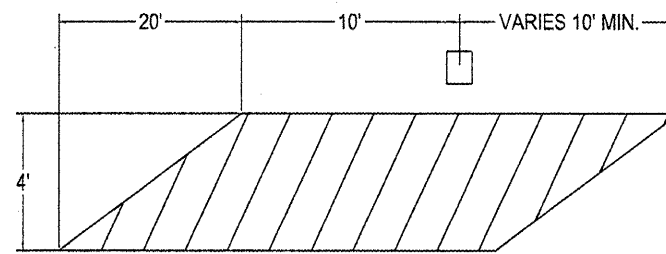

**TYPICAL MAILBOX FOLLOWING**

1 EACH  
STA. 98+80 LT

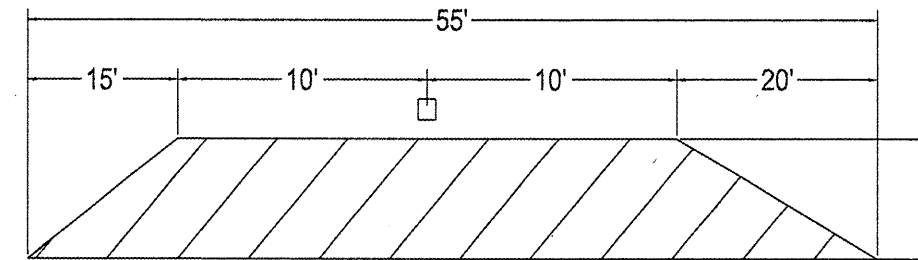

**TYPICAL MAILBOX TURN OUT**

1 EACH  
STA. 77+55 LT

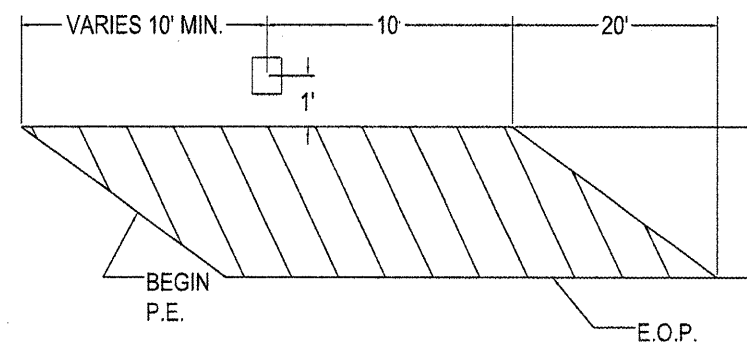

**TYPICAL MAILBOX LEAD IN**

0 EACH

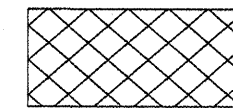

AREA TO BE PAID AS  
INCIDENTAL BITUMINOUS SURFACING

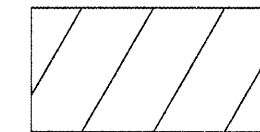

AREA TO BE CONSTRUCTED  
DURING MAINLINE PAVING OPERATIONS  
SLOPE = 3/4" PER FOOT

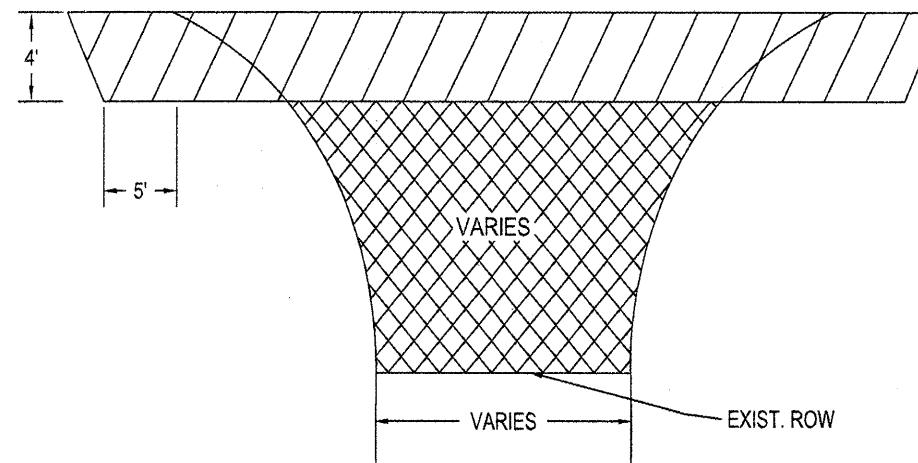

**TYPICAL SIDE ROAD RETURN**

2 EACH  
STA. 53+35 RT & LT

**NOTES**

1. USE SAME MAINLINE MATERIAL FOR SIDE ROAD RETURNS, FIELD & PRIVATE ENTRANCES, AND MAILBOXES.
2. AGGREGATE SHOULDERS TO BE PLACED BEHIND SIDE ROAD RETURNS, FIELD & PRIVATE ENTRANCES, AND MAILBOXES AS DIRECTED BY THE ENGINEER.
3. SHORT TERM PAVEMENT MARKINGS TO BE REMOVED BY FORD COUNTY PERSONNEL.
4. THE FOLLOWING APPLICATION RATES HAVE BEEN ASSUMED IN CALCULATING QUANTITIES:

GRANULAR MATERIALS	2.00 TON / CU YD
BIT MATL (PR CT)	0.075 GAL / SQ YD
AGGREGATE (PR CT)	0.001 TON / SQ YD
BIT CONC	112 # / SQ YD / INCH
SHORT TERM PVMT MKING	4 FT / 40 FT OF APPL.