

**STAGE II**

STAGE II NOTES

I. MAINLINE

A. CLASS A PATCHING

- LANE CLOSURES PER STANDARDS 701400, 701401, AND 701446
- WORK SHALL BE PERFORMED FROM 8:00 PM FRIDAY TO 5:00 AM MONDAY.

B. SHOULDER AND LANE CLOSURES PER STANDARDS 701101 AND 701401 FOR TRAFFIC CONTROL DURING ALLOWABLE SHOULDER AND LANE CLOSURES IDENTIFIED IN THE SPECIAL PROVISIONS.

C. SHOULDER WORK AND EMBANKMENT

- OUTSIDE SHOULDERS. SHOULDER AND LANE CLOSURES AND PARTIAL RAMP CLOSURES PER STANDARDS 701101, 701400 AND DISTRICT DETAIL TC-17 FOR TRAFFIC CONTROL DURING ALLOWABLE CLOSURES IDENTIFIED IN THE SPECIAL PROVISIONS.
- MEDIAN. TRAFFIC CONTROL PER MAINTENANCE OF TRAFFIC PLANS. PERMANENT LANE CLOSURES SHOWN IN STAGE I FOR I-80 SHALL NOT EXCEED 30 CALENDER DAYS. TEMPORARY LANE CLOSURES OUTSIDE THE 30 CALENDER DAYS ALLOWED AS STIPULATED IN THE SPECIAL PROVISIONS

- II. THE CONTRACTOR SHALL ERECT ROAD CONSTRUCTION AHEAD SIGNS (W20-1103(O)-4B) WITH FLASHING BEACON ON ALL ARTERIAL ROADWAYS APPROACHING INTERCHANGE RAMP.
- III. REMOVAL OF TEMPORARY PAVEMENT MARKING, WHEN REQUIRED, SHALL BE PAID FOR AS "WORK ZONE PAVEMENT MARKING REMOVAL".
- IV. REMOVAL OF EXISTING PAVEMENT MARKING, WHEN REQUIRED, SHALL BE PAID FOR AS "PAVEMENT MARKING REMOVAL".
- V. EXISTING OR TEMPORARY PAVEMENT MARKINGS REMOVED DURING MILLING OPERATIONS WILL NOT BE PAID SEPARATELY.
- VI. CASTINGS EXPOSED IN TRAVEL LANES SHALL BE PROTECTED PER APPLICABLE PORTIONS OF ARTICLE 603.07 OF THE STANDARD SPECIFICATIONS. THIS WORK WILL NOT BE PAID FOR SEPARATELY, BUT SHALL BE INCLUDED IN THE VARIOUS HMA BINDER AND SURFACE COURSES PLACED.

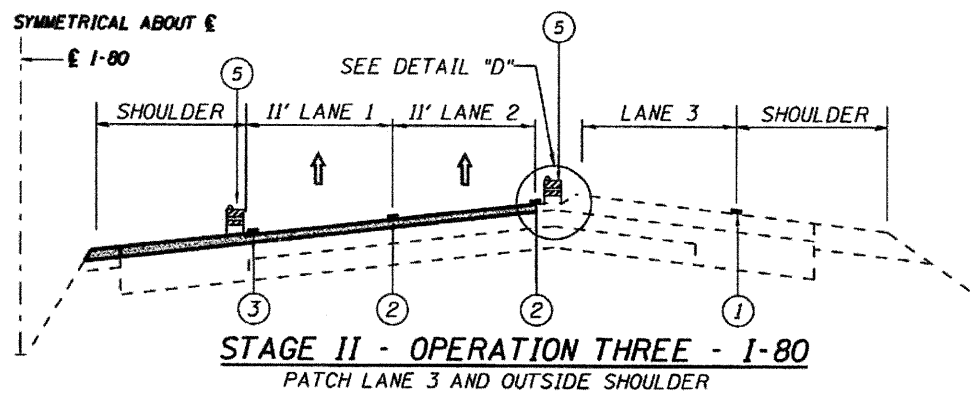
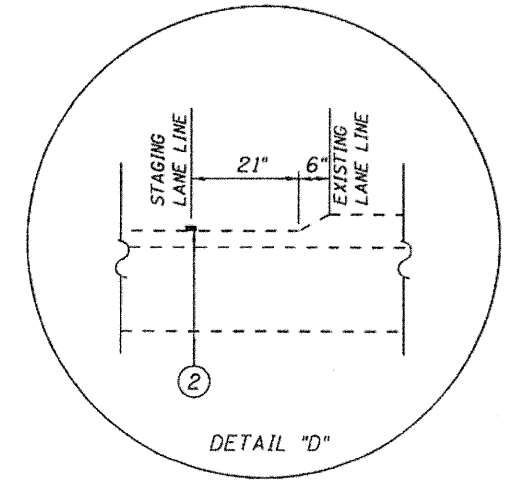
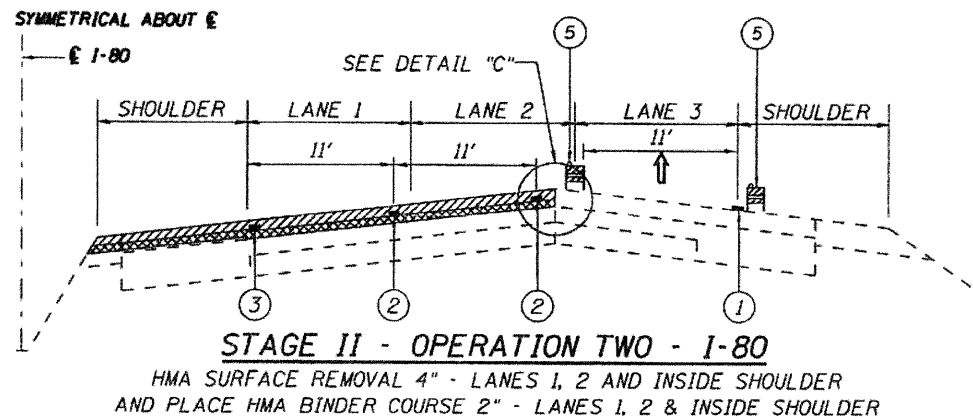
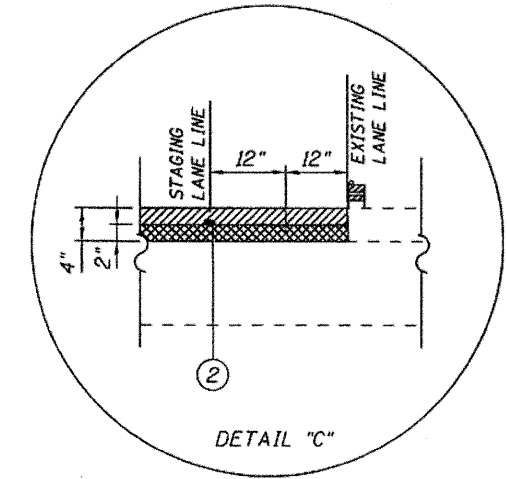
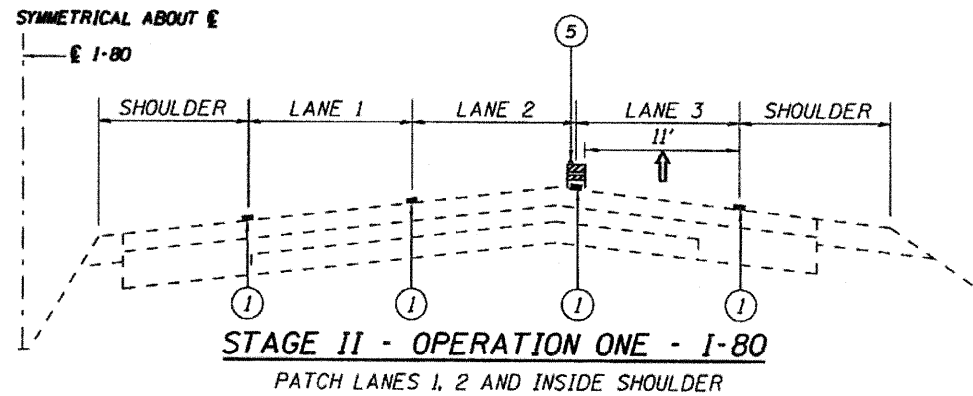

- LEGEND**
- ① EXISTING PAVEMENT MARKING
  - ② WET REFLECTIVE TEMPORARY TAPE, TYPE III, 5" (10' DASH - 30' SKIP) \*
  - ③ WET REFLECTIVE TEMPORARY TAPE, TYPE III, 4" \* (YELLOW LEFT & WHITE RIGHT) INSTALLED WITHIN 24 HOURS OF MILLING OR BINDER PLACEMENT.
  - ④ PROPOSED PAVEMENT MARKING. SEE PAVEMENT MARKING PLANS.
  - ⑤ VERTICAL BARRICADES WITH STEADY BURNING MONO DIRECTIONS LIGHT AT 100' C-C SPACING.
- \* - USE EPOXY PAVEMENT MARKING ON MILLED SURFACE

**LONCO, INC.**  
CONSULTING ENGINEERS  
1560 BALL ST, SUITE 222  
NAPERVILLE, ILLINOIS 60563 PH: 630.251.5177-9100

DESIGNED - MJY  
DRAWN - TS, ST, SV  
CHECKED - MJY  
DATE - 07/08/2009

REVISED -  
REVISED -  
REVISED -

STATE OF ILLINOIS  
DEPARTMENT OF TRANSPORTATION

SUGGESTED MAINTENANCE OF TRAFFIC  
I-80 (EAST OF 80th AVE. TO I-294)

SCALE: NONE SHEET NO. 2 OF 3 SHEETS STA. 81+61 TO STA. 427+00

F.A.I. RTE.	SECTION	COUNTY	TOTAL SHEETS	SHEET NO.
80	(95-5-1, ETC, 1819-824) RS-2	WILL & COOK	80	26
C-91-145-09		CONTRACT NO. 60F61		
FED. ROAD DIST. NO.		ILLINOIS FED. AID PROJECT		