

STAGE II (CONTINUED)

STAGE II NOTES

1. SEQUENCE OF CONSTRUCTION: PAVEMENT PATCHING, HMA SURFACE REMOVAL AND PROPOSED HMA COURSE AS DETAILED IN EACH OPERATION SECTION. WORK CAN OCCUR CONCURRENTLY, BUT SEQUENCE SHALL BE MAINTAINED AND NOT CONFLICT. THE TWO LANE SECTION OF I-80 WILL FOLLOW THE SEQUENCE OF LANES 1 AND 3 IN THE OPERATION SECTIONS. RAMP WORK WILL BE COMPLETED USING DISTRICT DETAIL TC-18 - FREEWAY AND EXIT RAMP CLOSURE DETAILS.
2. LANE AND RAMP CLOSURES ALLOWED AS STIPULATED IN THE SPECIAL PROVISIONS.
3. HMA SURFACE REMOVAL AND RESURFACING OPERATIONS FOR STAGE II SHALL NOT BEGIN UNTIL STAGE I IS COMPLETED.
4. LANE CLOSURES PER STANDARDS 701400, 701401 AND 701446.
5. REDUCE LANE WIDTH USING 35:1 TAPER PER DISTRICT TC-9 - TRAFFIC CONTROL DETAILS FOR FREEWAY SINGLE AND MULTI-LANE WEAVE. A W5-1 (48 X 48) ROAD NARROWS SIGN WILL BE ERECTED 500' IN ADVANCE OF THE TAPER.
6. THE CONTRACTOR SHALL ERECT ROAD CONSTRUCTION AHEAD SIGNS (W20-1103(O)-48) WITH FLASHING BEACON ON ALL ARTERIAL ROADWAYS APPROACHING INTERCHANGE RAMP.
7. GRADE DIFFERENTIAL BETWEEN LANES SHALL NOT EXCEED 2".
8. PARTIAL MILLING OF PAVEMENT FOR AN OPERATION WILL NOT BE PAID FOR SEPARATELY, BUT WILL BE PAID FOR AT THE FINAL MILLING THICKNESS SHOWN ON THE TYPICAL SECTIONS.
9. REMOVAL OF TEMPORARY PAVEMENT MARKING, WHEN REQUIRED, SHALL BE PAID FOR AS "WORK ZONE PAVEMENT MARKING REMOVAL".
10. REMOVAL OF EXISTING PAVEMENT MARKING, WHEN REQUIRED, SHALL BE PAID FOR AS "PAVEMENT MARKING REMOVAL".
11. EXISTING OR TEMPORARY PAVEMENT MARKINGS REMOVED DURING MILLING OPERATIONS WILL NOT BE PAID FOR SEPARATELY.
12. CASTINGS EXPOSED IN TRAVEL LANES SHALL BE PROTECTED PER APPLICABLE PORTIONS OF ARTICLE 603.07 OF THE STANDARD SPECIFICATIONS. THIS WORK WILL NOT BE PAID FOR SEPARATELY, BUT SHALL BE INCLUDED IN THE VARIOUS HMA BINDER AND SURFACE COURSES PLACED.

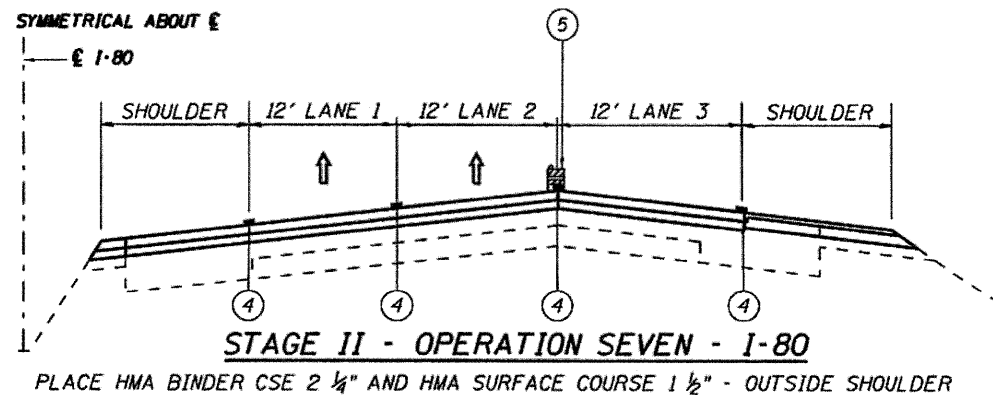
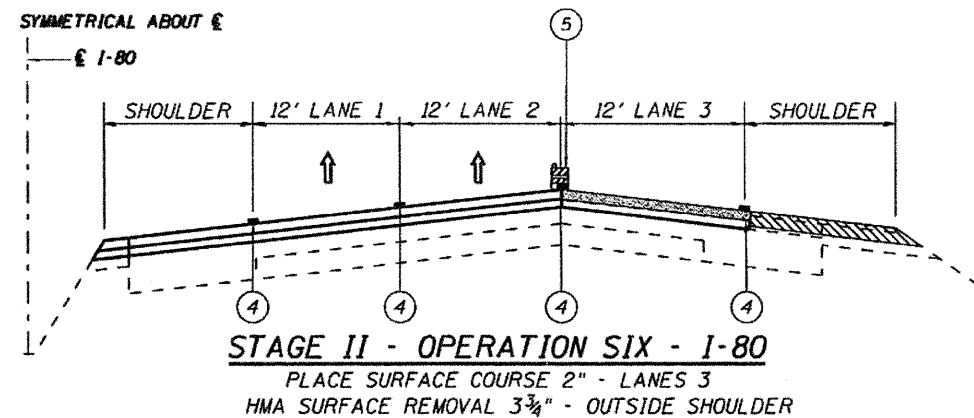
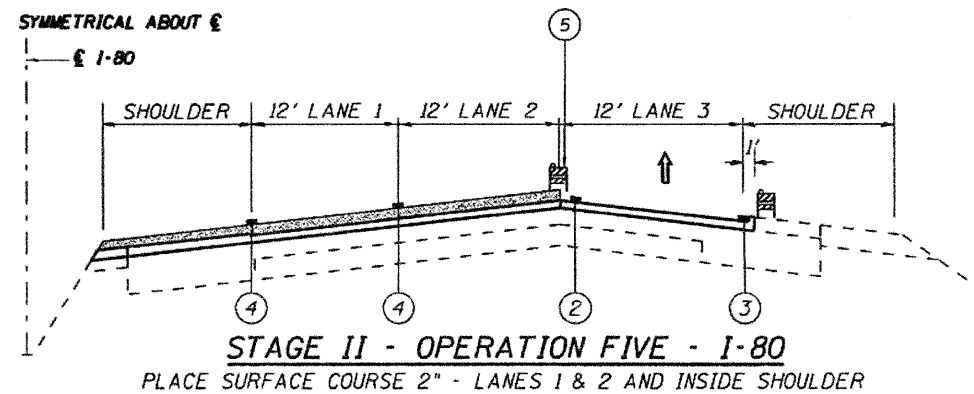
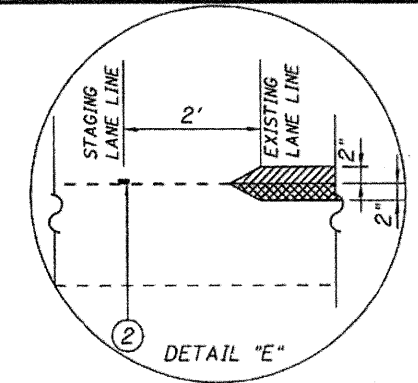
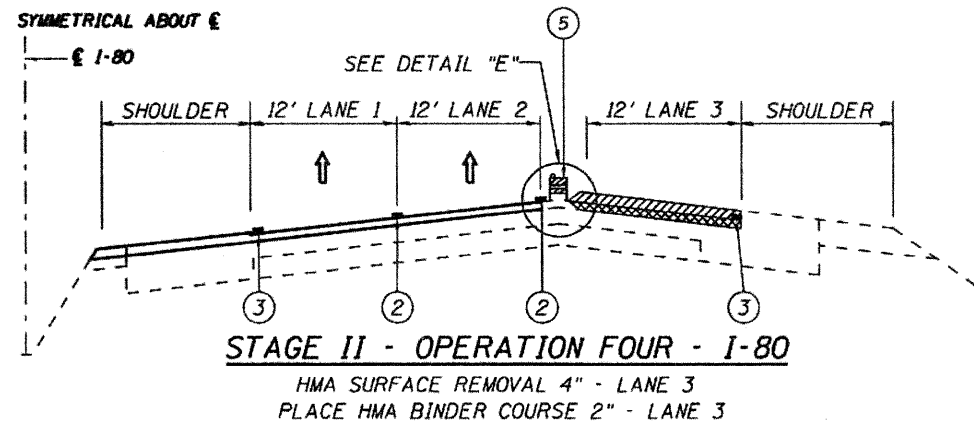

LEGEND

- ① EXISTING PAVEMENT MARKING
 - ② WET REFLECTIVE TEMPORARY TAPE, * TYPE III, 5" (10' DASH - 30' SKIP)
 - ③ WET REFLECTIVE TEMPORARY TAPE, TYPE III, 4" * (YELLOW LEFT & WHITE RIGHT) INSTALLED WITHIN 24 HOURS OF MILLING OR BINDER PLACEMENT.
 - ④ PROPOSED PAVEMENT MARKING. SEE PAVEMENT MARKING PLANS.
 - ⑤ VERTICAL BARRICADES WITH STEADY BURNING MONO DIRECTIONS LIGHT AT 100' C-C SPACING.
- * - USE TEMPORARY EPOXY PAVEMENT MARKING ON MILLED SURFACE

LONCO, INC.
CONSULTING ENGINEERS
1540 WALL ST. SUITE 222
HAMBURG, ILLINOIS 60563 PH: (630) 517-9100

DESIGNED - MJY	REVISED -
DRAWN - TS, ST, SV	REVISED -
CHECKED - MJY	REVISED -
DATE - 07/08/2009	REVISED -

**STATE OF ILLINOIS
DEPARTMENT OF TRANSPORTATION**

**SUGGESTED MAINTENANCE OF TRAFFIC
I-80 (EAST OF 80th AVE. TO I-294)**

SCALE: NONE SHEET NO. 3 OF 3 SHEETS STA. 81+61 TO STA. 427+00

F.A.I. RTE.	SECTION	COUNTY	TOTAL SHEETS	SHEET NO.
80	(95-5-1, ETC, 1819-824) RS-2	WILL & COOK	80	27
C-91-145-09			CONTRACT NO. 60F61	
FED. ROAD DIST. NO. [ILLINOIS] FED. AID PROJECT				