

OPTION 1

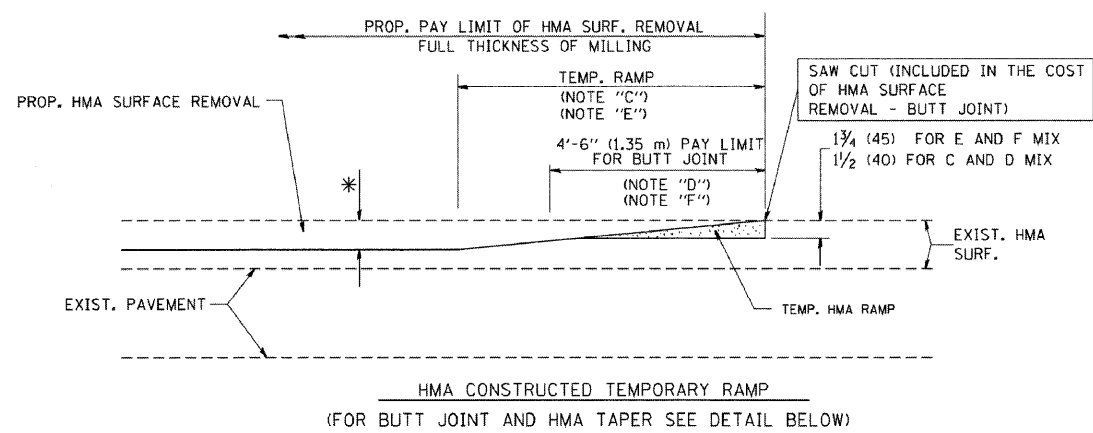

**OPTION 2
TYPICAL TEMPORARY RAMP**

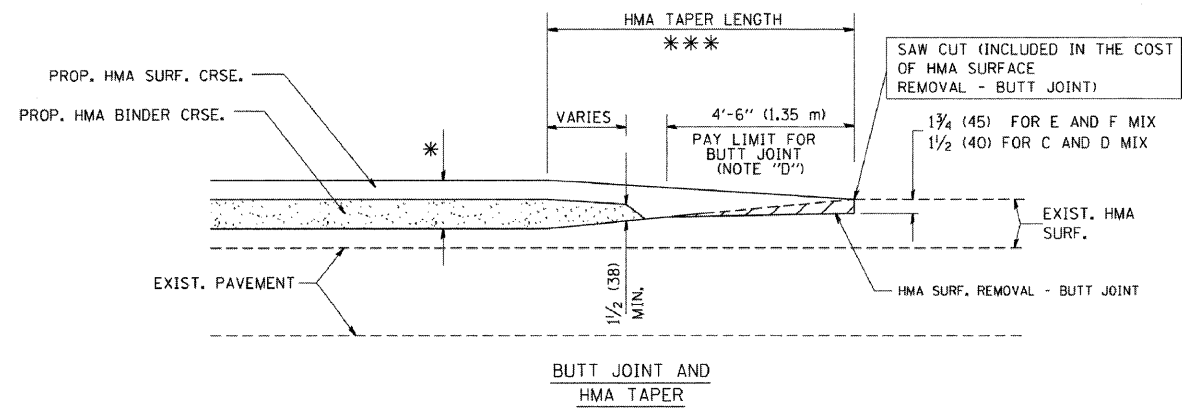

**TYPICAL BUTT JOINT AND HMA TAPER
FOR MILLING AND RESURFACING**

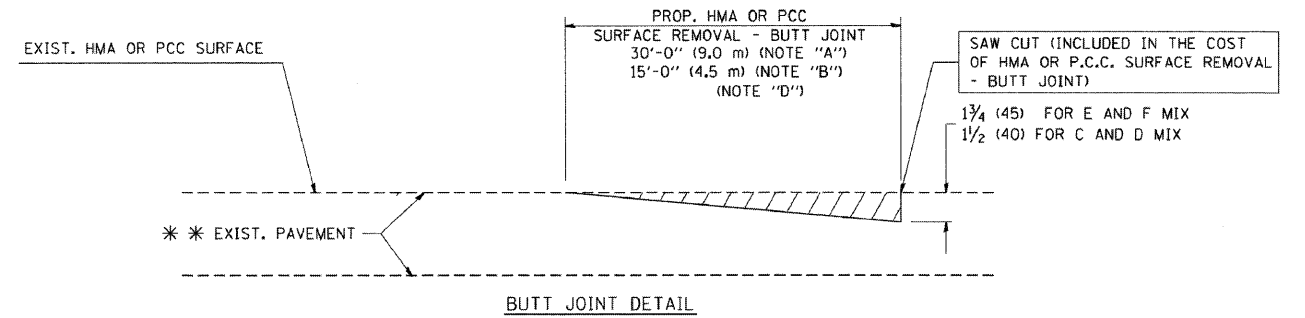

BUTT JOINT DETAIL

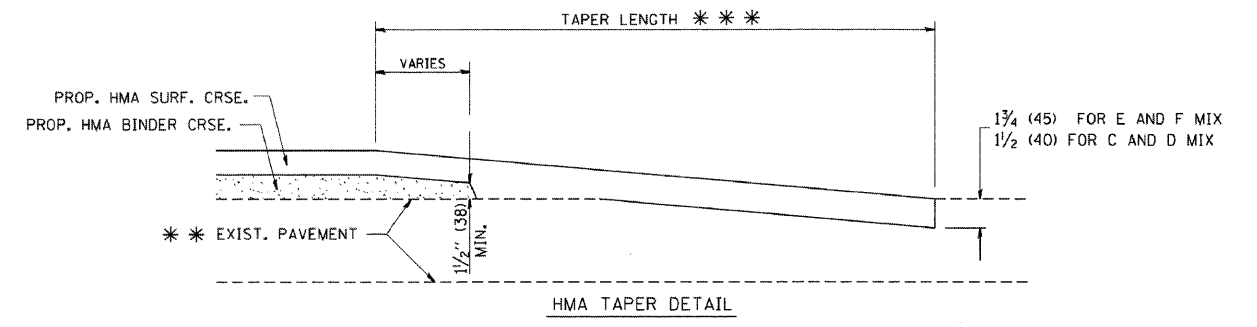

HMA TAPER DETAIL

**TYPICAL BUTT JOINT AND HMA TAPER
FOR RESURFACING ONLY**

*** PC CONCRETE, HMA OR HMA RESURFACED PAVEMENT.

NOTES

- A: MAINLINE ROADWAYS AND MAJOR SIDE ROADS.
 - B: MINOR SIDE ROADS.
 - C: THE TEMP. RAMP SHALL BE CONSTRUCTED IMMEDIATELY UPON REMOVAL OF THE EXISTING HMA SURFACE.
 - D: THE BUTT JOINT SHALL BE CONSTRUCTED IMMEDIATELY PRIOR TO PLACING THE PROPOSED HMA COURSES.
 - E: TAPER THE TEMP. RAMP AT A RATE OF 3'-0" (900 mm) PER 1 INCH (25 mm) OF MILLING THICKNESS.
 - F: INSTALLATION AND REMOVAL OF THE 4'-6" (1.35 m) TEMP. RAMP IS INCLUDED IN COST OF HMA SURFACE REMOVAL - BUTT JOINT
 - G: SEE ARTICLE 406.08 AND 406.14 OF THE STANDARD SPECIFICATIONS FOR "HMA AND/OR PCC SURFACE REMOVAL, BUTT JOINT".
- * SEE TYPICAL SECTIONS FOR MILLING THICKNESS.
- *** 20'-0" (6.1 m) PER 1 (25) RESURFACING (NOTE "A")
10'-0" (3.0 m) PER 1 (25) RESURFACING (NOTE "B")

ALL DIMENSIONS ARE IN INCHES (MILLIMETERS) UNLESS OTHERWISE SHOWN.

BASIS OF PAYMENT:

THE BUTT JOINT WILL BE PAID FOR AT THE CONTRACT UNIT PRICE PER SQUARE YARD (SQUARE METER) FOR "HOT-MIX ASPHALT SURFACE REMOVAL - BUTT JOINT" OR FOR "PORTLAND CEMENT CONCRETE SURFACE REMOVAL - BUTT JOINT".

BUTT JOINT AND HMA TAPER DETAILS

USER NAME = \$USER\$	DESIGNED - MJY	REVISIONS
DRAWN - RJG	REVISIONS	
CHECKED - MJY	REVISIONS	
DATE - 07/08/2009	REVISIONS	
PLOT SCALE = \$SCALE\$		
PLOT DATE = \$DATE\$		

DISTRICT ONE DETAIL SHEETS IL ROUTE 58 (GOLF ROAD)		
SCALE: NONE	SHEET NO. 28 OF 33 SHEETS	STA. 492+55 TO STA. 498+45

F.A.U. RTE. 1320	SECTION 581 B-1	COUNTY COOK	TOTAL SHEETS 33	SHEET NO. 28
D-91-288-09			CONTRACT NO. 60F91	
FED. ROAD DIST. NO. [ILLINOIS] FED. AID PROJECT				