

F.A.U. RTE.	SECTION	COUNTY	TOTAL SHEETS	SHEET NO.
2907	1Y (5,6 & 7) RS	COOK	17	1
FED. ROAD DIST. NO. 1		ILLINOIS	CONTRACT NO. 62404	

STATE OF ILLINOIS
DEPARTMENT OF TRANSPORTATION

DIVISION OF HIGHWAYS

**PROPOSED
HIGHWAY PLANS**

F.A.U. 2907 (STATE STREET)
SECTION: 1Y (5,6 & 7) RS
69TH STREET TO 60TH STREET
RESURFACING (3P)

PROJECT: *ESP-2907(002)*
COOK COUNTY
C-91-086-02

FOR INDEX OF SHEETS, SEE SHEET NO. 2

THESE IMPROVEMENTS ARE LOCATED
WITHIN THE CITY OF CHICAGO

TRAFFIC DATA

2004 ADT - 15,100
POSTED SPEED LIMIT - 30 MPH

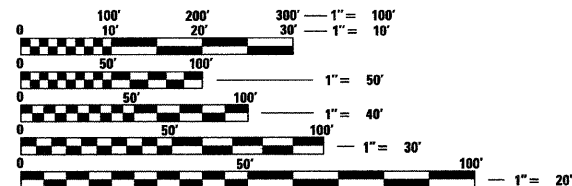

FULL SIZE PLANS HAVE BEEN PREPARED USING STANDARD ENGINEERING SCALES. REDUCED SIZED PLANS WILL NOT CONFORM TO STANDARD SCALES. IN MAKING MEASUREMENTS ON REDUCED PLANS, THE ABOVE SCALES MAY BE USED.

J.U.L.I.E.
JOINT UTILITY LOCATION INFORMATION FOR EXCAVATION
1-800-892-0123
OR 811

Giorba Group, Inc.

DESIGN FIRM
REGISTRATION NUMBER
184-001016
CONSULTING ENGINEERS
SUITE 402, 5507 NORTH CUMBERLAND AVE
CHICAGO, ILLINOIS 60656 ☎ (773) 775-4009

LOCATION MAP
1" = 2,000'

GROSS & NET LENGTH OF PROJECT = 6,061 FT = 1.15 MI.

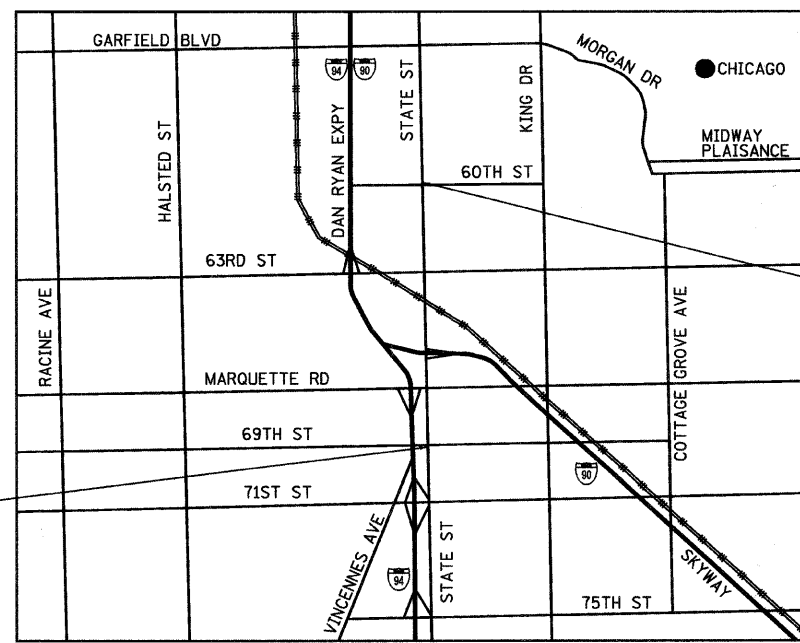

BEGIN PROJECT
STA. 11 + 43

END PROJECT
STA. 72 + 04

D-91-086-02



LOCATION OF SECTION INDICATED THUS: - [thick black line] -

STATE OF ILLINOIS
DEPARTMENT OF TRANSPORTATION
DIVISION OF HIGHWAYS

SUBMITTED June 24, 20 09
Di O'Neil
DEPUTY DIRECTOR OF HIGHWAYS, REGION ENGINEER
August 14, 20 09
Charles J. Ingersoll
ENGINEER OF DESIGN AND ENVIRONMENT
August 14, 20 09
Christie M. Reed
DIRECTOR OF HIGHWAYS, CHIEF ENGINEER

PRINTED BY THE AUTHORITY
OF THE STATE OF ILLINOIS

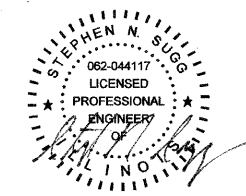

DATE: 6/23/2009
SEAL EXPIRES: 11/30/2009

DISTRICT 1 DESIGN PLAN PREPARATION ENGINEER: K. ENG (847)705-4247

CONTRACT NO. 62404

INDEX OF SHEETS

SHEET NO	DESCRIPTION
1	COVER SHEET
2	INDEX OF SHEETS, STATE STANDARDS AND GENERAL NOTES
3	SUMMARY OF QUANTITIES
4	TYPICAL SECTIONS
5-7	PROPOSED ROADWAY AND PAVEMENT MARKING PLAN
8	DETAILS FOR FRAMES AND LIDS ADJUSTMENT WITH MILLING (BD-8)
9	CITY OF CHICAGO DETAILS FOR P.C. CONCRETE DRIVEWAY, ALLEY RETURN AND SIDEWALK (BD-17)
10	PAVEMENT PATCHING FOR HMA SURFACED PAVEMENT (BD-22)
11	CURB AND GUTTER REMOVAL AND REPLACEMENT (BD-24)
12	BUTT JOINT AND HMA TAPER DETAILS (BD-32)
13	TRAFFIC CONTROL AND PROTECTION FOR SIDE ROADS, INTERSECTIONS, AND DRIVEWAYS (TC-10)
14	TRAFFIC CONTROL AND PROTECTION AT TURN BAYS (TO REMAIN OPEN TO TRAFFIC) (TC-14)
14A	PAVEMENT MARKING LETTERS AND SYMBOLS FOR TRAFFIC STAGING (TC-16)
15	ARTERIAL ROAD INFORMATION SIGN (TC-22)
16-17	CITY OF CHICAGO TYPICAL PAVEMENT MARKINGS (TC-24)

STATE STANDARDS

000001-05	STANDARD SYMBOLS, ABBREVIATIONS, AND PATTERNS
442201-03	CLASS C AND D PATCHES
602401-02	MANHOLE TYPE A
602601-02	PRECAST REINFORCED CONCRETE FLAT SLAB TOP
604001-03	FRAME AND LIDS, TYPE 1
642001-01	CONCRETE CURB TYPE B AND COMBINATION CONCRETE CURB AND GUTTER
701501-05	URBAN LANE CLOSURE, 2L, 2W, UNDIVIDED
701601-06	URBAN LANE CLOSURE, MULTILANE, 1W OR 2W WITH NONTRAVERSABLE MEDIAN
701606-06	URBAN LANE CLOSURE, MULTILANE, 2W WITH MOUNTABLE MEDIAN
701701-06	URBAN LANE CLOSURE, MULTI LANE INTERSECTION
701801-04	LANE CLOSURE MULTILANE 1W, 2W, CROSSWALK OR SIDEWALK CLOSURE
701901-01	TRAFFIC CONTROL DEVICES
780001-02	TYPICAL PAVEMENT MARKINGS

GENERAL NOTES

- BEFORE STARTING ANY EXCAVATION, THE CONTRACTOR SHALL CALL "JULIE" AT 800-892-0123 OR 811 FOR FIELD LOCATIONS OF BURIED ELECTRIC, TELEPHONE, AND GAS FACILITIES. (48 HOUR NOTIFICATION IS REQUIRED)
- 10 FEET (3 METER) TRANSITIONS SHALL BE USED TO MATCH PROPOSED CURB AND GUTTER AND MEDIAN ITEMS OF WORK TO EXISTING CURB AND GUTTER AND MEDIANS IN THE FIELD UNLESS OTHERWISE SHOWN. THE TRANSITIONS SHALL BE PAID FOR AT THE CONTRACT UNIT PRICE FOR THE PROPOSED ITEMS OF WORK SPECIFIED.
- THE CONTRACTOR SHALL COORDINATE CONSTRUCTION ACTIVITIES WITH UTILITY COMPANIES.
- THE CONTRACTOR WILL NOT BE ALLOWED TO SET UP A YARD OR FIELD OFFICE ON STATE PROPERTY WITHOUT WRITTEN PERMISSION FROM THE DEPARTMENT.
- WHEN ARTIFICIAL LIGHTING IS USED IN NIGHT OPERATIONS THE CONTRACTOR SHALL EXERCISE THE UTMOST PRECAUTIONS IN PREVENTING ADVERSE VISIBILITY TO THE MOTORING PUBLIC AND ADJOINING RESIDENTIAL AREAS.
- THE FOLLOWING RATES OF APPLICATION HAVE BEEN ASSUMED IN CALCULATING PLAN QUANTITIES:

BITUMINOUS MATERIALS (PRIME COAT) 0.0004 TONS/SQ YD
- THE ENGINEER SHALL CONTACT THE TRAFFIC CONTROL SUPERVISORS AT (847) 705-4470 A MINIMUM OF 72 HOURS PRIOR TO THE START OF WORK.
- TWO WEEKS PRIOR TO PLACEMENT OF PERMANENT PAVEMENT MARKINGS THE RESIDENT ENGINEER SHALL CONTACT PATRICE HARRIS, AREA TRAFFIC FIELD TECHNICIAN, AT (773) 597-9800.
- WHEN MILLED PAVEMENT IS OPEN TO TRAFFIC THE MAXIMUM GRADE DIFFERENTIAL BETWEEN PASSES OF THE MILLING MACHINE SHALL NOT EXCEED 1 1/2" (40 MM) WHERE THE SPEED LIMIT IS 45 MPH (80 KM/H) OR LESS AND 1" (25 MM) WHERE THE SPEED LIMIT IS GREATER THAN 45 MPH (80 KM/H). WITH WRITTEN APPROVAL FROM THE ENGINEER, A MAXIMUM GRADE DIFFERENTIAL OF 3" (75 MM) MAY BE ALLOWED IF THE EDGE OF THE MILLING IS SLOPED A MINIMUM 3:1 (H:V).
- BUTT JOINTS WILL BE INSTALLED AT THE END OF ALL RESURFACING (WHERE RESURFACING MEETS EXISTING PAVEMENT). IN ACCORDANCE WITH THE "BUTT JOINT AND HMA TAPER DETAILS" SHEET INCLUDED IN THE PLANS, UNLESS OTHERWISE SPECIFIED.
- FOR PAVEMENT MARKING, REFER TO CITY OF CHICAGO TYPICAL MARKINGS FOR DETAILS SHOWN.
- MATCH EXISTING PAVEMENT MARKINGS AT PROJECT LIMITS.
- ALL PATCHES OPENED ON A PARTICULAR DAY MUST BE FILLED THAT DAY TO THE PAVED SURFACE.

- CONTINGENCY QUANTITIES HAVE BEEN INCLUDED FOR THE FOLLOWING ITEMS TO BE USED AT THE DIRECTION OF THE ENGINEER:

60406000 FRAMES AND LIDS, TYPE 1, OPEN LID - 15 EACH
60406100 FRAMES AND LIDS, TYPE 1, CLOSED LID - 15 EACH
- NO OVERNIGHT LANE CLOSURES SHALL BE ALLOWED.

FILE NAME = N:\PROJECTS\35868\35868_2\Design\ProposedPlan\35868_2n-02-General Notes.dgn



Ciorba Group, Inc.
CONSULTING ENGINEERS
5507 North Cumberland Avenue, Suite 402
Chicago, Illinois 60656
Tel. 773.775.4009 Fax 773.775.4014

USER NAME = wlcoster	DESIGNED - MWR	REVISED -
	DRAWN - MWR	REVISED -
PLOT SCALE = 1:2000' / IN.	CHECKED - SNS	REVISED -
PLOT DATE = 7/17/2009	DATE - 6/24/2009	REVISED -

**STATE OF ILLINOIS
DEPARTMENT OF TRANSPORTATION**

**STATE STREET
69TH STREET TO 60TH STREET
INDEX OF SHEETS, STATE STANDARDS & GENERAL NOTES**

SCALE: SHEET NO. OF SHEETS STA. TO STA.

F.A.U. RTE.	SECTION	COUNTY	TOTAL SHEETS	SHEET NO.
2907	1Y (5,6 & 7) RS	COOK	17	2
FED. ROAD DIST. NO. 1 ILLINOIS FED. AID PROJECT			CONTRACT NO. 62404	

SUMMARY OF QUANTITIES				URBAN 100% FED.	CONSTRUCTION TYPE CODE
CODE NO.	DESCRIPTION	UNIT	TOTAL QUANTITY		ROADWAY 1000-2A
40201000	AGGREGATE FOR TEMPORARY ACCESS	TON	10		10
40600200	BITUMINOUS MATERIALS (PRIME COAT)	TON	40		40
40600300	AGGREGATE (PRIME COAT)	TON	190		190
40600400	MIXTURE FOR CRACKS, JOINTS, AND FLANGEWAYS	TON	6		6
40600535	LEVELING BINDER (HAND METHOD), N70	TON	10		10
40600895	CONSTRUCTING TEST STRIP	EACH	2		2
40600982	HOT-MIX ASPHALT SURFACE REMOVAL - BUTT JOINT	SQ YD	588		588
40601005	HOT-MIX ASPHALT REPLACEMENT OVER PATCHES	TON	330		330
40603340	HOT-MIX ASPHALT SURFACE COURSE, MIX "D", N70	TON	4,000		4,000
42300400	PORTLAND CEMENT CONCRETE DRIVEWAY PAVEMENT, 8 INCH	SQ YD	10		10
42400300	PORTLAND CEMENT CONCRETE SIDEWALK 6 INCH	SQ FT	1,500		1,500
44000158	HOT-MIX ASPHALT SURFACE REMOVAL, 2 1/4"	SQ YD	47,000		47,000
44000200	DRIVEWAY PAVEMENT REMOVAL	SQ YD	10		10
44000600	SIDEWALK REMOVAL	SQ FT	1,500		1,500
44001700	COMBINATION CONCRETE CURB AND GUTTER REMOVAL AND REPLACEMENT	FOOT	600		600
44002212	HOT-MIX ASPHALT REMOVAL OVER PATCHES, 3"	SQ YD	1,950		1,950
44003510	MEDIAN REMOVAL PARTIAL DEPTH	SQ FT	1,520		1,520
44201765	CLASS D PATCHES, TYPE II, 10 INCH	SQ YD	390		390
44201769	CLASS D PATCHES, TYPE III, 10 INCH	SQ YD	610		610
44201771	CLASS D PATCHES, TYPE IV, 10 INCH	SQ YD	680		680
NP 55039700	STORM SEWERS TO BE CLEANED	FOOT	1,900		1,900
60257900	MANHOLES TO BE RECONSTRUCTED	EACH	1		1
60300305	FRAMES AND LIDS TO BE ADJUSTED	EACH	10		10
60300310	FRAMES AND LIDS TO BE ADJUSTED (SPECIAL)	EACH	170		170
60406000	FRAMES AND LIDS, TYPE 1, OPEN LID	EACH	15		15
60406100	FRAMES AND LIDS, TYPE 1, CLOSED LID	EACH	15		15
67000400	ENGINEER'S FIELD OFFICE, TYPE A	CAL MO	6		6
67100100	MOBILIZATION	L SUM	1		1
70102620	TRAFFIC CONTROL AND PROTECTION, STANDARD 701501	L SUM	1		1
70102625	TRAFFIC CONTROL AND PROTECTION, STANDARD 701606	L SUM	1		1
70102630	TRAFFIC CONTROL AND PROTECTION, STANDARD 701601	L SUM	1		1
20048665 RAILROAD PROTECTIVE LIABILITY INSURANCE			L SUM	1	1

* DENOTES SPECIALTY ITEM

SUMMARY OF QUANTITIES				URBAN 100% FED.	CONSTRUCTION TYPE CODE
CODE NO.	DESCRIPTION	UNIT	TOTAL QUANTITY		ROADWAY 1000-2A
70102635	TRAFFIC CONTROL AND PROTECTION, STANDARD 701701	L SUM	1		1
70102640	TRAFFIC CONTROL AND PROTECTION, STANDARD 701801	L SUM	1		1
70300100	SHORT-TERM PAVEMENT MARKING	FOOT	7,280		7,280
70300210	TEMPORARY PAVEMENT MARKING - LETTERS AND SYMBOLS	SQ FT	3,500		3,500
70300220	TEMPORARY PAVEMENT MARKING - LINE 4"	FOOT	25,800		25,800
70300240	TEMPORARY PAVEMENT MARKING - LINE 6"	FOOT	19,200		19,200
70300260	TEMPORARY PAVEMENT MARKING - LINE 12"	FOOT	8,400		8,400
70300280	TEMPORARY PAVEMENT MARKING - LINE 24"	FOOT	2,700		2,700
70301000	WORK ZONE PAVEMENT MARKING REMOVAL	SQ FT	11,900		11,900
* 78000100	THERMOPLASTIC PAVEMENT MARKING - LETTERS AND SYMBOLS	SQ FT	1,150		1,150
* 78000200	THERMOPLASTIC PAVEMENT MARKING - LINE 4"	FOOT	17,900		17,900
* 78000400	THERMOPLASTIC PAVEMENT MARKING - LINE 6"	FOOT	6,400		6,400
* 78000600	THERMOPLASTIC PAVEMENT MARKING - LINE 12"	FOOT	2,800		2,800
* 78000650	THERMOPLASTIC PAVEMENT MARKING - LINE 24"	FOOT	900		900
X0322256	TEMPORARY INFORMATION SIGNING	SQ FT	51		51
X4067107	POLYMERIZED LEVELING BINDER (MACHINE METHOD), IL-4.75, N50	TON	1,860		1,860
NP Z0018500	DRAINAGE STRUCTURES TO BE CLEANED	EACH	180		180

@ 20076600 TRAINEES HOUR 500 500

@ Y080

NP = Non-participating

FILE NAME = N:\PROJ\3368\29\Design\Proposed\Plan\3368_29\92-Quantities.dgn

Ciorba Group, Inc.
CONSULTING ENGINEERS
5507 North Cumberland Avenue, Suite 402
Chicago, Illinois 60655
Tel. 773.775.4099 Fax 773.775.4014

USER NAME = mready	DESIGNED - MWR	REVISED -
PLOT SCALE = 1:8000' / 1" IN.	DRAWN - MWR	REVISED -
PLOT DATE = 6/24/2009	CHECKED - SNS	REVISED -
	DATE - 6/24/2009	REVISED -

**STATE OF ILLINOIS
DEPARTMENT OF TRANSPORTATION**

**STATE STREET
69TH STREET TO 60TH STREET
SUMMARY OF QUANTITIES**

SCALE: SHEET NO. OF SHEETS STA. TO STA.

F.A.U. RTE. 2907	SECTION 1Y (5.6 & 7) RS	COUNTY COOK	TOTAL SHEETS 17	SHEET NO. 3
FED. ROAD DIST. NO. 1 ILLINOIS FED. AID PROJECT			CONTRACT NO. 62404	

Rev.

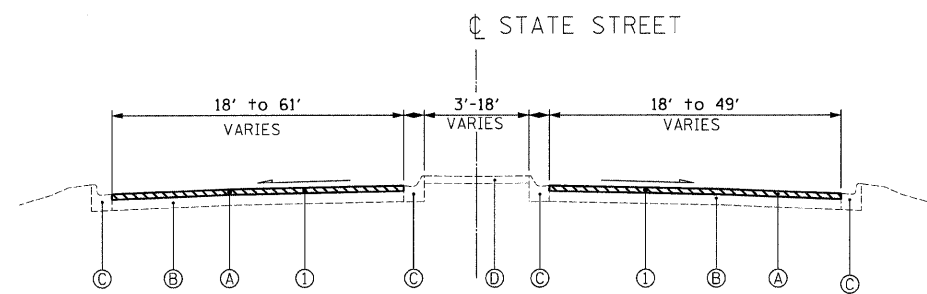

EXISTING TYPICAL SECTION
STA. 11+43 TO STA. 34+30
STA. 45+82 TO STA. 51+23

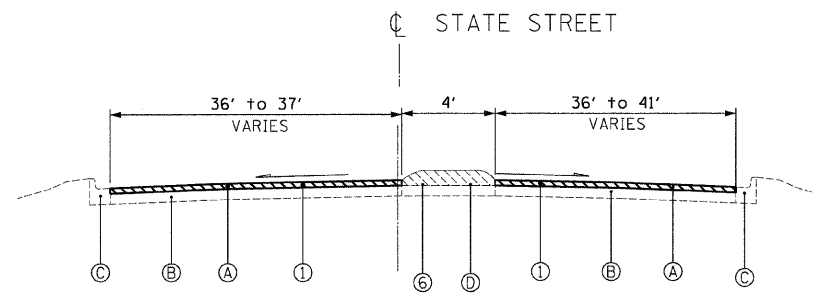

EXISTING TYPICAL SECTION
STA. 34+30 TO STA. 38+09

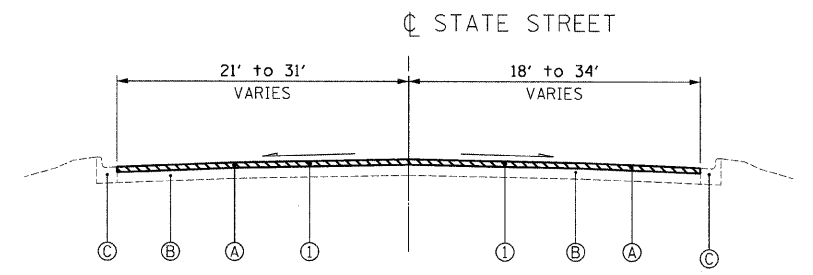

EXISTING TYPICAL SECTION
STA. 38+09 TO STA. 45+82
STA. 51+23 TO STA. 72+04

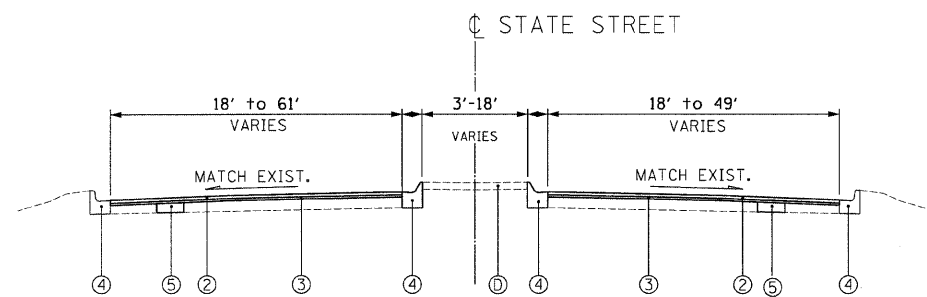

PROPOSED TYPICAL SECTION
STA. 11+43 TO STA. 34+30
STA. 45+82 TO STA. 51+23

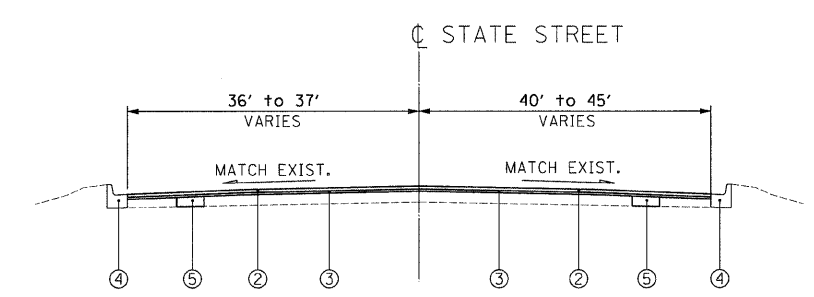

PROPOSED TYPICAL SECTION
STA. 34+30 TO STA. 38+09

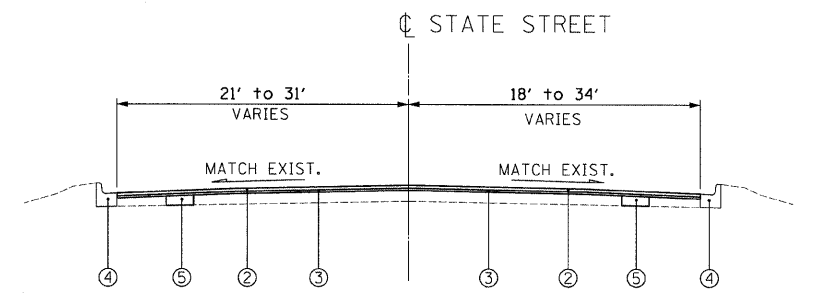

PROPOSED TYPICAL SECTION
STA. 38+09 TO STA. 45+82
STA. 51+23 TO STA. 72+04

EXISTING CONDITIONS:

- (A) HOT-MIX ASPHALT SURFACE AND BINDER COURSE, 3" AND VARIES
- (B) PORTLAND CEMENT CONCRETE BASE COURSE, 10" +/-
- (C) COMBINATION CONCRETE CURB AND GUTTER
- (D) RAISED PORTLAND CEMENT CONCRETE MEDIAN

PROPOSED IMPROVEMENTS:

- (1) HOT-MIX ASPHALT SURFACE REMOVAL, 2 1/4"
- (2) HOT-MIX ASPHALT SURFACE COURSE, MIX "D", N70, 1 1/2"
- (3) POLYMERIZED LEVELING BINDER (MACHINE METHOD), IL-4.75, N50, 3/4"
- (4) COMBINATION CONCRETE CURB AND GUTTER REMOVAL AND REPLACEMENT (AS DIRECTED BY ENGINEER)
- (5) CLASS D PATCHES, 10" (DETERMINED BY ENGINEER IN FIELD)
- (6) MEDIAN REMOVAL PARTIAL DEPTH, 4"

A QUANTITY FOR LEVELING BINDER (HAND METHOD) HAS BEEN PROVIDED FOR USE AT PRIVATE ENTRANCES, AROUND HAND HOLES, PRIVATE UTILITY STRUCTURE FRAMES, AND ANY OTHER STRUCTURE FRAMES THAT ARE NOT ABLE TO BE LOWERED UNDER THE ITEM "FRAMES AND LIDS TO BE ADJUSTED (SPECIAL)" AFTER GRINDING OF EXISTING PAVEMENT.

HOT-MIX ASPHALT MIXTURE REQUIREMENTS CHART

OPERATIONS	MIXTURE TYPE	AC TYPE	PERCENT AIR VOIDS
ROADWAY RESURFACING	HOT-MIX ASPHALT SURFACE COURSE, MIX "D", N70 (IL-9.5MM)	PG 64-22	4% @ 70 GYR
	POLYMERIZED LEVELING BINDER (MACHINE METHOD), IL-4.75, N50	SBS/SBR PG 76-28/-22	4% @ 50 GYR
INCIDENTAL USE	LEVELING BINDER (HAND METHOD), N70 (IL-9.5MM)	PG 64-22 *	4% @ 70 GYR
PAVEMENT PATCHING	CLASS D PATCHES, 10" (HMA BINDER IL-19 MM)	PG 64-22 *	4% @ 70 GYR
	HOT-MIX ASPHALT REPLACEMENT OVER PATCHES (HMA BINDER IL-19 MM)	PG 64-22 *	4% @ 70 GYR

THE UNIT WEIGHT USED TO CALCULATE ALL HMA SURFACE MIXTURE QUANTITIES IS 112 LBS/SQ YD/IN.

* WHEN RAP EXCEEDS 20%, THE NEW ASPHALT BINDER IN THE MIX SHALL BE PG 58-22.

FILE NAME = N:\PROJ\3368\3368_29\Design\Proposed\Plan\3368_29_04_Typical Sections.dgn

Ciorba Group, Inc.
CONSULTING ENGINEERS
5507 North Cumberland Avenue, Suite 402
Chicago, Illinois 60656
Tel. 773.775.4009 Fax 773.775.4014

USER NAME = mready	DESIGNED - MWR	REVISED -
PLOT SCALE = 5/8" = 1' IN.	DRAWN - MWR	REVISED -
PLOT DATE = 6/24/2009	CHECKED - SNS	REVISED -
	DATE - 6/24/2009	REVISED -

**STATE OF ILLINOIS
DEPARTMENT OF TRANSPORTATION**

**STATE STREET
69TH STREET TO 60TH STREET
TYPICAL SECTIONS**

SCALE: N.T.S. SHEET NO. OF SHEETS STA. TO STA.

F.A.U. RTE. 2907	SECTION 1Y (5, 6 & 7) RS	COUNTY COOK	TOTAL SHEETS 17	SHEET NO. 4
CONTRACT NO. 62404				
FED. ROAD DIST. NO. 1 ILLINOIS FED. AID PROJECT				

LEGEND:

- 1 THERMOPLASTIC PAVEMENT MARKING - LINE 4" (DOUBLE YELLOW SOLID LINE 8" C-C)
- 2 THERMOPLASTIC PAVEMENT MARKING - LINE 4" (YELLOW SOLID LINE)
- 3 THERMOPLASTIC PAVEMENT MARKING - LINE 4" (WHITE LANE LINE - 6' DASH, 18' SKIP)
- 4 THERMOPLASTIC PAVEMENT MARKING - LINE 4" (WHITE SOLID LINE)
- 5 THERMOPLASTIC PAVEMENT MARKING - LINE 4" (YELLOW LINE - 6' DASH, 18' SKIP)
- 6 THERMOPLASTIC PAVEMENT MARKING - LINE 6" (WHITE LANE LINE - 2' DASH, 6' SKIP)

- 7 THERMOPLASTIC PAVEMENT MARKING - LINE 6" (WHITE SOLID LINE)
- 8 THERMOPLASTIC PAVEMENT MARKING - LINE 12" (YELLOW DIAGONAL LINE)
- 9 THERMOPLASTIC PAVEMENT MARKING - LINE 12" (WHITE DIAGONAL LINE)
- 10 THERMOPLASTIC PAVEMENT MARKING - LINE 24" (WHITE STOP LINE)
- 11 THERMOPLASTIC PAVEMENT MARKING - LETTERS AND SYMBOLS (TYP.)

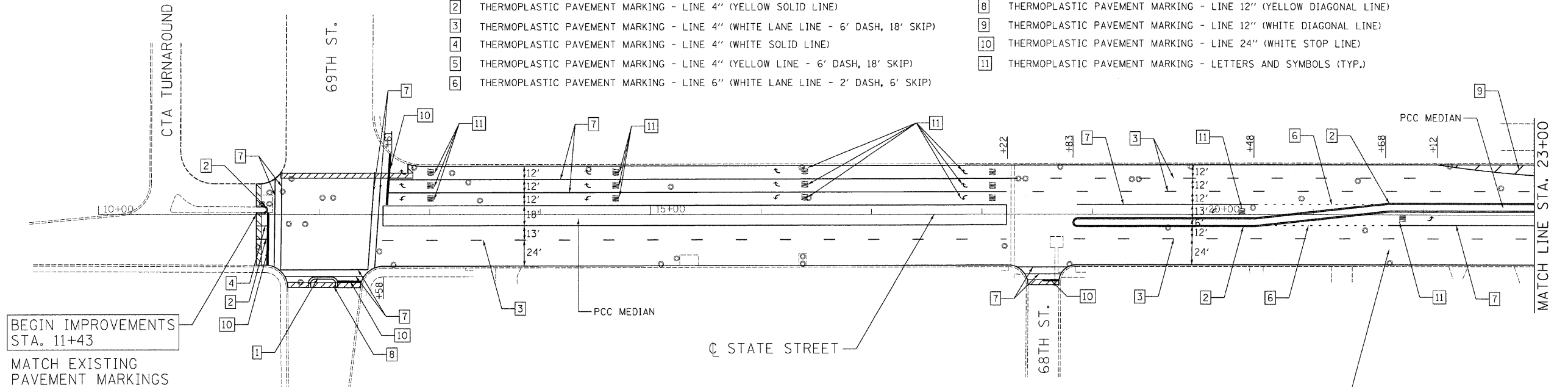

HOT-MIX ASPHALT SURFACE REMOVAL - BUTT JOINT

LEGEND:

- 1 THERMOPLASTIC PAVEMENT MARKING - LINE 4" (DOUBLE YELLOW SOLID LINE 8" C-C)
- 2 THERMOPLASTIC PAVEMENT MARKING - LINE 4" (YELLOW SOLID LINE)
- 3 THERMOPLASTIC PAVEMENT MARKING - LINE 4" (WHITE LANE LINE - 6' DASH, 18' SKIP)
- 4 THERMOPLASTIC PAVEMENT MARKING - LINE 4" (WHITE SOLID LINE)
- 5 THERMOPLASTIC PAVEMENT MARKING - LINE 4" (YELLOW LINE - 6' DASH, 18' SKIP)
- 6 THERMOPLASTIC PAVEMENT MARKING - LINE 6" (WHITE LANE LINE - 2' DASH, 6' SKIP)

- 7 THERMOPLASTIC PAVEMENT MARKING - LINE 6" (WHITE SOLID LINE)
- 8 THERMOPLASTIC PAVEMENT MARKING - LINE 12" (YELLOW DIAGONAL LINE)
- 9 THERMOPLASTIC PAVEMENT MARKING - LINE 12" (WHITE DIAGONAL LINE)
- 10 THERMOPLASTIC PAVEMENT MARKING - LINE 24" (WHITE STOP LINE)
- 11 THERMOPLASTIC PAVEMENT MARKING - LETTERS AND SYMBOLS (TYP.)

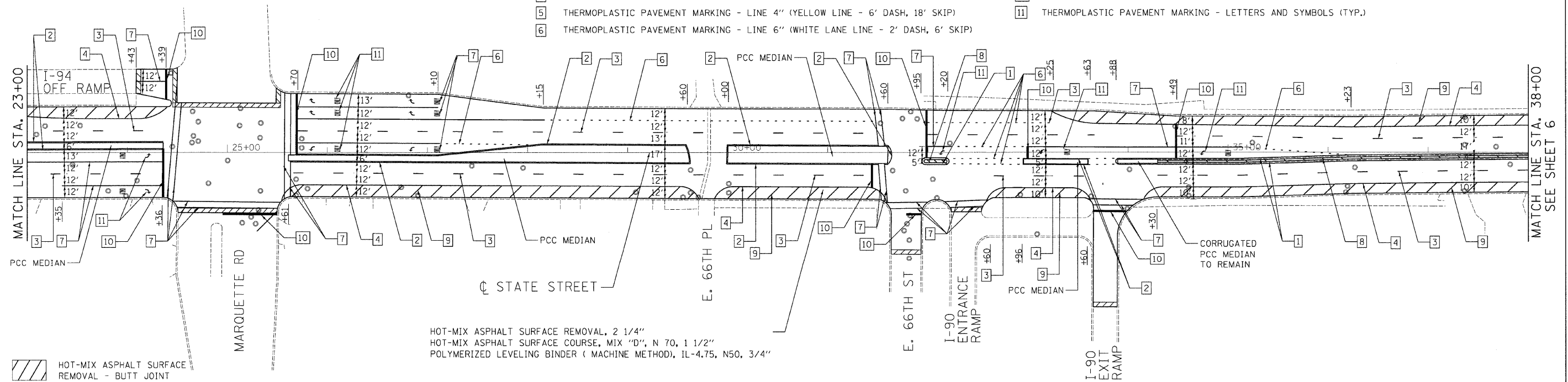

HOT-MIX ASPHALT SURFACE REMOVAL - BUTT JOINT

FILE NAME = r:\p\p\3368\3368_29\design\proposals\3368_29\Prop01.dgn

CG Ciorba Group, Inc.
CONSULTING ENGINEERS
5507 North Cumberland Avenue, Suite 402
Chicago, Illinois 60650
Tel. 773.775.4009 Fax 773.775.4014

USER NAME = wlocaester	DESIGNED - MWR	REVISED -
PLOT SCALE = 50.0000 "/>		

**STATE OF ILLINOIS
DEPARTMENT OF TRANSPORTATION**

**STATE STREET
69TH STREET TO 60TH STREET
PROPOSED ROADWAY AND PAVEMENT MARKING PLAN**

SCALE: 1"=50' SHEET NO. OF SHEETS STA. TO STA.

F.A.U. RTE. 2907	SECTION 1Y (5,6 & 7) RS	COUNTY COOK	TOTAL SHEETS 17	SHEET NO. 5
FED. ROAD DIST. NO. 1 ILLINOIS FED. AID PROJECT				CONTRACT NO. 62404

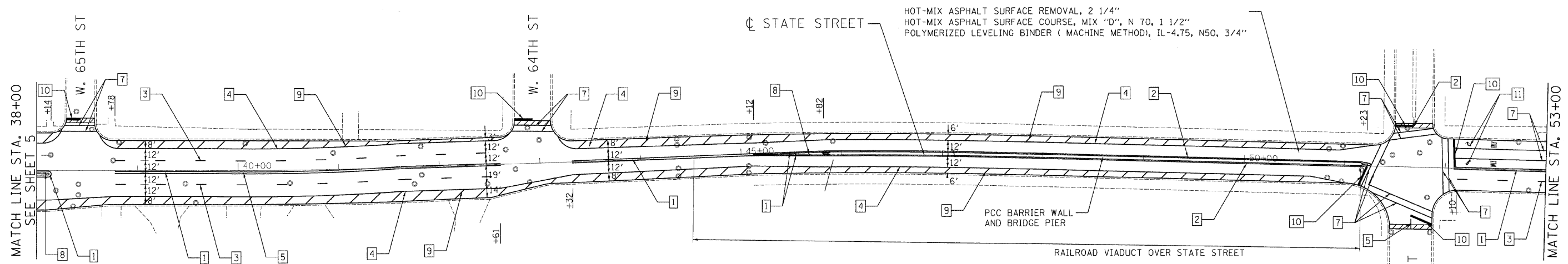

MATCH LINE STA. 38+00
SEE SHEET 5

MATCH LINE STA. 53+00

LEGEND:

- | | | | |
|---|--|----|--|
| 1 | THERMOPLASTIC PAVEMENT MARKING - LINE 4" (DOUBLE YELLOW SOLID LINE 8" C-C) | 7 | THERMOPLASTIC PAVEMENT MARKING - LINE 6" (WHITE SOLID LINE) |
| 2 | THERMOPLASTIC PAVEMENT MARKING - LINE 4" (YELLOW SOLID LINE) | 8 | THERMOPLASTIC PAVEMENT MARKING - LINE 12" (YELLOW DIAGONAL LINE) |
| 3 | THERMOPLASTIC PAVEMENT MARKING - LINE 4" (WHITE LANE LINE - 6' DASH, 18' SKIP) | 9 | THERMOPLASTIC PAVEMENT MARKING - LINE 12" (WHITE DIAGONAL LINE) |
| 4 | THERMOPLASTIC PAVEMENT MARKING - LINE 4" (WHITE SOLID LINE) | 10 | THERMOPLASTIC PAVEMENT MARKING - LINE 24" (WHITE STOP LINE) |
| 5 | THERMOPLASTIC PAVEMENT MARKING - LINE 4" (YELLOW LINE - 6' DASH, 18' SKIP) | 11 | THERMOPLASTIC PAVEMENT MARKING - LETTERS AND SYMBOLS (TYP.) |
| 6 | THERMOPLASTIC PAVEMENT MARKING - LINE 6" (WHITE LANE LINE - 2' DASH, 6' SKIP) | | |

HOT-MIX ASPHALT SURFACE REMOVAL - BUTT JOINT

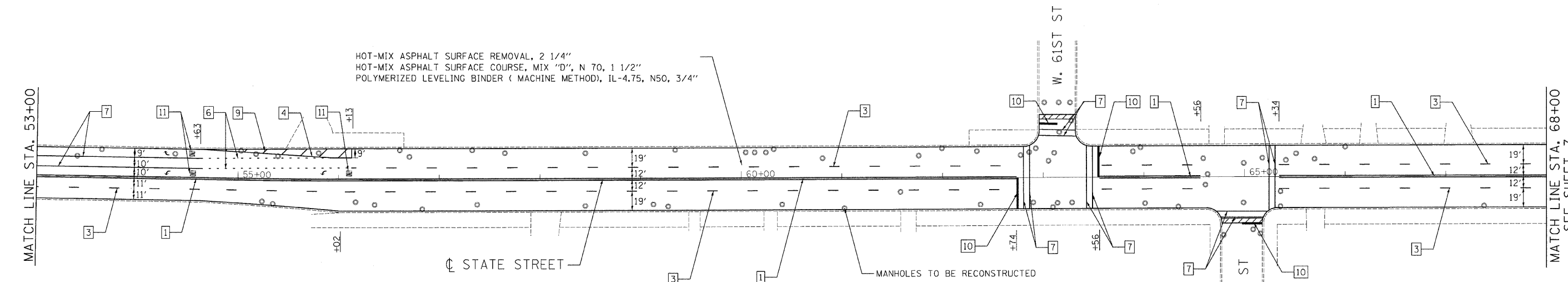
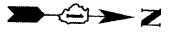

MATCH LINE STA. 53+00

MATCH LINE STA. 68+00
SEE SHEET 7

LEGEND:

- | | | | |
|---|--|----|--|
| 1 | THERMOPLASTIC PAVEMENT MARKING - LINE 4" (DOUBLE YELLOW SOLID LINE 8" C-C) | 7 | THERMOPLASTIC PAVEMENT MARKING - LINE 6" (WHITE SOLID LINE) |
| 2 | THERMOPLASTIC PAVEMENT MARKING - LINE 4" (YELLOW SOLID LINE) | 8 | THERMOPLASTIC PAVEMENT MARKING - LINE 12" (YELLOW DIAGONAL LINE) |
| 3 | THERMOPLASTIC PAVEMENT MARKING - LINE 4" (WHITE LANE LINE - 6' DASH, 18' SKIP) | 9 | THERMOPLASTIC PAVEMENT MARKING - LINE 12" (WHITE DIAGONAL LINE) |
| 4 | THERMOPLASTIC PAVEMENT MARKING - LINE 4" (WHITE SOLID LINE) | 10 | THERMOPLASTIC PAVEMENT MARKING - LINE 24" (WHITE STOP LINE) |
| 5 | THERMOPLASTIC PAVEMENT MARKING - LINE 4" (YELLOW LINE - 6' DASH, 18' SKIP) | 11 | THERMOPLASTIC PAVEMENT MARKING - LETTERS AND SYMBOLS (TYP.) |
| 6 | THERMOPLASTIC PAVEMENT MARKING - LINE 6" (WHITE LANE LINE - 2' DASH, 6' SKIP) | | |

HOT-MIX ASPHALT SURFACE REMOVAL - BUTT JOINT

FILE NAME = m:\prow\3386\3386_23\design\proposedplan\3386_23-01.dgn

Ciorba Group, Inc.
CONSULTING ENGINEERS
5507 North Cumberland Avenue, Suite 402
Chicago, Illinois 60656
Tel. 773.775.4009 Fax 773.775.4014

USER NAME = wjancaster	DESIGNED - MWR	REVISED -
PLOT SCALE = 50.0000' / IN.	DRAWN - MWR	REVISED -
PLOT DATE = 7/17/2009	CHECKED - SNS	REVISED -
	DATE - 6/24/2009	REVISED -

**STATE OF ILLINOIS
DEPARTMENT OF TRANSPORTATION**

**STATE STREET
69TH STREET TO 60TH STREET
PROPOSED ROADWAY AND PAVEMENT MARKING PLAN**

SCALE: 1"=50' SHEET NO. OF SHEETS STA. TO STA.

F.A.U. RTE. 2907	SECTION 1Y (5,6 & 7) RS	COUNTY COOK	TOTAL SHEETS 17	SHEET NO. 6
FED. ROAD DIST. NO. 1 ILLINOIS FED. AID PROJECT			CONTRACT NO. 62404	

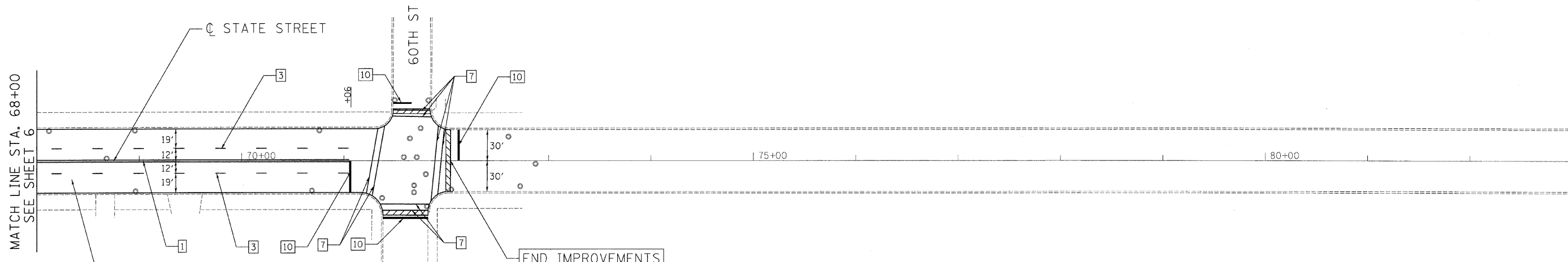
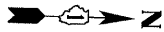

MATCH LINE STA. 68+00
SEE SHEET 6

HOT-MIX ASPHALT SURFACE REMOVAL, 2 1/4"
HOT-MIX ASPHALT SURFACE COURSE, MIX "D", N 70, 1 1/2"
POLYMERIZED LEVELING BINDER (MACHINE METHOD), IL-4.75, N50, 3/4"

HOT-MIX ASPHALT SURFACE
REMOVAL - BUTT JOINT

END IMPROVEMENTS
STA. 72+04
MATCH EXISTING
PAVEMENT MARKINGS

LEGEND:

- 1 THERMOPLASTIC PAVEMENT MARKING - LINE 4" (DOUBLE YELLOW SOLID LINE 8" C-C)
- 2 THERMOPLASTIC PAVEMENT MARKING - LINE 4" (YELLOW SOLID LINE)
- 3 THERMOPLASTIC PAVEMENT MARKING - LINE 4" (WHITE LANE LINE - 6' DASH, 18' SKIP)
- 4 THERMOPLASTIC PAVEMENT MARKING - LINE 4" (WHITE SOLID LINE)
- 5 THERMOPLASTIC PAVEMENT MARKING - LINE 4" (YELLOW LINE - 6' DASH, 18' SKIP)
- 6 THERMOPLASTIC PAVEMENT MARKING - LINE 6" (WHITE LANE LINE - 2' DASH, 6' SKIP)
- 7 THERMOPLASTIC PAVEMENT MARKING - LINE 6" (WHITE SOLID LINE)
- 8 THERMOPLASTIC PAVEMENT MARKING - LINE 12" (YELLOW DIAGONAL LINE)
- 9 THERMOPLASTIC PAVEMENT MARKING - LINE 12" (WHITE DIAGONAL LINE)
- 10 THERMOPLASTIC PAVEMENT MARKING - LINE 24" (WHITE STOP LINE)
- 11 THERMOPLASTIC PAVEMENT MARKING - LETTERS AND SYMBOLS (TYP.)

FILE NAME = n:\proj\3368\3368_2\design\proposedplan\3368_2b-prop03.dgn

Ciorba Group, Inc.
CONSULTING ENGINEERS
5507 North Cumberland Avenue, Suite 402
Chicago, Illinois 60656
Tel. 773.775.4009 Fax 773.775.4014

USER NAME = mready	DESIGNED - MWR	REVISED -
PLOT SCALE = 50.0000' / IN.	DRAWN - MWR	REVISED -
PLOT DATE = 6/24/2009	CHECKED - SNS	REVISED -
	DATE - 6/24/2009	REVISED -

**STATE OF ILLINOIS
DEPARTMENT OF TRANSPORTATION**

**STATE STREET
69TH STREET TO 60TH STREET
PROPOSED ROADWAY AND PAVEMENT MARKING PLAN**

SCALE: 1"=50' SHEET NO. OF SHEETS STA. TO STA.

F.A.U. RTE.	SECTION	COUNTY	TOTAL SHEETS	SHEET NO.
2907	1Y (5,6 & 7) RS	COOK	17	7
FED. ROAD DIST. NO. 1 ILLINOIS FED. AID PROJECT			CONTRACT NO. 62404	

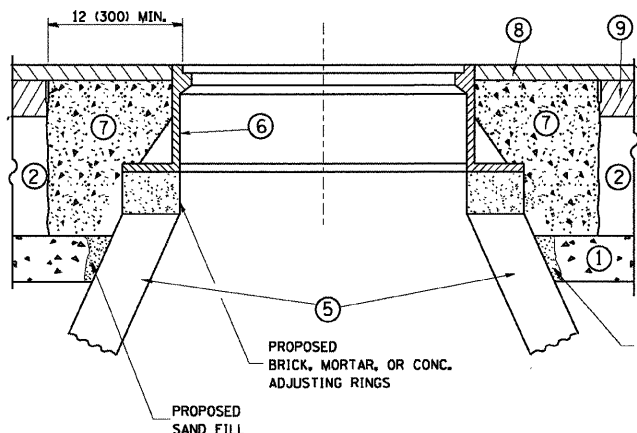
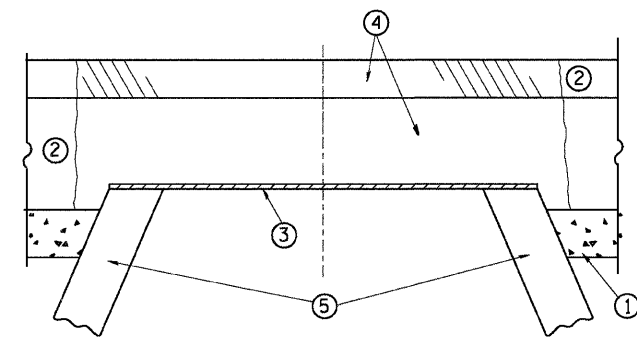

CONSTRUCTION PROCEDURES

STAGE 1 (BEFORE PAVEMENT MILLING)

- A) REMOVE A MINIMUM OF 12 (300) OF THE PAVEMENT FROM AROUND THE STRUCTURE.
- B) REMOVE THE EXISTING FRAME AND LID FROM THE STRUCTURE.
- C) COVER THE STRUCTURE OPENING WITH A 36 (900) DIAMETER METAL PLATE.
- D) BACKFILL WITH CRUSHED STONE AND A MINIMUM 1 1/2 (40) THICK HMA SURFACE MIX APPROVED BY THE ENGINEER.

STAGE 2 (AFTER PAVEMENT MILLING)

- A) REMOVE THE HMA SURFACE MIX AND CRUSHED STONE.
- B) INSTALL THE FRAME AND LID; ADJUST THE FRAME TO ITS FINAL SURFACE ELEVATION.
- C) THE SURROUNDING SPACE SHALL BE FILLED WITH CLASS SI CONCRETE, OR HMA SURFACE COURSE OR HMA BINDER COURSE TO THE ELEVATION OF THE SURFACE OF THE EXISTING BASE COURSE OR THE BINDER COURSE.

THE PROCEDURE EXPLAINED ABOVE SHALL CONFORM TO THE APPLICABLE PORTIONS OF SECTIONS 353, 406, 602, AND 603 OF THE STANDARD SPECIFICATIONS.

LEGEND

- ① SUB-BASE GRANULAR MATERIAL
- ② EXISTING PAVEMENT
- ③ 36 (900) DIAMETER METAL PLATE
- ④ PROPOSED CRUSHED STONE AND HMA SURFACE MIX
- ⑤ EXISTING STRUCTURE
- ⑥ FRAME AND LID (SEE NOTES)
- ⑦ CLASS SI CONCRETE, HMA SURFACE COURSE OR HMA BINDER COURSE
- ⑧ PROPOSED HMA SURFACE COURSE
- ⑨ PROPOSED HMA BINDER COURSE

NOTES:

EXISTING BROKEN FRAMES AND LIDS SHALL BE REMOVED AND DISPOSED OF BY THE CONTRACTOR AND SHALL BE REPLACED AS DIRECTED BY THE ENGINEER. REPLACEMENT FRAMES AND LIDS WILL BE PAID FOR IN ACCORDANCE WITH ARTICLE 109.04 OF THE STANDARD SPECIFICATIONS UNLESS A SEPARATE PAY ITEM HAS BEEN PROVIDED.

IF THE EXISTING LIDS ARE OPEN, THE FRAME WILL BE ADJUSTED TO THE ELEVATION OF THE MILLED PAVEMENT SURFACE PRIOR TO THE MILLING OPERATION. THE FRAME WILL NOT BE REMOVED AND COVERED BY THE METAL PLATE.

CITY OF CHICAGO CASTINGS ARE THE PROPERTY OF THE CITY AND THE CONTRACTOR SHALL NOTIFY THE CITY FOR REMOVAL AND DISPOSITION OF THE CASTINGS.

THE METAL PLATE USED TO COVER THE STRUCTURE SHALL REMAIN THE PROPERTY OF THE CONTRACTOR.

WHEN STRUCTURES ARE TO BE ADJUSTED OR RECONSTRUCTED, THE LOWERING AND RAISING OF THE FRAMES AND LIDS WILL NOT BE PAID FOR SEPARATELY BUT WILL BE INCLUDED IN THE COST OF THE CORRESPONDING PAY ITEM.

LOCATION OF STRUCTURES:

THE CONTRACTOR WILL BE REQUIRED TO KEEP A RECORD OF THE LOCATIONS OF THE BURIED STRUCTURES ACCORDING TO THE STATION AND DISTANCE LEFT OR RIGHT OF THE CENTERLINE OF PAVEMENT. UPON COMPLETION OF THE WORK, THE CONTRACTOR WILL DELIVER THE RECORD TO THE ENGINEER.

BASIS OF PAYMENT: THIS WORK WILL BE PAID FOR AT THE CONTRACT UNIT PRICE PER EACH FOR "FRAMES AND LIDS TO BE ADJUSTED, SPECIAL" NEW FRAMES AND LIDS, WHEN SPECIFIED, WILL BE PAID FOR SEPARATELY.

DETAILS FOR FRAMES AND LIDS ADJUSTMENT WITH MILLING

ALL DIMENSIONS ARE IN INCHES (MILLIMETERS) UNLESS OTHERWISE SHOWN

FILE NAME = W:\diststd\22x34\bd08.dgn	USER NAME = geglentobt	DESIGNED - R. SHAH	REVISED - R. SHAH 03-10-95	STATE OF ILLINOIS DEPARTMENT OF TRANSPORTATION	DETAILS FOR FRAMES AND LIDS ADJUSTMENT WITH MILLING			F.A.U. RTE.	SECTION	COUNTY	TOTAL SHEETS	SHEET NO.
	PLOT SCALE = 50.0000' / 1"	CHECKED -	REVISED - A. ABBAS 03-21-97		2907	1Y (5,6 & 7) RS	COOK	17	8			
PLOT DATE = 1/4/2008	DATE - 10-25-94	REVISED - R. WIEDEMAN 05-14-04	REVISED - R. BORO 01-01-07	SCALE: NONE	SHEET NO. 1 OF 1 SHEETS	STA. TO STA.	BD600-03 (BD-8)		CONTRACT NO. 62404			
							FED. ROAD DIST. NO. 1 ILLINOIS FED. AID PROJECT					

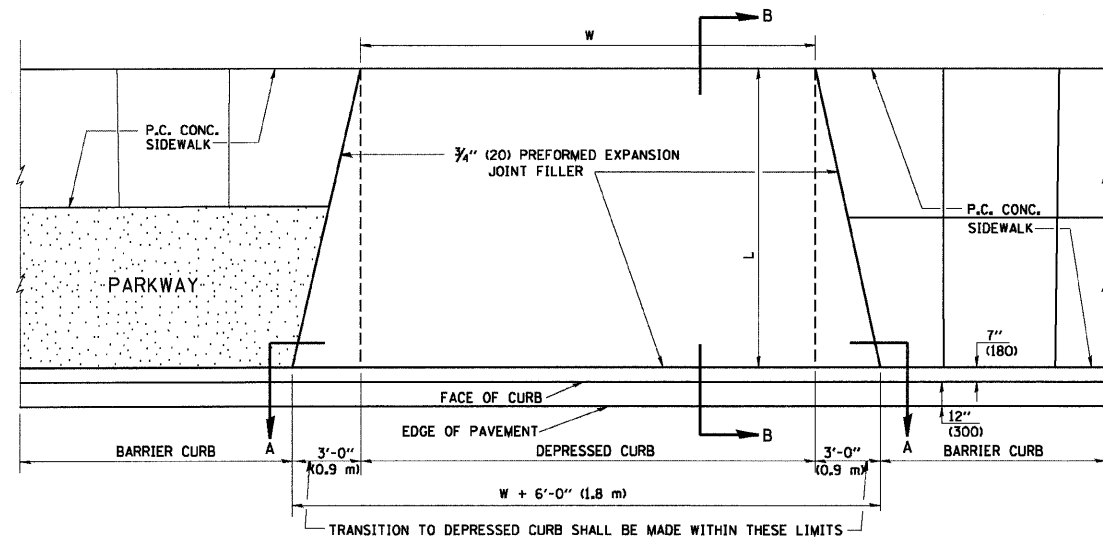

PLAN VIEW

NOTES:

1. EXPANSION JOINTS SHALL BE CONSTRUCTED AS SHOWN ON THE DETAILS FOR P.C.C. SIDEWALK.
2. THE CURB BETWEEN ADJACENT DRIVEWAYS SHALL BE FULL HEIGHT FOR A DISTANCE OF AT LEAST FOUR FEET (1.2 METERS).
3. P.C. CONCRETE DRIVEWAYS SHALL BE CONSTRUCTED AT LOCATIONS SHOWN ON THE PLANS OR AS DIRECTED BY THE ENGINEER.
4. 3/4" (20) PREFORMED EXPANSION JOINTS WILL NOT BE PAID FOR SEPARATELY BUT SHALL BE CONSIDERED INCIDENTAL TO P.C.C. DRIVEWAY PAVEMENT 8" (200).
5. COMBINATION CONC. CURB AND GUTTER SHALL BE MEASURED STRAIGHT ACROSS THE DRIVEWAY. NO ADDITIONAL COMPENSATION WILL BE ALLOWED FOR THE TRANSITION CURB AND GUTTER.

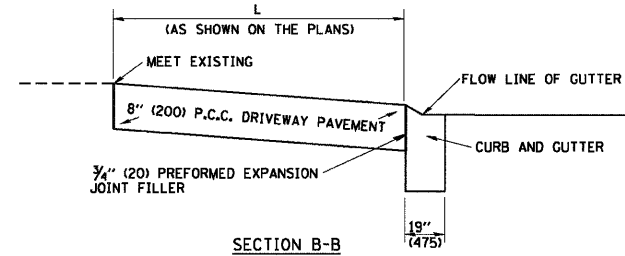

SECTION B-B

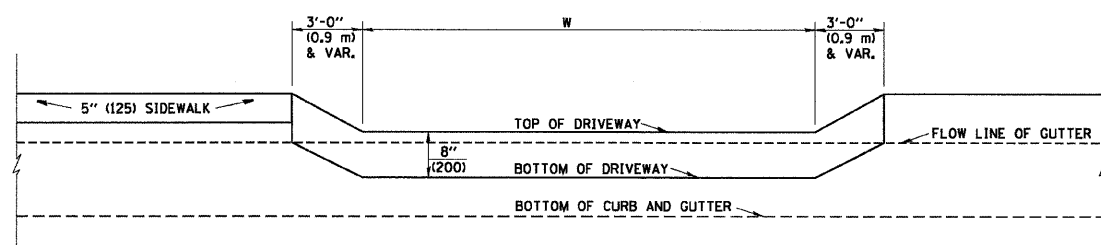

SECTION A-A

P.C.C. DRIVEWAY PAVEMENT DETAIL

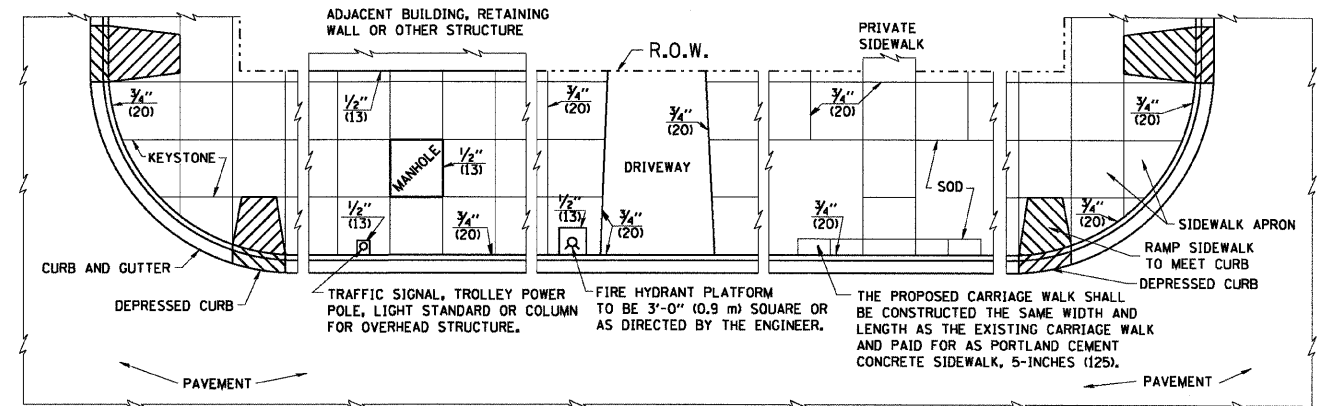

NOTES:

1. ONE-HALF INCH THICK EXPANSION JOINTS SHALL BE PLACED BETWEEN THE SIDEWALK AND ALL STRUCTURES SUCH AS LIGHT STANDARDS, TRAFFIC LIGHT STANDARDS, MANHOLES, WHICH EXTEND THROUGH THE SIDEWALK.
2. 3/4" (20) THICK EXPANSION JOINTS SHALL BE PLACED AT INTERVALS OF NOT MORE THAN 100 FEET (30 METERS) IN THE SIDEWALK. WHERE THE SIDEWALK IS CONSTRUCTED ADJACENT TO PAVEMENT OR CURB HAVING EXPANSION JOINTS, THE EXPANSION JOINTS IN THE SIDEWALK SHALL BE PLACED OPPOSITE THE EXISTING EXPANSION JOINTS AS NEARLY AS PRACTICABLE. EXPANSION JOINTS SHALL ALSO BE PLACED WHERE THE SIDEWALK ABUTS EXISTING SIDEWALKS, BETWEEN DRIVEWAY PAVEMENT AND SIDEWALK, AND BETWEEN SIDEWALK AND CURBS WHERE THE SIDEWALK ABUTS A CURB.

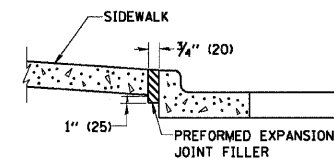

SLOPE FOR SIDEWALK
1" (25) IN 3'-0" (0.9 m) IN CHICAGO

PORTLAND CEMENT CONCRETE SIDEWALK DETAILS

NOTES: NO EXTRA COMPENSATION SHALL BE ALLOWED FOR THE GUTTER FLARE

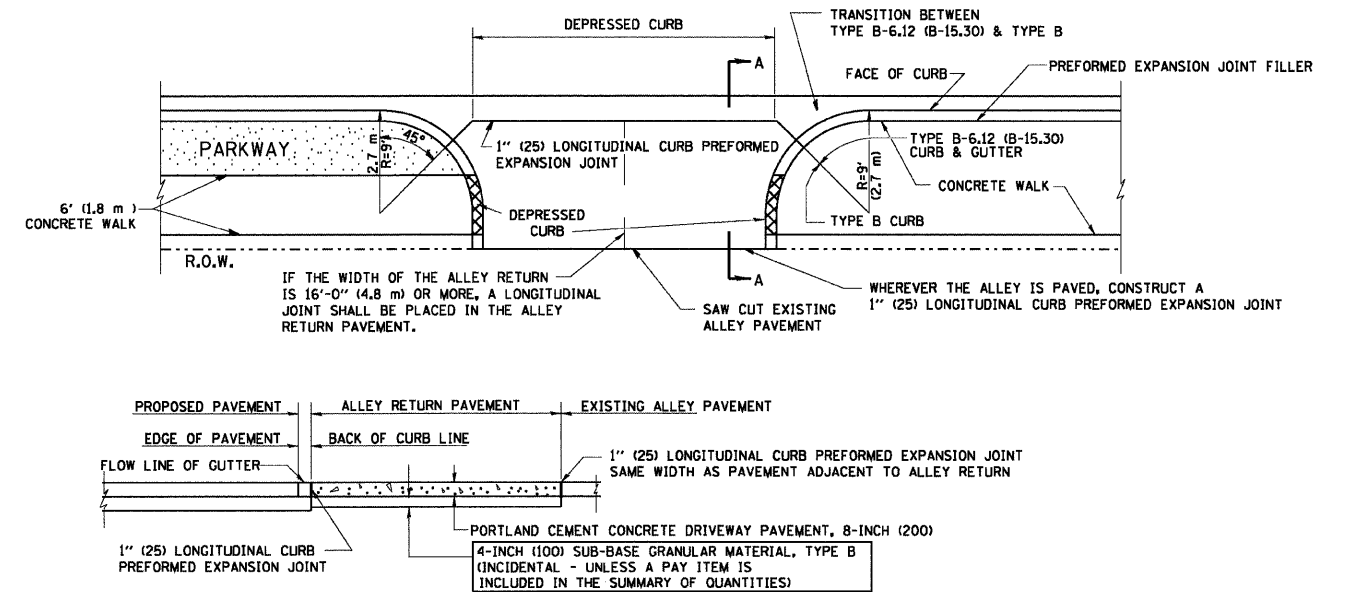

SECTION A-A

ALLEY RETURN DETAIL

ALL DIMENSIONS ARE IN INCHES (MILLIMETERS) UNLESS OTHERWISE SHOWN

FILE NAME = W:\diststd\22x34\bd17.dgn	USER NAME = gaglianob	DESIGNED - M. DE YONG	REVISED -
	PLOT SCALE = 50.0000' / IN.	DRAWN -	REVISED -
	PLOT DATE = 1/4/2008	CHECKED -	REVISED -
		DATE - 06-13-90	REVISED -

STATE OF ILLINOIS
DEPARTMENT OF TRANSPORTATION

CITY OF CHICAGO
DETAILS FOR P.C. CONCRETE DRIVEWAY, ALLEY RETURN AND SIDEWALK

SCALE: NONE SHEET NO. 1 OF 1 SHEETS STA. TO STA.

F.A.U. RTE.	SECTION	COUNTY	TOTAL SHEETS	SHEET NO.
2907	1Y (5,6 & 7) RS	COOK	17	9
BD400-03 (BD-17)		CONTRACT NO.	62404	
FED. ROAD DIST. NO. 1 ILLINOIS FED. AID PROJECT				

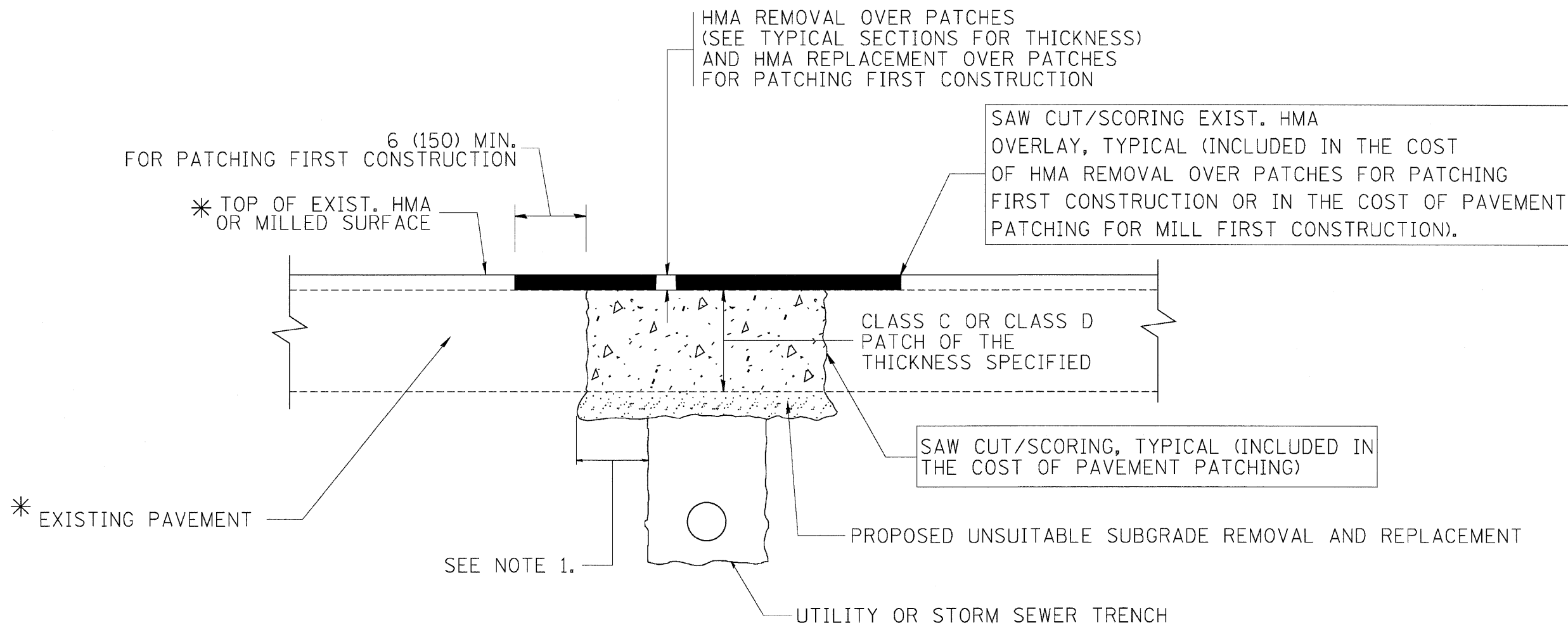

* SEE TYPICAL SECTIONS FOR THICKNESS AND MATERIALS

NOTES:

1. THE WIDTH OF THE FULL DEPTH PATCH OVER A TRENCH SHALL BE 12 (300) WIDER ON EACH SIDE OF THE TRENCH.
2. FOR METHOD OF MEASUREMENT AND BASIS OF PAYMENT, SEE RECURRING SPECIAL PROVISION "PATCHING WITH HOT-MIX ASPHALT OVERLAY REMOVAL".

SEQUENCE OF CONSTRUCTION (PATCHING FIRST)

1. REMOVE THE EXISTING HMA MATERIAL OVER THE AREA TO BE PATCHED.
2. REMOVE AND REPLACE WITH CLASS C OR D PATCH.
3. REPLACE HMA MATERIAL OVER THE AREA TO BE PATCHED.

SEQUENCE OF CONSTRUCTION (MILLING FIRST)

1. MILL HMA FIRST IF THERE IS AT LEAST 4 1/2 INCHES OR MORE OF HMA MATERIAL ON TOP OF THE EXISTING PAVEMENT OR IF THE PAVEMENT IS FULL DEPTH HMA. A MINIMUM OF 2 INCHES OF HMA MATERIAL SHALL BE IN PLACE AFTER MILLING.
2. REMOVE AND REPLACE WITH FULL DEPTH CLASS D PATCHES TO TOP OF MILLED SURFACE.

ALL DIMENSIONS ARE IN INCHES (MILLIMETERS) UNLESS OTHERWISE SHOWN.

FILE NAME = es:\proj\jeota\dist\td22x34\bd22.dgn	USER NAME = bauerj	DESIGNED - R. SHAH	REVISED - A. ABBAS 04-27-98	STATE OF ILLINOIS DEPARTMENT OF TRANSPORTATION	PAVEMENT PATCHING FOR HMA SURFACED PAVEMENT		F.A.U. RTE. 2907	SECTION 1Y (5,6 & 7) RS	COUNTY COOK	TOTAL SHEETS 17	SHEET NO. 10
	PLOT SCALE = 50.000' / IN.	DRAWN -	REVISED - R. BORO 01-01-07		SCALE: NONE	SHEET NO. 1 OF 1 SHEETS	STA.	TO STA.	BD400-04 (BD-22)		CONTRACT NO. 62404
	PLOT DATE = 10/27/2008	CHECKED -	REVISED - R. BORO 09-04-07		FED. ROAD DIST. NO. 1 ILLINOIS FED. AID PROJECT						
		DATE - 10-25-94	REVISED - K. ENG 10-27-08								

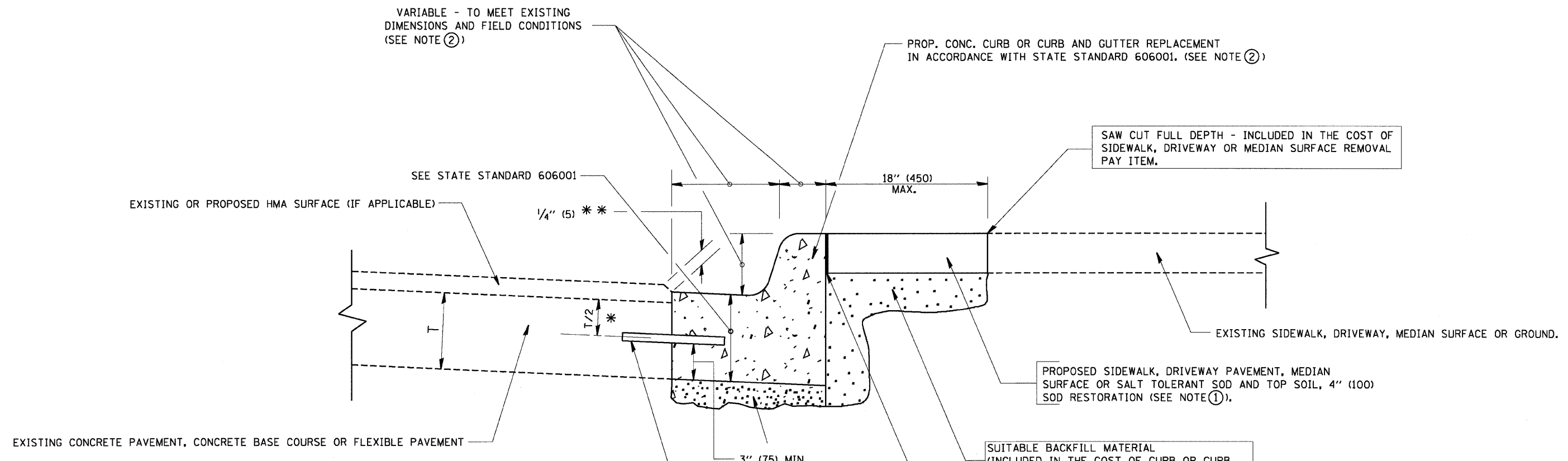

- * 3" (75) MINIMUM FROM TOP AND BOTTOM OF THE CONCRETE PAVEMENT OR BASE COURSE.
 - * * IF THE FINAL SURFACE OF THE PAVEMENT IS CONCRETE, THE GUTTER IS TO BE FLUSH WITH THE PAVEMENT.
- NOTE: ① SIDEWALK, DRIVEWAY PAVEMENT OR MEDIAN SURFACE SHALL BE SIMILAR TO THE MATERIAL BEING REMOVED AND WILL BE PAID FOR SEPARATELY.
- SALT TOLERANT SOD AND TOP SOIL, 4" (100) RESTORATION WILL NOT BE PAID FOR SEPARATELY, BUT SHALL BE INCLUDED IN THE COST OF CURB OR CURB AND GUTTER REMOVAL AND REPLACEMENT.
- ② CURB OR CURB AND GUTTER REPLACEMENT SHALL MATCH THE SHAPE OF THE EXISTING CURB OR CURB AND GUTTER UNLESS OTHERWISE SPECIFIED.
 - ③ FOR CURB OR CURB AND GUTTER REMOVAL AND REPLACEMENT ADJACENT TO FLEXIBLE PAVEMENT DELETE EPOXY COATED TIE BARS.
 - ④ LONGITUDINAL BARS, IF ENCOUNTERED IN THE EXISTING CURB OR CURB AND GUTTER, ARE NOT TO BE REPLACED. CUTTING AND REMOVING LONGITUDINAL BARS SHALL BE INCLUDED IN THE COST OF CURB OR CURB AND GUTTER REMOVAL AND REPLACEMENT.
 - ⑤ THE COST OF HMA SURFACE REMOVAL IN THE EXISTING GUTTER FLAG SHALL BE INCLUDED IN THE COST OF THE CURB AND GUTTER REMOVAL AND REPLACEMENT.
 - ⑥ THE REMOVAL AND REPLACEMENT OF THE EXISTING CURB OR CURB AND GUTTER SHALL BE DONE IN ACCORDANCE WITH THE APPLICABLE PORTIONS OF SECTION 440 AND 606 OF THE STANDARD SPECIFICATIONS.
 - ⑦ THE LOCATIONS OF REMOVAL AND REPLACEMENT OF EXISTING CURB OR CURB AND GUTTER SHALL BE DETERMINED BY THE RESIDENT ENGINEER AT THE TIME OF CONSTRUCTION.

- PROPOSED 3/4" (20) PREFORMED EXPANSION JOINT AT CONCRETE SIDEWALKS, DRIVEWAYS, AND MEDIANS. (INCLUDED IN THE COST OF CURB OR CURB AND GUTTER REMOVAL AND REPLACEMENT.)
- UNSUITABLE SUB-BASE MATERIAL TO BE REMOVED, IF DIRECTED BY THE ENGINEER, SHALL BE REPLACED WITH EITHER SUB-BASE GRANULAR MATERIAL, TYPE B OR ADDITIONAL THICKNESS OF CONCRETE.
- REMOVAL AND REPLACEMENT 4" (100) OR LESS IS INCLUDED IN THE COST OF CURB OR CURB AND GUTTER REMOVAL AND REPLACEMENT.
- REMOVAL AND REPLACEMENT IN EXCESS OF 4" (100) WILL BE PAID FOR IN ACCORDANCE WITH ARTICLE 109.04 OF THE STANDARD SPECIFICATIONS.
- PROPOSED #6 (20) EPOXY COATED TIE BARS 24" (600) LONG AT 24" (600) CENTERS WILL NOT BE PAID FOR SEPARATELY. DELETE EPOXY COATED TIE BARS IF EXISTING TIE BARS ARE USUABLE AS DETERMINED BY THE ENGINEER. (SEE NOTE ③).

BASIS OF PAYMENT:
 THIS WORK WILL BE PAID FOR AT THE CONTRACT UNIT PRICE PER FOOT (METER) FOR "CURB REMOVAL AND REPLACEMENT" OR "COMBINATION CONCRETE CURB AND GUTTER REMOVAL AND REPLACEMENT".

CURB OR CURB AND GUTTER REMOVAL AND REPLACEMENT

ALL DIMENSIONS ARE IN INCHES (MILLIMETERS) UNLESS OTHERWISE SHOWN.

FILE NAME = W:\diststd\22x34\bd24.dgn	USER NAME = geglienobt	DESIGNED - A. HOUSEH	REVISED - R. SHAH 10-03-96	STATE OF ILLINOIS DEPARTMENT OF TRANSPORTATION	CURB OR CURB AND GUTTER REMOVAL AND REPLACEMENT	F.A.U. RTE. 2907	SECTION 1Y (5,6 & 7) RS	COUNTY COOK	TOTAL SHEETS 17	SHEET NO. 11
	PLOT SCALE = 50,000' / IN.	DRAWN -	REVISED - A. ABBAS 03-21-97			BD600-06 (BD-24)		CONTRACT NO. 62404		
	PLOT DATE = 1/4/2008	DATE - 03-11-94	REVISED - M. GOMEZ 01-22-01		SCALE: NONE	SHEET NO. 1 OF 1 SHEETS		STA. TO STA.		
						FED. ROAD DIST. NO. 1 ILLINOIS FED. AID PROJECT				

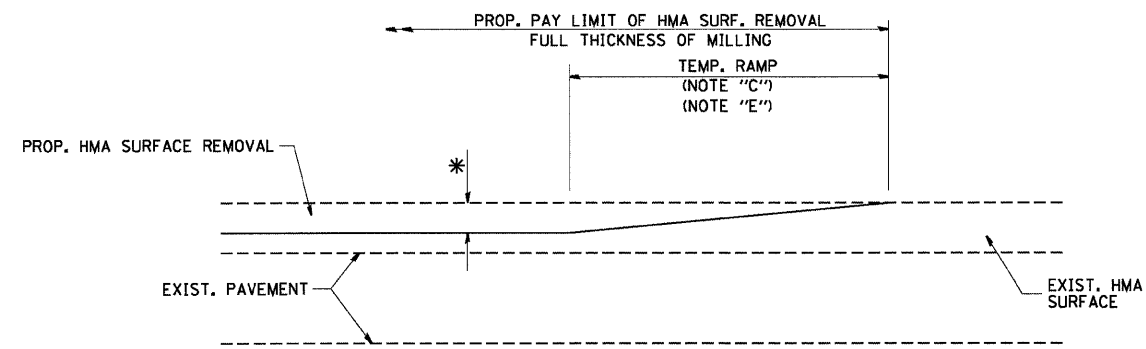

MILLED TEMPORARY RAMP
(FOR BUTT JOINT AND HMA TAPER SEE DETAIL BELOW)

OPTION 1

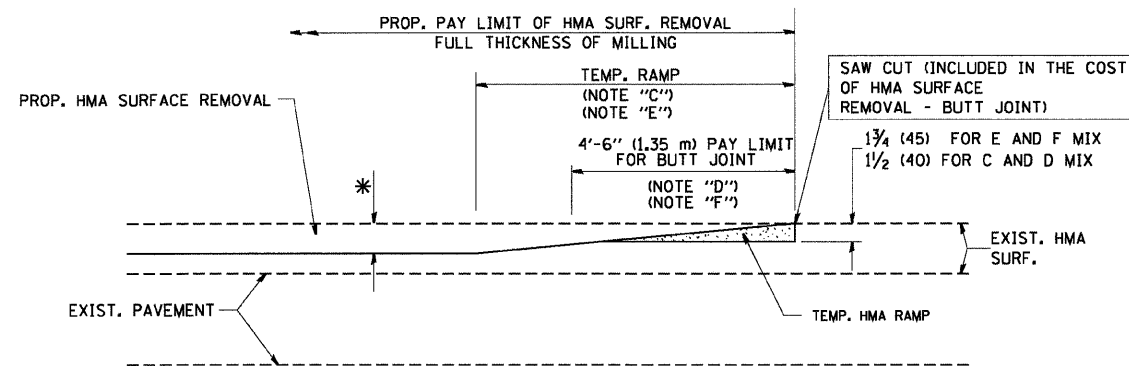

HMA CONSTRUCTED TEMPORARY RAMP
(FOR BUTT JOINT AND HMA TAPER SEE DETAIL BELOW)

OPTION 2

TYPICAL TEMPORARY RAMP

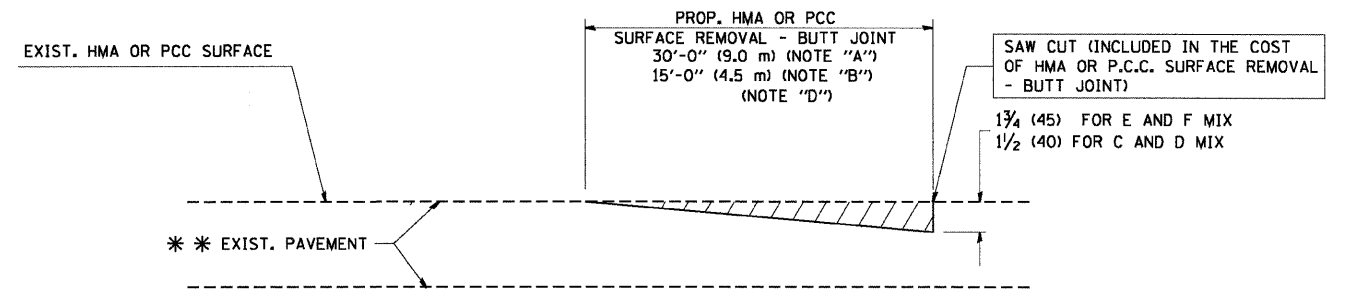

BUTT JOINT DETAIL

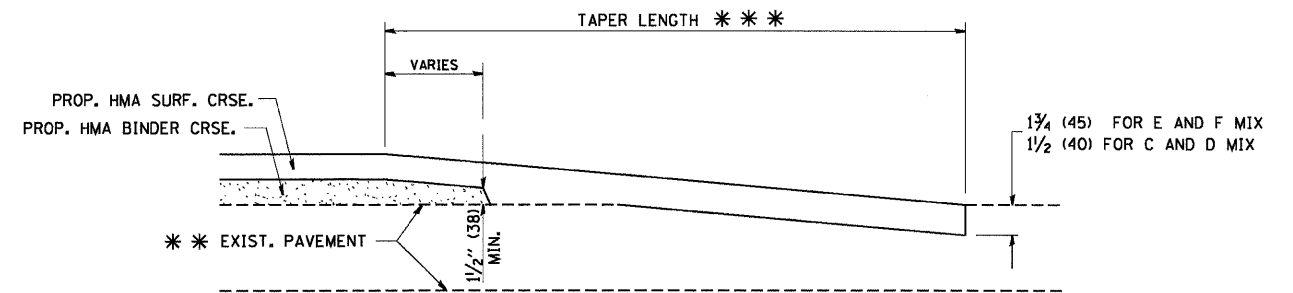

HMA TAPER DETAIL

TYPICAL BUTT JOINT AND HMA TAPER FOR RESURFACING ONLY

*** PC CONCRETE, HMA OR HMA RESURFACED PAVEMENT.

NOTES

- A: MAINLINE ROADWAYS AND MAJOR SIDE ROADS.
 - B: MINOR SIDE ROADS.
 - C: THE TEMP. RAMP SHALL BE CONSTRUCTED IMMEDIATELY UPON REMOVAL OF THE EXISTING HMA SURFACE.
 - D: THE BUTT JOINT SHALL BE CONSTRUCTED IMMEDIATELY PRIOR TO PLACING THE PROPOSED HMA COURSES.
 - E: TAPER THE TEMP. RAMP AT A RATE OF 3'-0" (900 mm) PER 1 INCH (25 mm) OF MILLING THICKNESS.
 - F: INSTALLATION AND REMOVAL OF THE 4'-6" (1.35 m) TEMP. RAMP IS INCLUDED IN COST OF HMA SURFACE REMOVAL - BUTT JOINT
 - G: SEE ARTICLE 406.08 AND 406.14 OF THE STANDARD SPECIFICATIONS FOR "HMA AND/OR PCC SURFACE REMOVAL, BUTT JOINT".
- * SEE TYPICAL SECTIONS FOR MILLING THICKNESS.

*** 20'-0" (6.1 m) PER 1 (25) RESURFACING (NOTE "A")
10'-0" (3.0 m) PER 1 (25) RESURFACING (NOTE "B")

BASIS OF PAYMENT:

THE BUTT JOINT WILL BE PAID FOR AT THE CONTRACT UNIT PRICE PER SQUARE YARD (SQUARE METER) FOR "HOT-MIX ASPHALT SURFACE REMOVAL - BUTT JOINT" OR FOR "PORTLAND CEMENT CONCRETE SURFACE REMOVAL - BUTT JOINT".

ALL DIMENSIONS ARE IN INCHES (MILLIMETERS) UNLESS OTHERWISE SHOWN.

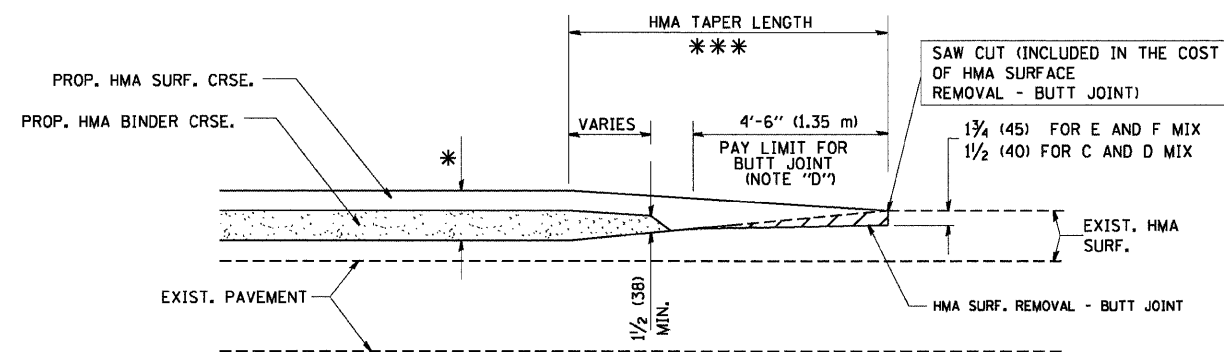

BUTT JOINT AND HMA TAPER

TYPICAL BUTT JOINT AND HMA TAPER FOR MILLING AND RESURFACING

FILE NAME = W:\diststd\22x34\bd32.dgn	USER NAME = geglennobt	DESIGNED - M. DE YONG	REVISED - R. SHAH 10-25-94
		DRAWN -	REVISED - A. ABBAS 03-21-97
	PLOT SCALE = 50.0000' / IN.	CHECKED -	REVISED - M. GOMEZ 04-06-01
	PLOT DATE = 1/4/2008	DATE - 06-13-90	REVISED - R. BORO 01-01-07

**STATE OF ILLINOIS
DEPARTMENT OF TRANSPORTATION**

BUTT JOINT AND HMA TAPER DETAILS			
SCALE: NONE	SHEET NO. 1 OF 1 SHEETS	STA.	TO STA.

F.A.U. RTE.	SECTION	COUNTY	TOTAL SHEETS	SHEET NO.
2907	1Y (5,6 & 7) RS	COOK	17	12
BD400-05 BD32			CONTRACT NO. 62404	
FED. ROAD DIST. NO. 1 ILLINOIS FED. AID PROJECT				

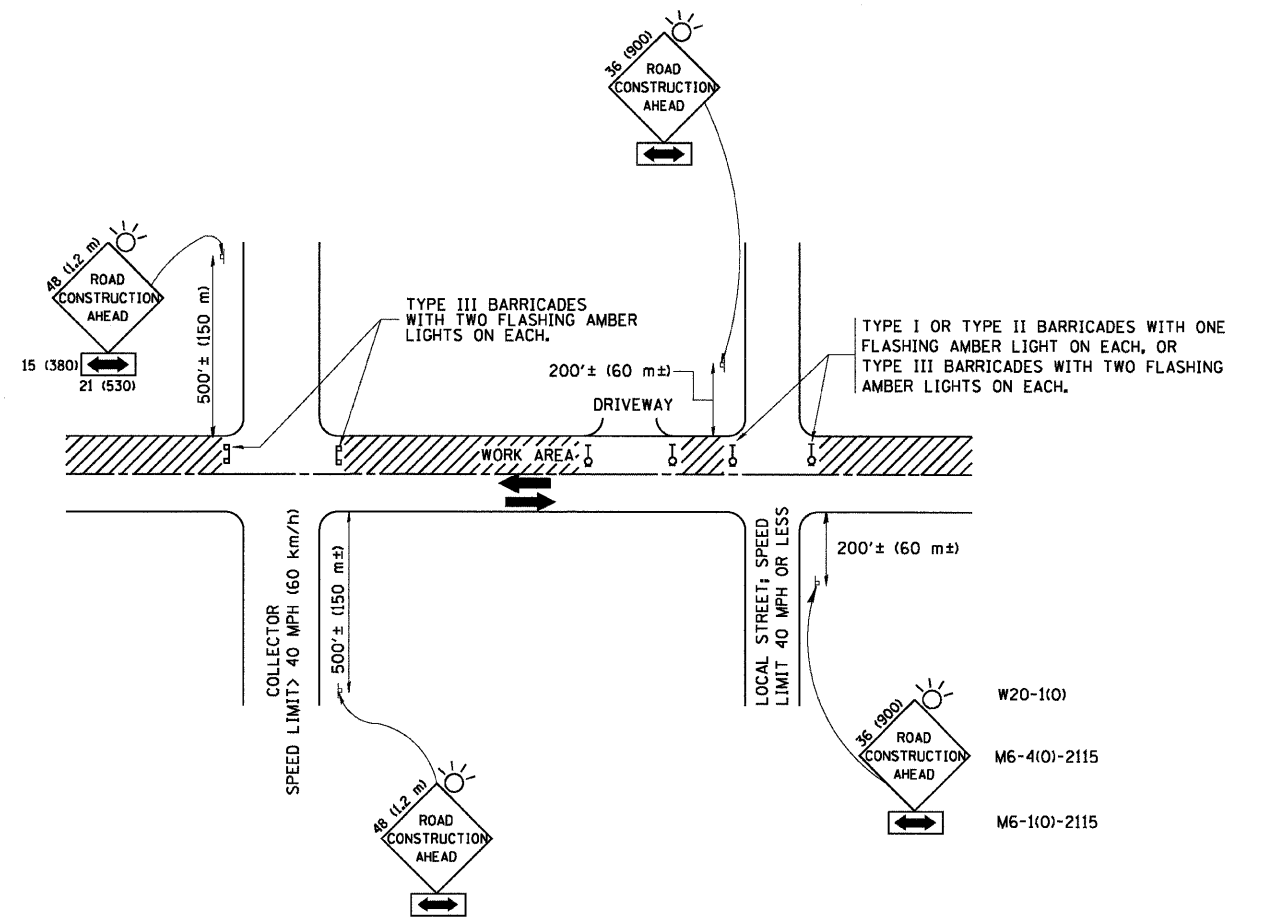

TRAFFIC CONTROL AND PROTECTION FOR SIDE ROADS, INTERSECTIONS, AND DRIVEWAYS

NOTES:

- A. FOR NO LANE RESTRICTION ON THE SIDE ROAD OR DRIVEWAYS
 - 1. SIDE ROAD WITH A SPEED LIMIT OF 40 MPH (60 km/h) OR LESS AS SHOWN ON THE DRAWING AND AS DIRECTED BY THE ENGINEER:
 - a) ONE ROAD CONSTRUCTION AHEAD SIGN 36 x 36 (900x900) WITH A FLASHER AND FLAG MOUNTED ON IT APPROXIMATELY 200' (60 m) IN ADVANCE OF THE MAIN ROUTE.
 - b) THE CLOSED PORTION OF THE MAIN ROUTE SHALL BE PROTECTED BY BLOCKING WITH TYPE I, TYPE II OR TYPE III BARRICADES, 1/3 OF THE CROSS SECTION OF THE CLOSED PORTION.
 - 2. SIDE ROAD WITH A SPEED LIMIT GREATER THAN 40 MPH (60 km/h) AS SHOWN ON THE DRAWING AND AS DIRECTED BY THE ENGINEER:
 - a) ONE ROAD CONSTRUCTION AHEAD SIGN 48 x 48 (1.2 m x 1.2 m) WITH A FLASHER MOUNTED ON IT APPROXIMATELY 500' (150 m) IN ADVANCE OF THE MAIN ROUTE.
 - b) THE CLOSED PORTION OF THE MAIN ROUTE SHALL BE PROTECTED BY BLOCKING WITH TYPE III BARRICADES, 1/2 OF THE CROSS SECTION OF THE CLOSED PORTION.
 - 3. WHEN THE SIDE ROAD LIES BETWEEN THE BEGINNING OF THE MAINLINE SIGNING AND THE WORK ZONE, A SINGLE HEADED ARROW (M6-1) SHALL BE USED IN LIEU OF THE DOUBLE HEADED ARROW (M6-4).
- B. FOR A LANE CLOSURE ON A SIDE ROAD OR DRIVEWAYS:
 - USE APPLICABLE PORTIONS OF THE TYPICAL APPLICATION OF TRAFFIC CONTROL DEVICES (STD. 701501, STD. 701606 OR THE APPROPRIATE STANDARD). THE SPACING OF SIGNS AND BARRICADES SHALL BE ADJUSTED FOR FIELD CONDITIONS AS DIRECTED BY THE ENGINEER. THE DIRECTIONAL ARROW SHALL BE COVERED OR REMOVED WHEN NO LONGER CONSISTENT WITH THE SIDE ROAD LANE CLOSURE.
- C. ADVANCE WARNING SIGNS ARE TO BE OMITTED ON DRIVEWAY UNLESS OTHERWISE NOTED.
- D. THE TRAFFIC CONTROL AND PROTECTION FOR SIDE ROADS, INTERSECTIONS, AND DRIVEWAYS SHALL BE INCIDENTAL TO THE COST OF SPECIFIED TRAFFIC CONTROL STANDARDS OR ITEMS.

All dimensions are in millimeters (Inches) unless otherwise shown.

FILE NAME = W:\diststd\22x34\to10.dgn	USER NAME = goglianobt	DESIGNED - LHA	REVISED - J. OBERLE 10-18-95
		DRAWN -	REVISED - A. HOUSEH 03-06-96
	PLOT SCALE = 50,000 "/ IN.	CHECKED -	REVISED - A. HOUSEH 10-15-96
	PLOT DATE = 1/4/2008	DATE - 06-89	REVISED - T. RAMMACHER 01-06-00

STATE OF ILLINOIS
DEPARTMENT OF TRANSPORTATION

TRAFFIC CONTROL AND PROTECTION FOR
SIDE ROADS, INTERSECTIONS, AND DRIVEWAYS
SCALE: NONE SHEET NO. 1 OF 1 SHEETS STA. TO STA.



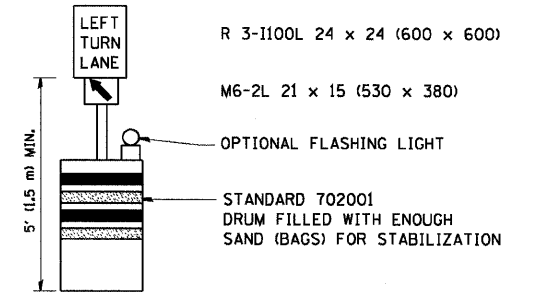
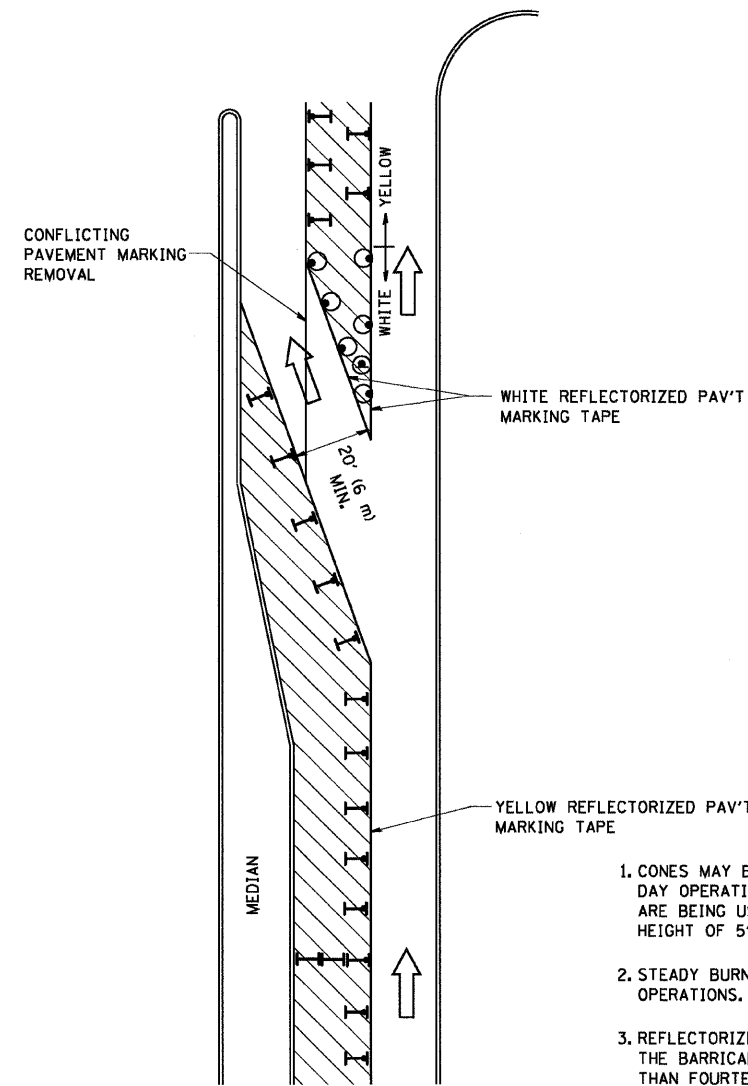



F.A.U. RTE.	SECTION	COUNTY	TOTAL SHEETS	SHEET NO.
2907	1Y (5,6 & 7) RS	COOK	17	13
TC-10			CONTRACT NO. 62404	
FED. ROAD DIST. NO. 1 ILLINOIS FED. AID PROJECT				



GENERAL NOTES

1. CONES MAY BE SUBSTITUTED FOR BARRICADES OR DRUMS AT HALF THE SPACING DURING DAY OPERATIONS. CONES SHALL BE A MINIMUM OF 28 (710) IN HEIGHT. WHEN CONES ARE BEING USED, THE "LEFT TURN LANE" SIGN MAY BE SKID MOUNTED AT A MINIMUM HEIGHT OF 5' (1.5 m).
2. STEADY BURNING LIGHTS WILL NOT BE REQUIRED ON BARRICADES OR DRUMS FOR DAY OPERATIONS. ALL LIGHTS SHALL BE MONODIRECTIONAL.
3. REFLECTORIZED TEMPORARY PAVEMENT MARKING TAPE SHALL BE PLACED THROUGHOUT THE BARRICADED AREA OF EACH TURN BAY WHERE THE CLOSURE TIME IS GREATER THAN FOURTEEN DAYS.
4. THIS APPLICATION ALSO APPLIES WHEN WORK IS BEING PERFORMED IN THE RIGHT LANE(S) AND THE RIGHT TURN BAY IS TO REMAIN OPEN. UNDER THIS CONDITION, "RIGHT TURN LANE" R3-100 24 x 24 (600 x 600) AND M6-2R 21 x 15 (530 x 380) SHALL BE USED.
5. THESE CONTROLS SHALL SUPPLEMENT MAINLINE TRAFFIC CONTROL FOR LANE CLOSURES.
6. LONGITUDINAL DIMENSIONS MAY BE ADJUSTED TO FIT FIELD CONDITIONS.
7. FORM BT 725 IS REQUIRED.
8. TRAFFIC CONTROL AND PROTECTION AT TURN BAYS (TO REMAIN OPEN TO TRAFFIC) SHALL BE INCLUDED IN THE COST SPECIFIED TRAFFIC CONTROL STANDARDS OR ITEMS.

LEGEND

-  WORK AREA
-  LANE OPEN TO TRAFFIC
-  TYPE I OR II BARRICADE WITH STEADY BURN LIGHT
-  DRUM WITH STEADY BURN LIGHT
-  DRUM WITH SIGN (WITH OPTIONAL FLASHING LIGHT) SEE DETAIL
-  TYPE I OR II CHECK BARRICADE WITH FLASHING LIGHT

All dimensions are in inches (millimeters) unless otherwise shown.

FILE NAME = W:\dststd\22x34\to14.dgn	USER NAME = geglienobt	DESIGNED -	REVISED -T. RAMMACHER 09-08-94
		DRAWN -	REVISED - A. HOUSEH 11-07-95
	PLOT SCALE = 50,0000' / IN.	CHECKED -	REVISED - A. HOUSEH 10-12-96
	PLOT DATE = 1/4/2008	DATE -	REVISED -T. RAMMACHER 01-06-00

**STATE OF ILLINOIS
DEPARTMENT OF TRANSPORTATION**

**TRAFFIC CONTROL AND PROTECTION AT TURN BAYS
(TO REMAIN OPEN TO TRAFFIC)**

SCALE: NONE SHEET NO. 1 OF 1 SHEETS STA. TO STA.

F.A.I.D. RTE.	SECTION	COUNTY	TOTAL SHEETS	SHEET NO.
2907	1Y (5,6 & 7) RS	COOK	17	14
TC-14			CONTRACT NO. 62404	
FED. ROAD DIST. NO. 1 ILLINOIS FED. AID PROJECT				

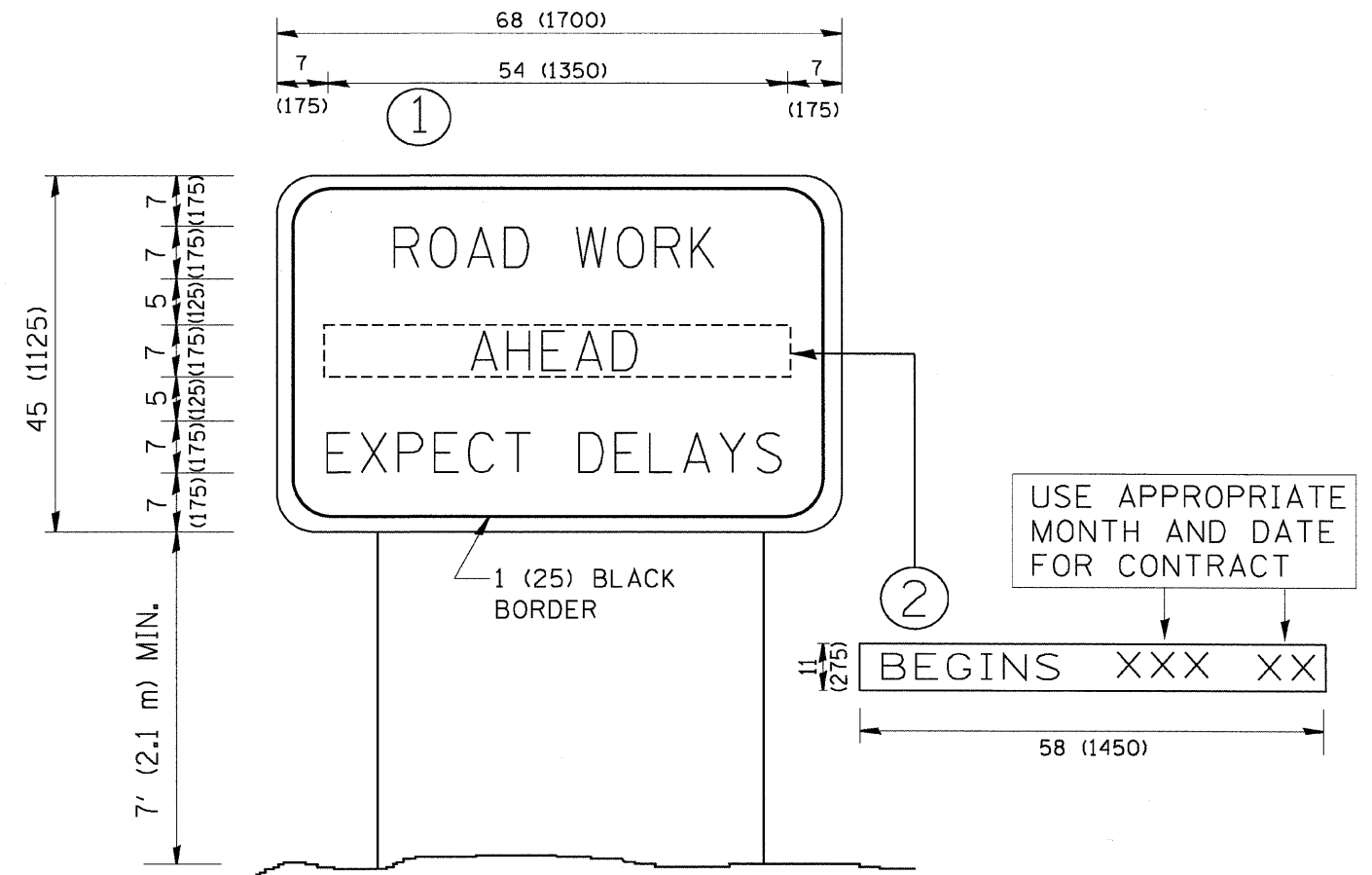

NOTES:

1. USE BLACK LETTERING ON ORANGE BACKGROUND.
2. ERECT SIGNS IN ADVANCE OF THE LOCATION FOR THE "ROAD CONSTRUCTION AHEAD" SIGN AT LOCATIONS AS DIRECTED BY THE ENGINEER.
3. ERECT SIGN ① WITH INSTALLED PANEL ② ONE WEEK PRIOR TO THE START OF CONSTRUCTION.
4. REMOVE PANEL ② SOON AFTER THE START OF CONSTRUCTION.
5. SEE SPECIAL PROVISION FOR "TEMPORARY INFORMATION SIGNING" FOR ADDITIONAL INFORMATION.
6. ONE SIGN ASSEMBLY EQUALS 25.70 SQ. FT. (2.3 SQ. M.)
7. SHALL BE PAID FOR AS TEMPORARY INFORMATION SIGNING.

ALL DIMENSIONS ARE IN INCHES (MILLIMETERS) UNLESS OTHERWISE SHOWN.

FILE NAME = W:\diststd\22x34\to22.dgn	USER NAME = gogliobbt	DESIGNED -	REVISED - R. MIRS 09-15-97
		DRAWN -	REVISED - R. MIRS 12-11-97
	PLOT SCALE = 50.000 "/ IN.	CHECKED -	REVISED - T. RAMMACHER 02-02-99
	PLOT DATE = 1/4/2008	DATE -	REVISED - C. JUCIUS 01-31-07

**STATE OF ILLINOIS
DEPARTMENT OF TRANSPORTATION**

ARTERIAL ROAD INFORMATION SIGN			
SCALE: NONE	SHEET NO. 1 OF 1 SHEETS	STA.	TO STA.

F.A.U. RTE.	SECTION	COUNTY	TOTAL SHEETS	SHEET NO.
2907	1Y (5,6 & 7) RS	COOK	17	15
TC-22			CONTRACT NO. 62404	
FED. ROAD DIST. NO. 1 ILLINOIS FED. AID PROJECT				

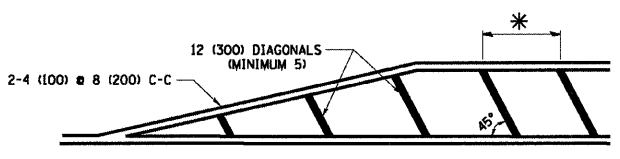
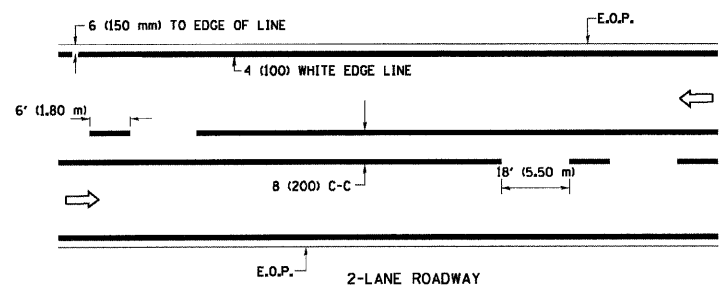

FOR MEDIAN LENGTHS WHERE DIAGONAL SPACING CANNOT BE ATTAINED, USE 5 (FIVE) EQUALLY SPACED DIAGONAL LINES.
DIAGONAL LINE SPACING: 20' (6.1 m) C-C

PAINTED MEDIANS

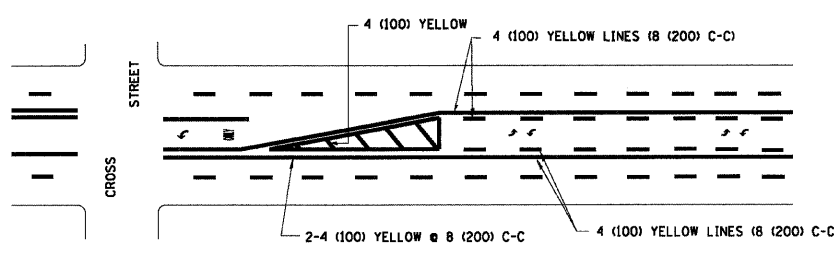

A MINIMUM OF TWO PAIRS OF TURN ARROWS SHALL BE USED, WHITE IN COLOR. ADDITIONAL PAIRS SHALL BE PLACED AT 200' (60 m) TO 300' (90 m) INTERVALS.

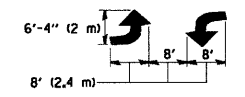

TYPICAL PAINTED MEDIAN MARKING

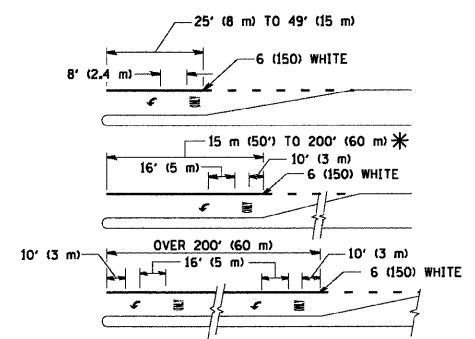
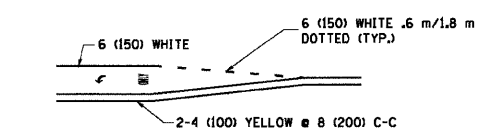

FULL SIZE LETTERS 8' (2.4 m) AND ARROWS SHALL BE USED.
AREA = 15.8 SQ. FT. (1.47 m²) ONLY AREA = 22.9 SQ. FT. (2.13 m²)
TURN LANES IN EXCESS OF 400' (120 m) IN LENGTH MAY HAVE AN ADDITIONAL SET OF ARROW - "ONLY" INSTALLED MIDWAY BETWEEN THE OTHER TWO SETS OF ARROW - "ONLY".

TYPICAL LEFT (OR RIGHT) TURN LANE

TYPICAL TURN LANE MARKING

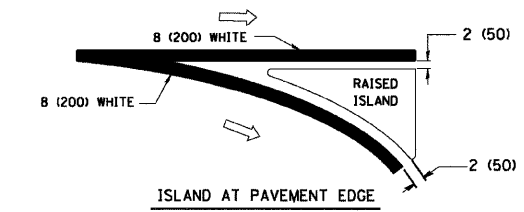
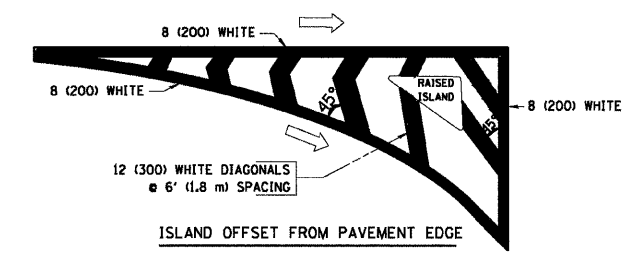

TYPICAL ISLAND MARKING

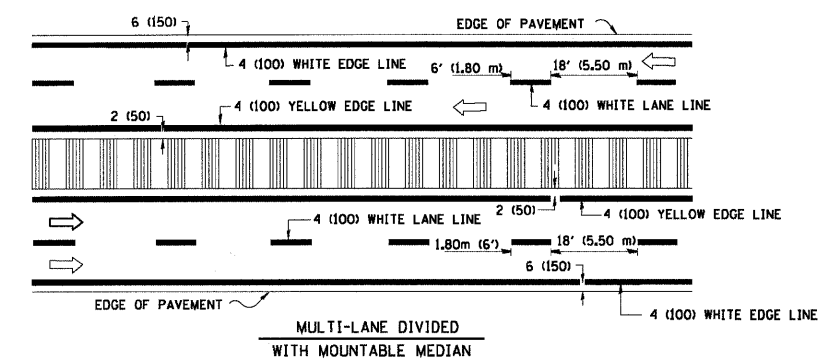
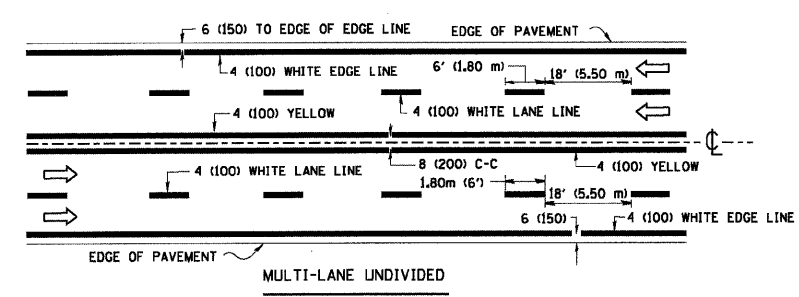

NOTE: MEDIANS WITH BARRIER CURB DO NOT REQUIRE AN EDGE LINE

TYPICAL LANE AND EDGE LINE MARKING

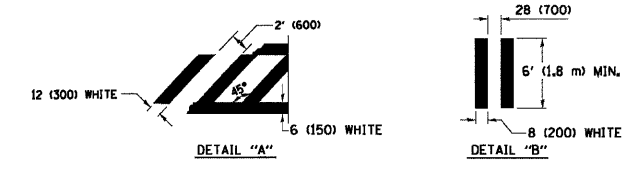
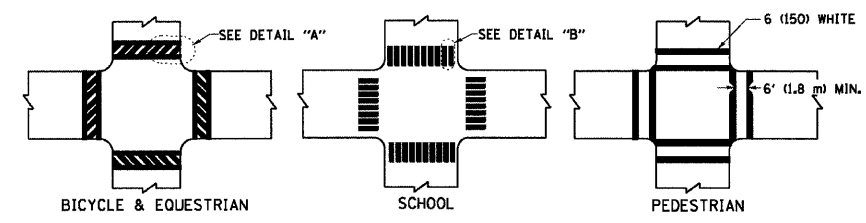

TYPICAL CROSSWALK MARKING

TYPE OF MARKING	WIDTH OF LINE	PATTERN	COLOR	SPACING / REMARKS
CENTERLINE ON 2 LANE PAVEMENT	4 (100)	SKIP-DASH	YELLOW	6' (1.80 m) LINE WITH 18' (5.50 m) SPACE
CENTERLINE ON MULTI-LANE UNDIVIDED PAVEMENT	2 @ 4 (100)	SOLID	YELLOW	8 (200) C-C
NO PASSING ZONE LINES FOR ONE DIRECTION FOR BOTH DIRECTIONS	4 (100) 2 @ 4 (100)	SOLID SOLID	YELLOW YELLOW	8 (200) C-C
LANE LINES	4 (100) 5 (125) ON FREEWAYS	SKIP-DASH SKIP-DASH	WHITE WHITE	6' (1.80 m) LINE WITH 18' (5.50 m) SPACE
DOTTED LINES (EXTENSIONS OF CENTER, LANE OR TURN LANE MARKINGS)	SAME AS LINE BEING EXTENDED	SKIP-DASH	SAME AS LINE BEING EXTENDED	2' (600) LINE WITH 6' (1.8) SPACE
EDGE LINES	4 (100)	SOLID	YELLOW-LEFT WHITE-RIGHT	OUTLINE MOUNTABLE MEDIANS IN YELLOW; EDGE LINES ARE NOT USED NEXT TO BARRIER CURB
TURN LANE MARKINGS	6 (150) LINE; FULL SIZE LETTERS & SYMBOLS (8' (2.4 m))	SOLID	WHITE	SEE TYPICAL TURN LANE MARKING DETAIL
TWO WAY LEFT TURN MARKING	2 @ 4 (100) EACH DIRECTION 8' (2.4 m) LEFT ARROW	SKIP-DASH AND SOLID IN PAIRS	YELLOW WHITE	6' (1.8 m) LINE WITH 18' (5.50 m) SPACE FOR SKIP-DASH; 8 (200) C-C BETWEEN SOLID LINE AND SKIP-DASH LINE SEE TYPICAL TWO-WAY LEFT TURN MARKING DETAIL
CROSSWALK LINES (PEDESTRIAN) A. DIAGONALS (BIKE & EQUESTRIAN) B. LONGITUDINAL BARS (SCHOOL)	2 @ 6 (150) 2' (600) APART 2'-4" (700) APART	SOLID SOLID SOLID	WHITE WHITE WHITE	NOT LESS THAN 6' (1.8 m) APART SEE TYPICAL CROSSWALK MARKING DETAILS.
STOP LINES	24 (600)	SOLID	WHITE	PLACE 4' (1.2 m) IN ADVANCE OF AND PARALLEL TO CROSSWALK, IF PRESENT. OTHERWISE, PLACE AT DESIRED STOPPING POINT. PARALLEL TO CROSSROAD CENTERLINE, WHERE POSSIBLE.
PAINTED MEDIANS	2 @ 4 (100) WITH 12 (300) DIAGONALS @ 45°	SOLID	YELLOW; TWO WAY TRAFFIC WHITE; ONE WAY TRAFFIC	8 (200) C-C FOR THE DOUBLE LINE SEE TYPICAL PAINTED MEDIAN MARKING.
GORE MARKING AND CHANNELIZING LINES	8 (200) WITH 12 (300) DIAGONALS @ 45°	SOLID	WHITE	DIAGONALS; 20' (6.1 m) (LESS THAN 30 MPH (50 km/h))
RAILROAD CROSSING	24 (600) TRANSVERSE LINES; "RR" IS 6' (1.8 m) LETTERS; 16 (400) LINE FOR "X"	SOLID	WHITE	SEE STATE STANDARD 780001 AREA OF: "R"=3.6 SQ. FT. (0.33m ²) EACH "X"=54.0 SQ. FT. (5.0 m ²)

FOR FURTHER DETAILS ON PAVEMENT MARKING REFER TO STREET MARKING STANDARDS, PRINTED BY CITY OF CHICAGO, DEPARTMENT OF TRANSPORTATION, BUREAU OF TRAFFIC.

ALL DIMENSIONS ARE IN INCHES (MILLIMETERS) UNLESS OTHERWISE SHOWN.

FILE NAME = W:\data\td\22x34\to24.dgn	USER NAME = geglennob	DESIGNED -	REVISED - T. RAMMACH 12-07-00
		DRAWN -	REVISED -
	PLOT SCALE = 50.000 / IN.	CHECKED -	REVISED -
	PLOT DATE = 1/4/2008	DATE -	REVISED -

STATE OF ILLINOIS
DEPARTMENT OF TRANSPORTATION

CITY OF CHICAGO			
TYPICAL PAVEMENT MARKINGS			
SCALE: NONE	SHEET NO. 1 OF 2 SHEETS	STA. TO STA.	

F.A. ILL. RTE.	SECTION	COUNTY	TOTAL SHEETS	SHEET NO.
2907	1Y (5.6 & 7) RS	COOK	17	16
TC-24			CONTRACT NO. 62404	
FED. ROAD DIST. NO. 1 ILLINOIS FED. AID PROJECT				

