

MILLED TEMPORARY RAMP  
(FOR BUTT JOINT AND HMA TAPER SEE DETAIL BELOW)

OPTION 1

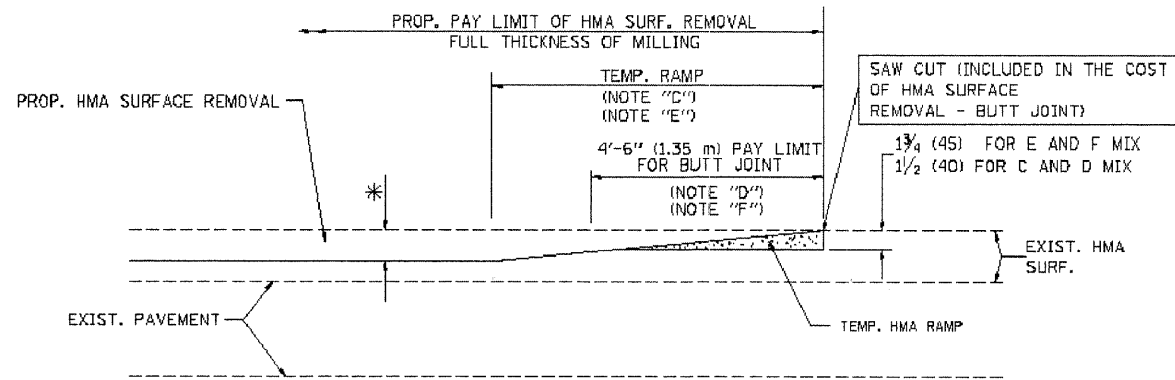

HMA CONSTRUCTED TEMPORARY RAMP  
(FOR BUTT JOINT AND HMA TAPER SEE DETAIL BELOW)

OPTION 2

TYPICAL TEMPORARY RAMP

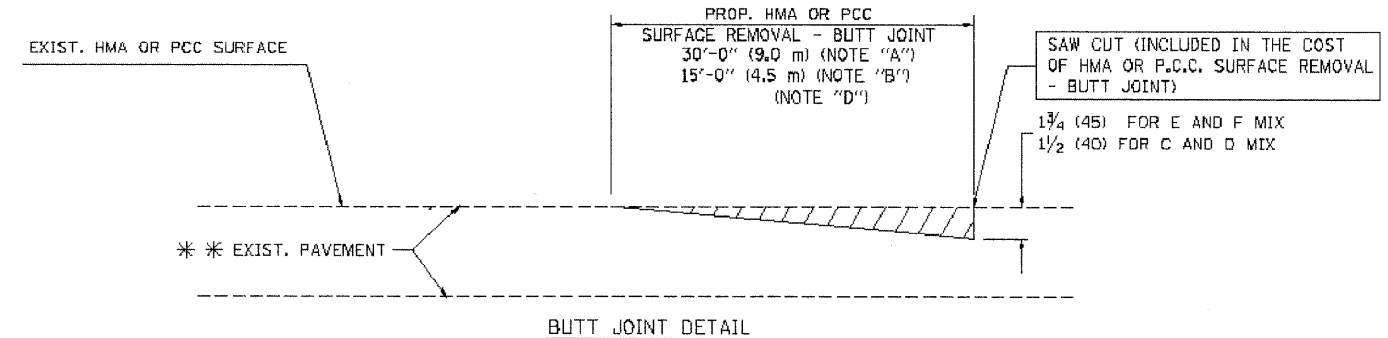

BUTT JOINT DETAIL

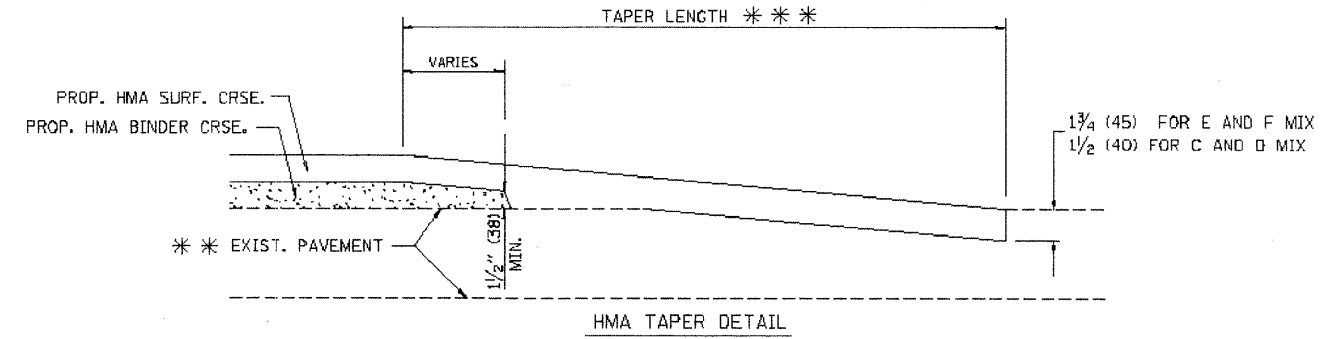

HMA TAPER DETAIL

TYPICAL BUTT JOINT AND HMA TAPER  
FOR RESURFACING ONLY

\*\*\* PC CONCRETE, HMA OR HMA RESURFACED PAVEMENT.

NOTES

- A: MAINLINE ROADWAYS AND MAJOR SIDE ROADS.
  - B: MINOR SIDE ROADS.
  - C: THE TEMP. RAMP SHALL BE CONSTRUCTED IMMEDIATELY UPON REMOVAL OF THE EXISTING HMA SURFACE.
  - D: THE BUTT JOINT SHALL BE CONSTRUCTED IMMEDIATELY PRIOR TO PLACING THE PROPOSED HMA COURSES.
  - E: TAPER THE TEMP. RAMP AT A RATE OF 3'-0" (900 mm) PER 1 INCH (25 mm) OF MILLING THICKNESS.
  - F: INSTALLATION AND REMOVAL OF THE 4'-6" (1.35 m) TEMP. RAMP IS INCLUDED IN COST OF HMA SURFACE REMOVAL - BUTT JOINT
  - G: SEE ARTICLE 406.08 AND 406.14 OF THE STANDARD SPECIFICATIONS FOR "HMA AND/OR PCC SURFACE REMOVAL, BUTT JOINT".
- \* SEE TYPICAL SECTIONS FOR MILLING THICKNESS.
- \*\*\* 20'-0" (6.1 m) PER 1 (25) RESURFACING (NOTE "A")  
10'-0" (3.0 m) PER 1 (25) RESURFACING (NOTE "B")

BASIS OF PAYMENT:

THE BUTT JOINT WILL BE PAID FOR AT THE CONTRACT UNIT PRICE PER SQUARE YARD (SQUARE METER) FOR "HOT-MIX ASPHALT SURFACE REMOVAL - BUTT JOINT" OR FOR "PORTLAND CEMENT CONCRETE SURFACE REMOVAL - BUTT JOINT".

ALL DIMENSIONS ARE IN INCHES (MILLIMETERS) UNLESS OTHERWISE SHOWN.

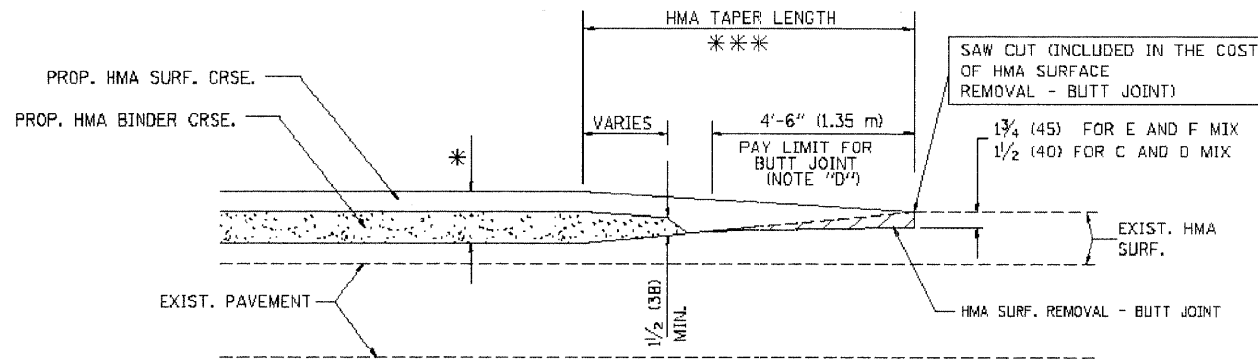

BUTT JOINT AND HMA TAPER

TYPICAL BUTT JOINT AND HMA TAPER  
FOR MILLING AND RESURFACING

Drawing file: W:\Projects\61209101 - Montrose LAPP (Cumb to Carfield)\MONTROS.dwg Jul 13, 2009 - 2:04pm

FILE NAME = W:\saratad\22e34\bd32.dgn	USER NAME = gaglisambt	DESIGNED - M. DE YONG	REVISED - R. SHAH 10-25-94
PLOT SCALE = 50.0000' / IN.	CHECKED -	REVISOR - A. ABBAS 03-21-97	REVISOR - M. GOMEZ 04-06-01
PLOT DATE = 1/4/2008	DATE - 06-13-90	REVISOR - R. BORO 01-01-07	

STATE OF ILLINOIS  
DEPARTMENT OF TRANSPORTATION

BUTT JOINT AND  
HMA TAPER DETAILS

SCALE: NONE SHEET NO. 1 OF 1 SHEETS STA. TO STA.

F.A. RTE.	SECTION	COUNTY	TOTAL SHEETS	SHEET NO.
2729	09-00056-00-RS	COOK	14	10
RD400-05 RD32		CONTRACT NO. 63256		
FED. ROAD DIST. NO. 1 ILLINOIS FED. AID PROJECT ARA-9003 (349)				
E.H.E. PROJECT NO. 612-09-10101				