

L₁ = DISTANCE FROM EDGE OF PAVEMENT TO RADIUS POINT OR MAX. DISTANCE 30'
 L₂ = DISTANCE FROM RADIUS POINT OR MAX DISTANCE 30' OFF EDGE OF PAVEMENT TO R.O.W. LINE.
 NOTE: MATERIAL USED TO CONSTRUCT L₂ LENGTH SHALL BE OF THE SAME TYPE OF MATERIAL AS EXISTING ENTRANCE.

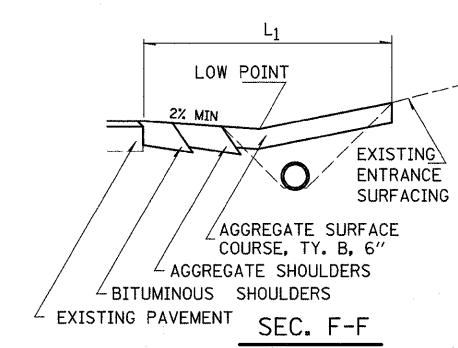

ENTRANCE SCHEDULE

TYPE	SIDE/ STATION	WIDTH	LENGTH		RADIUS	AGGREGATE BASE, CSE. TY. B, 6"		BITUMINOUS BASE COURSE, 8"	AGGREGATE SURF. CSE. TYPE B	INCIDENTAL BITUMINOUS SURFACING *	P.C.C. DRIVEWAY PAV'T		BIT. CONC. SURFACE COURSE	PCC PAVEMENT 8"
			L ₁	L ₂		TON	SQ. YD.				TON	SQ. YD.		
FE	289+21	20	24	34	20				42					
FE	289+50	24	28	30	24				51					
FE	308+59	20	24	38	20				44					
NORTH DITCH BANK ROAD														
FE	3+42.21	24	26	12	24				32					
TEMPORARY ENTRANCES FOR STAGING														
FE	286+50.00	15			SEE PLAN				167					
FE	313+00.00	15			SEE PLAN				232					

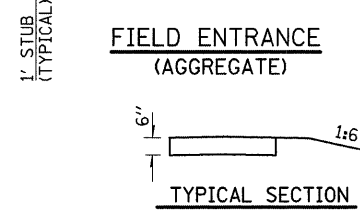
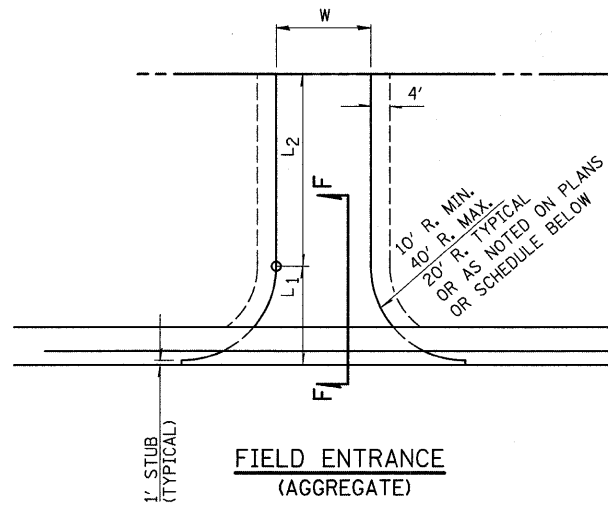
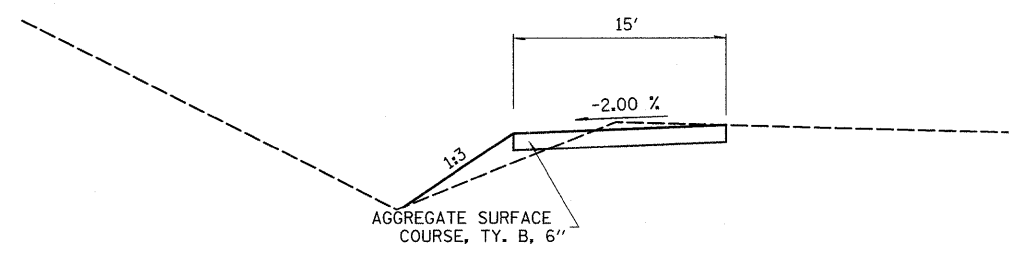

TEMPORARY ENTRANCE
STATION 286+50.00 RT.

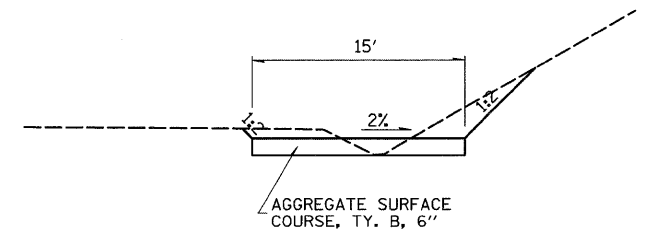

TEMPORARY ENTRANCE
STATION 313+00.00 LT.