

STATE OF ILLINOIS  
DEPARTMENT OF TRANSPORTATION  
DIVISION OF HIGHWAYS

PROPOSED  
HIGHWAY PLANS

F.A.I. ROUTE 70 (I-55/70)  
SECTION 60-(7,8,9,10)RS, 60-(8,9,10)BR  
PROJECT IM-070-1(183)011  
MADISON COUNTY

C-98-046-07  
RESURFACING, BRIDGE REHABILITATION

FOR INDEX OF SHEETS, SEE SHEET NO. 2

F.A.I. RTE.	SECTION	COUNTY	TOTAL SHEETS	SHEET NO.
70	60-(7,8,9,10)RS, 60-(8,9,10)BR	MADISON	150	1
FED. ROAD DIST. NO.	ILLINOIS			CONTRACT NO. 76A73

★ 150+2=152

D-98-044-07

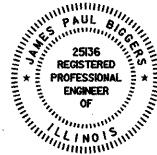

*James Paul Biggers*  
JAMES PAUL BIGGERS, P.E.

DATE 6/12/09  
LICENSE EXPIRES 11/30/09

PLANS PREPARED BY:



**JOHNSON, DEPP & QUISENBERRY**  
CONSULTING ENGINEERS  
6450 South Sixth Street Road, Suite B Springfield, Illinois 62712  
Phone: (217) 529-4534 Fax: (217) 529-8278

RESURFACING OMISSION  
STA. 791+96.66 TO STA. 793+95.11  
S.N. 060-0018/19  
STA. 792+96.00

RESURFACING OMISSION  
STA. 704+48.50 TO STA. 710+75.00  
S.N. 060-0269  
STA. 708+21.97

S.N. 060-0172  
STA. 665+88.58

RESURFACING OMISSION  
STA. 624+30.93 TO STA. 626+35.17  
STA. 625+31.29  
S.N. 060-0016/17 (NO WORK)

PROJECT BEGINS  
STA. 564+60

PROJECT ENDS  
STA. 1263+58

S.N. 060-0058  
STA. 1278+44

S.N. 060-0057  
STA. 1279+69

S.N. 060-0022  
STA. 913+23.71

RESURFACING OMISSION  
STA. 1351+13.53 TO  
STA. 1355+27.67  
(EX. P.C.C. PAVEMENT)

STATION EQUATION:  
STA. 856+00 BK. =  
STA. 1382+94 AH.

S.N. 060-0267  
STA. 833+50.90

STATION EQUATION:  
STA. 690+77.40 BK. =  
STA. 696+68.33 AH.

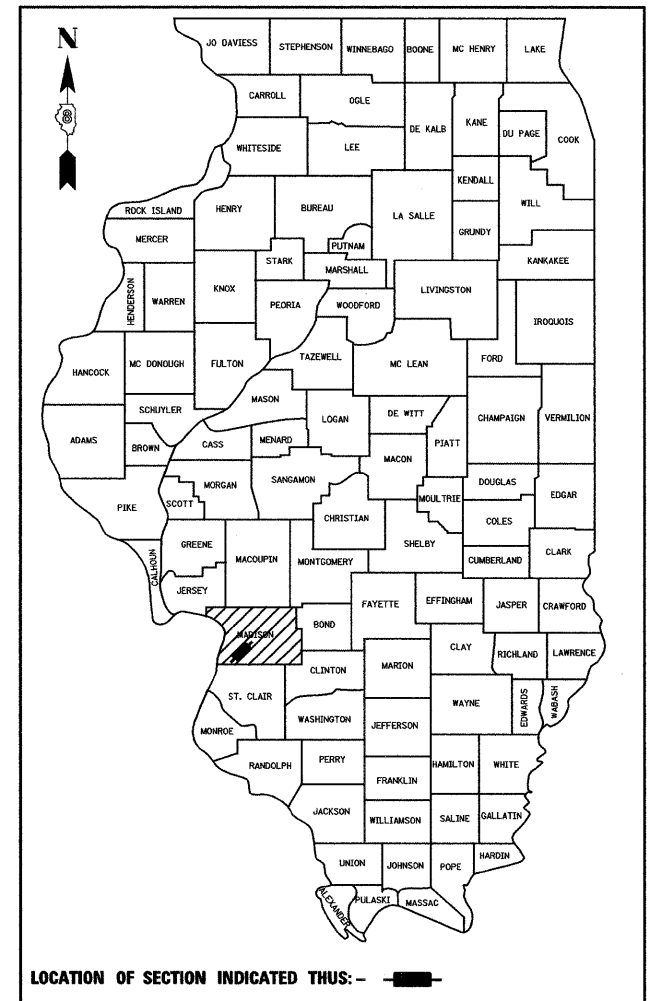

URBAN PRINCIPAL ARTERIAL (INTERSTATE)  
F.A.I. 70  
ADT (2005) = 39,400  
ADT (2030) = 50,500  
PV = 73.0% SU = 3.7% MU = 23.3%  
DESIGN SPEED = 70 MPH

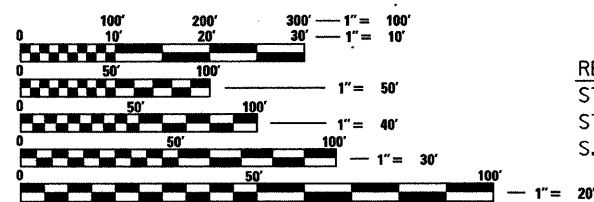

FULL SIZE PLANS HAVE BEEN PREPARED USING STANDARD ENGINEERING SCALES. REDUCED SIZED PLANS WILL NOT CONFORM TO STANDARD SCALES. IN MAKING MEASUREMENTS ON REDUCED PLANS, THE ABOVE SCALES MAY BE USED.

J.U.L.I.E.  
JOINT UTILITY LOCATION INFORMATION FOR EXCAVATION  
1-800-892-0123  
OR 811

PROJECT ENGINEER: PATTI LEBEAU (618)346-3179  
PROJECT MANAGER: CHERYL KEPLAR (618)346-3186  
CONTRACT NO. 76A73

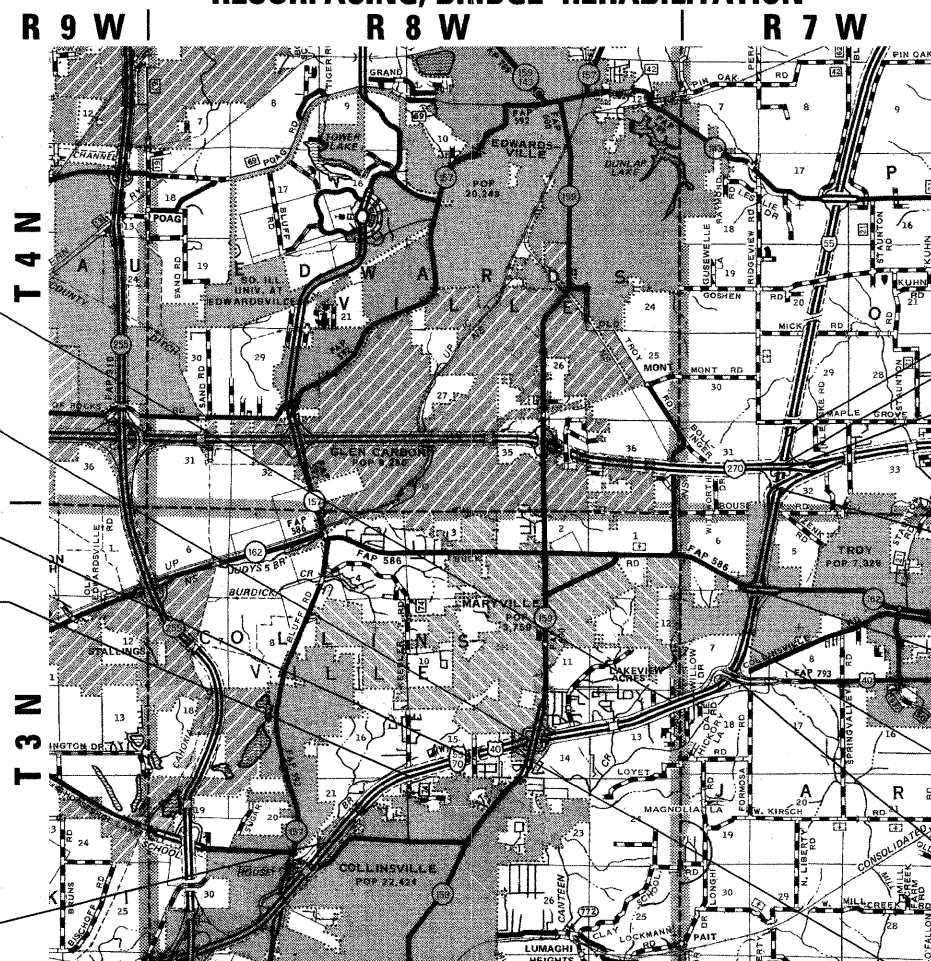

LOCATION MAP



GROSS LENGTH = 40,485.07 FEET = 7.668 MILES  
NET LENGTH = 39,240.19 FEET = 7.432 MILES

PRINTED BY THE AUTHORITY  
OF THE STATE OF ILLINOIS

STATE OF ILLINOIS  
DEPARTMENT OF TRANSPORTATION  
DIVISION OF HIGHWAYS

SUBMITTED *June 25, 2009*  
*Mary C. Lami*  
DEPUTY DIRECTOR OF HIGHWAYS, REGION 5 ENGINEER

*August 14, 2009*  
*Charles G. Ingersoll*  
ENGINEER OF DESIGN AND ENVIRONMENT

*August 14, 2009*  
*Christine M. Reed*  
DIRECTOR OF HIGHWAYS, CHIEF ENGINEER

# INDEX OF SHEETS

1	COVER SHEET
2A	INDEX OF SHEETS, HIGHWAY STANDARDS, GENERAL NOTES AND COMMITMENTS
3-7A	SUMMARY OF QUANTITIES
8-16	TYPICAL SECTIONS
17-21	SCHEDULES OF QUANTITIES
22-52	PLAN SHEETS
53-64	STAGES OF CONSTRUCTION AND TRAFFIC CONTROL
65-66	EROSION AND SEDIMENT CONTROL DETAILS
67-97	PAVEMENT MARKING DETAILS
98-120	STRUCTURAL DETAILS
121-124	MISCELLANEOUS DETAILS
125-130	SIGN PANEL DESIGNS
131	ENHANCED MILE MARKER DETAILS
132-150	ITS DETAILS

# HIGHWAY STANDARDS

000001-05	STANDARD SYMBOLS, ABBREVIATIONS AND PATTERNS
280001-04	TEMPORARY EROSION CONTROL SYSTEMS
353001-04	PCC BASE COURSE WITH HMA BINDER AND SURFACE COURSES
420701-02	PAVEMENT FABRIC
442101-07	CLASS B PATCHES
442201-03	CLASS C AND D PATCHES
601001-03	SUB-SURFACE DRAINS
601101-01	CONCRETE HEADWALL FOR PIPE DRAIN
630001-08	STEEL PLATE BEAM GUARDRAIL
630301-05	SHOULDER WIDENING FOR TYPE 1 (SPECIAL) GUARDRAIL TERMINALS
631011-05	TRAFFIC BARRIER TERMINAL, TYPE 2
631026-05	TRAFFIC BARRIER TERMINAL, TYPE 5
631031-07	TRAFFIC BARRIER TERMINAL, TYPE 6
631032-04	TRAFFIC BARRIER TERMINAL, TYPE 6A
631033-03	TRAFFIC BARRIER TERMINAL, TYPE 6B
635001-01	DELINEATORS
635006-03	REFLECTOR AND TERMINAL MARKER PLACEMENT
635011-02	REFLECTOR MARKER AND MOUNTING DETAILS
642001-01	SHOULDER RUMBLE STRIPS
701101-02	OFF-RD OPERATIONS, MULTILANE, 15' (4.5 m) TO 24' (600 mm) FROM PAVEMENT EDGE
701201-03	LANE CLOSURE, 2L, 2W, DAY ONLY, FOR SPEEDS ≥ 45 MPH
701400-03	APPROACH TO LANE CLOSURE, FREEWAY/EXPRESSWAY
701401-05	LANE CLOSURE, FREEWAY/EXPRESSWAY
701406-05	LANE CLOSURE, FREEWAY/EXPRESSWAY, DAY OPERATIONS ONLY
701411-05	LANE CLOSURE, MULTILANE, AT ENTRANCE OR EXIT RAMP, FOR SPEEDS ≥ 45 MPH
701426-03	LANE CLOSURE, MULTILANE, INTERMITTENT OR MOVING OPERATION, FOR SPEEDS ≥ 45 MPH
701456	PARTIAL EXIT RAMP CLOSURE FREEWAY/EXPRESSWAY
701601-06	URBAN LANE CLOSURE, MULTILANE, 1W OR 2W WITH NONTRAVERSABLE MEDIAN
701901-01	TRAFFIC CONTROL DEVICES
780001-02	TYPICAL PAVEMENT MARKING
781001-03	TYPICAL APPLICATIONS RAISED REFLECTIVE PAVEMENT MARKERS
814001-02	HANDHOLES
814006-02	DOUBLE HANDHOLES
878001-07	CONCRETE FOUNDATION DETAILS

# GENERAL NOTES

- THE STANDARDS AND REVISION NUMBERS LISTED SHALL APPLY TO THIS PROJECT.
- ILLINOIS STATE LAW REQUIRES A 48-HOUR NOTICE TO BE GIVEN TO UTILITIES BEFORE DIGGING. FIELD MARKING OF FACILITIES MAY BE OBTAINED BY CONTACTING J.U.L.I.E. OR FOR NON-MEMBERS, THE UTILITY COMPANY DIRECTLY. AGENCIES KNOWN TO HAVE FACILITIES WITHIN THE PROJECT AREA ARE AS FOLLOWS:

UTILITY CO.	TYPE
•AMEREN IP	GAS & ELECTRIC
•AT&T CORPORATION	COMMUNICATIONS
•AT&T ILLINOIS	COMMUNICATIONS
•CENTERPOINT ENERGY	PIPELINE
•CHARTER COMMUNICATIONS	CABLE TV
•CITY OF COLLINSVILLE	WATER & SAN. SEW.
•CITY OF TROY	WATER & SAN. SEW.
•KINDER MORGAN	PIPELINE
•LEVEL 3 COMMUNICATIONS	COMMUNICATIONS
•SW ELECTRIC COOP., INC.	ELECTRIC
•VILLAGE OF CASEYVILLE	WATER & SAN. SEW
•VILLAGE OF MARYVILLE	WATER & SAN. SEW

MEMBERS OF J.U.L.I.E. (800)-892-0123 ARE INDICATED BY \*. NON J.U.L.I.E. MEMBERS MUST BE NOTIFIED INDIVIDUALLY.

- THE THICKNESS OF THE HMA MIXTURE SHOWN ON THE PLANS IS THE NOMINAL THICKNESS. DEVIATIONS FROM THE NOMINAL THICKNESS WILL BE PERMITTED WHEN SUCH DEVIATIONS OCCUR DUE TO IRREGULARITIES IN THE EXISTING SURFACE OR BASE ON WHICH THE HMA MIXTURE IS PLACED.

- "ROAD CONSTRUCTION AHEAD" SIGNS SHALL BE PLACED AT RAMP, ENTRANCES AND SIDE STREETS WHERE WORK IS BEING CONDUCTED AS DIRECTED BY THE RESIDENT ENGINEER. ALL CONSTRUCTION SIGNS SHALL BE FLUORESCENT ORANGE 48". THIS SHALL BE INCLUDED IN THE COST OF THE TRAFFIC CONTROL AND PROTECTION.

THE FOLLOWING MIXTURE REQUIREMENTS ARE APPLICABLE FOR THIS PROJECT:

MIXTURE USE	POLY SURFACE	LEVEL BINDER	POLY BINDER	SHOULDERS <2.25"
AC/PG	SBS PG 76-22	PG 64-22	SBS PG 76-22	PG 64-22
RAP % (MAX)	0%	10%	10%	30%
DESIGN AIR VOIDS	4.0% @ Ndes=80	4.0% @ Ndes=90	4.0% @ Ndes=90	2.0% @ Ndes=30
MIX COMPOSITION (GRADATION MIXTURE)		IL 9.5	IL 19.0	Min Lift = 1.5"
FRICITION AGGREGATE	SMA	MIXTURE "C"	MIXTURE "B"	BAM

TOP LIFT SHOULDERS - DESIGN THIS MIX AT 2.0% VOIDS AND ADD ASPHALT TO REDUCE VOIDS TO 1.5%.

PLAN QUANTITIES FOR BITUMINOUS CONCRETE SURFACE COURSE ITEMS ARE CALCULATED USING A UNIT WEIGHT OF 112 LB/SQ YD/IN (59.8 KG/SQ M/25 mm THICKNESS).

- ALL AREAS DISTURBED FOR ANY REASON SHALL BE PERMANENTLY SEEDDED AS DIRECTED BY THE ENGINEER. ALL AREAS DISTURBED BY THE CONTACTOR OUTSIDE THE PROPOSED CONSTRUCTION LIMITS SHALL BE SEEDDED AT THE CONTACTOR'S EXPENSE. NUTRIENTS SHALL CONFORM TO ARTICLE 250.4, EXCEPT FERTILIZER NUTRIENTS WILL NOT BE PAID FOR SEPARATELY BUT CONSIDERED AS INCLUDED IN THE COST OF THE CLASS 2 SEEDING.

- QUANTITY FOR THE PIPE UNDERDRAIN 4" IS BASED ON THE TOTAL LENGTH OF THE PROJECT MULTIPLIED BY A FACTOR OF FOUR. PIPE UNDERDRAIN 4" SPECIAL QUANTITY IS BASED PER ARTICLE 601.04 OF THE STANDARD SPECIFICATIONS. OUTLETTED AT 500' SPACING AND A LENGTH OF 20' PER OUTLET. RAMP QUANTITIES ARE MULTIPLIED BY A FACTOR OF TWO.

- THIS SECTION CONTAINS TWO STATION EQUATIONS: PT STA. 690+77.40 BK= STA. 696+68.33 AH STA. 856+00.00 BK= STA. 1382+94.00 AH

- THE WEIGH STATION WITHIN THE LIMITS OF THIS PROJECT SHALL REMAIN OPEN DURING THE DURATION OF THIS CONTRACT. USE TRAFFIC CONTROL AND PROTECTION STANDARD 701411.

- SHOULDER WIDENING FOR THE TRAFFIC BARRIER TERMINAL TYPE 1, SPECIAL (TANGENT) SHALL BE INCLUDED IN THE UNIT PRICE OF THE TRAFFIC BARRIER TERMINAL TYPE 1, SPECIAL (TANGENT) AND CONSTRUCTED ACCORDING TO STANDARD 630301.

- ALL TEMPORARY PAVEMENT MARKING WILL BE PLACED IN SUCH A MANNER SO AS NOT TO INTERFERE WITH THE PLACEMENT OF PERMANENT PAVEMENT MARKINGS.

- MIXTURES FOR CRACKS, JOINTS AND FLANGWAYS AS SPECIFIED IN ARTICLE 406 OF THE STANDARD SPECIFICATIONS SHALL BE PAID FOR ACCORDING TO ARTICLE 109.04 OF THE STANDARD SPECIFICATIONS.

- MULCH, UNLESS OTHERWISE PERMITTED BY THE ENGINEER, SHALL CONFORM TO METHOD 2, PROCEDURE 2 AS SPECIFIED IN ARTICLE 251.03.

- THE WEIGH IN MOTION SLAB SHALL NOT BE RESURFACED, NOR DISTURBED IN ANYWAY. SEE PLAN SHEET FOR ADDITIONAL DETAILS.

- CHANGEABLE MESSAGE SIGNS TO BE INSTALLED (2 WEEKS) PRIOR TO CONSTRUCTION.

- TWO WEEKS PRIOR TO PROJECT START-UP CHANGEABLE MESSAGE SIGNS SHALL BE PLACED AT THE FOLLOWING LOCATIONS AS DIRECTED BY THE ENGINEER:

I-55/70 EB WEST OF I-255  
 I-55 SB NORTH OF 3-I  
 I-70 WB EAST OF 3-I  
 I-270 EB WEST OF 3-I  
 I-255 NB SOUTH OF I-55/70  
 I-255 SB NORTH OF I-55/70  
 IL 157 NB SOUTH OF I-55/70  
 IL 157 SB NORTH OF I-55/70  
 IL 159 NB SOUTH OF I-55/70  
 IL 159 SB NORTH OF I-55/70  
 IL 162 EB WEST OF I-55/70  
 IL 162 WB EAST OF I-55/70  
 US 40 WB EAST OF I-55/70

THE CONTRACTOR SHALL MODIFY THE MESSAGE ON EACH SIGN AS DIRECTED BY THE ENGINEER, AS NEEDED.

THE CONTRACTOR SHALL BE AWARE THAT THE MESSAGE BOARDS MAY REQUIRE RELOCATION THROUGHOUT THE DURATION OF PROJECT WITH NO ADDITIONAL COMPENSATION BEING ALLOWED FOR THE RELOCATION.

- THE CONTRACTOR SHALL BE AWARE THAT THE EXISTING CONCRETE PATCHES SHALL BE MILLED AS PART OF THE PROPOSED HMA SURFACE REMOVAL AND NO ADDITIONAL COMPENSATION WILL BE ALLOWED FOR THE MILLING OF THE CONCRETE.

- FOR STABILIZATION, ALL TYPE III BARRICADES SHALL REQUIRE A MINIMUM OF FOUR SANDBAGS PER BARRICADE.

- THE CONTRACTOR SHALL BE REQUIRED TO COMPLY WITH THE PROVISIONS OF THE NATIONAL POLLUTION DISCHARGE ELIMINATION SYSTEM (NPDES) STORM WATER PERMIT AND IMPLEMENT THE EROSION CONTROL PLAN INCLUDED IN THESE PLANS AND SPECIFIED HEREIN. AS SPECIFIED IN ARTICLE 107.23, THE ENGINEER MUST GIVE PRIOR APPROVAL BEFORE DISTURBANCE OF ANY AREA CAN BEGIN.

- THE DISTRICT EIGHT BUREAU OF OPERATIONS SHALL BE NOTIFIED AT LEAST 10 CALENDAR DAYS PRIOR TO PLACEMENT OF THE FINAL PAVEMENT MARKINGS.

- THE CONTRACTOR SHALL PROVIDE LABOR AND MATERIALS REQUIRED TO IMPRINT PAVEMENT STATION NUMBERS IN THE FINISHED SURFACE OF THE PAVEMENT AND/OR OVERLAY. THE NUMBERS SHALL BE APPROXIMATELY 3/4 INCHES WIDE, 5 INCHES HIGH AND 5/8 INCHES DEEP.

- THE CONTRACTOR AND THE ENGINEER SHALL BE AWARE THAT NO SURVEY WAS PERFORMED FOR THIS PROJECT. THE STATIONING AND TOPO SHOWN IN THE PLANS WAS CREATED USING MICROFILM AND FIELD MEASUREMENTS MADE BY DESIGN PERSONNEL. BOTH SHALL BE CONSIDERED APPROXIMATE.

- LOCATING UNDERGROUND CABLE HAS BEEN INCLUDED IN THESE PLANS FOR LOCATING ALL STATE FACILITIES ON STATE ROW SUCH AS HIGHWAY LIGHTING, ITS SYSTEMS, TRAFFIC COUNTERS, ETC.

- THE LENGTHS OF GUARDRAIL REMOVAL SPECIFIED INCLUDES THE ENTIRE RUN OF GUARDRAIL INCLUDING TRAFFIC BARRIER TERMINALS, ETC.

- THE ENGINEER SHALL SURVEY ALL GORE AREAS TO DETERMINE DRAINAGE PATTERNS. THE PROPOSED HMA SURFACING, SHALL BE PLACED TO PROVIDE FOR POSITIVE DRAINAGE AS DIRECTED BY THE ENGINEER.

- ALL MILLED AREAS SHALL BE RESURFACED WITH THE APPROPRIATE LEVEL BINDER OR BINDER COURSE PRIOR TO OPENING LANES TO TRAFFIC.

# COMMITMENTS

NONE

# PERTINENT INFORMATION

FAI 70  
 SECTION 60-9-I  
 MADISON COUNTY  
 CONTRACT NO. 76D07  
 REPLACES A PORTION OF FAI 70 (EB & WB LANES) UNDER IL 159  
 WITH CLASS A PATCH, TYPE IV, 14 INCH  
 ALL WORK TO BE COMPLETED BY 11/16/09

FILE NAME =	USER NAME = tebbemg	DESIGNED -	REVISED -	<b>STATE OF ILLINOIS DEPARTMENT OF TRANSPORTATION</b>	<b>INDEX OF SHEETS, HIGHWAY STANDARDS, GENERAL NOTES AND COMMITMENTS</b>				F.A.I. RTE.	SECTION	COUNTY	TOTAL SHEETS	SHEET NO.
C:\Documents and Settings\conoverp\Local Settings\Temporary Internet Files\Content.IE5\BRAWN\G148DRW\0876673-sht-gennote.dgn		DRAWN/G148DRW\0876673-sht-gennote.dgn	REVISED -		70		MADISON	150	2				
		CHECKED -	REVISED -		SCALE: ---- SHEET NO. OF SHEETS STA. ---- TO STA. ----				CONTRACT NO. 76A73				
		DATE -	REVISED -		FED. ROAD DIST. NO. ILLINOIS FED. AID PROJECT								



• 60-(7,8,9,10)RS, 60-(8,9,10)BR

# GENERAL NOTES

5. THE FOLLOWING MIXTURE REQUIREMENTS ARE APPLICABLE FOR THIS PROJECT:

MIXTURE USE	POLY SURFACE	LEVEL BINDER	POLY BINDER	SHOULDERS	INCIDENTAL SURF
AC/PG	SBS PG 76-22	PG 64-22	SBS PG 76-22	PG 64-22	PG 64-22
RAP % (MAX)	0%	10%	10%	30%	10%
DESIGN AIR VOIDS	4.0% @ Ndes=80	4.0% @ Ndes=90	4.0% @ Ndes=90	2.0% @ Ndes=30	4.0% @ Ndes=70
MIX COMPOSITION					
(GRADATION MIXTURE)		IL 9.5	IL 19.0		
FRICTION AGGREGATE	SMA	MIXTURE "C"	MIXTURE "B"	BAM	MIXTURE "C"

TOP LIFT SHOULDERS - DESIGN THIS MIX AT 2.0% VOIDS AND ADD ASPHALT TO REDUCE VOIDS TO 1.5%.

PLAN QUANTITIES FOR BITUMINOUS CONCRETE SURFACE COURSE ITEMS ARE CALCULATED USING A UNIT WEIGHT OF 112 LB/SQ YD/IN (59.8 KG/SQ M/25 mm THICKNESS).

FILE NAME = c:\pwork\FW100T\CONVERPJ\dms71873\d876a73-sht-plan.dgn		USER NAME = conoverpj DESIGNED - --- DRAWN - --- CHECKED - --- DATE - ---	REVISED - --- REVISED - --- REVISED - --- REVISED - ---	<b>STATE OF ILLINOIS</b> <b>DEPARTMENT OF TRANSPORTATION</b>	<b>INDEX OF SHEETS, HIGHWAY STANDARDS,</b> <b>GENERAL NOTES AND COMMITMENTS</b>	F.A.I. RTE. 70	SECTION •	COUNTY MADISON	TOTAL SHEETS 150	SHEET NO. 2A	CONTRACT NO. <b>76873</b>
		PLOT SCALE = 50.0000' / IN. PLOT DATE = 7/10/2009			SCALE: ---	SHEET NO. ___ OF ___ SHEETS	STA. ---- TO STA. ----	FED. ROAD DIST. NO. - [ILLINOIS] FED. AID PROJECT			

• 60-(7,8,9,10)RS, 60-(8,9,10)BR

# SUMMARY OF QUANTITIES

SUMMARY OF QUANTITIES			URBAN 90/10 FIB/ST TOTAL QUANTITIES	CONSTRUCTION TYPE CODE								
				MAINLINE ROADWAY 1000	TR 162 E 060-0172 SFTY-2A	IL 159 060-0269 SFTY-2A	I-55/70 060-0018/19 SFTY-2A	US 40 060-0267 SFTY-2A	I-70 WB 060-0022 SFTY-2A	I-270 EB/WB 060-0057/58 SFTY-2A	SIGNS Y002-1C	ITS Y032-1F
CODE NO	ITEM	UNIT										
20100500	TREE REMOVAL, ACRES	ACRE	6.82	6.82								
20400800	FURNISHED EXCAVATION	CU YD	105	105								
21400100	GRADING AND SHAPING DITCHES	FOOT	900	900								
25000200	SEEDING, CLASS 2	ACRE	7.07	7.07								
25100115	MULCH, METHOD 2	ACRE	7.07	7.07								
28000250	TEMPORARY EROSION CONTROL SEEDING	POUND	707	707								
28100101	STONE RIPRAP, CLASS A1	SQ YD	12			12						
28100107	STONE RIPRAP, CLASS A4	SQ YD	261	261								
28100705	STONE DUMPED RIPRAP, CLASS A3	SQ YD	178	178								
28200200	FILTER FABRIC	SQ YD	273	261		12						
31100700	SUB-BASE GRANULAR MATERIAL, TYPE A 8"	SQ YD	3407	3407								
35300720	PORTLAND CEMENT CONCRETE BASE COURSE 13"	SQ YD	2904	2904								
40600200	BITUMINOUS MATERIALS (PRIME COAT)	TON	134.4	134.4								
40600300	AGGREGATE (PRIME COAT)	TON	641.8	641.8								
40600647	LEVELING BINDER (MACHINE METHOD), IL-9.5FG, N90	TON	2908	2908								
40600895	CONSTRUCTING TEST STRIP	EACH	2	2								
40600982	HOT-MIX ASPHALT SURFACE REMOVAL - BUTT JOINT	SQ YD	928	928								
40600990	TEMPORARY RAMP	SQ YD	1152	1152								
40603240	POLYMERIZED HOT-MIX ASPHALT BINDER COURSE, IL-19.0, N90	TON	29019	29019								
40800050	INCIDENTAL HOT-MIX ASPHALT SURFACING	TON	21	21								
44000153	HOT-MIX ASPHALT SURFACE REMOVAL, 1"	SQ YD	35912	35912								
44000158	HOT-MIX ASPHALT SURFACE REMOVAL, 2 1/4"	SQ YD	239616	239616								
44000161	HOT-MIX ASPHALT SURFACE REMOVAL, 3"	SQ YD	15681	15681								
44000198	HOT-MIX ASPHALT SURFACE REMOVAL, VARIABLE DEPTH	SQ YD	1286	1286								
44004250	PAVED SHOULDER REMOVAL	SQ YD	2341	2341								
44201031	CLASS B PATCHES, TYPE II, 15 INCH	SQ YD	77.1	77.1								
44201035	CLASS B PATCHES, TYPE III, 15 INCH	SQ YD	330	330								
44201037	CLASS B PATCHES, TYPE IV, 15 INCH	SQ YD	350.1	350.1								
44201903	CLASS D PATCHES, TYPE III, 21 INCH	SQ YD	40	40								
44213100	PAVEMENT FABRIC	SQ YD	680.1	680.1								
44213200	SAW CUTS	FOOT	2294	2294								
45200300	JOINT OR CRACK FILLING	POUND	192		36	156						

\*60-(7,8,9,10)RS, 60-(8,9,10)BR

FILE NAME =	USER NAME = conoverpj	DESIGNED -	REVISED -	<b>STATE OF ILLINOIS DEPARTMENT OF TRANSPORTATION</b>	<b>SUMMARY OF QUANTITIES</b>	F.A.I. RTE. 70	SECTION •	COUNTY MADISON	TOTAL SHEETS 150	SHEET NO. 3
ct:\pwwork\KPI\WIDOT\CONOVERPJ\dms71873\d76a73-shr-plan.dgn	76a73-shr-plan.dgn	DRAWN -	REVISED -			CONTRACT NO. 76A73				
PLOT SCALE = 58.0000' / IN.		CHECKED -	REVISED -		SCALE: _____	SHEET NO. 1 OF 6 SHEETS		STA. _____ TO STA. _____		
PLOT DATE = 6/25/2009		DATE -	REVISED -		FED. ROAD DIST. NO. - ILLINOIS FED. AID PROJECT					



# SUMMARY OF QUANTITIES

SUMMARY OF QUANTITIES			URBAN 90/10 FED/ST TOTAL	CONSTRUCTION TYPE CODE								
CODE NO	ITEM	UNIT	QUANTITIES	MAINLINE ROADWAY 1000	TR 162 E 060-0172 SFTY-2A	IL 159 060-0269 SFTY-2A	I-55/70 060-0018/19 SFTY-2A	US 40 060-0267 SFTY-2A	I-70 WB 060-0022 SFTY-2A	I-270 EB/WB 060-0057/58 SFTY-2A	SIGNS Y002-1C	ITS Y032-1F
48101200	AGGREGATE SHOULDERS, TYPE B	TON	2361	2361								
48203029	HOT-MIX ASPHALT SHOULDERS, 8"	SQ YD	2075	2075								
48203100	HOT-MIX ASPHALT SHOULDERS	TON	17909	17909								
50104650	SLOPE WALL REMOVAL	SQ YD	2				2					
50105225	PIPE CULVERT REMOVAL (SPECIAL)	FOOT	50	50								
50200100	STRUCTURE EXCAVATION	CU YD	3					3				
50500405	FURNISHING AND ERECTING STRUCTURAL STEEL	POUND	3260		3260							
50500715	JACK AND REMOVE EXISTING BEARINGS	EACH	16		16							
51100100	SLOPE WALL 4 INCH	SQ YD	2				2					
52000340	NEOPRENE EXPANSION JOINT 4"	FOOT	178						178			
52100010	ELASTOMERIC BEARING ASSEMBLY, TYPE I	EACH	16		16							
52100520	ANCHOR BOLTS, 1"	EACH	72		40					32		
54213669	PRECAST REINFORCED CONCRETE FLARED END SECTIONS 24"	EACH	1	1								
54247130	GRATING FOR CONCRETE FLARED END SECTION 24"	EACH	1	1								
54248510	CONCRETE COLLAR	CU YD	1					1				
58700300	CONCRETE SEALER	SQ FT	72692		6448	31976	14652	19616				
59200101	BRIDGE WASHING NO. 1	EACH	1		1							
59200102	BRIDGE WASHING NO. 2	EACH	1			1						
59200103	BRIDGE WASHING NO. 3	EACH	1				1					
59200104	BRIDGE WASHING NO. 4	EACH	1				1					
59200105	BRIDGE WASHING NO. 5	EACH	1					1				
59200106	BRIDGE WASHING NO. 6	EACH	1						1			
59200107	BRIDGE WASHING NO. 7	EACH	1							1		
59200108	BRIDGE WASHING NO. 8	EACH	1							1		
59300100	CONTROLLED LOW-STRENGTH MATERIAL	CU YD	10				6	4				
60100060	CONCRETE HEADWALL FOR PIPE DRAINS	EACH	384	384								
60100074	SHOULDER REMOVAL AND REPLACEMENT 8"	FOOT	36330	36330								
60107600	PIPE UNDERDRAINS 4"	FOOT	191580	191580								
60108100	PIPE UNDERDRAINS 4" (SPECIAL)	FOOT	7660	7660								
60260100	INLETS TO BE ADJUSTED	EACH	2	2								
* 63000001	STEEL PLATE BEAM GUARD RAIL, TYPE A, 6 FOOT POSTS	FOOT	23237.5	23237.5								
* 63100045	TRAFFIC BARRIER TERMINAL, TYPE 2	EACH	24	24								
* 63100070	TRAFFIC BARRIER TERMINAL, TYPE 5	EACH	3	3								

\* SPECIALTY ITEM

\*60-(7,8,9,10)RS, 60-(8,9,10)BR

FILE NAME =	USER NAME = conoverpj	DESIGNED -	REVISED -	<b>STATE OF ILLINOIS DEPARTMENT OF TRANSPORTATION</b>	<b>SUMMARY OF QUANTITIES</b>	F.A.I. RTE.	SECTION	COUNTY	TOTAL SHEETS	SHEET NO.
ca:\pwwork\PIWIDOT\CONOVERPJ\dms71073\d876e73-sht-plan.dgn	76e73-sht-plan.dgn	DRAWN -	REVISED -			70	.	MADISON	150	4
PLOT SCALE = 50.0000' / IN.		CHECKED -	REVISED -							
PLOT DATE = 6/25/2009		DATE -	REVISED -			SCALE: _____	SHEET NO. 2 OF 6 SHEETS	STA. _____	TO STA. _____	FED. ROAD DIST. NO. _____ ILLINOIS FED. AID PROJECT
<b>CONTRACT NO. 76A73</b>										

# SUMMARY OF QUANTITIES

SUMMARY OF QUANTITIES			CONSTRUCTION TYPE CODE									
			URBAN 90/10 FED/ST TOTAL QUANTITIES	MAINLINE ROADWAY 1000	TR 162 E 060-0172 SFTY-2A	IL 159 060-0269 SFTY-2A	I-55/70 060-0018/19 SFTY-2A	US 40 060-0267 SFTY-2A	I-70 WB 060-0022 SFTY-2A	I-270 EB/WB 060-0057/58 SFTY-2A	SIGNS Y002-1C	ITS Y032-1F
CODE NO	ITEM	UNIT										
* 63100085	TRAFFIC BARRIER TERMINAL, TYPE 6	EACH	6	6								
* 63100087	TRAFFIC BARRIER TERMINAL, TYPE 6A	EACH	3	3								
* 63100089	TRAFFIC BARRIER TERMINAL, TYPE 6B	EACH	9	9								
* 63100167	TRAFFIC BARRIER TERMINAL, TYPE 1 (SPECIAL) TANGENT	EACH	36	36								
63200310	GUARDRAIL REMOVAL	FOOT	20032	20032								
63500105	DELINEATORS	EACH	877	877								
63500120	DELINEATOR REMOVAL	EACH	877	877								
64200105	SHOULDER RUMBLE STRIP	FOOT	140153	140153								
66500105	WOVEN WIRE FENCE, 4'	FOOT	4700	4700								
66500305	WOVEN WIRE GATES, 4' X 4' SINGLE	EACH	1	1								
67000400	ENGINEER'S FIELD OFFICE, TYPE A	CAL MO	12	12								
67100100	MOBILIZATION	L SUM	1	1								
70100420	TRAFFIC CONTROL AND PROTECTION, STANDARD 701411	EACH	27	27								
70100450	TRAFFIC CONTROL AND PROTECTION, STANDARD 701201	L SUM	1	1								
70100700	TRAFFIC CONTROL AND PROTECTION, STANDARD 701406	L SUM	1	1								
70100800	TRAFFIC CONTROL AND PROTECTION, STANDARD 701401	L SUM	1	1								
70100825	TRAFFIC CONTROL AND PROTECTION, STANDARD 701456	L SUM	1	1								
70103815	TRAFFIC CONTROL SURVEILLANCE	CAL DA	120	120								
70106301	TRAFFIC CONTROL AND PROTECTION, STANDARD 701601, LOCATION 1	L SUM	1	1								
70106302	TRAFFIC CONTROL AND PROTECTION, STANDARD 701601, LOCATION 2	L SUM	1	1								
70106800	CHANGEABLE MESSAGE SIGN	CAL MO	156	156								
70300100	SHORT-TERM PAVEMENT MARKING	FOOT	22104	22104								
70300220	TEMPORARY PAVEMENT MARKING - LINE 4"	FOOT	35979	35979								
70300240	TEMPORARY PAVEMENT MARKING - LINE 6"	FOOT	164263	164263								
70300250	TEMPORARY PAVEMENT MARKING - LINE 8"	FOOT	17704	17704								
70300260	TEMPORARY PAVEMENT MARKING - LINE 12"	FOOT	484	484								
70300280	TEMPORARY PAVEMENT MARKING - LINE 24"	FOOT	16	16								
70301000	WORK ZONE PAVEMENT MARKING REMOVAL	SQ FT	108900	108900								

\* SPECIALTY ITEM

\*60-(7,8,9,10)RS, 60-(8,9,10)BR

FILE NAME =	USER NAME = conoverpj	DESIGNED -	REVISED -	<b>STATE OF ILLINOIS DEPARTMENT OF TRANSPORTATION</b>	<b>SUMMARY OF QUANTITIES</b>	F.A.I. RTE. TO	SECTION •	COUNTY MADISON	TOTAL SHEETS 150	SHEET NO. 5
cr:\pw\work\p\WIDOT\CONOVERPJ\dms71073\d876a73-sht-plan.dgn		DRAWN -	REVISED -							
PLOT SCALE = 50.0000' / 1" IN.		CHECKED -	REVISED -							
PLOT DATE = 6/25/2009		DATE -	REVISED -			SCALE: _____	SHEET NO. 3 OF 6 SHEETS	STA. _____	TO STA. _____	FED. ROAD DIST. NO. - ILLINOIS FED. AID PROJECT
								<b>CONTRACT NO. 76A73</b>		

# SUMMARY OF QUANTITIES

SUMMARY OF QUANTITIES			URBAN 90/10 FED/ST TOTAL QUANTITIES	CONSTRUCTION TYPE CODE								
				MAINLINE ROADWAY 1000	TR 162 E 060-0172 SFTY-2A	IL 159 060-0269 SFTY-2A	I-55/70 060-0018/19 SFTY-2A	US 40 060-0267 SFTY-2A	I-70 WB 060-0022 SFTY-2A	I-270 EB/WB 060-0057/58 SFTY-2A	SIGNS Y002-1C	ITS Y032-1F
CODE NO	ITEM	UNIT										
72000300	SIGN PANEL - TYPE 3	SQ FT	4477.75									4477.75
72400330	REMOVE SIGN PANEL - TYPE 3	SQ FT	4477.75									4477.75
<del>73300100</del>	<del>OVERHEAD SIGN STRUCTURE - SPAN, TYPE II-A (4'-6" X 4'-6")</del>	<del>FOOT</del>	<del>60</del>									<del>60</del>
73300200	OVERHEAD SIGN STRUCTURE - SPAN, TYPE II-A (4'-6" X 5'-3")	FOOT	60									60
<del>73400200</del>	<del>DRILLED SHAFT CONCRETE FOUNDATIONS</del>	<del>CU YD</del>	<del>20.4</del>									<del>20.4</del>
73600100	REMOVE OVERHEAD SIGN STRUCTURE - SPAN	EACH	2									2
<del>73700300</del>	<del>REMOVE CONCRETE FOUNDATION - OVERHEAD</del>	<del>EACH</del>	<del>1</del>									<del>1</del>
78000100	THERMOPLASTIC PAVEMENT MARKING - LETTERS AND SYMBOLS	SQ FT	664	664								
78000200	THERMOPLASTIC PAVEMENT MARKING - LINE 4"	FOOT	34881	34881								
78000400	THERMOPLASTIC PAVEMENT MARKING - LINE 6"	FOOT	157520	157520								
78000500	THERMOPLASTIC PAVEMENT MARKING - LINE 8"	FOOT	16567	16567								
78000600	THERMOPLASTIC PAVEMENT MARKING - LINE 12"	FOOT	484	484								
78000650	THERMOPLASTIC PAVEMENT MARKING - LINE 24"	FOOT	16	16								
78003130	PREFORMED PLASTIC PAVEMENT MARKING, TYPE B - LINE 6"	FOOT	20710	20710								
78003140	PREFORMED PLASTIC PAVEMENT MARKING, TYPE B - LINE 8"	FOOT	230	230								
78008210	POLYUREA PAVEMENT MARKING TYPE I - LINE 4"	FOOT	1098	1098								
78008230	POLYUREA PAVEMENT MARKING TYPE I - LINE 6"	FOOT	6743	6743								
78008240	POLYUREA PAVEMENT MARKING TYPE I - LINE 8"	FOOT	1137	1137								
78100100	RAISED REFLECTIVE PAVEMENT MARKER	EACH	2332	2332								
78100105	RAISED REFLECTIVE PAVEMENT MARKER (BRIDGE)	EACH	16	16								
78200410	GUARDRAIL MARKERS, TYPE A	EACH	212	212								
78201000	TERMINAL MARKER - DIRECT APPLIED	EACH	36	36								
78300200	RAISED REFLECTIVE PAVEMENT MARKER REMOVAL	EACH	1276	1276								
80300100	LOCATING UNDERGROUND CABLE	FOOT	83430	80970								2460
80500100	SERVICE INSTALLATION, TYPE A	EACH	11									11
81012500	CONDUIT IN TRENCH, 1 1/2" DIA., PVC	FOOT	2670									2670
81012800	CONDUIT IN TRENCH, 3" DIA., PVC	FOOT	130									130

\* SPECIALTY ITEM

Rev.

\*60-(7,8,9,10)RS, 60-(8,9,10)BR

Rev.

FILE NAME =	USER NAME = conoverpj	DESIGNED -	REVISED -	<b>STATE OF ILLINOIS DEPARTMENT OF TRANSPORTATION</b>	<b>SUMMARY OF QUANTITIES</b>	F.A.I. RTE.	SECTION	COUNTY	TOTAL SHEETS	SHEET NO.
ca:\pwork\NIDOT\CONVERPJ\dms71873\d78a73-sht-plen.dgn		DRAWN -	REVISED -			TO		MADISON	150	6
PLOT SCALE = 50.0000' / IN.	CHECKED -	REVISED -				SCALE: _____		SHEET NO. 4 OF 6 SHEETS		STA. _____ TO STA. _____
PLOT DATE = 6/25/2009	DATE -	REVISED -				FED. ROAD DIST. NO. - ILLINOIS FED. AID PROJECT				
						CONTRACT NO. 76A73				

# SUMMARY OF QUANTITIES

SUMMARY OF QUANTITIES			URBAN 90/10 FED/ST TOTAL QUANTITIES	CONSTRUCTION TYPE CODE								
CODE NO	ITEM	UNIT		MAINLINE ROADWAY 1000	TR 162 E 060-0172 SFTY-2A	IL 159 060-0269 SFTY-2A	I-55/70 060-0018/19 SFTY-2A	US 40 060-0267 SFTY-2A	I-70 WB 060-0022 SFTY-2A	I-270 EB/WB 060-0057/58 SFTY-2A	SIGNS Y002-1C	ITS Y032-1F
81018400	CONDUIT PUSHED, 1 1/2" DIA., GALVANIZED STEEL	FOOT	385									385
81400700	HANDHOLE, PORTLAND CEMENT CONCRETE	EACH	14									14
81400720	DOUBLE HANDHOLE, PORTLAND CEMENT CONCRETE	EACH	11									11
81702130	ELECTRIC CABLE IN CONDUIT, 600V (XLP-TYPE USE) 1/C NO. 6	FOOT	1344									1344
81900200	TRENCH AND BACKFILL FOR ELECTRICAL WORK	FOOT	2800									2800
83012400	LIGHT POLE, ALUMINUM, 45 FT. M.H., TENON MOUNT	EACH	3									3
83600200	LIGHT POLE FOUNDATION, 24" DIAMETER	FOOT	146									146
84200500	REMOVAL OF EXISTING LIGHTING UNIT, SALVAGE	EACH	14								14	
86300305	CONTROLLER CABINET TYPE III, SPECIAL	EACH	11									11
87000105	ELECTRIC CABLE ASSEMBLY IN CONDUIT, 600V (EPR-TYPE TC) 2/C NO. 10 AND NO. 10 GROUND	FOOT	330									330
87301715	ELECTRIC CABLE IN CONDUIT, COMMUNICATION NO. 18 6 PAIR	FOOT	240									240
87800210	CONCRETE FOUNDATION, TYPE D (SPECIAL)	FOOT	44									44
X0321743	SILICONE JOINT SEALER, 1"	FOOT	228			228						
X0322729	MATERIAL TRANSFER DEVICE	TON	62013	62013								
X0322935	PIPE CULVERTS TO BE CLEANED	EACH	1	1								
X0323077	SILICONE JOINT SEALER, 2 3/4"	FOOT	212							212		
X0323150	JUNCTION BOX, ALUMINUM, ATTACHED TO STRUCTURE, 18" X 18" X 10"	EACH	11									11
X0324632	SILICONE JOINT SEALER (SPECIAL)	FOOT	46					46				
X0325476	RADAR VEHICLE DETECTION SYSTEM	EACH	11									11
X0326091	LIGHT POLE, STEEL 50 FT. WITH CAMERA LOWERING SYSTEM	EACH	8									8
X0349800	CONCRETE HEADWALL FOR PIPE UNDERDRAIN REMOVAL	EACH	384	384								
X4066580	POLYMERIZED HOT-MIX ASPHALT SURFACE COURSE, STONE MATRIX ASPHALT, N80	TON	32994	32994								
X4400220	CURB REMOVAL AND REPLACEMENT	FOOT	1545	1545								
X7330105	OVERHEAD SIGN STRUCTURE WALKWAY, TYPE A	FOOT	30								30	
X8100065	CONDUIT IN TRENCH, 4" DIA., PVC TYPE C	FOOT	330									330
Z0005300	BOX CULVERTS TO BE CLEANED	EACH	1	1								
Z0017202	DOWEL BARS 1 1/2"	EACH	623	623								
Z0029999	IMPACT ATTENUATOR REMOVAL	EACH	4	4								

△ NON-PART (100% STATE)

\* SPECIALTY ITEM

Rev.

\*60-(7,8,9,10)RS, 60-(8,9,10)BR

FILE NAME =	USER NAME = conoverpj	DESIGNED -	REVISED -	<b>STATE OF ILLINOIS DEPARTMENT OF TRANSPORTATION</b>	<b>SUMMARY OF QUANTITIES</b>	F.A.I. RTE.	SECTION	COUNTY	TOTAL SHEETS	SHEET NO.	
es:\pwwork\PIWIDOT\CONOVERPJ\dms71073\d876a73-shd-plan.dgn	76a73-shd-plan.dgn	DRAWN -	REVISED -			TO		MADISON	150	7	
PLOT SCALE = 50,0000' / IN.		CHECKED -	REVISED -								CONTRACT NO. 76A73
PLOT DATE = 6/25/2009		DATE -	REVISED -			SCALE: _____	SHEET NO. 5 OF 6 SHEETS	STA. _____	TO STA. _____	FED. ROAD DIST. NO. - [ILLINOIS] FED. AID PROJECT	

# SUMMARY OF QUANTITIES

SUMMARY OF QUANTITIES			URBAN 90/10 FED/ST TOTAL	CONSTRUCTION TYPE CODE								
CODE NO	ITEM	UNIT	QUANTITIES	MAINLINE ROADWAY 1000	TR 162 E 060-0172 SFTY-2A	IL 159 060-0269 SFTY-2A	I-55/70 060-0018/19 SFTY-2A	US 40 060-0267 SFTY-2A	I-70 WB 060-0022 SFTY-2A	I-270 EB/WB 060-0057/58 SFTY-2A	SIGNS Y002-1C	ITS Y032-1F
Z0030150	IMPACT ATTENUATORS (NON-REDIRECTIVE), TEST LEVEL 3	EACH	4	4								
Z0040530	PIPE UNDERDRAIN REMOVAL	FOOT	199240	199240								
Z0050900	REMOVE CONCRETE FOUNDATION	EACH	6	6								
Z0075310	TIE BARS 3/4"	EACH	1330	1330								
Z0076600	TRAINEEES	HOUR	2500	2500								
60100081	SHOULDER REMOVAL AND REPLACEMENT 12"	FOOT	155055	155055								
* X0326678	REPLACE CATHODIC PROTECTION RECTIFIER	EACH	1							1		
* X0325922	CELLULAR MODEM	EACH	11	11								
* 81100800	CONDUIT ATTACHED TO STRUCTURE, 3" DIA., GALVANIZED STEEL	FOOT	20									20
* 72000100	SIGN PANEL - TYPE I	SQ FT	585								585	
* 72900200	METAL POST - TYPE B	FOOT	624								624	

© Y080 \* SPECIALTY ITEM

Rev.

\*60-(7,8,9,10)RS, 60-(8,9,10)BR

FILE NAME =	USER NAME = conoverpj	DESIGNED -	REVISED -	<b>STATE OF ILLINOIS DEPARTMENT OF TRANSPORTATION</b>	<b>SUMMARY OF QUANTITIES</b>	F.A.I. RTE.	SECTION	COUNTY	TOTAL SHEETS	SHEET NO.
er:\pwork\PIWIDOT\CONOVERPJ\dms71873\d876a73-sht-pln.dgn	76a73-sht-pln.dgn	DRAWN -	REVISED -			70	.	MADISON	150	7A
PLOT SCALE = 50.0000' / IN.	CHECKED -	REVISED -	REVISED -			CONTRACT NO. 76A73				
PLOT DATE = 6/25/2009	DATE -	REVISED -	REVISED -		SCALE: _____	SHEET NO. 6 OF 6 SHEETS		STA. _____ TO STA. _____		
FED. ROAD DIST. NO. - [ILLINOIS] FED. AID PROJECT										

**LEGEND**

- ① EXISTING P.C.C. PAVEMENT 10"
- ② EXISTING SUB-BASE GRANULAR MATERIAL, TYPE A 8"
- ③ EXISTING BITUMINOUS SHOULDER 12"±
- ④ EXISTING BITUMINOUS SURFACE COURSE 5 1/4"
- ⑤ EXISTING PIPE UNDERDRAINS
- ⑥ EXISTING AGGREGATE SHOULDERS
- ⑦ EXISTING HIGH TENSION CABLE MEDIAN BARRIER & HOT-MIX ASPHALT SHOULDER, 4" (4' WIDE)
- ⑧ EXISTING BITUMINOUS CONCRETE PAVEMENT (FULL DEPTH), TYPE 1 20 1/2"
- ⑨ EXISTING LIME MODIFIED SOIL, 12"
- ⑩ EXISTING BITUMINOUS SHOULDER 8"
- ⑪ EXISTING BITUMINOUS CONCRETE PAVEMENT (FULL DEPTH), TYPE 1 15 1/2"
- ⑫ EXISTING BITUMINOUS CONCRETE PAVEMENT (FULL DEPTH), TYPE 2 13 1/2"
- ⑬ EXISTING COMBINATION CONCRETE CURB AND GUTTER TYPE M-4.12
- ⑭ EXISTING CONCRETE MEDIAN SURFACE, 4"
- ⑯ PROPOSED HOT-MIX ASPHALT SURFACE REMOVAL, 2 1/4"
- ⑰ PROPOSED POLYMERIZED HOT-MIX ASPHALT BINDER COURSE, IL-19.0, N90 - (2 1/4")
- ⑱ PROPOSED POLYMERIZED HOT-MIX ASPHALT SURFACE COURSE, STONE MATRIX ASPHALT, N80 - (2")
- ⑲ PROPOSED BITUMINOUS MATERIALS (PRIMECOAT)
- ⑳ PROPOSED AGGREGATE (PRIMECOAT)
- ㉑ PROPOSED HOT-MIX ASPHALT SHOULDERS (2")
- ㉒ PROPOSED AGGREGATE SHOULDER, TYPE B
- ㉓ PROPOSED SHOULDER REMOVAL AND REPLACEMENT 12"
- ㉔ PROPOSED PIPE UNDERDRAIN 4"
- ㉕ PROPOSED SHOULDER REMOVAL AND REPLACEMENT 8"
- ㉖ PROPOSED HOT-MIX ASPHALT SURFACE REMOVAL, 1"
- ㉗ PROPOSED LEVELING BINDER (MACHINE METHOD), IL-9.5FG, N90 (1")
- ㉘ NOT USED
- ㉙ PROPOSED HOT-MIX ASPHALT SURFACE REMOVAL, 3"

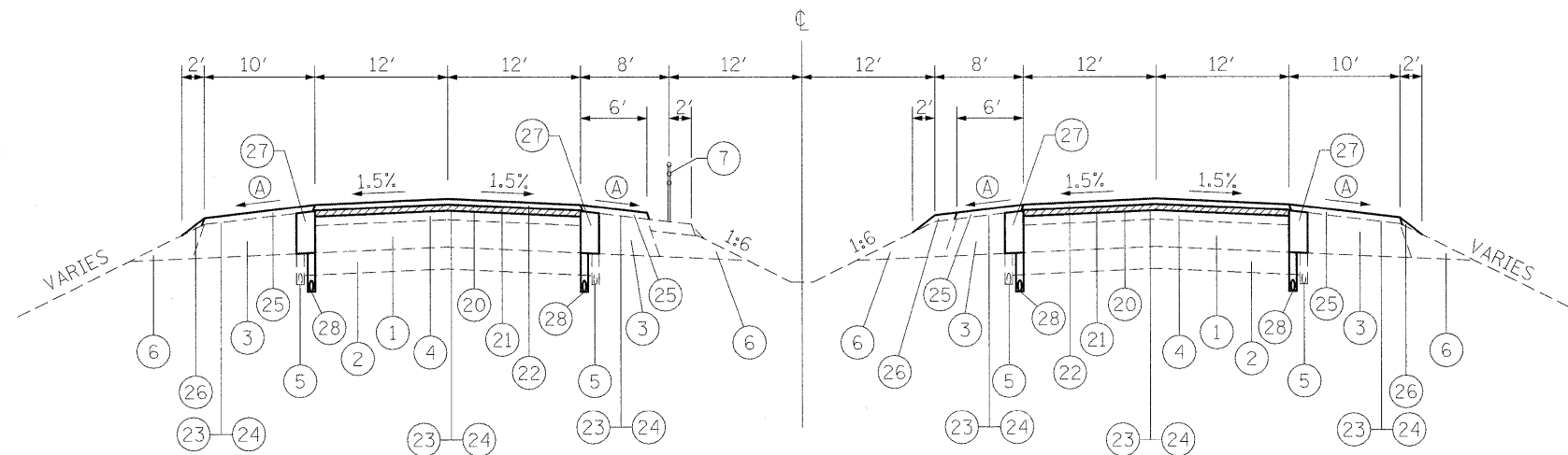

**F.A.I. ROUTE 70 TANGENT**

STA. 587+00 TO STA. 593+01.6  
 STA. 669+75 E.B. TO STA. 704+63 E.B. \* EQUATION STA. 690+77.36 BK = STA. 696+68.33 AH  
 \*\* STA. 669+75 W.B. TO STA. 704+34 W.B. \*  
 STA. 710+13 E.B. TO STA. 714+50 E.B.  
 STA. 711+37 W.B. TO STA. 714+50 W.B.  
 STA. 783+00 TO STA. 792+00  
 (STRUCTURE OVER WILSON HEIGHTS ROAD. STA. 792+96 RESURFACING OMISSION)

\*\* SEE TYPICAL FOR WEIGH IN MOTION SLAB OMISSION

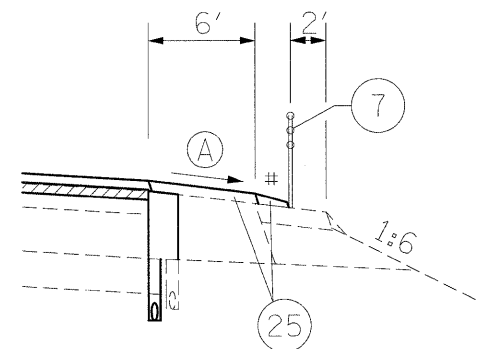

# TAPER FROM 2" TO 3/4" IN 2' SLOPE VARIES

**BITUMINOUS TAPER @ CABLE MEDIAN BARRIER**

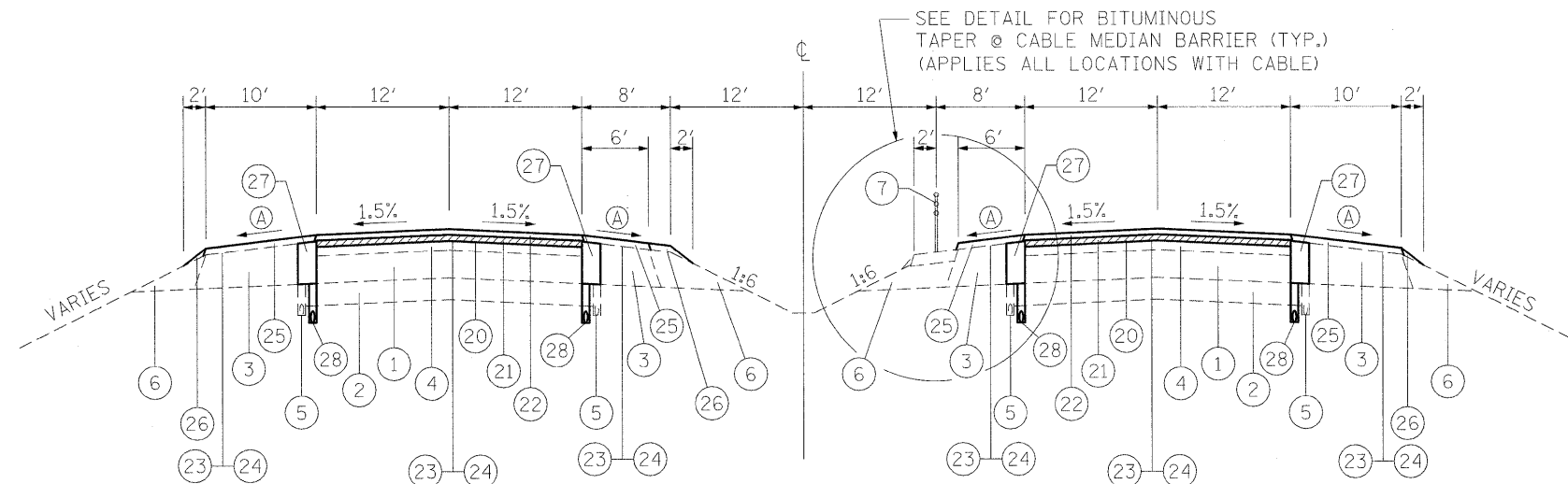

**F.A.I. ROUTE 70 TANGENT**

STA. 564+60 (BEG. OF PROJECT) TO STA. 587+00  
 STA. 626+35.17 E.B. TO STA. 664+95 E.B.  
 STA. 626+35.17 W.B. TO STA. 665+05 W.B.  
 STA. 666+85 E.B. TO STA. 669+75 E.B.  
 STA. 666+95 W.B. TO STA. 669+75 W.B.  
 STA. 714+50. TO STA. 764+95.1  
 STA. 777+95.2 TO STA. 783+00  
 STA. 794+00 TO STA. 806+00

(A) SHOULDER SLOPE RANGE FROM 2% TO 6% DESIRABLE 4%

FILE NAME =	USER NAME = canoverpj	DESIGNED -	REVISED -	<b>STATE OF ILLINOIS DEPARTMENT OF TRANSPORTATION</b>	<b>TYPICAL SECTIONS</b>			F.A.I. RTE.	SECTION	COUNTY	TOTAL SHEETS	SHEET NO.
cd:\pwork\FW1DOT\CONVERPJ\cd0149134\0876A73-ah-typical.dgn		DRAWN -	REVISED -		70	.	MADISON	150	8			
Johnson, Depp & Oulsenberry CONSULTING ENGINEERS Springfield, Illinois	PLOT SCALE = 8,0000 "/> IN.	CHECKED -	REVISED -		CONTRACT NO. 76A73			FED. ROAD DIST. NO.	ILLINOIS	FED. AID PROJECT		
	PLOT DATE = 6/22/2009	DATE -	REVISED -		SCALE:	SHEET NO.	OF SHEETS	STA.	TO STA.			

• 60-(7,8,9,10)RS, 60-(8,9,10)BR



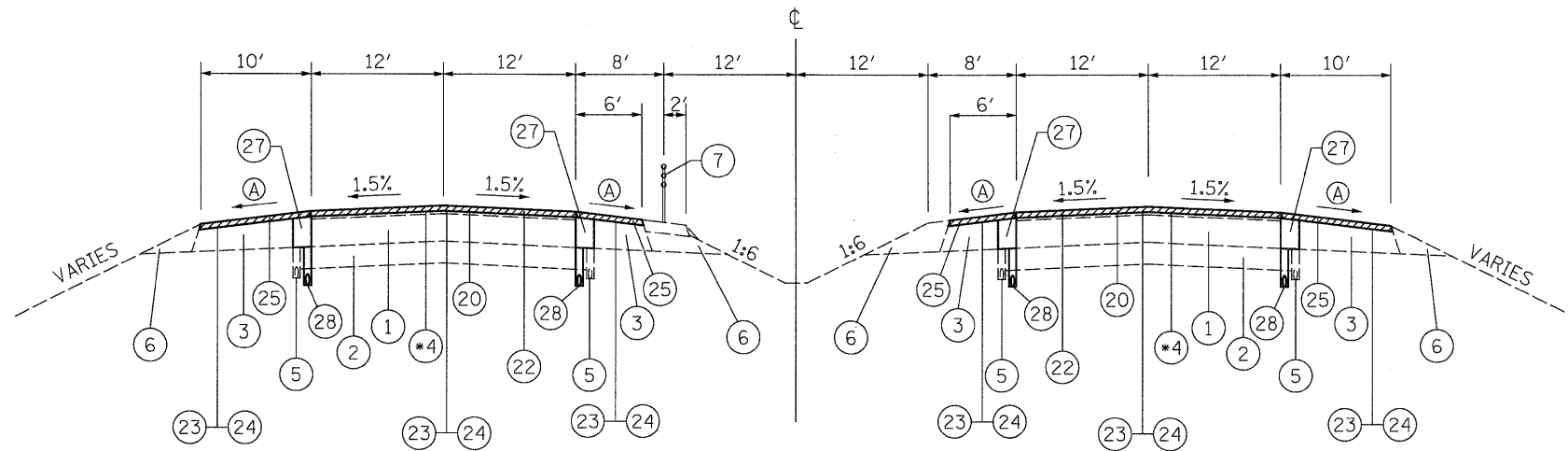

F.A.I. ROUTE 70 TYPICAL SECTION  
UNDER PLEASANT ROAD BRIDGE

STA. 664+95 E.B. TO STA. 666+85 E.B. \* 3"  
STA. 665+05 W.B. TO STA. 666+95 W.B. \* 3"

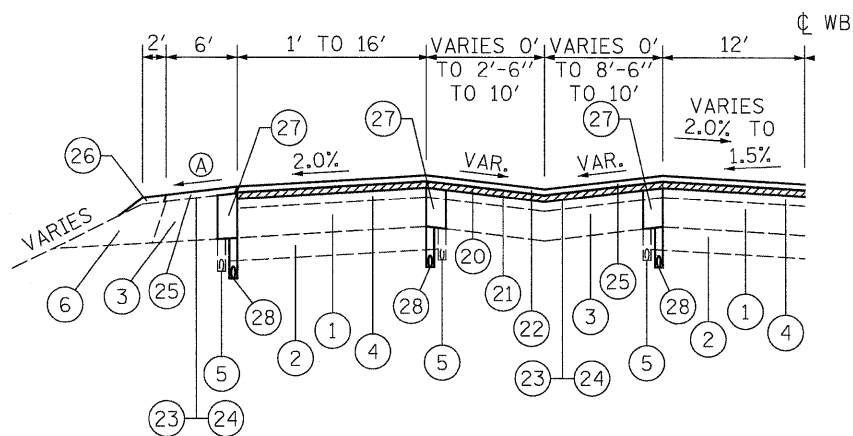

F.A.I. ROUTE 70 TYPICAL SECTION  
WEIGH STATION RAMP

STA. 613+48.92 TO STA. 631+22  
STA. 655+95 TO STA. 663+00

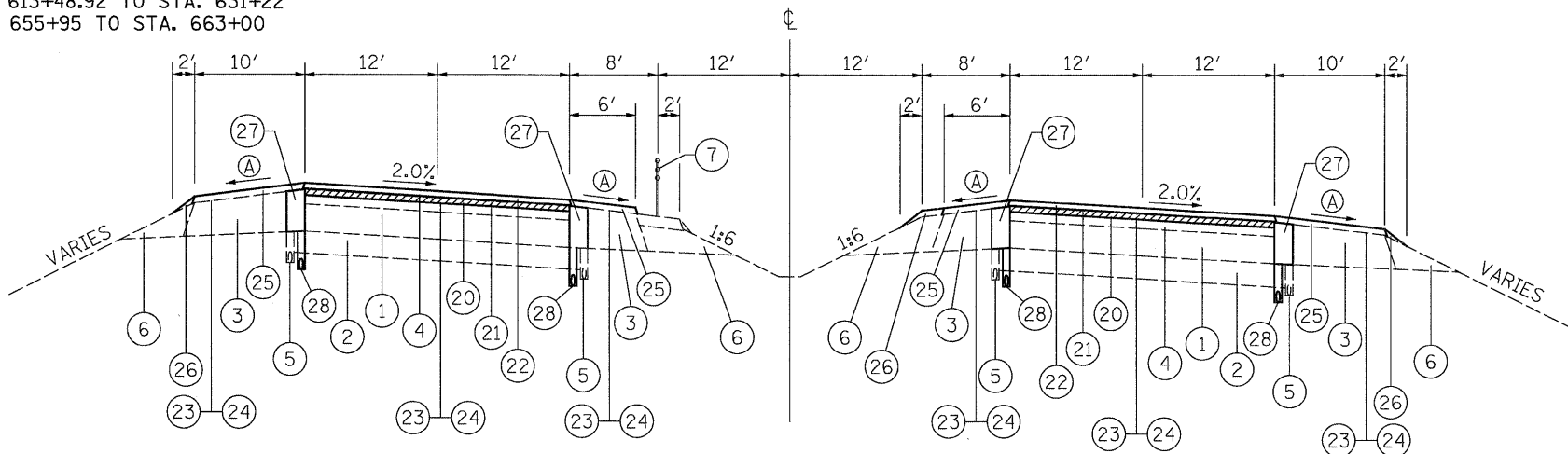

F.A.I. ROUTE 70 TYPICAL SECTION  
SUPERELEVATION

STA. 593+01.6 TO STA. 624+30.93  
(STRUCTURE OVER KEEBLER ROAD STA. 625+31  
RESURFACING OMISSION)

SE TRANSITION  
STA. 592+01.6 N.C. TO STA. 593+01.6 F.S.  
STA. 625+68.3 F.S. TO STA. 626+68.3 N.C.

LEGEND

- ① EXISTING P.C.C. PAVEMENT 10"
- ② EXISTING SUB-BASE GRANULAR MATERIAL, TYPE A 8"
- ③ EXISTING BITUMINOUS SHOULDER 12''±
- ④ EXISTING BITUMINOUS SURFACE COURSE 5 1/4"
- ⑤ EXISTING PIPE UNDERDRAINS
- ⑥ EXISTING AGGREGATE SHOULDERS
- ⑦ EXISTING HIGH TENSION CABLE MEDIAN BARRIER & HOT-MIX ASPHALT SHOULDER, 4" (4' WIDE)
- ⑧ EXISTING BITUMINOUS CONCRETE PAVEMENT (FULL DEPTH), TYPE 1 20 1/2"
- ⑨ EXISTING LIME MODIFIED SOIL, 12"
- ⑩ EXISTING BITUMINOUS SHOULDER 8"
- ⑪ EXISTING BITUMINOUS CONCRETE PAVEMENT (FULL DEPTH), TYPE 1 15 1/2"
- ⑫ EXISTING BITUMINOUS CONCRETE PAVEMENT (FULL DEPTH), TYPE 2 13 1/2"
- ⑬ EXISTING COMBINATION CONCRETE CURB AND GUTTER TYPE M-4.12
- ⑭ EXISTING CONCRETE MEDIAN SURFACE, 4"
- ⑯ PROPOSED HOT-MIX ASPHALT SURFACE REMOVAL, 2 1/4"
- ⑰ PROPOSED POLYMERIZED HOT-MIX ASPHALT BINDER COURSE, IL-19.0, N90 - (2 1/4")
- ⑱ PROPOSED POLYMERIZED HOT-MIX ASPHALT SURFACE COURSE, STONE MATRIX ASPHALT, N80 - (2")
- ⑲ PROPOSED BITUMINOUS MATERIALS (PRIMECOAT)
- ⑳ PROPOSED AGGREGATE (PRIMECOAT)
- ㉑ PROPOSED HOT-MIX ASPHALT SHOULDERS (2")
- ㉒ PROPOSED AGGREGATE SHOULDER, TYPE B
- ㉓ PROPOSED SHOULDER REMOVAL AND REPLACEMENT 12"
- ㉔ PROPOSED PIPE UNDERDRAIN 4"
- ㉕ PROPOSED SHOULDER REMOVAL AND REPLACEMENT 8"
- ㉖ PROPOSED HOT-MIX ASPHALT SURFACE REMOVAL, 1"
- ㉗ PROPOSED LEVELING BINDER (MACHINE METHOD), IL-9.5FG, N90 (1")
- ㉘ NOT USED
- ㉙ PROPOSED HOT-MIX ASPHALT SURFACE REMOVAL, 3"

(A) SHOULDER SLOPE  
RANGE FROM 2% TO 6%  
DESIRABLE 4%



USER NAME = SJS  
PLOT SCALE = 8.0000' / IN.  
PLOT DATE = 05/12/2009 09:16:27

DESIGNED -  
DRAWN -  
CHECKED -  
DATE -

REVISED -  
REVISED -  
REVISED -  
REVISED -

STATE OF ILLINOIS  
DEPARTMENT OF TRANSPORTATION

TYPICAL SECTIONS  
SCALE: SHEET NO. OF SHEETS STA. TO STA.

F.A.I. RTE.	SECTION	COUNTY	TOTAL SHEETS	SHEET NO.
		MADISON	50	9
CONTRACT NO. 76A73				
FED. ROAD DIST. NO. ILLINOIS FED. AID PROJECT				

• 60-(7,8,9,10)RS, 60-(8,9,10)BR

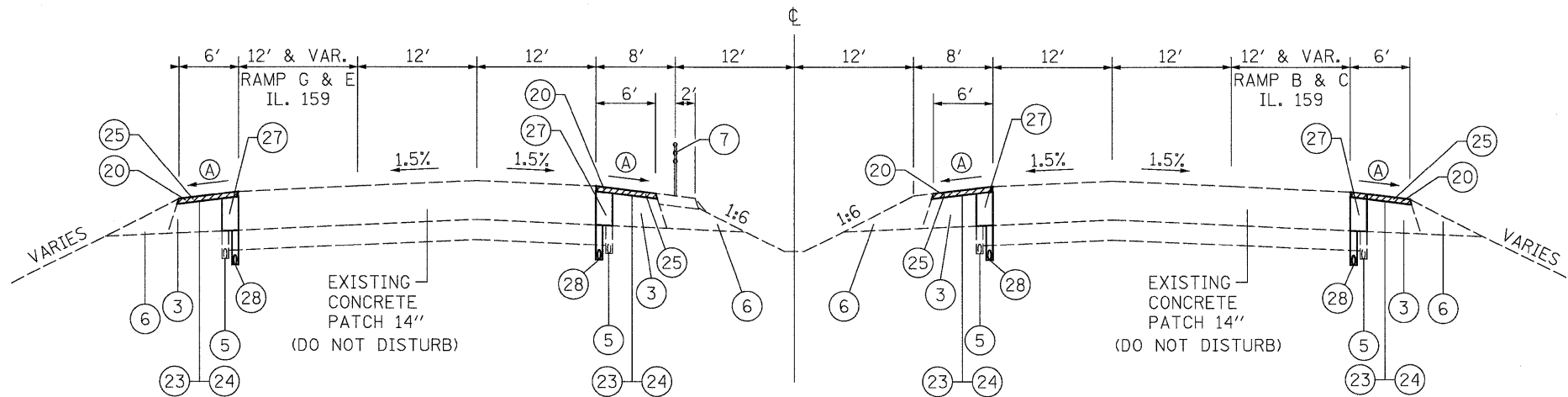

F.A.I. ROUTE 70 TYPICAL SECTION  
UNDER IL. 159 BRIDGE

STA. 704+63 E.B. TO STA. 710+13 E.B.  
STA. 704+34 W.B. TO STA. 711+37 W.B.

NOTE: ITEM 25 INCREASE THICKNESS  
1/4" TO MATCH CONCRETE PATCH

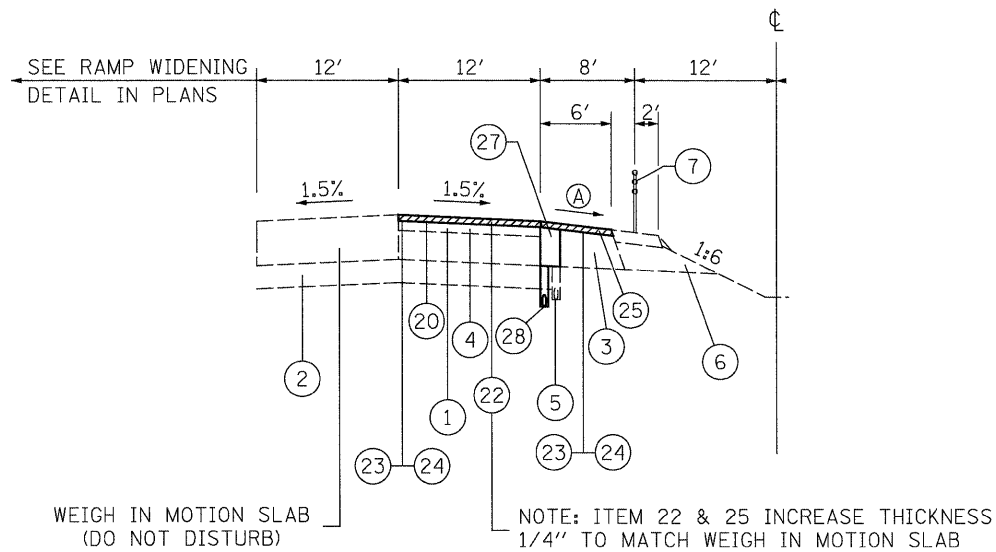

F.A.I. ROUTE 70 TYPICAL SECTION  
(WEIGH IN MOTION SLAB OMISSION)

STA. 686+12 TO STA. 689+12 W.B.

Ⓐ SHOULDER SLOPE  
RANGE FROM 2% TO 6%  
DESIRABLE 4%

LEGEND

- ① EXISTING P.C.C. PAVEMENT 10"
- ② EXISTING SUB-BASE GRANULAR MATERIAL, TYPE A 8"
- ③ EXISTING BITUMINOUS SHOULDER 12"±
- ④ EXISTING BITUMINOUS SURFACE COURSE 5 1/4"
- ⑤ EXISTING PIPE UNDERDRAINS
- ⑥ EXISTING AGGREGATE SHOULDERS
- ⑦ EXISTING HIGH TENSION CABLE MEDIAN BARRIER & HOT-MIX ASPHALT SHOULDER, 4" (4' WIDE)
- ⑧ EXISTING BITUMINOUS CONCRETE PAVEMENT (FULL DEPTH), TYPE 1 20 1/2"
- ⑨ EXISTING LIME MODIFIED SOIL, 12"
- ⑩ EXISTING BITUMINOUS SHOULDER 8"
- ⑪ EXISTING BITUMINOUS CONCRETE PAVEMENT (FULL DEPTH), TYPE 1 15 1/2"
- ⑫ EXISTING BITUMINOUS CONCRETE PAVEMENT (FULL DEPTH), TYPE 2 13 1/2"
- ⑬ EXISTING COMBINATION CONCRETE CURB AND GUTTER TYPE M-4.12
- ⑭ EXISTING CONCRETE MEDIAN SURFACE, 4"
- ⑯ PROPOSED HOT-MIX ASPHALT SURFACE REMOVAL, 2 1/4"
- ⑰ PROPOSED POLYMERIZED HOT-MIX ASPHALT BINDER COURSE, IL-19.0, N90 - (2 1/4")
- ⑱ PROPOSED POLYMERIZED HOT-MIX ASPHALT SURFACE COURSE, STONE MATRIX ASPHALT, N80 - (2")
- ⑲ PROPOSED BITUMINOUS MATERIALS (PRIMECOAT)
- ⑳ PROPOSED AGGREGATE (PRIMECOAT)
- ㉑ PROPOSED HOT-MIX ASPHALT SHOULDERS (2")
- ㉒ PROPOSED AGGREGATE SHOULDER, TYPE B
- ㉓ PROPOSED SHOULDER REMOVAL AND REPLACEMENT 12"
- ㉔ PROPOSED PIPE UNDERDRAIN 4"
- ㉕ PROPOSED SHOULDER REMOVAL AND REPLACEMENT 8"
- ㉖ PROPOSED HOT-MIX ASPHALT SURFACE REMOVAL, 1"
- ㉗ PROPOSED LEVELING BINDER (MACHINE METHOD), IL-9.5FG, N90 (1")
- ㉘ NOT USED
- ㉙ PROPOSED HOT-MIX ASPHALT SURFACE REMOVAL, 3"

• 60-(7,8,9,10)RS, 60-(8,9,10)BR

FILE NAME =	USER NAME = SJS	DESIGNED -	REVISED -	<b>STATE OF ILLINOIS DEPARTMENT OF TRANSPORTATION</b>	<b>TYPICAL SECTIONS</b>			F.A.I. RTE.	SECTION	COUNTY	TOTAL SHEETS	SHEET NO.
... \0876A73-sht-typical.dgn		DRAWN -	REVISED -		70		MADISON	150	10			
Johnson, Depp & Gulsenberry CONSULTING ENGINEERS Springfield, Illinois	PLOT SCALE = 8.0000' / IN.	CHECKED -	REVISED -		CONTRACT NO. 76A73							
	PLOT DATE = 06/12/2009 09:16:29	DATE -	REVISED -		SCALE:	SHEET NO.	OF SHEETS	STA.	TO STA.	FED. ROAD DIST. NO.	ILLINOIS FED. AID PROJECT	

(A) SHOULDER SLOPE  
RANGE FROM 2% TO 6%  
DESIRABLE 4%

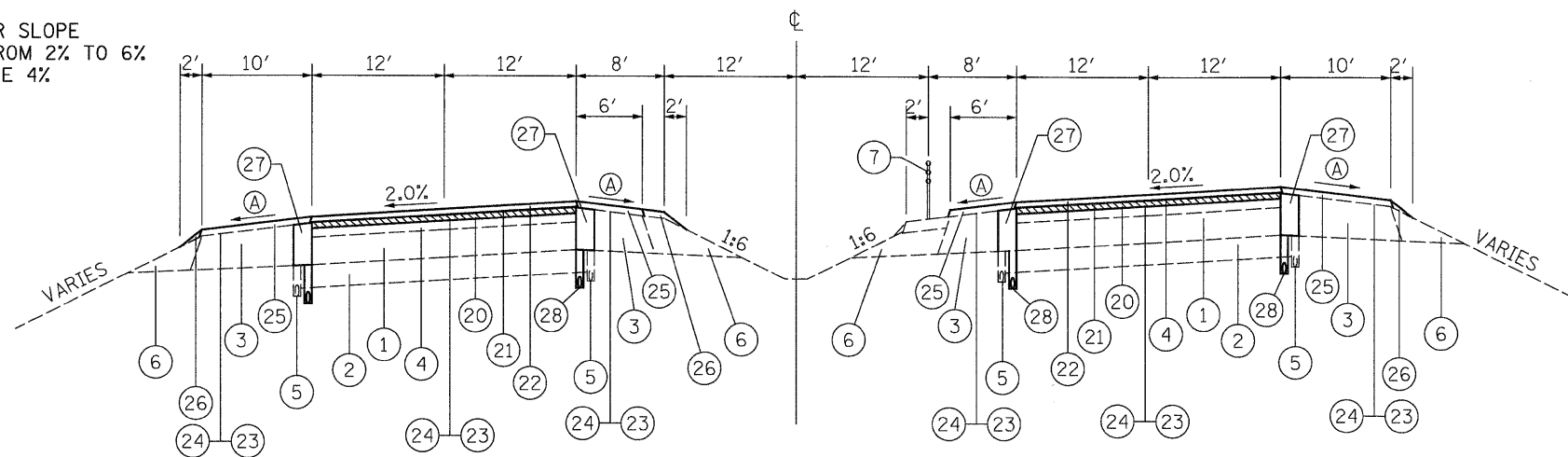

F.A.I. ROUTE 70 TYPICAL SECTION  
SUPERELEVATION (A)

STA. 764+95.1 TO STA. 777+95.2

(A) SE TRANSITION  
STA. 762+95.1 N.C. TO STA. 764+95.1 F.S.  
STA. 777+95.2 F.S. TO STA. 778+95.2 N.C.

LEGEND

- (1) EXISTING P.C.C. PAVEMENT 10"
- (2) EXISTING SUB-BASE GRANULAR MATERIAL, TYPE A 8"
- (3) EXISTING BITUMINOUS SHOULDER 12"±
- (4) EXISTING BITUMINOUS SURFACE COURSE 5 1/4"
- (5) EXISTING PIPE UNDERDRAINS
- (6) EXISTING AGGREGATE SHOULDERS
- (7) EXISTING HIGH TENSION CABLE MEDIAN BARRIER & HOT-MIX ASPHALT SHOULDER, 4" (4' WIDE)
- (8) EXISTING BITUMINOUS CONCRETE PAVEMENT (FULL DEPTH), TYPE 1 20 1/2"
- (9) EXISTING LIME MODIFIED SOIL, 12"
- (10) EXISTING BITUMINOUS SHOULDER 8"
- (11) EXISTING BITUMINOUS CONCRETE PAVEMENT (FULL DEPTH), TYPE 1 15 1/2"
- (12) EXISTING BITUMINOUS CONCRETE PAVEMENT (FULL DEPTH), TYPE 2 13 1/2"
- (13) EXISTING COMBINATION CONCRETE CURB AND GUTTER TYPE M-4.12
- (14) EXISTING CONCRETE MEDIAN SURFACE, 4"
- (20) PROPOSED HOT-MIX ASPHALT SURFACE REMOVAL, 2 1/4"
- (21) PROPOSED POLYMERIZED HOT-MIX ASPHALT BINDER COURSE, IL-19.0, N90 - (2 1/4")
- (22) PROPOSED POLYMERIZED HOT-MIX ASPHALT SURFACE COURSE, STONE MATRIX ASPHALT, N80 - (2")
- (23) PROPOSED BITUMINOUS MATERIALS (PRIMECOAT)
- (24) PROPOSED AGGREGATE (PRIMECOAT)
- (25) PROPOSED HOT-MIX ASPHALT SHOULDERS (2")
- (26) PROPOSED AGGREGATE SHOULDER, TYPE B
- (27) PROPOSED SHOULDER REMOVAL AND REPLACEMENT 12"
- (28) PROPOSED PIPE UNDERDRAIN 4"
- (29) PROPOSED SHOULDER REMOVAL AND REPLACEMENT 8"
- (30) PROPOSED HOT-MIX ASPHALT SURFACE REMOVAL, 1"
- (31) PROPOSED LEVELING BINDER (MACHINE METHOD), IL-9.5FG, N90 (1")
- (32) NOT USED
- (33) PROPOSED HOT-MIX ASPHALT SURFACE REMOVAL, 3"

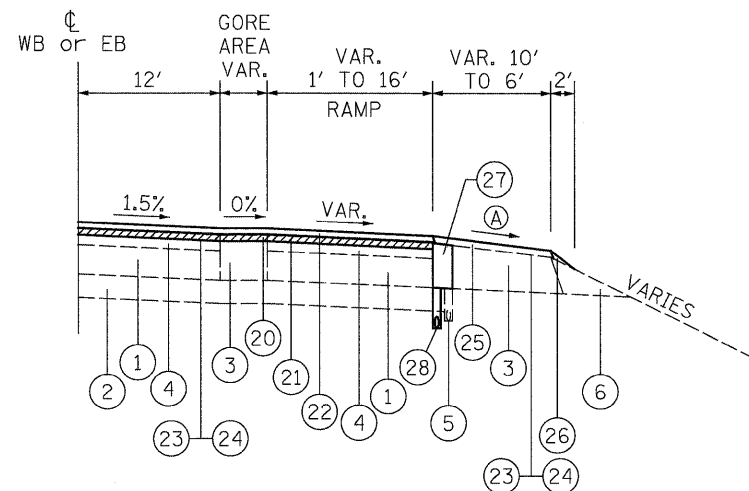

RAMP TERMINAL TYPICAL SECTION  
(IL 159 INTERCHANGE)

RAMP A, D, F, & H

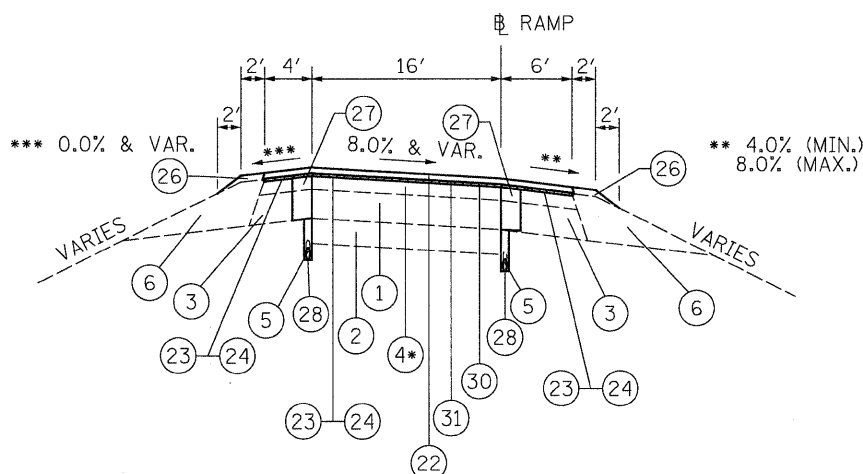

RAMP TYPICAL SECTION  
(IL 159 INTERCHANGE)

RAMP A & H (3 1/4")\*  
RAMP D & F (5 1/4")\*  
RAMP B, C, E & G (3 1/4")\*±

RAMP STAGING

CONSTRUCTION OPERATIONS SHALL BE CONFINED TO AN AREA NARROW ENOUGH THAT A MINIMUM OF 10' OF PAVEMENT SHALL BE OPEN TO TRAFFIC AT ALL TIMES.

FULL WIDTH PAVEMENT ON THE RAMPS SHALL BE OPEN TO TRAFFIC AT NIGHT.

SIGNS, BARRICADES, AND FLAGGER SHALL BE AS DETAILED IN STANDARD 701456. WHEN NO WORK IS BEING PERFORMED, THE FLAGGER WILL NOT BE REQUIRED. IF THE FLAGGER IS NOT PRESENT, THE FLAGGER SIGNS SHALL BE REMOVED OR COVERED.

LONGITUDINAL DIMENSIONS AS SHOWN ON STANDARD 701456, MAY BE ADJUSTED TO FIT FIELD CONDITIONS.

ALL VEHICLES, EQUIPMENT, WORKERS (EXCEPT FLAGGER) AND THEIR ACTIVITIES ARE RESTRICTED AT ALL TIMES TO ONE SIDE OF THE PAVEMENT UNLESS OTHERWISE AUTHORIZED BY THE ENGINEER.

• 60-(7,8,9,10)RS, 60-(8,9,10)BR

FILE NAME = ...0876A73-shr-typ1ce1.dgn	USER NAME = SJS	DESIGNED -	REVISED -	<b>STATE OF ILLINOIS DEPARTMENT OF TRANSPORTATION</b>	<b>TYPICAL SECTIONS</b>			F.A.I. RTE. 70	SECTION *	COUNTY MADISON	TOTAL SHEETS 150	SHEET NO. 11
Johnson, Depp & Quisenberry CONSULTING ENGINEERS Springfield, Illinois	PLOT SCALE = 8.0000' / IN.	DRAWN -	REVISED -					SCALE:	SHEET NO. OF SHEETS	STA. TO STA.	CONTRACT NO. 76A73	
	PLOT DATE = 05/12/2009 09:16:31	CHECKED -	REVISED -				FED. ROAD DIST. NO. ILLINOIS FED. AID PROJECT					
		DATE -	REVISED -									

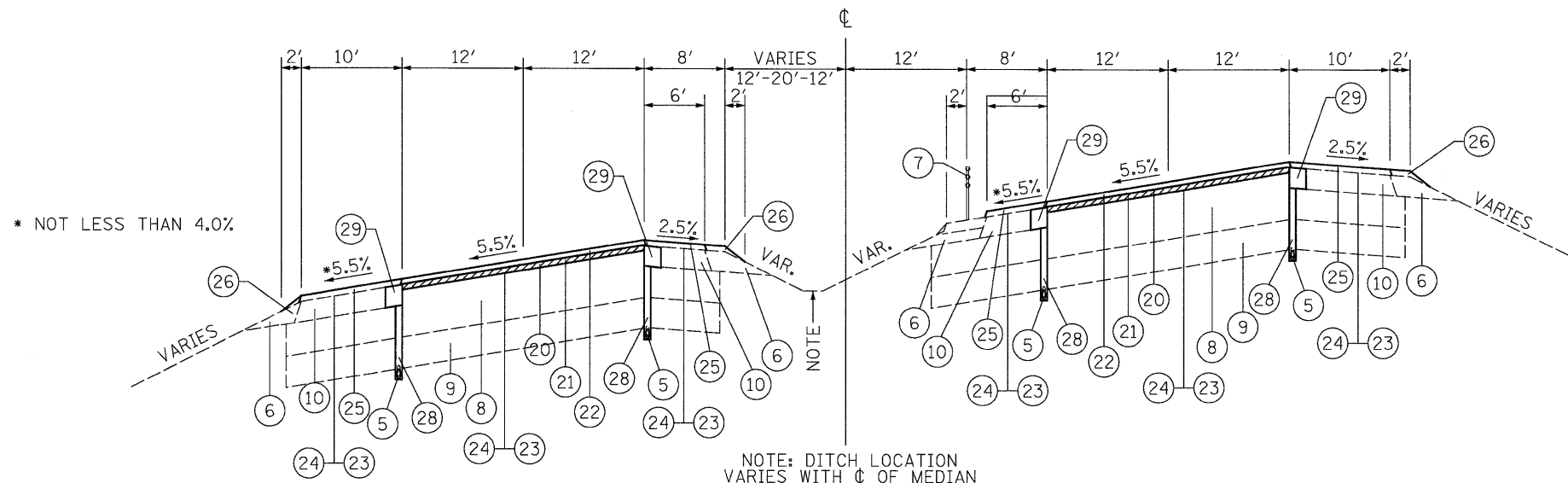

**F.A.I. ROUTE 70 TYPICAL SECTION  
SUPERELEVATION (A)**

STA. 821+48.55 N.B. TO STA. 846+75.51 N.B.  
STA. 822+51.91 S.B. TO STA. 845+22.78 S.B.

MEDIAN WIDTH VARIES:  
STA. 816+10.70 TO STA. 821+51.71 - 40' TO 48'  
STA. 821+51.71 TO STA. 846+72.35 - 48'  
STA. 846+72.35 TO STA. 852+13.37 - 48' TO 40'

(A) MAX. SHOULDER BREAKOVER 8%  
SE TRANSITION  
N.B. LANES  
STA. 818+42.55 N.C. TO STA. 821+48.55 F.S.  
STA. 846+75.51 F.S. TO STA. 849+81.51 N.C.  
S.B. LANES  
STA. 819+45.91 N.C. TO STA. 822+51.91 F.S.  
STA. 845+22.78 F.S. TO STA. 848+28.78 N.C.

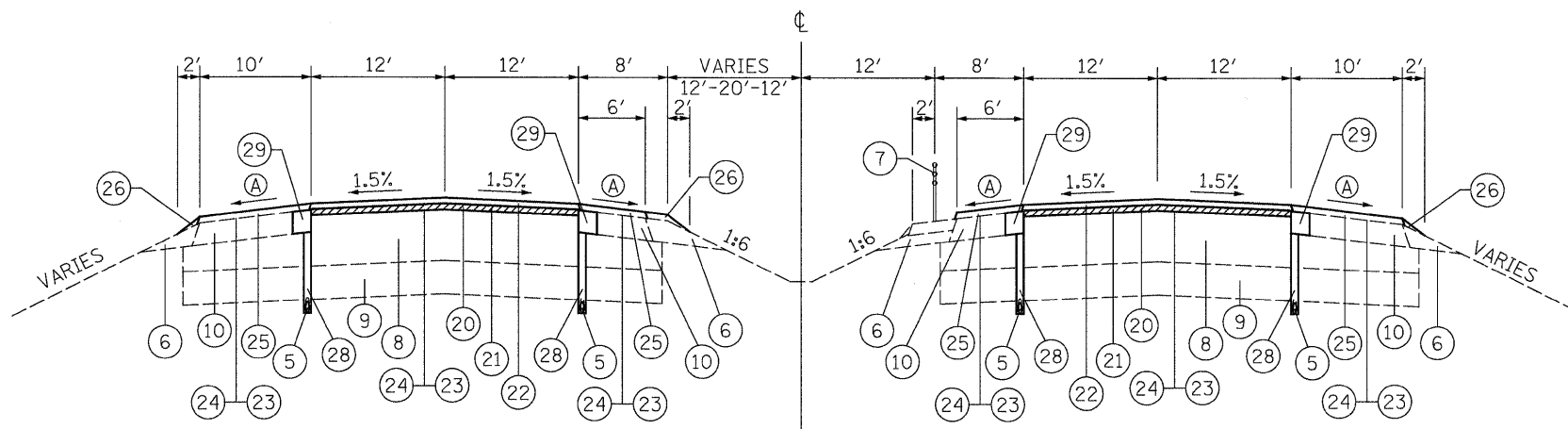

**F.A.I. ROUTE 70 TYPICAL SECTION  
TANGENT**

STA. 806+00 N.B. TO STA. 821+48.55 N.B.  
STA. 806+00 S.B. TO STA. 822+51.91 S.B.  
STA. 846+75.51 N.B. TO STA. 856+00 N.B. \*\*  
STA. 845+22.78 S.B. TO STA. 856+00 S.B. \*\*

\*\* EQUATION STA. 856+00 BK =  
STA. 1382+94 AH

NOTE: STATIONS RUN NORTH TO SOUTH  
STARTING AT STA. 1382+94

**LEGEND**

- ① EXISTING P.C.C. PAVEMENT 10"
- ② EXISTING SUB-BASE GRANULAR MATERIAL, TYPE A 8"
- ③ EXISTING BITUMINOUS SHOULDER 12"±
- ④ EXISTING BITUMINOUS SURFACE COURSE 5 1/4"
- ⑤ EXISTING PIPE UNDERDRAINS
- ⑥ EXISTING AGGREGATE SHOULDERS
- ⑦ EXISTING HIGH TENSION CABLE MEDIAN BARRIER & HOT-MIX ASPHALT SHOULDER, 4" (4' WIDE)
- ⑧ EXISTING BITUMINOUS CONCRETE PAVEMENT (FULL DEPTH), TYPE 1 20 1/2"
- ⑨ EXISTING LIME MODIFIED SOIL, 12"
- ⑩ EXISTING BITUMINOUS SHOULDER 8"
- ⑪ EXISTING BITUMINOUS CONCRETE PAVEMENT (FULL DEPTH), TYPE 1 15 1/2"
- ⑫ EXISTING BITUMINOUS CONCRETE PAVEMENT (FULL DEPTH), TYPE 2 13 1/2"
- ⑬ EXISTING COMBINATION CONCRETE CURB AND GUTTER TYPE M-4.12
- ⑭ EXISTING CONCRETE MEDIAN SURFACE, 4"
- ⑮ PROPOSED HOT-MIX ASPHALT SURFACE REMOVAL, 2 1/4"
- ⑯ PROPOSED POLYMERIZED HOT-MIX ASPHALT BINDER COURSE, IL-19.0, N90 - (2 1/4")
- ⑰ PROPOSED POLYMERIZED HOT-MIX ASPHALT SURFACE COURSE, STONE MATRIX ASPHALT, N80 - (2")
- ⑱ PROPOSED BITUMINOUS MATERIALS (PRIMECOAT)
- ⑲ PROPOSED AGGREGATE (PRIMECOAT)
- ⑳ PROPOSED HOT-MIX ASPHALT SHOULDERS (2")
- ㉑ PROPOSED AGGREGATE SHOULDER, TYPE B
- ㉒ PROPOSED SHOULDER REMOVAL AND REPLACEMENT 12"
- ㉓ PROPOSED PIPE UNDERDRAIN 4"
- ㉔ PROPOSED SHOULDER REMOVAL AND REPLACEMENT 8"
- ㉕ PROPOSED HOT-MIX ASPHALT SURFACE REMOVAL, 1"
- ㉖ PROPOSED LEVELING BINDER (MACHINE METHOD), IL-9.5FG, N90 (1")
- ㉗ NOT USED
- ㉘ PROPOSED HOT-MIX ASPHALT SURFACE REMOVAL, 3"

(A) SHOULDER SLOPE  
RANGE FROM 2% TO 6%  
DESIRABLE 4%

FILE NAME =	USER NAME = SJS	DESIGNED -	REVISED -	<b>STATE OF ILLINOIS DEPARTMENT OF TRANSPORTATION</b>	<b>TYPICAL SECTIONS</b>			F.A.I. RTE.	SECTION	COUNTY	TOTAL SHEETS	SHEET NO.
... \D876A73-sh-typical.dgn	PLOT SCALE = 8.0000' / IN.	DRAWN -	REVISED -					70	.	MADISON	150	12
Johnson, Depp & Oulsenberry CONSULTING ENGINEERS Springfield, Illinois	PLOT DATE = 05/12/2009 09:16:34	CHECKED -	REVISED -		SCALE: SHEET NO. OF SHEETS STA. TO STA.			CONTRACT NO. 76A73				
		DATE -	REVISED -					ILLINOIS FED. AID PROJECT				

\* 60-(7,8,9,10)RS, 60-(8,9,10)BR

**LEGEND**

- ① EXISTING P.C.C. PAVEMENT 10"
- ② EXISTING SUB-BASE GRANULAR MATERIAL, TYPE A 8"
- ③ EXISTING BITUMINOUS SHOULDER 12"±
- ④ EXISTING BITUMINOUS SURFACE COURSE 5 1/4"
- ⑤ EXISTING PIPE UNDERDRAINS
- ⑥ EXISTING AGGREGATE SHOULDERS
- ⑦ EXISTING HIGH TENSION CABLE MEDIAN BARRIER & HOT-MIX ASPHALT SHOULDER, 4" (4' WIDE)
- ⑧ EXISTING BITUMINOUS CONCRETE PAVEMENT (FULL DEPTH), TYPE 1 20 1/2"
- ⑨ EXISTING LIME MODIFIED SOIL, 12"
- ⑩ EXISTING BITUMINOUS SHOULDER 8"
- ⑪ EXISTING BITUMINOUS CONCRETE PAVEMENT (FULL DEPTH), TYPE 1 15 1/2"
- ⑫ EXISTING BITUMINOUS CONCRETE PAVEMENT (FULL DEPTH), TYPE 2 13 1/2"
- ⑬ EXISTING COMBINATION CONCRETE CURB AND GUTTER TYPE M-4.12
- ⑭ EXISTING CONCRETE MEDIAN SURFACE, 4"
- ⑮ PROPOSED HOT-MIX ASPHALT SURFACE REMOVAL, 2 1/4"
- ⑯ PROPOSED POLYMERIZED HOT-MIX ASPHALT BINDER COURSE, IL-19.0, N90 - (2 1/4")
- ⑰ PROPOSED POLYMERIZED HOT-MIX ASPHALT SURFACE COURSE, STONE MATRIX ASPHALT, N80 - (2")
- ⑱ PROPOSED BITUMINOUS MATERIALS (PRIMECOAT)
- ⑲ PROPOSED AGGREGATE (PRIMECOAT)
- ⑳ PROPOSED HOT-MIX ASPHALT SHOULDERS (2")
- ㉑ PROPOSED AGGREGATE SHOULDER, TYPE B
- ㉒ PROPOSED SHOULDER REMOVAL AND REPLACEMENT 12"
- ㉓ PROPOSED PIPE UNDERDRAIN 4"
- ㉔ PROPOSED SHOULDER REMOVAL AND REPLACEMENT 8"
- ㉕ PROPOSED HOT-MIX ASPHALT SURFACE REMOVAL, 1"
- ㉖ PROPOSED LEVELING BINDER (MACHINE METHOD), IL-9.5FG, N90 (1")
- ㉗ NOT USED
- ㉘ PROPOSED HOT-MIX ASPHALT SURFACE REMOVAL, 3"

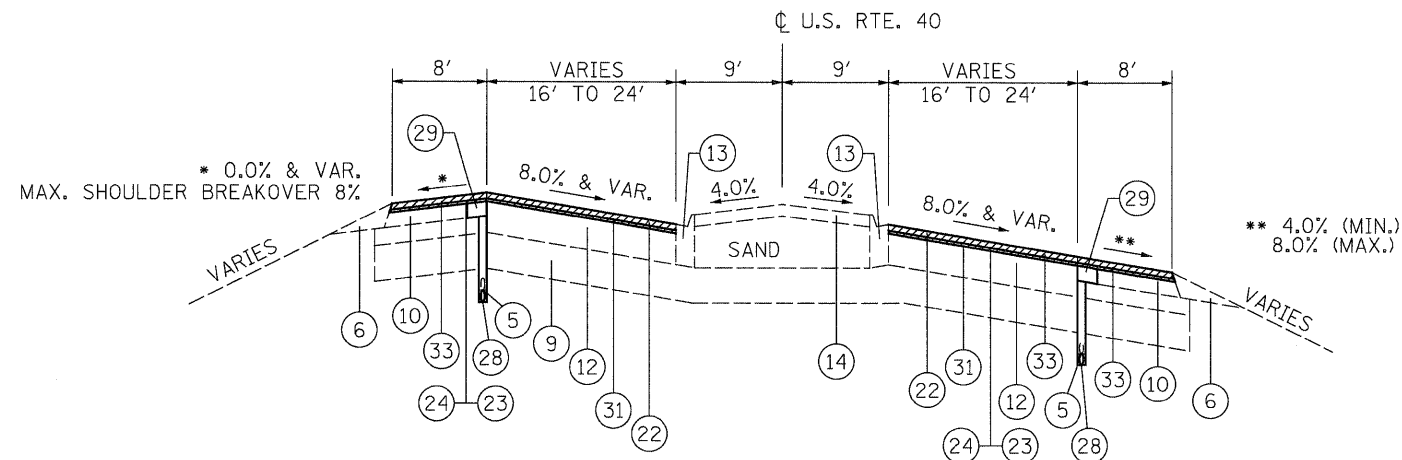

**U.S. RTE. 40 TYPICAL SECTION  
(U.S. ROUTE 40 INTERCHANGE)**

STA. 132+87.25 TO STA. 144+35.89 END OF WEST BRIDGE APPROACH PAVEMENT  
STA. 147+10.14 END OF EAST BRIDGE APPROACH PAVEMENT TO STA. 160+59.95 (END RESURFACING)

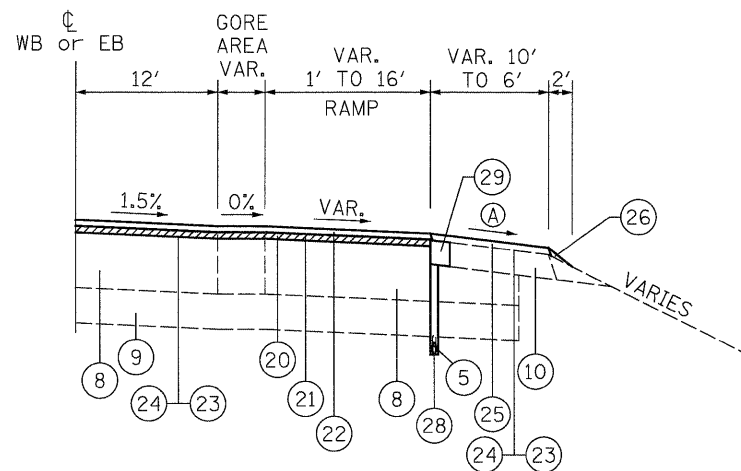

**RAMP TERMINAL TYPICAL SECTION  
(U.S. ROUTE 40 INTERCHANGE)**

RAMP 1, 2, 3, & 4

Ⓐ SHOULDER SLOPE  
RANGE FROM 2% TO 6%  
DESIRABLE 4%

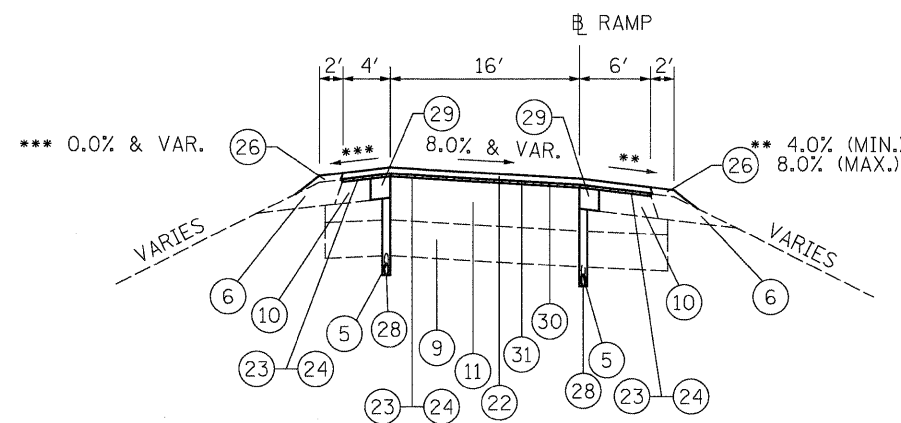

**RAMP TYPICAL SECTION  
(U.S. ROUTE 40 INTERCHANGE)**

RAMP 1, 2, 3, & 4

**RAMP STAGING**

CONSTRUCTION OPERATIONS SHALL BE CONFINED TO AN AREA NARROW ENOUGH THAT A MINIMUM OF 10' OF PAVEMENT SHALL BE OPEN TO TRAFFIC AT ALL TIMES.

FULL WIDTH PAVEMENT ON THE RAMPS SHALL BE OPEN TO TRAFFIC AT NIGHT.

SIGNS, BARRICADES, AND FLAGGER SHALL BE AS DETAILED IN STANDARD 701456. WHEN NO WORK IS BEING PERFORMED, THE FLAGGER WILL NOT BE REQUIRED. IF THE FLAGGER IS NOT PRESENT, THE FLAGGER SIGNS SHALL BE REMOVED OR COVERED.

LONGITUDINAL DIMENSIONS AS SHOWN ON STANDARD 701456, MAY BE ADJUSTED TO FIT FIELD CONDITIONS.

ALL VEHICLES, EQUIPMENT, WORKERS (EXCEPT FLAGGER) AND THEIR ACTIVITIES ARE RESTRICTED AT ALL TIMES TO ONE SIDE OF THE PAVEMENT UNLESS OTHERWISE AUTHORIZED BY THE ENGINEER.

• 60-(7,8,9,10)RS, 60-(8,9,10)BR

FILE NAME = ... \0876A73-eh-typical.dgn Johnson, Depp & Quisenberry CONSULTING ENGINEERS Springfield, Illinois	USER NAME = SJS	DESIGNED -	REVISED -	<b>STATE OF ILLINOIS DEPARTMENT OF TRANSPORTATION</b>	<b>TYPICAL SECTIONS</b>				F.A.I. RTE. 70	SECTION *	COUNTY MADISON	TOTAL SHEETS 150	SHEET NO. 13
	PLOT SCALE = 8.0000' / IN. PLOT DATE = 06/12/2009 09:16:37	CHECKED - DATE -	DRAWN - REVISED - REVISED - REVISED -		SCALE: SHEET NO. OF SHEETS STA. TO STA.	CONTRACT NO. 76A73				ILLINOIS FED. AID PROJECT			

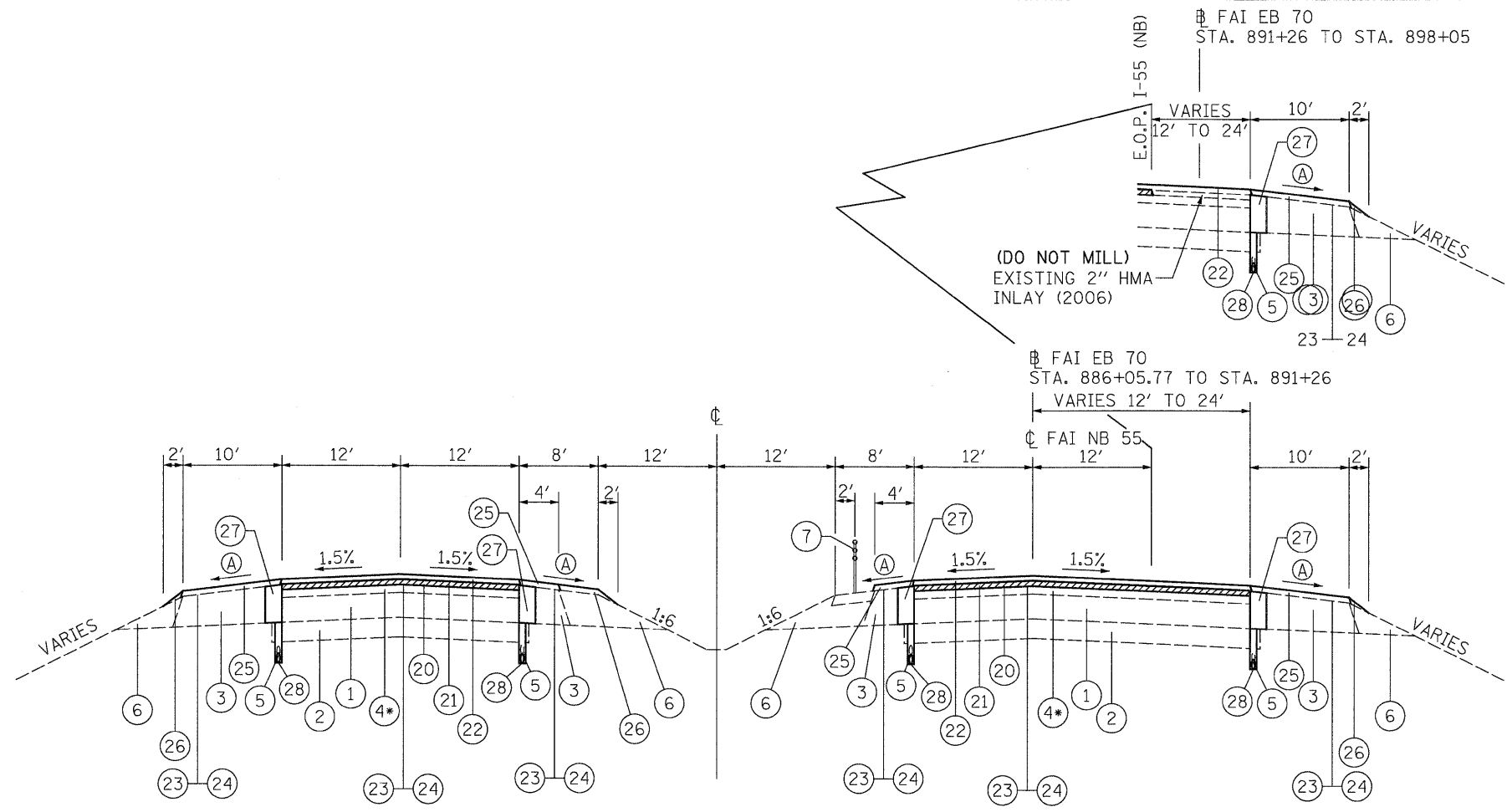

F.A.I. ROUTE 70 TANGENT

STA. 1332+05 TO STA. 1310+00 \* 4 3/4"

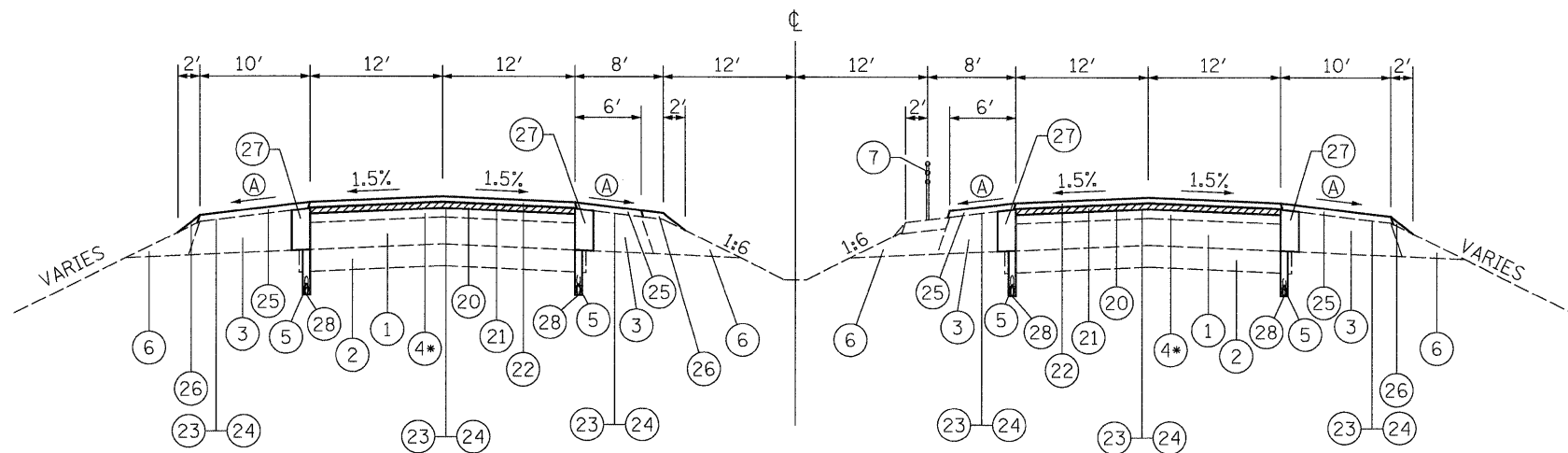

F.A.I. ROUTE 70 TANGENT

STA. 1382+94 TO STA. 1332+05 \* 4 3/4"  
 RESURFACING OMISSION  
 STA. 1355+36 TO STA. 1351+27 SB LANES  
 STA. 1355+20 TO STA. 1351+00 NB LANES

(A) SHOULDER SLOPE  
 RANGE FROM 2% TO 6%  
 DESIRABLE 4%

LEGEND

- ① EXISTING P.C.C. PAVEMENT 10"
- ② EXISTING SUB-BASE GRANULAR MATERIAL, TYPE A 8"
- ③ EXISTING BITUMINOUS SHOULDER 12"±
- ④ EXISTING BITUMINOUS SURFACE COURSE 5 1/4"
- ⑤ EXISTING PIPE UNDERDRAINS
- ⑥ EXISTING AGGREGATE SHOULDERS
- ⑦ EXISTING HIGH TENSION CABLE MEDIAN BARRIER & HOT-MIX ASPHALT SHOULDER, 4" (4' WIDE)
- ⑧ EXISTING BITUMINOUS CONCRETE PAVEMENT (FULL DEPTH), TYPE 1 20 1/2"
- ⑨ EXISTING LIME MODIFIED SOIL, 12"
- ⑩ EXISTING BITUMINOUS SHOULDER 8"
- ⑪ EXISTING BITUMINOUS CONCRETE PAVEMENT (FULL DEPTH), TYPE 1 15 1/2"
- ⑫ EXISTING BITUMINOUS CONCRETE PAVEMENT (FULL DEPTH), TYPE 2 13 1/2"
- ⑬ EXISTING COMBINATION CONCRETE CURB AND GUTTER TYPE M-4.12
- ⑭ EXISTING CONCRETE MEDIAN SURFACE, 4"
- ⑯ PROPOSED HOT-MIX ASPHALT SURFACE REMOVAL, 2 1/4"
- ⑰ PROPOSED POLYMERIZED HOT-MIX ASPHALT BINDER COURSE, IL-19.0, N90 - (2 1/4")
- ⑱ PROPOSED POLYMERIZED HOT-MIX ASPHALT SURFACE COURSE, STONE MATRIX ASPHALT, N80 - (2")
- ⑲ PROPOSED BITUMINOUS MATERIALS (PRIMECOAT)
- ⑳ PROPOSED AGGREGATE (PRIMECOAT)
- ㉑ PROPOSED HOT-MIX ASPHALT SHOULDERS (2")
- ㉒ PROPOSED AGGREGATE SHOULDER, TYPE B
- ㉓ PROPOSED SHOULDER REMOVAL AND REPLACEMENT 12"
- ㉔ PROPOSED PIPE UNDERDRAIN 4"
- ㉕ PROPOSED SHOULDER REMOVAL AND REPLACEMENT 8"
- ㉖ PROPOSED HOT-MIX ASPHALT SURFACE REMOVAL, 1"
- ㉗ PROPOSED LEVELING BINDER (MACHINE METHOD), IL-9.5FG, N90 (1")
- ㉘ NOT USED
- ㉙ PROPOSED HOT-MIX ASPHALT SURFACE REMOVAL, 3"

FILE NAME =	USER NAME = SJS	DESIGNED -	REVISED -	<b>STATE OF ILLINOIS DEPARTMENT OF TRANSPORTATION</b>	<b>TYPICAL SECTIONS</b>			F.A.I. RTE.	SECTION	COUNTY	TOTAL SHEETS	SHEET NO.
... \0876A73-sh-t-typ1001.dgn	PLOT SCALE = 8.0000' / IN.	DRAWN -	REVISED -					TO		MADISON	150	14
	PLOT DATE = 06/12/2009 09:16:39	CHECKED -	REVISED -		SCALE:	SHEET NO.	OF SHEETS	STA.	TO STA.	FED. ROAD DIST. NO.	ILLINOIS FED. AID PROJECT	CONTRACT NO. 76A73
		DATE -	REVISED -									



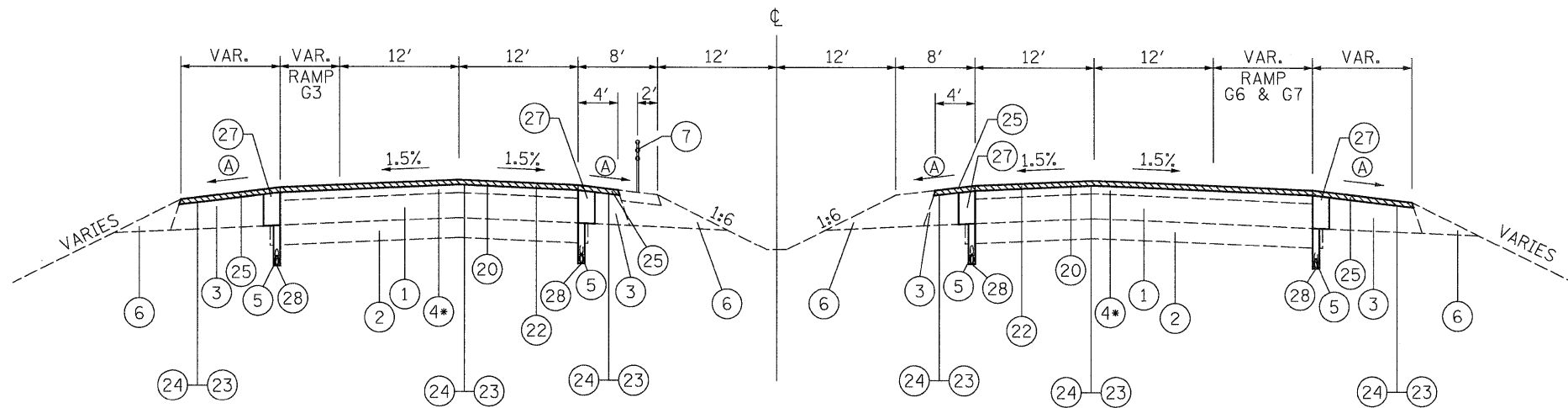

F.A.I. ROUTE 70 TYPICAL SECTION  
UNDER TWIN I-270 BRIDGES

STA. 1281+00 TO STA. 1277+00 \* 4 3/4"

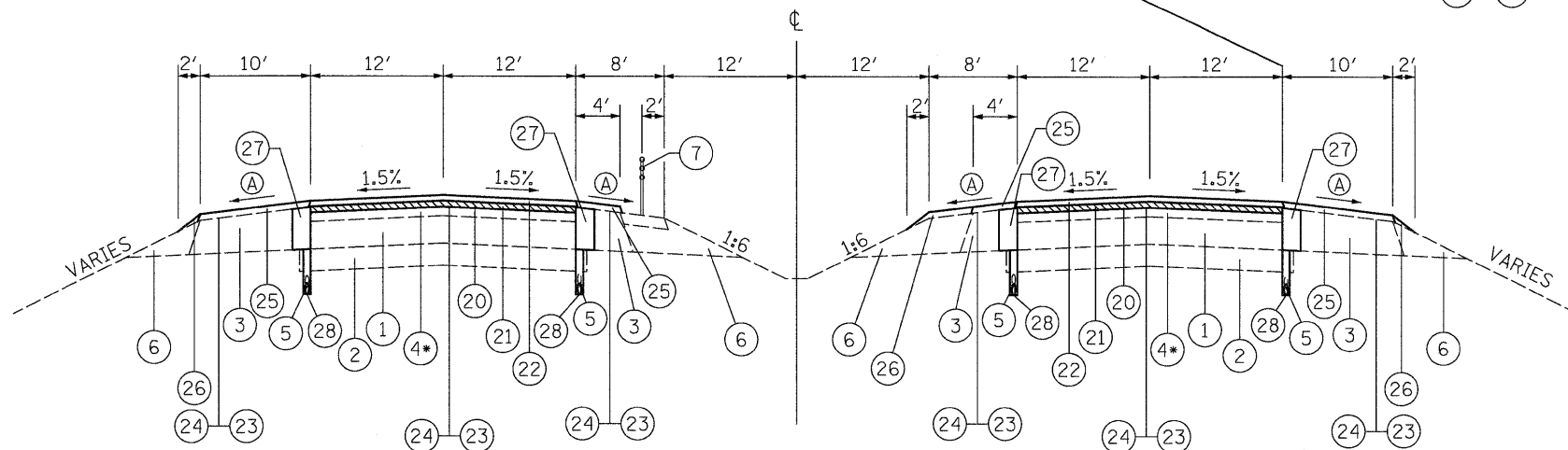
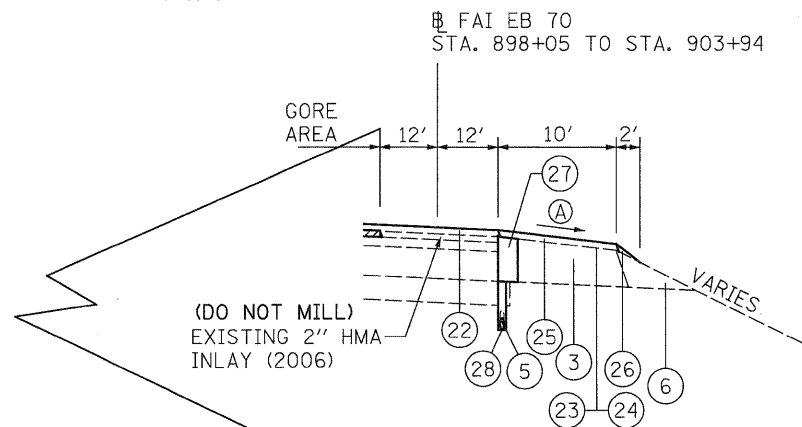

F.A.I. ROUTE 70 TYPICAL SECTION  
TANGENT

STA. 1310+00 TO STA. 1281+00 \* 4 3/4"  
STA. 1277+00 TO STA. 1263+58 (END OF PROJECT) \* 4 3/4"

(A) SHOULDER SLOPE  
RANGE FROM 2% TO 6%  
DESIRABLE 4%

LEGEND

- 1 EXISTING P.C.C. PAVEMENT 10"
- 2 EXISTING SUB-BASE GRANULAR MATERIAL, TYPE A 8"
- 3 EXISTING BITUMINOUS SHOULDER 12"±
- 4 EXISTING BITUMINOUS SURFACE COURSE 5 1/4"
- 5 EXISTING PIPE UNDERDRAINS
- 6 EXISTING AGGREGATE SHOULDERS
- 7 EXISTING HIGH TENSION CABLE MEDIAN BARRIER & HOT-MIX ASPHALT SHOULDER, 4" (4' WIDE)
- 8 EXISTING BITUMINOUS CONCRETE PAVEMENT (FULL DEPTH), TYPE 1 20 1/2"
- 9 EXISTING LIME MODIFIED SOIL, 12"
- 10 EXISTING BITUMINOUS SHOULDER 8"
- 11 EXISTING BITUMINOUS CONCRETE PAVEMENT (FULL DEPTH), TYPE 1 15 1/2"
- 12 EXISTING BITUMINOUS CONCRETE PAVEMENT (FULL DEPTH), TYPE 2 13 1/2"
- 13 EXISTING COMBINATION CONCRETE CURB AND GUTTER TYPE M-4.12
- 14 EXISTING CONCRETE MEDIAN SURFACE, 4"
- 20 PROPOSED HOT-MIX ASPHALT SURFACE REMOVAL, 2 1/4"
- 21 PROPOSED POLYMERIZED HOT-MIX ASPHALT BINDER COURSE, IL-19.0, N90 - (2 1/4")
- 22 PROPOSED POLYMERIZED HOT-MIX ASPHALT SURFACE COURSE, STONE MATRIX ASPHALT, N80 - (2")
- 23 PROPOSED BITUMINOUS MATERIALS (PRIMECOAT)
- 24 PROPOSED AGGREGATE (PRIMECOAT)
- 25 PROPOSED HOT-MIX ASPHALT SHOULDERS (2")
- 26 PROPOSED AGGREGATE SHOULDER, TYPE B
- 27 PROPOSED SHOULDER REMOVAL AND REPLACEMENT 12"
- 28 PROPOSED PIPE UNDERDRAIN 4"
- 29 PROPOSED SHOULDER REMOVAL AND REPLACEMENT 8"
- 30 PROPOSED HOT-MIX ASPHALT SURFACE REMOVAL, 1"
- 31 PROPOSED LEVELING BINDER (MACHINE METHOD), IL-9.5FG, N90 (1")
- 32 NOT USED
- 33 PROPOSED HOT-MIX ASPHALT SURFACE REMOVAL, 3"

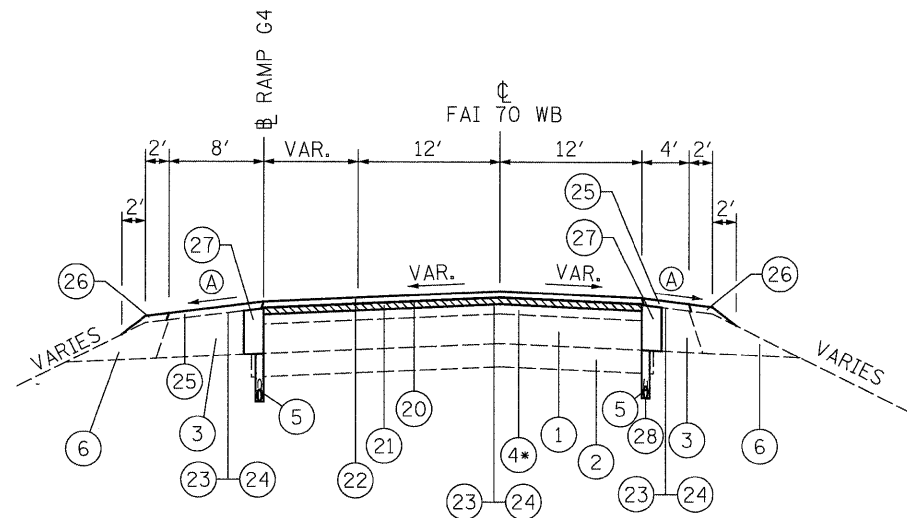

**RAMP TYPICAL SECTION  
FAI 70 WB & RAMP G4**

STA. 889+33 TO STA. 901+06 FAI 70 WB \* 4 3/4"

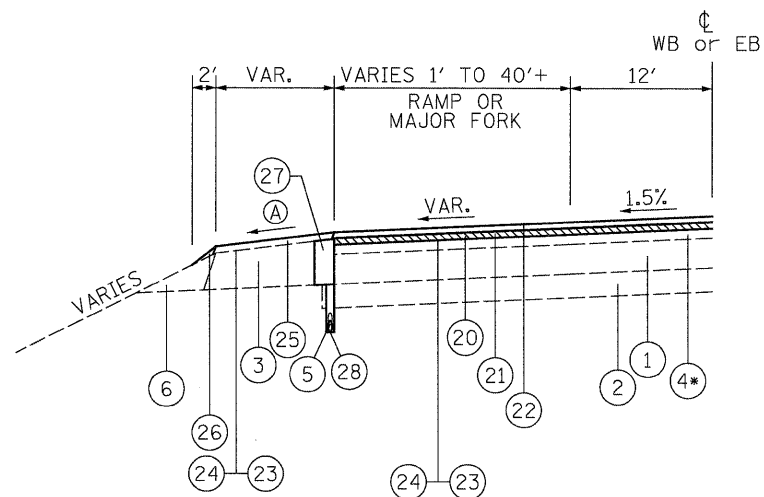

**RAMP TERMINAL TYPICAL SECTION  
(IL. 162 AND 3I INTERCHANGE)**

RAMP 1, 2, 3, & 4 @ IL. 162 \* 4 3/4"  
FAI 70 WB, FAI 70 EB @ 3I INTERCHANGE \* 4 3/4"  
RAMP G1, G3, G6 & G7 @ 3I INTERCHANGE \* 4 3/4"

(A) SHOULDER SLOPE  
RANGE FROM 2% TO 6%  
DESIRABLE 4%

**LEGEND**

- ① EXISTING P.C.C. PAVEMENT 10"
- ② EXISTING SUB-BASE GRANULAR MATERIAL, TYPE A 8"
- ③ EXISTING BITUMINOUS SHOULDER 12"±
- ④ EXISTING BITUMINOUS SURFACE COURSE 5 1/4"
- ⑤ EXISTING PIPE UNDERDRAINS
- ⑥ EXISTING AGGREGATE SHOULDERS
- ⑦ EXISTING HIGH TENSION CABLE MEDIAN BARRIER & HOT-MIX ASPHALT SHOULDER, 4" (4' WIDE)
- ⑧ EXISTING BITUMINOUS CONCRETE PAVEMENT (FULL DEPTH), TYPE 1 20 1/2"
- ⑨ EXISTING LIME MODIFIED SOIL, 12"
- ⑩ EXISTING BITUMINOUS SHOULDER 8"
- ⑪ EXISTING BITUMINOUS CONCRETE PAVEMENT (FULL DEPTH), TYPE 1 15 1/2"
- ⑫ EXISTING BITUMINOUS CONCRETE PAVEMENT (FULL DEPTH), TYPE 2 13 1/2"
- ⑬ EXISTING COMBINATION CONCRETE CURB AND GUTTER TYPE M-4.12
- ⑭ EXISTING CONCRETE MEDIAN SURFACE, 4"
- ⑯ PROPOSED HOT-MIX ASPHALT SURFACE REMOVAL, 2 1/4"
- ⑰ PROPOSED POLYMERIZED HOT-MIX ASPHALT BINDER COURSE, IL-19.0, N90 - (2 1/4")
- ⑱ PROPOSED POLYMERIZED HOT-MIX ASPHALT SURFACE COURSE, STONE MATRIX ASPHALT, N80 - (2")
- ⑲ PROPOSED BITUMINOUS MATERIALS (PRIMECOAT)
- ⑳ PROPOSED AGGREGATE (PRIMECOAT)
- ㉑ PROPOSED HOT-MIX ASPHALT SHOULDERS (2")
- ㉒ PROPOSED AGGREGATE SHOULDER, TYPE B
- ㉓ PROPOSED SHOULDER REMOVAL AND REPLACEMENT 12"
- ㉔ PROPOSED PIPE UNDERDRAIN 4"
- ㉕ PROPOSED SHOULDER REMOVAL AND REPLACEMENT 8"
- ㉖ PROPOSED HOT-MIX ASPHALT SURFACE REMOVAL, 1"
- ㉗ PROPOSED LEVELING BINDER (MACHINE METHOD), IL-9.5FG, N90 (1")
- ㉘ NOT USED
- ㉙ PROPOSED HOT-MIX ASPHALT SURFACE REMOVAL, 3"

FILE NAME =	USER NAME = SJS	DESIGNED -	REVISED -	<b>STATE OF ILLINOIS DEPARTMENT OF TRANSPORTATION</b>	<b>TYPICAL SECTIONS</b>			F.A.I. RTE.	SECTION	COUNTY	TOTAL SHEETS	SHEET NO.
... \D876A73-aht-typico1.dgn	PLOT SCALE = 8.0000' / IN.	DRAWN -	REVISED -					TO	*	MADISON	150	16
	PLOT DATE = 05/12/2009 09:16:44	CHECKED -	REVISED -		SCALE: SHEET NO. OF SHEETS STA. TO STA.			CONTRACT NO. 76A73				
		DATE -	REVISED -		FED. ROAD DIST. NO. ILLINOIS FED. AID PROJECT							

• 60-(7,8,9,10)RS, 60-(8,9,10)BR

## RESURFACING SCHEDULE

STATION TO STATION		POLY HMA SURFACE (2")	POLY HMA BINDER (2 1/4")	LEVEL BINDER (MM) (1") (mm)	BITUMINOUS (PRIME)	AGGREGATE (PRIME)	HMA SHOULDERS		AGGREGATE SHOULDERS TYPE B	HMA SURFACE REMOVAL (1")	HMA SURFACE REMOVAL (2 1/4")	HMA SURFACE REMOVAL (3")
							(WB)	(EB)				
	*SQ YD	TON	TON	TON	TON	TON	TON	TON	TON	SQ YD	SQ YD	SQ YD
<b>MAINLINE</b>												
564+60 TO 624+46	WB	17458	1955	2155	8.7	41.8	1169		104		17458	
564+60 TO 624+19	EB	15846	1775	1967	8.3	39.6		1182	123		15846	
OMISSION SN 060-0016/17												
626+50 TO 665+05	WB	13267	1486	1618	6.3	30.0	754		98		13267	
626+25 TO 664+95	EB	10319	1156	1285	5.4	25.8		771	49		10319	
665+05 TO 666+95	WB	507	57		0.3	1.3	38				844	
664+95 TO 666+85	EB	507	57		0.3	1.3		38			844	
666+95 TO 686+12	WB	5478	614	677	2.7	12.8	326		96		5118	
686+12 TO 689+12	WB	869	97	59	0.3	1.5	28		50		856	
OMISSION (WB) WEIGH-IN MOTION SLAB												
666+85 TO 704+63	EB	8955	1003	1115	4.5	21.7		616	77		8955	
689+12 TO 704+34	WB	3464	388	404	1.5	6.9	142		128		3092	
704+34 TO 711+37	WB				0.3	1.3	100				897	
704+63 TO 710+13	EB				0.2	1.1		80			712	
711+37 TO 792+12	WB	21798	2441	2733	11.3	53.9	1586		188		21798	
710+13 TO 791+82	EB	23869	2673	2986	11.7	55.9		1507	273		22954	
OMISSION SN 060-0018/19												
794+10 TO 856+00	WB	18791	2105	2354	9.2	44.0	1183		179		18791	
793+80 TO 856+00	EB	18895	2116	2367	9.3	44.4		1202	91		18895	
STATION EQUATION												
856+00 BK = 1382+94 AH												
1382+94 TO 1355+36	WB	8730	978	1086	4.2	20.1	521		70		8730	
1382+94 TO 1355+20	EB	8587	962	1060	4.2	20.2		547	35		8587	
OMISSION CONC. PAVEMENT UNDER IL 162												
1351+27 TO 1280+95	WB	27634	3095	3437	12.5	59.8	1370		165		27634	
1351+00 TO 1280+95	EB	24864	2785	2739	11.3	54.0		1247	124		21905	
1280+95 TO 1277+05	WB	1329	149		0.6	2.8	60				1868	
1280+95 TO 1277+05	EB	1749	196		0.7	3.4		59			2269	
1277+05 TO 1263+58	WB	3826	429	468	1.8	8.5	205		17		3826	
1277+05 TO 1263+58	EB	4151	465	509	2.0	9.4		238	34		4151	
<b>IL 159 INTERCHANGE</b>												
RAMP A 4+65 TO 13+58		2613	293	140	0.8	3.9			23		2496	
RAMP B 4+11 TO 9+11		1510	169	71	0.5	2.3			13		1388	
RAMP C 1+80 TO 11+45		2877	322	155	0.9	4.3			24		2760	
RAMP D 5+86 TO 20+44		4252	476	239	1.3	6.3			101		3830	
RAMP E 4+00 TO 9+33		1612	181	77	0.5	2.4			14		1492	
RAMP F 4+37 TO 11+09		1955	219	103	0.6	2.9			17		1839	
RAMP G 2+03 TO 12+53		3062	343	158	1.0	4.6			27		2946	
RAMP H 4+15 TO 19+07		4377	490	232	1.4	6.5			103		3897	
<b>US 40 INTERCHANGE</b>												
RAMP 1 106+10 TO 118+20		3529	395	191	1.1	5.3			31		3412	
RAMP 2 205+43 TO 227+41		6362	713	350	2.0	9.5			57		6246	
RAMP 3 300+60 TO 309+90		2707	303	145	0.8	4.1			23		2591	
RAMP 4 405+42 TO 416+15		3134	351	169	1.0	4.7			27		3015	
<b>US 40</b>												
132+87 TO 144+39	WB	3181	356	178	1.0	4.8						3181
132+87 TO 144+33	EB	2960	332	166	0.9	4.4						2960
OMISSION SN 060-0267												
147+14 TO 160+60	WB	4631	519	259	1.5	6.9						4631
147+08 TO 160+60	EB	4909	550	275	1.5	7.4						4909
<b>WEDGE FOR MOW STRIP **</b>												
SUBTOTAL =							229	462				
ADDITIONAL 15% TO CORRECT SHOULDER SLOPES							7711	7949				
TOTAL =		32,994	29,019	2908	134.4	641.8	17,905		2361	35,912	239,616	15,681

**PAVED SHOULDER REMOVAL**

LOCATION SQ. YD.  
 RAMP D, IL 159 INTERCHANGE RT. STA. 16+61.91 TO RT. STA. 727+37.21 1123  
 RAMP H, IL 159 INTERCHANGE LT. STA. 681+64.36 TO RT. STA. 14+72.56 1218  
 TOTAL = 2341

**PCC BASE COURSE 13"**

LOCATION SQ. YD.  
 RAMP D, IL 159 INTERCHANGE RT. STA. 16+61.91 TO RT. STA. 727+37.21 1276  
 RAMP H, IL 159 INTERCHANGE LT. STA. 681+64.36 TO RT. STA. 14+72.56 1628  
 TOTAL = 2904

**SUB-BASE GRANULAR MATERIAL, TYPE A 8"**

LOCATION SQ. YD.  
 RAMP D, IL 159 INTERCHANGE RT. STA. 16+61.91 TO RT. STA. 727+37.21 1510  
 RAMP H, IL 159 INTERCHANGE LT. STA. 681+64.36 TO RT. STA. 14+72.56 1897  
 TOTAL = 3407

**TIE BARS 3/4" (30" LENGTH)**  
 (SEE PATCHING SCHEDULE FOR ADDITIONAL TIE BARS)

LOCATION EACH  
 RAMP D, IL 159 INTERCHANGE RT. STA. 16+61.91 TO RT. STA. 727+37.21 561  
 RAMP H, IL 159 INTERCHANGE LT. STA. 681+64.36 TO RT. STA. 14+72.56 633  
 TOTAL = 1194

**HOT-MIX ASPHALT SHOULDERS, 8"**

LOCATION SQ. YD.  
 RAMP D, IL 159 INTERCHANGE RT. STA. 16+61.91 TO RT. STA. 727+37.21 979  
 RAMP H, IL 159 INTERCHANGE LT. STA. 681+64.36 TO RT. STA. 14+72.56 1096  
 TOTAL = 2075

**HOT-MIX ASPHALT SURFACE REMOVAL, VARIABLE DEPTH**

LOCATION SQ. YD.  
 US 40:  
 RAMP 1 STA. 106+10 TO STA. 106+50 116  
 RAMP 2 STA. 227+01 TO STA. 227+41 116  
 RAMP 3 STA. 300+60 TO STA. 301+00 116  
 RAMP 4 STA. 415+75 TO STA. 416+15 116  
 I-70:  
 EB RAMP STA. 903+94 TO STA. 904+34 169  
 WB RAMP STA. 901+06 TO STA. 901+46 230  
 I-270:  
 RAMP G1 STA. 2+72 TO STA. 3+12 104  
 RAMP G3 STA. 7+00 TO STA. 7+40 124  
 RAMP G6 STA. 1+78 TO STA. 2+18 115  
 RAMP G7 STA. 15+52 TO STA. 15+82 80  
 TOTAL = 1286

\*AREAS SHOWN ARE ONLY FOR SURFACE CSE. CALCULATIONS (BY MICROSTATION)  
 SEE JOINT DETAIL SHEET  
 HMA - 112lb/sy/ln

\*\* WEDGE IS 2' WIDE AND 1.375" AVERAGE DEPTH.  
 (SEE DETAIL BIT. TAPER @ CABLE MEDIAN BARRIER)

\* 60-(7,8,9,10)RS, 60-(8,9,10)BR





**REMOVE CONCRETE FOUNDATION**

LOCATION	OBJECT	EACH
FAI 55/70:		
LT. STA. 592+00	CALLBOX FOUND	1
LT. STA. 645+00	CALLBOX FOUND	1
RT. STA. 702+00	CALLBOX FOUND	1
LT. STA. 757+00	CALLBOX FOUND	1
RT. STA. 780+00	CALLBOX FOUND	1
LT. STA. 825+00	CALLBOX FOUND	1
TOTAL = 6		

**IMPACT ATTENUATOR REMOVAL  
IMPACT ATTENUATORS (NON-REDIRECTIVE), TEST LEVEL 3**

LOCATION	OBJECT	(REMOVAL) EACH	(NEW) EACH
FAI 55/70:			
STA. 810+00 (MEDIAN)	SIGN SUPPORT	1	1
STA. 833+90 (MEDIAN)	PIER	1	1
STA. 840+00 (MEDIAN)	SIGN SUPPORT	1	1
STA. 1352+70 (MEDIAN)	PIER	1	1
		TOTAL = 4	TOTAL = 4

**SIGN PANEL - TYPE 3**

LOCATION	SIGN PANEL-TYPE 3 SQ. FT.
FAI 55/70:	
LT. STA. 659+64 (8C060I055L013.9)	100.75
RT. STA. 698+50 (8S060I055R014.3)	166.75
	199.50
RT. STA. 706+00 (8C060I055R014.5)	199.50
LT. STA. 710+00 (8C060I055L014.5)	92
LT. STA. 717+00 (8S060I055L014.8)	178.25
	189
	198
RT. STA. 803+00 (8S060I055R016.4)	168.75
	198
RT. STA. 810+00 (8S060I055R016.6)	192
	216
LT. STA. 155+81 (US 40) (8S060I055R017.0)	222.75
	171
LT. STA. 840+00 (8S060I055L017.2)	192
	150
LT. STA. 1336+54 (8S060I055R017.8)	198
RELOCATE TO LT. STA. 1363+75	99
	175
RT. STA. 1341+00 (8S060I055L018.3)	99
	200
LT. STA. 1322+00 (8C060I055R018.7)	150
LT. STA. 1305+10 (8S060I055R019.0)	184
	189.75
	195
LT. STA. 1281+00 (8C060I055R019.4)	200
RT. STA. 1278+00 (8C060I055L019.5)	109.25
RT. STA. 1268+64 (8S060I055L019.7)	181.25
	195
TOTAL = 5198.75	

**TREE REMOVAL, ACRES**

LOCATION	MILE MARKER	DESCRIPTION	ACRE
RT. STA. 565+00 TO STA. 574+16	(12.0 TO 12.2)	HEAVY GROWTH AREA	0.88
LT. STA. 565+00 TO STA. 580+84	(12.0 TO 12.3)	HEAVY GROWTH AREA	1.09
RT. STA. 586+12 TO STA. 601+96	(12.4 TO 12.7)	BRUSH AND TREES	0.47
RT. STA. 607+24 TO STA. 625+31	(12.8 TO 13.1)	HEAVY GROWTH AREA	1.24
RT. STA. 625+31 TO STA. 630+59	(13.1 TO 13.2)	TREES IN DRAINAGE DITCH AND BEHIND LOGO SIGN	1.38
RT. STA. 635+87	(13.3)	GUARD RAIL ACROSS FROM WEIGH SCALE STATION	0.19
RT. STA. 671+16	(14.0)	LARGE TREES OVERHANGING RDWY.	0.22
LT. STA. 676+44	(14.1)	SYCAMORE AND MISCELL. TREES	0.11
LT. STA. 727+56	(15)	TREES IN ACCESS CONTROL FENCE ALONG FRONTAGE RD.	0.11
LT. STA. 766+56	(15.6)	LARGE SYCAMORE	0.03
RT. STA. 766+56 TO STA. 771+84	(15.6 TO 15.7)	LARGE TREES OVERHANGING RDWY.	0.55
RT. STA. 1336+54 TO STA. 1368+82	(17.7 TO 17.8)	WILLOW TREES IN DITCH	0.55
TOTAL =			6.82

NOTE:  
THE ENGINEER SHALL CONTACT IDOT OPERATIONS TO VERIFY LIMITS BEFORE BEGINNING WORK.

**SEEDING, CLASS 2**

	ACRE	NOTE: MULCH, METHOD 2 AND TEMPORARY EROSION CONTROL SEEDING SAME LOCATIONS AS SEEDING, CLASS 2
TREE REMOVAL AREA	6.82	
PIPE UNDERDRAIN OUTLETS	0.09	
SHOULDER WIDENING	0.16	
TYPE 1 (SPECIAL) TANGENT TERMINALS		
TOTAL =		7.07

**FURNISHED EXCAVATION**

	CU YD	
SHOULDER WIDENING	105	
TYPE 1 (SPECIAL) TANGENT TERMINALS		
TOTAL =		105

FENCE REPAIR & GATE PLACEMENT			
LOCATION	WOVEN WIRE FENCE 4'	WOVEN WIRE GATES, 4'x4' SINGLE	COMMENTS
EB/NB I-55/70			
STA. 749+00	200		
STA. 775+43	100		
STA. 801+85	100		
STA. 812+40	100		
STA. 844+10	100		LIGHT POLE 30
STA. 854+65	200		EXIT SIGN FOR IL 162
STA. 1374+45	300		NEAR FUEL SIGN
STA. 1369+15	100		
STA. 1342+75	100		NEAR COUNTRY VIEW ENTRANCE
STA. 1337+45	200		NEAR TRUCK WASH
STA. 1332+20	300		NEAR SPEEDCO
STA. 1316+35	200		NEAR LEBLER RD. CURVE
WB/SB I-55/70			
STA. 625+31 - 593+63	600		
STA. 681+82	500	1	GRADE SCHOOL/LUTHERAN CHURCH*
STA. 718+78 - 724+06	300		
STA. 933+83 - 944+39	600		
STA. 886+31	200		
STA. 1369+14	100		
STA. 1363+86	200		NEAR LONG BRANCH RD.
STA. 1263+80	200		
TOTAL =	4700	1	

\*CONTACT OPERATIONS (STAN RUDY) FOR EXACT LOCATION OF GATE

**GRADING AND SHAPING DITCHES**

LOCATION	FOOT
RT. STA. 581+50 - 582+50	100
RT. STA. 662+00 - 662+50	50
LT. STA. 685+50 - 688+50	300
RT. STA. 688+50 - 689+50	100
RT. STA. 712+00 - 712+50	50
RT. STA. 373+00 - 371+00	200
RT. STA. 364+50 - 363+50	100
TOTAL =	900

REMOVAL OF EXISTING LIGHTING UNIT, SALVAGE SCHEDULE							
LOCATION	STATION	STRUCTURE #	CONTROLLER LOCATION	CIRCUIT DESCRIPTION	REMOVE SIGN LIGHTING CONDUIT	SALVAGE SIGN LIGHTING FIXTURES AND DISCONNECT SWITCH	RE-ESTABLISH CIRCUIT WITH EXIST. SIGN TRUSS HANDHOLE
Wweigh Station	659+64	8C060I055L013.9	In the Scale House	Between #2 (45+50) and #1 (48+30) w/#6 UD	1	1	1
IL 159	698+50	8S060I055R014.3	NE Quad. Between Frontage Road and WB I-55/70 Ramp onto NB IL 159	Off Light Pole #18 (5+45)	1	1	
IL 159	706+00	8C060I055R014.5		Off Light Pole #24 (707+00)	1	1	
IL 159	710+00	8C060I055L014.5		Off Light Pole #25 (709+40)	1	1	
IL 159	717+00	8S060I055L014.8		Off Light Pole #29 (5+00)	1	1	
US 40	803+00	8S060I055R016.4	Between Ramp 2 and the South Frontage Road	Off Light Pole #5 (808+75)	1	1	
US 40	810+00	8S060I055R016.6		Off Light Pole #6 (202+20)	1	1	
US 40	155+81	8S060I055R017.0		Off Light Pole #23 (157+50)	1	1	
US 40	840+00	8S060I055L017.2		Off Light Pole #13 (837+10)	1	1	
IL 162	1363+75	8S060I055R017.8	At Frontage Road A @ Ramp 2 off I-55/70	Between the Controller and Light Pole #13 (3+60) w/#6 UD	1	1	1
IL 162	1341+00	8S060I055L018.3	On IL 162 Between Ramp 3 and Frontage Road C	Off Light Pole #2 (4+00)	1	1	
3I	1322+00	8S060I055R018.7	1303+00 at the EB I-70 Ramp	Off Light Pole #26 (893+00)	1	1	
3I	1305+10	8S060I055R019.0		Off Light Pole #22 (904+20)	1	1	
3I	1281+00	8C060I055R019.4		Off Light Pole #17 (860+95)	1	1	
3I	1278+00	8C060I055L019.5		Off Light Pole #3 (1277+70)	1	1	
3I	1268+64	8S060I055L019.7		Off Light Pole #2 (1267+00)	1	1	
REMOVAL OF EXISTING LIGHTING UNIT, SALVAGE						14 EACH	



**GUARDRAIL SCHEDULE**

STATION TO STATION	STEEL PLATE BEAM GUARD RAIL TYPE A 6 FOOT POSTS	TRAFFIC BARRIER TERMINAL TYPE 2	TRAFFIC BARRIER TERMINAL TYPE 5	TRAFFIC BARRIER TERMINAL TYPE 6	TRAFFIC BARRIER TERMINAL TYPE 6A	TRAFFIC BARRIER TERMINAL TYPE 6B	TRAFFIC BARRIER TERMINAL TYPE 1 (SPL) TANGENT	GUARDRAIL MARKERS TYPE A	TERMINAL MARKER DIRECT APPLIED
	FOOT	EACH	EACH	EACH	EACH	EACH	EACH	EACH	EACH
<b>MAINLINE</b>									
LT. 564+60.00 TO LT. 580+10.00	1,500.0						1	7	1
RT. 581+16.11 TO RT. 587+30.90	550.0	1					1	5	1
RT. 591+82.11 TO RT. 602+96.90	1,050.0	1					1	6	1
LT. 595+36.54 TO LT. 624+91.00	2,925.0	1	1					11	
RT. 610+60.11 TO RT. 615+49.90	425.0	1					1	5	1
RT. 622+14.10 TO RT. 624+58.00	150.0				1		1	4	1
RT. 622+27.10 TO RT. 624+71.00	150.0				1		1	4	1
LT. 626+04.00 TO LT. 628+59.65	162.5			1			1	4	1
LT. 626+23.00 TO LT. 628+53.65	137.5			1			1	4	1
RT. 625+73.00 TO RT. 639+44.19	1312.5	1			1			7	
RT. 662+11.35 TO RT. 665+67.00	262.5					1	1	4	1
RT. 665+83.00 TO RT. 677+03.44	1062.5	1				1		6	
LT. 666+11.00 TO LT. 685+16.65	1812.5					1	1	8	1
RT. 690+20.14 TO RT. 698+63.36	187.5	1					1	4	1
LT. 716+88.79 TO LT. 719+66.08	212.5	1					1	4	1
RT. 749+88.61 TO RT. 757+90.90	737.5	1					1	6	1
LT. 758+72.10 TO LT. 771+86.89	1,250.0	1					1	7	1
RT. 784+84.35 TO RT. 791+90.00	612.5			1			1	5	1
RT. 789+24.35 TO RT. 792+05.00	187.5			1			1	4	1
LT. 791+03.54 TO LT. 792+33.00	100.0	1	1					4	
RT. 793+59.00 TO RT. 806+25.96	1,237.5	1	1					7	
LT. 793+87.00 TO LT. 796+67.65	187.5			1			1	4	1
LT. 794+02.00 TO LT. 809+32.65	1,437.5			1			1	7	1
LT. 803+10.23 TO LT. 806+75.02	300.0	1					1	4	1
<b>STATION EQUATION</b>									
856+00 BK = 1382+94 AH									
RT. 1360+04.19 TO RT. 1363+68.98	300.0	1					1	4	1
LT. 1353+51.00 TO LT. 1358+31.65	387.5					1	1	5	1
RT. 1348+11.35 TO RT. 1352+92.00	387.5					1	1	5	1
RT. 1338+04.63 TO RT. 1341+06.92	237.5	1					1	4	1
LT. 1305+04.93 TO LT. 1308+44.72	275.0	1					1	4	1
LT. 1291+53.38 TO LT. 1296+05.67	387.5	1					1	5	1
LT. 1291+11.00 TO LT. 1295+04.15	300.0					1	1	4	1
RT. 1288+13.85 TO RT. 1292+32.00	325.0					1	1	5	1
LT. 1278+39.67 TO LT. 1284+04.46	500.0	1					1	5	1
RT. 1274+57.35 TO RT. 1279+63.00	412.5					1	1	5	1
LT. 1268+73.23 TO LT. 1272+75.52	337.5	1					1	5	1
<b>IL 159:</b>									
RT. 1+28.63 TO RT. 3+80.92 (RAMP A)	187.5	1					1	4	1
RT. 9+14.20 TO RT. 10+41.49 (RAMP B)	62.5	1					1	4	1
RT. 1+51.78 TO RT. 3+79.07 (RAMP F)	162.5	1					1	4	1
<b>IL 162:</b>									
RT. 0+25.49 TO RT. 3+27.78 (RAMP 4)	237.5	1					1	4	1
<b>I-70:</b>									
RT. 900+89.42 TO RT. 903+04.21 (EB RAMP)	150.0	1					1	4	1
<b>I-270:</b>									
LT. 1278+44.00 TO RT. 11+27.60 (RAMP G7)	637.5					1	1	10	1
<b>TOTAL =</b>	<b>23,237.5</b>	<b>24</b>	<b>3</b>	<b>6</b>	<b>3</b>	<b>9</b>	<b>36</b>	<b>212</b>	<b>36</b>

**GUARDRAIL REMOVAL**

STATION TO STATION	LENGTH
	FOOT
<b>MAINLINE</b>	
LT. 564+60 TO LT. 578+00	1,340
RT. 584+23 TO RT. 586+99	276
RT. 594+60 TO RT. 603+25	865
LT. 595+87 TO LT. 605+14	927
LT. 608+63 TO LT. 624+96	1,633
RT. 611+80 TO RT. 615+60	380
RT. 621+62 TO RT. 624+70 (MEDIAN)	308
RT. 622+45 TO RT. 624+55	210
LT. 625+95 TO LT. 628+20 (MEDIAN)	225
LT. 626+15 TO LT. 628+13	198
RT. 632+10 TO RT. 638+25	615
RT. 662+41 TO RT. 665+91	350
LT. 665+88 TO LT. 668+25	237
RT. 671+17 TO RT. 675+54	437
LT. 671+64 TO LT. 681+50	986
RT. 697+66 TO RT. 698+80 (MEDIAN)	114
LT. 716+67 TO LT. 717+83 (MEDIAN)	116
LT. 758+18 TO LT. 761+46	328
LT. 764+42 TO LT. 769+50	508
RT. 788+52 TO RT. 791+90	338
RT. 788+66 TO RT. 792+05 (MEDIAN)	339
LT. 791+31 TO LT. 792+33	102
RT. 793+59 TO RT. 805+24	1,165
LT. 793+87 TO LT. 797+32 (MEDIAN)	345
LT. 794+02 TO LT. 806+51	1,249
LT. 802+88 TO LT. 806+16 (MEDIAN)	328
<b>STATION EQUATION</b>	
856+00 BK = 1382+94 AH	
LT. 1363+45 TO LT. 1366+00	255
RT. 1361+06 TO RT. 1363+90 (MEDIAN)	284
LT. 1352+71 TO LT. 1357+08	437
RT. 1349+31 TO RT. 1353+69	438
RT. 1338+89 TO RT. 1341+09 (MEDIAN)	220
RT. 1338+60 TO RT. 1341+00	240
LT. 1305+07 TO LT. 1308+19 (MEDIAN)	312
LT. 1291+07 TO LT. 1294+07	300
LT. 1291+07 TO LT. 1293+48 (MEDIAN)	241
RT. 1289+55 TO RT. 1292+38	283
RT. 1278+72 TO RT. 1279+87	115
LT. 1278+24 TO LT. 1279+42	118
LT. 1278+08 TO LT. 1281+34 (MEDIAN)	326
RT. 1275+35 TO RT. 1278+47	312
LT. 1268+45 TO LT. 1270+71	226
<b>IL 159:</b>	
RT. 1+53 TO RT. 4+00 (RAMP A)	247
RT. 9+44 TO RT. 11+23 (RAMP B)	179
RT. 9+44 TO RT. 11+40 (RAMP E)	196
RT. 1+62 TO RT. 4+05 (RAMP F)	243
<b>I-70:</b>	
RT. 899+83 TO RT. 905+30 (EB RAMP)	547
<b>I-270:</b>	
LT. 1279+66 TO RT. 11+23 (RAMP G7)	594
<b>TOTAL =</b>	<b>20,032</b>

\* 60-(7,8,9,10)RS, 60-(8,9,10)BR

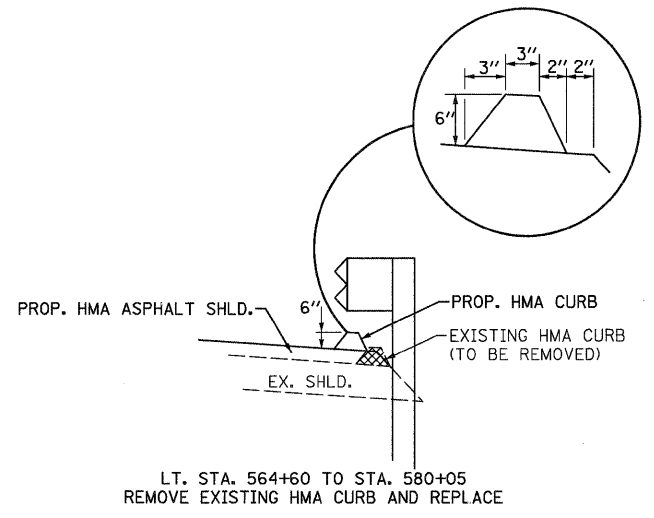
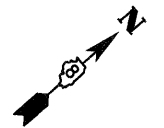

LT. STA. 564+60  
CONTRACTOR SHALL COORDINATE GUARDRAIL  
REMOVAL AND REPLACEMENT (AS DIRECTED BY  
THE ENGINEER) WITH THE CONTRACT  
TO THE WEST OF THIS PROJECT.

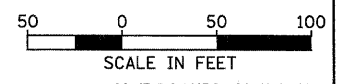
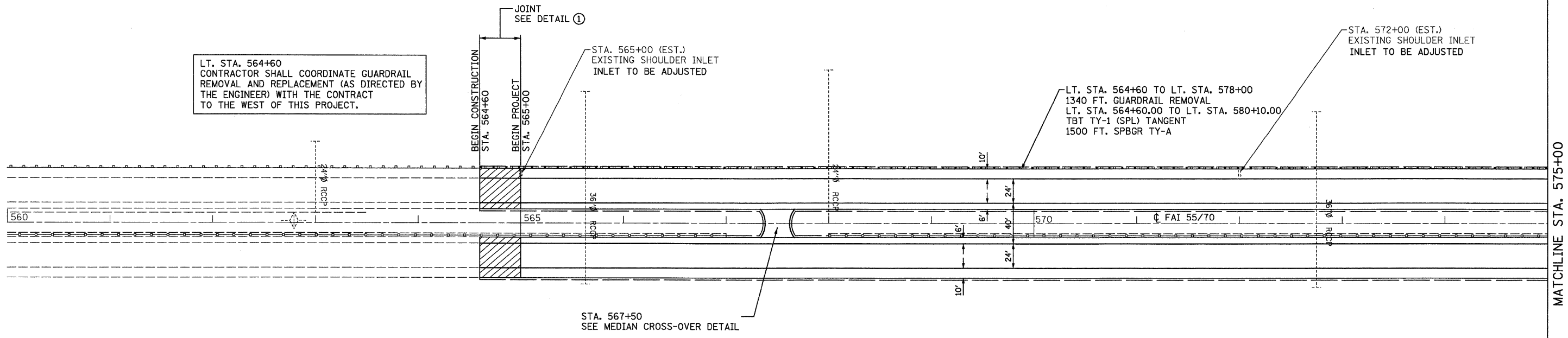

FILE NAME = ... \0876A73-sht-plan.dgn 	USER NAME = SJS	DESIGNED -	REVISED -	<b>STATE OF ILLINOIS DEPARTMENT OF TRANSPORTATION</b>	<b>F.A.I. ROUTE 70 ROADWAY PLANS</b>	F.A.I. RTE. 70	SECTION *	COUNTY MADISON	TOTAL SHEETS 150	SHEET NO. 22
	PLOT SCALE = 50.0000' / IN. PLOT DATE = 06/12/2009 09:17:33	DRAWN - CHECKED - DATE -	REVISED - REVISED - REVISED -			SCALE: 1' = 50' SHEET NO. OF SHEETS STA. 560+00 TO STA. 575+00	FED. ROAD DIST. NO. ILLINOIS FED. AID PROJECT	CONTRACT NO. 76A73		

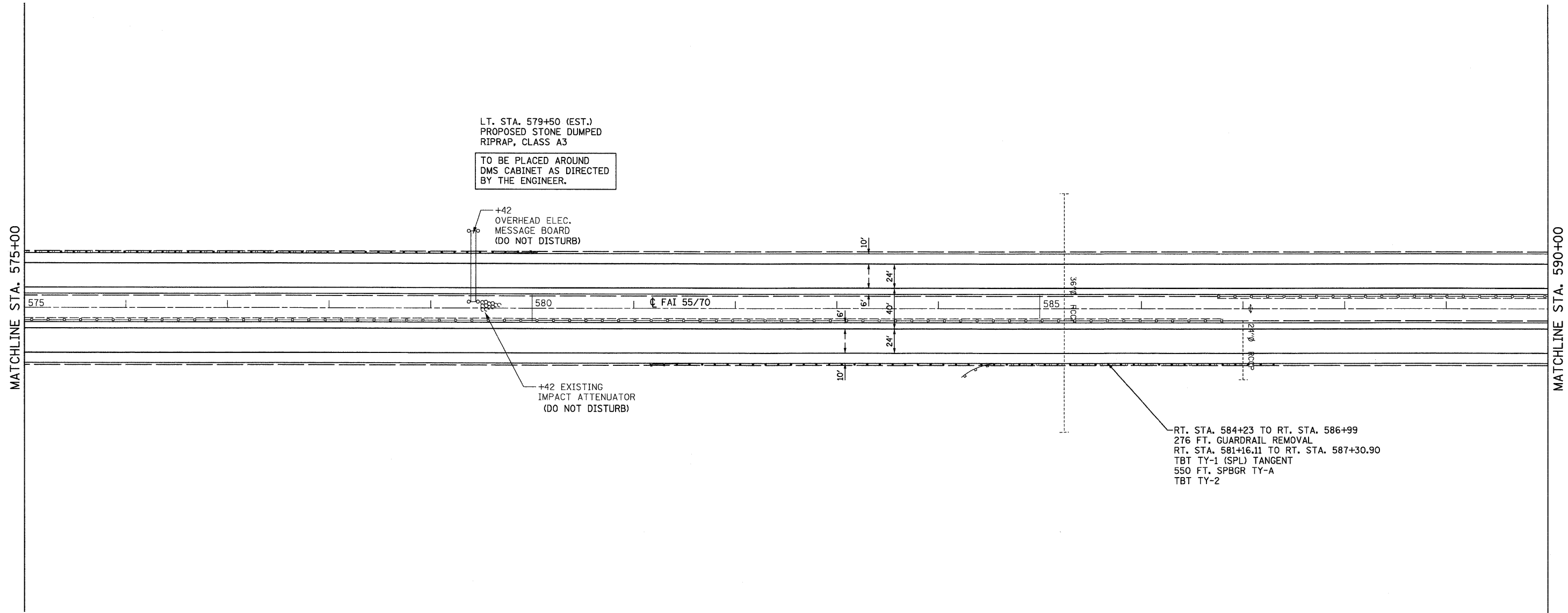
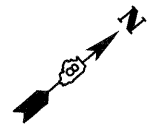

LT. STA. 579+50 (EST.)  
 PROPOSED STONE DUMPED  
 RIPRAP, CLASS A3  
 TO BE PLACED AROUND  
 DMS CABINET AS DIRECTED  
 BY THE ENGINEER.

+42  
 OVERHEAD ELEC.  
 MESSAGE BOARD  
 (DO NOT DISTURB)

+42 EXISTING  
 IMPACT ATTENUATOR  
 (DO NOT DISTURB)

RT. STA. 584+23 TO RT. STA. 586+99  
 276 FT. GUARDRAIL REMOVAL  
 RT. STA. 581+16.11 TO RT. STA. 587+30.90  
 TBT TY-1 (SPL) TANGENT  
 550 FT. SPBGR TY-A  
 TBT TY-2

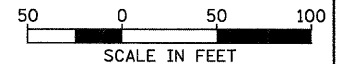

FILE NAME = ... \087673-ahp-plan02.dgn	USER NAME = SJS	DESIGNED -	REVISED -
Johnson, Depp & Quisenberry CONSULTING ENGINEERS Springfield, Illinois	PLOT SCALE = 50.0000' / IN.	DRAWN -	REVISED -
PLOT DATE = 06/12/2009 09:17:46	DATE -	CHECKED -	REVISED -

**STATE OF ILLINOIS  
 DEPARTMENT OF TRANSPORTATION**

**F.A.I. ROUTE 70  
 ROADWAY PLANS**

SCALE: 1" = 50'    SHEET NO.    OF    SHEETS    STA. 575+00    TO    STA. 590+00

F.A.I. RTE.	SECTION	COUNTY	TOTAL SHEETS	SHEET NO.
70	*	MADISON	150	23
FED. ROAD DIST. NO.    ILLINOIS FED. AID PROJECT			CONTRACT NO. 76A73	

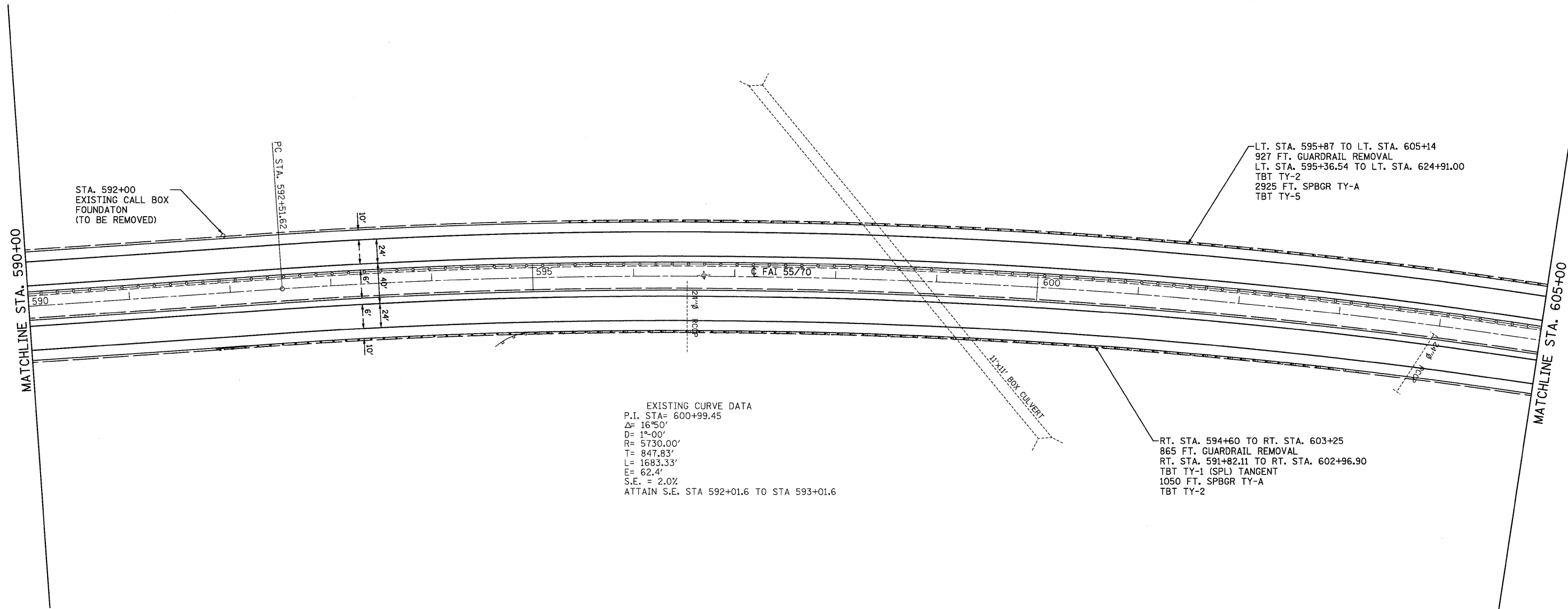
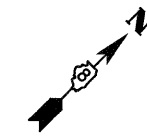

STA. 592+00  
EXISTING CALL BOX  
FOUNDATON  
(TO BE REMOVED)

LT. STA. 595+87 TO LT. STA. 605+14  
927 FT. GUARDRAIL REMOVAL  
LT. STA. 595+36.54 TO LT. STA. 624+91.00  
TBT TY-2  
2925 FT. SPBGR TY-A  
TBT TY-5

EXISTING CURVE DATA  
P.I. STA= 600+99.45  
Δ= 16°50'  
D= 1°-00'  
R= 5730.00'  
T= 847.83'  
L= 1683.33'  
E= 62.4'  
S.E. = 2.0%  
ATTAIN S.E. STA 592+01.6 TO STA 593+01.6

RT. STA. 594+60 TO RT. STA. 603+25  
865 FT. GUARDRAIL REMOVAL  
RT. STA. 591+82.11 TO RT. STA. 602+96.90  
TBT TY-1 (SPL) TANGENT  
1050 FT. SPBGR TY-A  
TBT TY-2

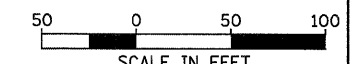

SCALE IN FEET  
• 60-(7,8,9,10)RS, 60-(8,9,10)BR

FILE NAME = ...N0876A73-shr-plan03.dgn 	USER NAME = SJS	DESIGNED -	REVISED -	<b>STATE OF ILLINOIS</b> <b>DEPARTMENT OF TRANSPORTATION</b>	<b>F.A.I. ROUTE 70</b> <b>ROADWAY PLANS</b>			F.A.I. RTE. 70	SECTION •	COUNTY MADISON	TOTAL SHEETS /50	SHEET NO. 24
	PLOT SCALE = 50.0000' / IN. PLOT DATE = 08/12/2009 09:17:58	DRAWN - CHECKED - DATE -	REVISED - REVISED - REVISED -		SCALE: 1" = 50' SHEET NO. OF SHEETS STA. 590+00 TO STA. 605+00	CONTRACT NO. 76A73 FED. ROAD DIST. NO. ILLINOIS FED. AID PROJECT						

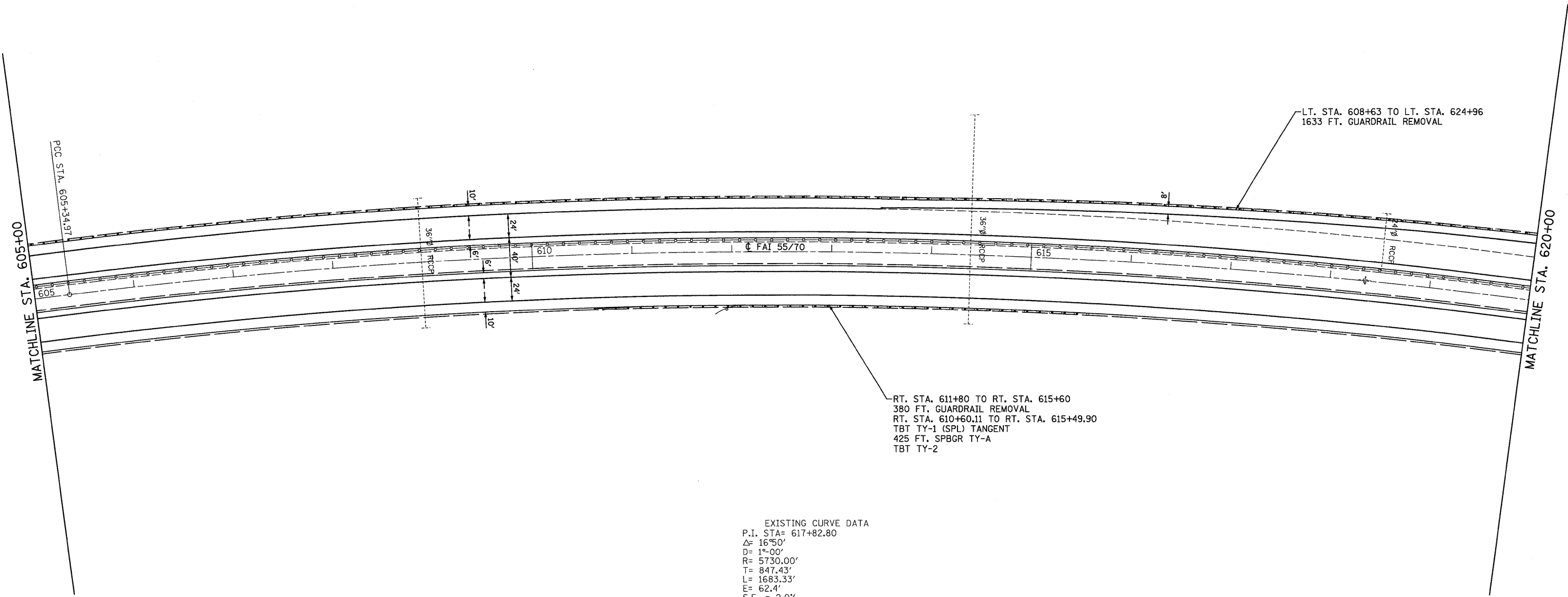

EXISTING CURVE DATA  
 P.I. STA= 617+82.80  
 $\Delta = 16^{\circ}50'$   
 $D = 1^{\circ}00'$   
 $R = 5730.00'$   
 $T = 847.43'$   
 $L = 1683.33'$   
 $E = 62.4'$   
 $S.E. = 2.0\%$   
 ATTAIN S.E. STA 626+68.3 TO STA 625+68.3

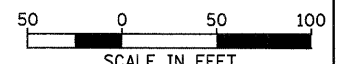

FILE NAME = ... \0876A73-shr-plan04.dgn 	USER NAME = SJS	DESIGNED -	REVISED -	<b>STATE OF ILLINOIS</b> <b>DEPARTMENT OF TRANSPORTATION</b>	<b>F.A.I. ROUTE 70</b> <b>ROADWAY PLANS</b>		F.A.I. RTE. 70	SECTION *	COUNTY MADISON	TOTAL SHEETS 150	SHEET NO. 25
	PLOT SCALE = 50.0000' / IN. PLOT DATE = 06/12/2009 09:18:13	DRAWN - CHECKED - DATE -	REVISED - REVISED - REVISED -		SCALE: 1' = 50' SHEET NO. OF SHEETS STA. 605+00 TO STA. 620+00	FED. ROAD DIST. NO. ILLINOIS FED. AID PROJECT	CONTRACT NO. 76A73				

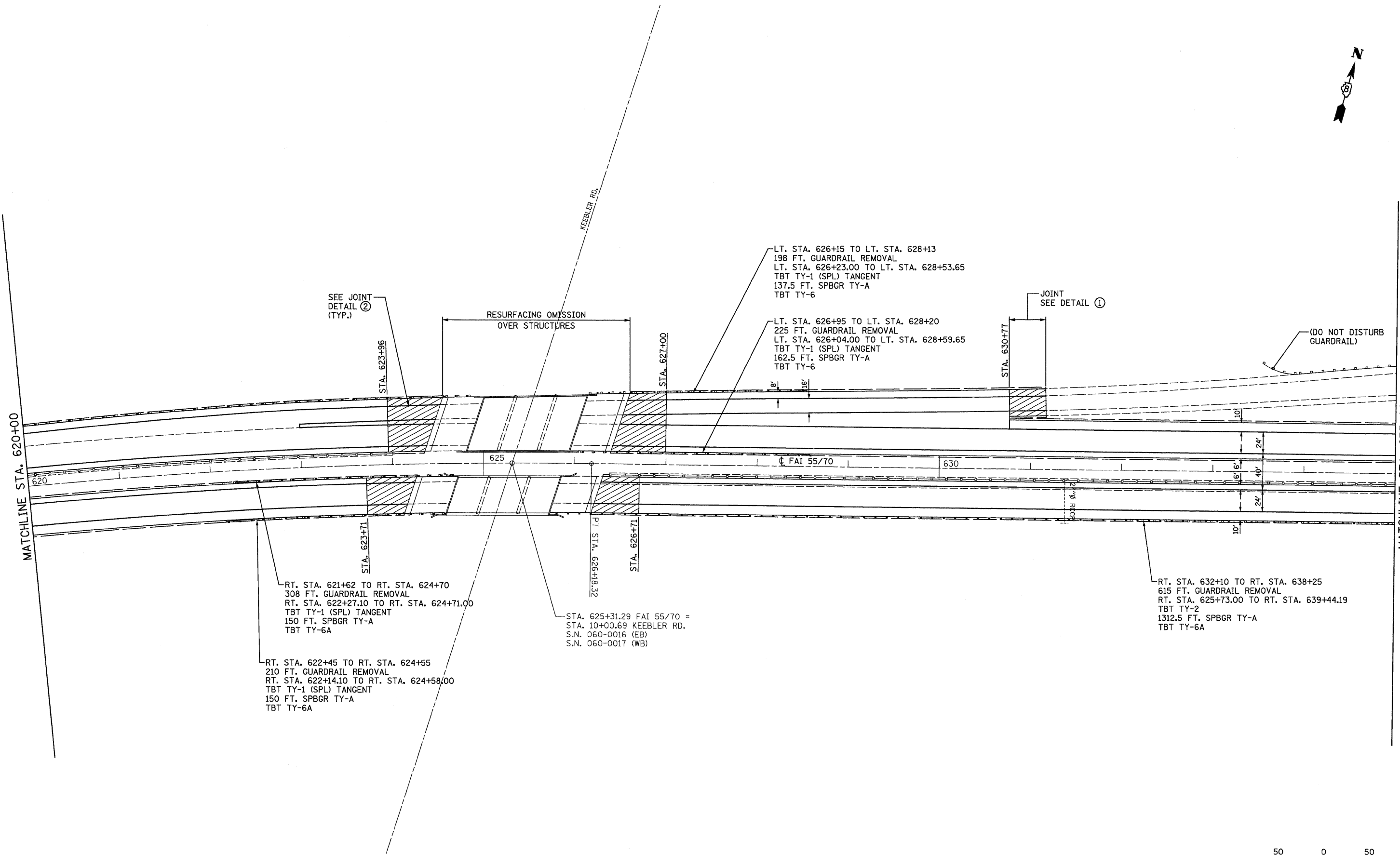

SEE JOINT  
DETAIL ②  
(TYP.)

RESURFACING OMISSION  
OVER STRUCTURES

LT. STA. 626+15 TO LT. STA. 628+13  
198 FT. GUARDRAIL REMOVAL  
LT. STA. 626+23.00 TO LT. STA. 628+53.65  
TBT TY-1 (SPL) TANGENT  
137.5 FT. SPBGR TY-A  
TBT TY-6

JOINT  
SEE DETAIL ①

(DO NOT DISTURB  
GUARDRAIL)

RT. STA. 621+62 TO RT. STA. 624+70  
308 FT. GUARDRAIL REMOVAL  
RT. STA. 622+27.10 TO RT. STA. 624+71.00  
TBT TY-1 (SPL) TANGENT  
150 FT. SPBGR TY-A  
TBT TY-6A

STA. 625+31.29 FAI 55/70 =  
STA. 10+00.69 KEEBLER RD.  
S.N. 060-0016 (EB)  
S.N. 060-0017 (WB)

RT. STA. 632+10 TO RT. STA. 638+25  
615 FT. GUARDRAIL REMOVAL  
RT. STA. 625+73.00 TO RT. STA. 639+44.19  
TBT TY-2  
1312.5 FT. SPBGR TY-A  
TBT TY-6A

RT. STA. 622+45 TO RT. STA. 624+55  
210 FT. GUARDRAIL REMOVAL  
RT. STA. 622+14.10 TO RT. STA. 624+58.00  
TBT TY-1 (SPL) TANGENT  
150 FT. SPBGR TY-A  
TBT TY-6A

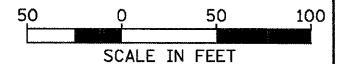

FILE NAME =  
... \0876A73-eh-t-plan@5.dgn  
**JD Johnson, Depp & Gilsenberry**  
CONSULTING ENGINEERS  
Springfield, Illinois

USER NAME = SJS  
DESIGNED -  
DRAWN -  
CHECKED -  
DATE -  
PLOT SCALE = 50.0000' / IN.  
PLOT DATE = 08/12/2009 09:18:27

DESIGNED -  
DRAWN -  
CHECKED -  
DATE -  
REVIS

REVIS  
REVIS  
REVIS  
REVIS

**STATE OF ILLINOIS  
DEPARTMENT OF TRANSPORTATION**

**F.A.I. ROUTE 70  
ROADWAY PLANS**

SCALE: 1" = 50' SHEET NO. OF SHEETS STA. 620+00 TO STA. 635+00

F.A.I. RTE.	SECTION	COUNTY	TOTAL SHEETS	SHEET NO.
70	*	MADISON	150	26
FED. ROAD DIST. NO.			ILLINOIS FED. AID PROJECT	

\* 60-(7,8,9,10)RS, 60-(8,9,10)BR

CONTRACT NO. 76A73



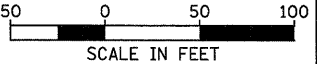
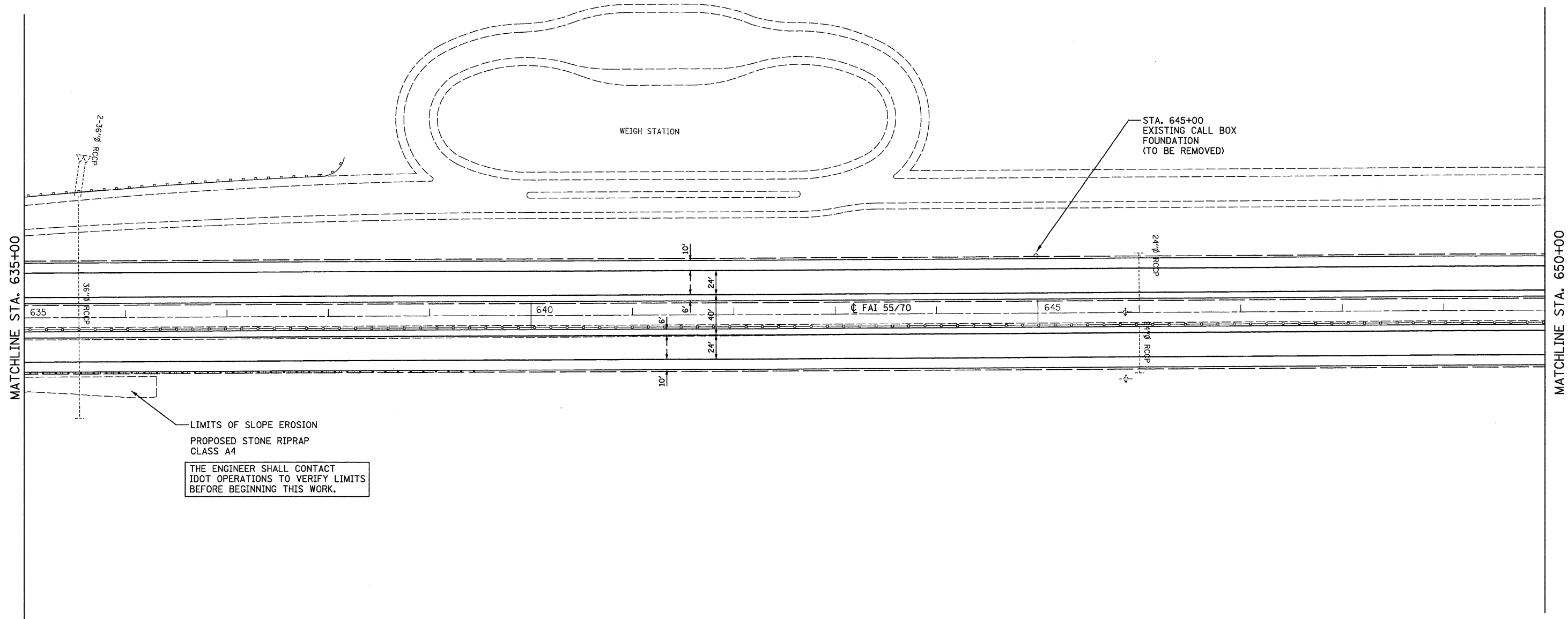

• 60-(7,8,9,10)RS, 60-(8,9,10)BR

FILE NAME = ... \0876A73-sht-plan06.dgn 	USER NAME = SJS	DESIGNED -	REVISED -	<b>STATE OF ILLINOIS</b> <b>DEPARTMENT OF TRANSPORTATION</b>	<b>F.A.I. ROUTE 70</b> <b>ROADWAY PLANS</b>	F.A.I. RTE. 70	SECTION *	COUNTY MADISON	TOTAL SHEETS 150	SHEET NO. 27
	PLOT SCALE = 50.0000' / IN. PLOT DATE = 06/12/2009 09:18:41	DRAWN - CHECKED - DATE -	REVISED - REVISED - REVISED -			SCALE: 1' = 50' SHEET NO. OF SHEETS STA. 635+00 TO STA. 650+00	FED. ROAD DIST. NO. ILLINOIS FED. AID PROJECT	CONTRACT NO. 76A73		

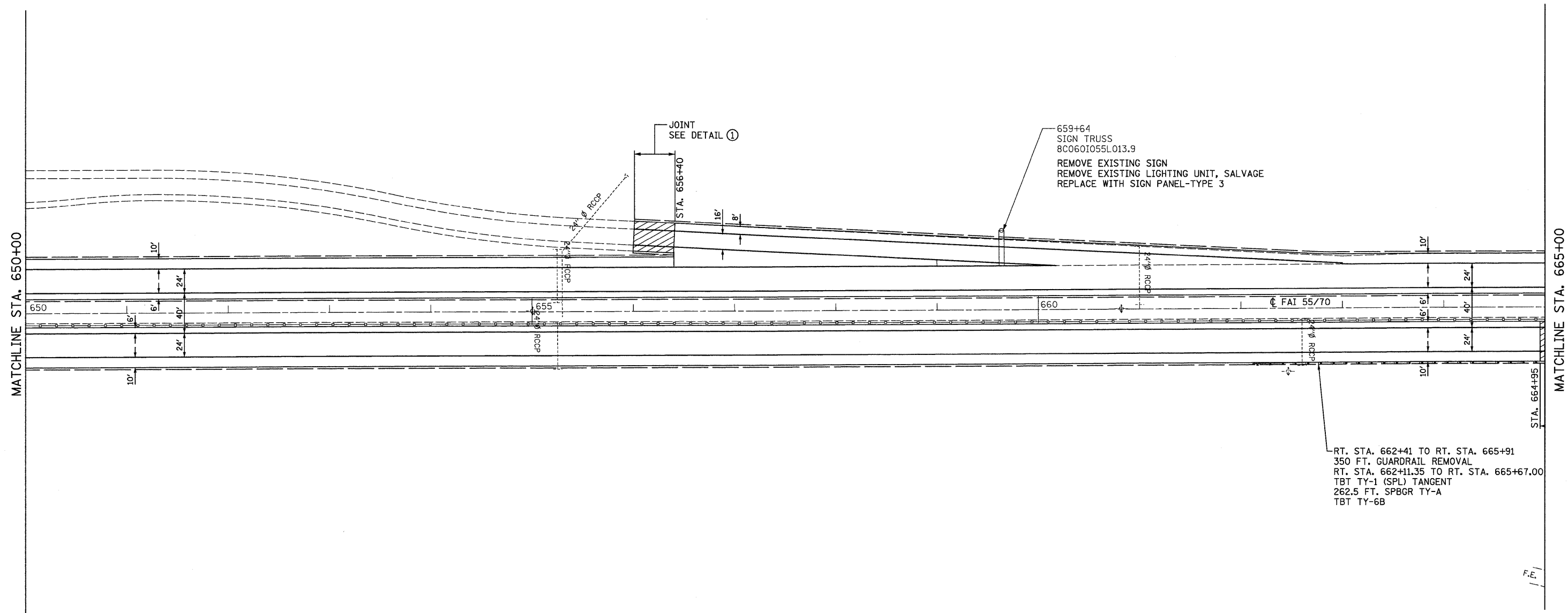

RT. STA. 662+41 TO RT. STA. 665+91  
 350 FT. GUARDRAIL REMOVAL  
 RT. STA. 662+11.35 TO RT. STA. 665+67.00  
 TBT TY-1 (SPL) TANGENT  
 262.5 FT. SPBGR TY-A  
 TBT TY-6B

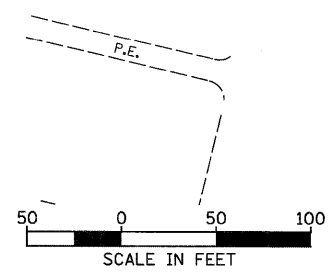

FILE NAME = ...\\0876A73-sht-pln-07.dgn 	USER NAME = SJS	DESIGNED -	REVISED -	<b>STATE OF ILLINOIS          DEPARTMENT OF TRANSPORTATION</b>	<b>F.A.I. ROUTE 70          ROADWAY PLANS</b>		F.A.I. RTE. 70	SECTION	COUNTY MADISON	TOTAL SHEETS 150	SHEET NO. 28
	PLOT SCALE = 50.0000' / IN. PLOT DATE = 06/12/2009 09:18:55	DRAWN - CHECKED - DATE -	REVISED - REVISED - REVISED -		SCALE: 1' = 50' SHEET NO. OF SHEETS STA. 650+00 TO STA. 665+00	FED. ROAD DIST. NO. ILLINOIS FED. AID PROJECT	CONTRACT NO. T6A73				

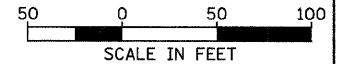
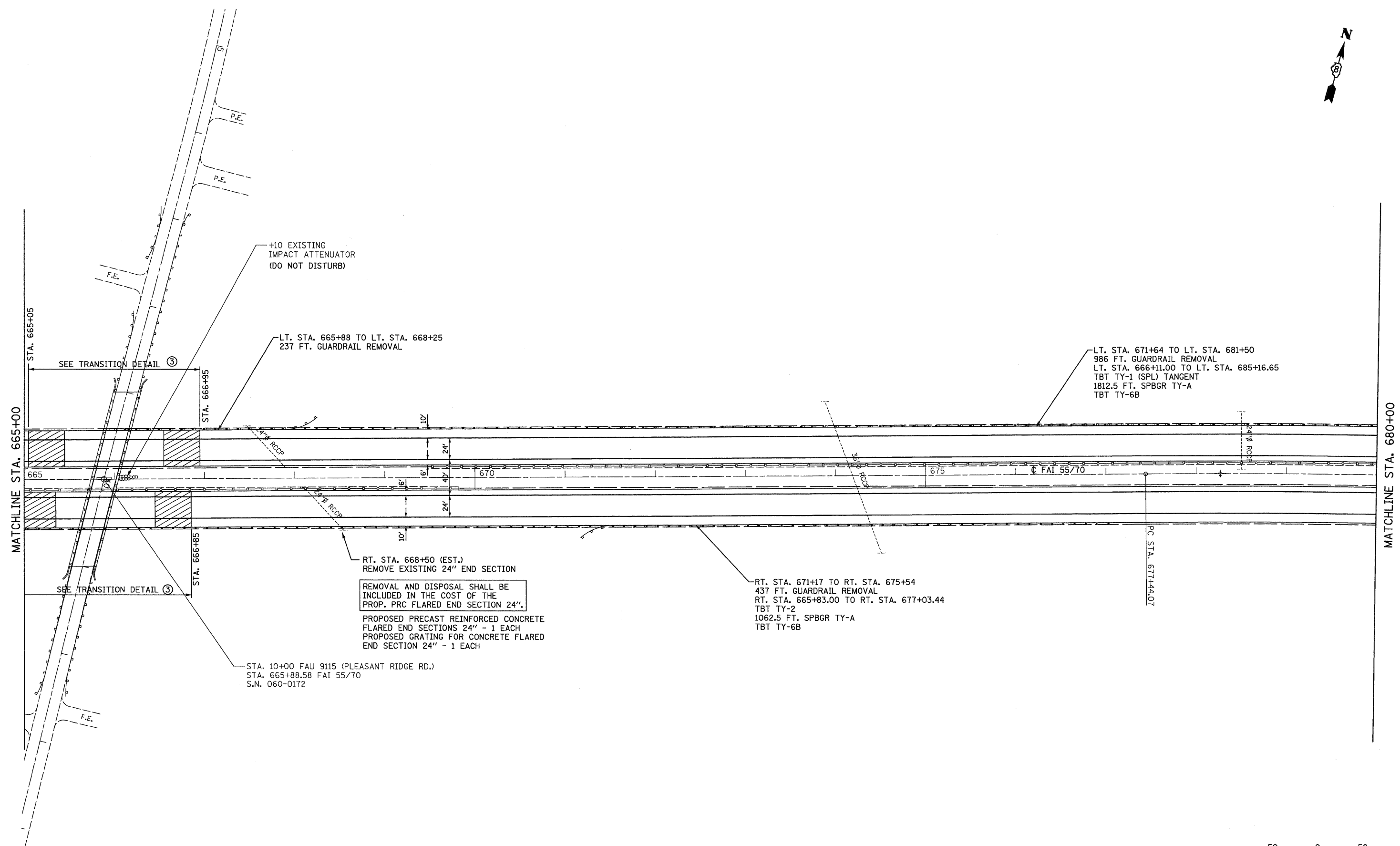

SCALE IN FEET  
 \* 60-(7,8,9,10)RS, 60-(8,9,10)BR

FILE NAME = ... \0676673-eh-t-plan08.dgn	USER NAME = SJS	DESIGNED -	REVISED -
Johnson, Depp & Quisenberry CONSULTING ENGINEERS Springfield, Illinois	PLOT SCALE = 50.0000' / IN.	DRAWN -	REVISED -
	PLOT DATE = 06/12/2009 09:19:09	CHECKED -	REVISED -
		DATE -	REVISED -

**STATE OF ILLINOIS  
 DEPARTMENT OF TRANSPORTATION**

**F.A.I. ROUTE 70  
 ROADWAY PLANS**

SCALE: 1' = 50'    SHEET NO.    OF    SHEETS    STA. 665+00    TO    STA. 680+00

F.A.I. RTE.	SECTION	COUNTY	TOTAL SHEETS	SHEET NO.
70	*	MADISON	150	29
FED. ROAD DIST. NO. ILLINOIS FED. AID PROJECT			CONTRACT NO. 76A73	

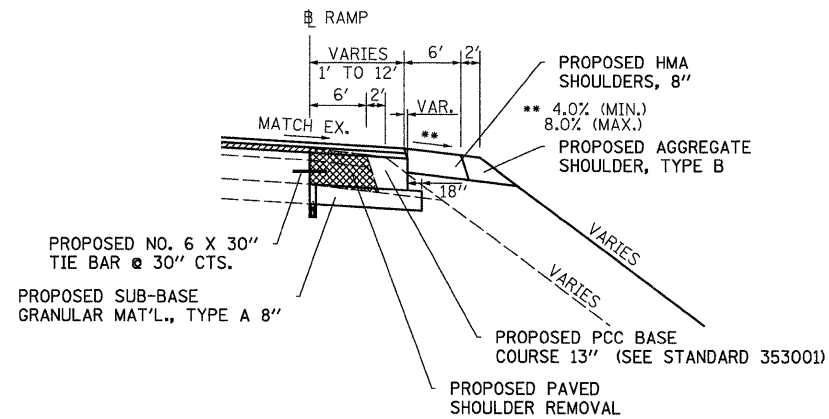

NOTES:  
 SEE TYPICAL SECTIONS FOR PROPOSED MILLING AND RESURFACING THICKNESSES AND OTHER ITEMS NOT SHOWN HERE.  
 PCC BASE CSE. 13" MAY VARY IN THICKNESS FROM STA. 16+61.91 TO STA. 20+44 RAMP "D" AND STA. 14+72.56 TO STA. 19+07 RAMP "H". WITHIN THE LIMITS OF THE WEIGH IN MOTION SLAB THE THICKNESS OF THE PCC BASE COURSE 13" WILL VARY.  
 AS DIRECTED BY THE ENGINEER. COST WILL BE INCLUDED IN PCC BASE COURSE 13".  
 PROPOSED HMA SHOULDERS, 8" VARIES IN WIDTH FROM 6' TO 10'. SEE PLAN SHEETS.

- SEQUENCE OF OPERATIONS:
1. REMOVE EXISTING PAVED SHOULDER AND MILL AS SHOWN.
  2. CONST PCC BASE COURSE TO THE LEVEL OF THE MILLED SURFACE. (PCC BASE COURSE THICKNESS AS SHOWN OR AS DIRECTED BY THE ENGINEER.)

**RAMP WIDENING DETAIL  
(IL 159 INTERCHANGE)**

RAMP D  
 1' RT. STA. 16+61.91 RAMP "D" TO 45' RT. STA. 727+37.21 FAI 55/70  
 RAMP H  
 45' LT. STA. 681+64.36 FAI 55/70 TO 1' RT. STA. 14+72.56 RAMP "H"

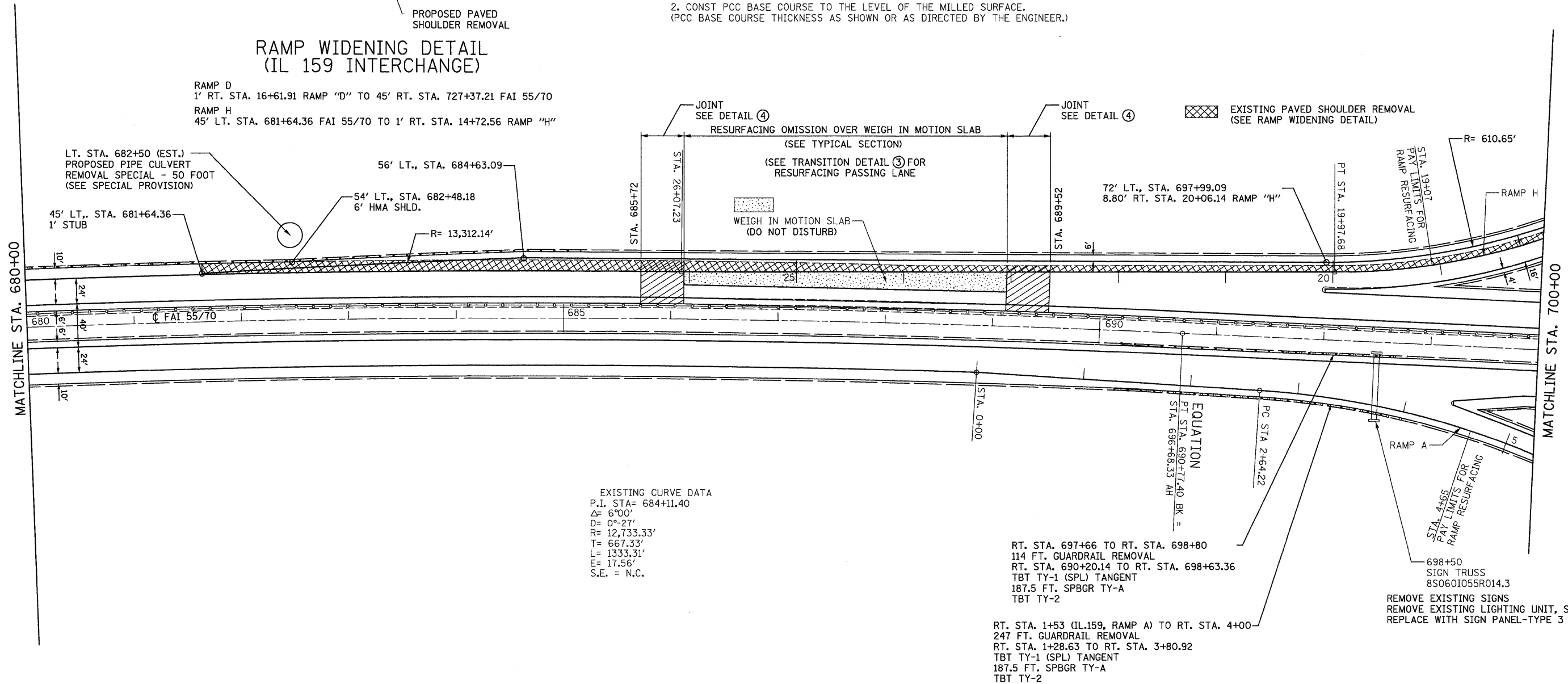

EXISTING CURVE DATA

P.I. STA=	684+11.40
Δ=	6°00'
D=	0°-27'
R=	12,733.33'
T=	667.33'
L=	1333.31'
E=	17.56'
S.E. =	N.C.

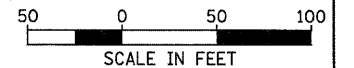

SCALE IN FEET

FILE NAME = ... \DB76A73-aht-plan09.dgn	USER NAME = SJS	DESIGNED -	REVISED -	<b>STATE OF ILLINOIS DEPARTMENT OF TRANSPORTATION</b>	<b>F.A.I. ROUTE 70 ROADWAY PLANS</b>	F.A.I. RTE. 70	SECTION .	COUNTY MADISON	TOTAL SHEETS 150	SHEET NO. 30		
Johnson, Depp & Qulsenberry CONSULTING ENGINEERS Springfield, Illinois	PLOT SCALE = 5/8" = 1' / IN.	DRAWN -	REVISED -			SCALE: 1" = 50'	SHEET NO. OF SHEETS	STA. 680+00 TO STA. 700+00	CONTRACT NO. 76A73			
	PLOT DATE = 06/12/2009 09:19:23	CHECKED -	REVISED -			FED. ROAD DIST. NO. ILLINOIS FED. AID PROJECT						
		DATE -	REVISED -									

EXISTING PAVED SHOULDER REMOVAL  
(SEE RAMP WIDENING DETAIL)

EXISTING CONCRETE PATCH  
(DO NOT DISTURB)

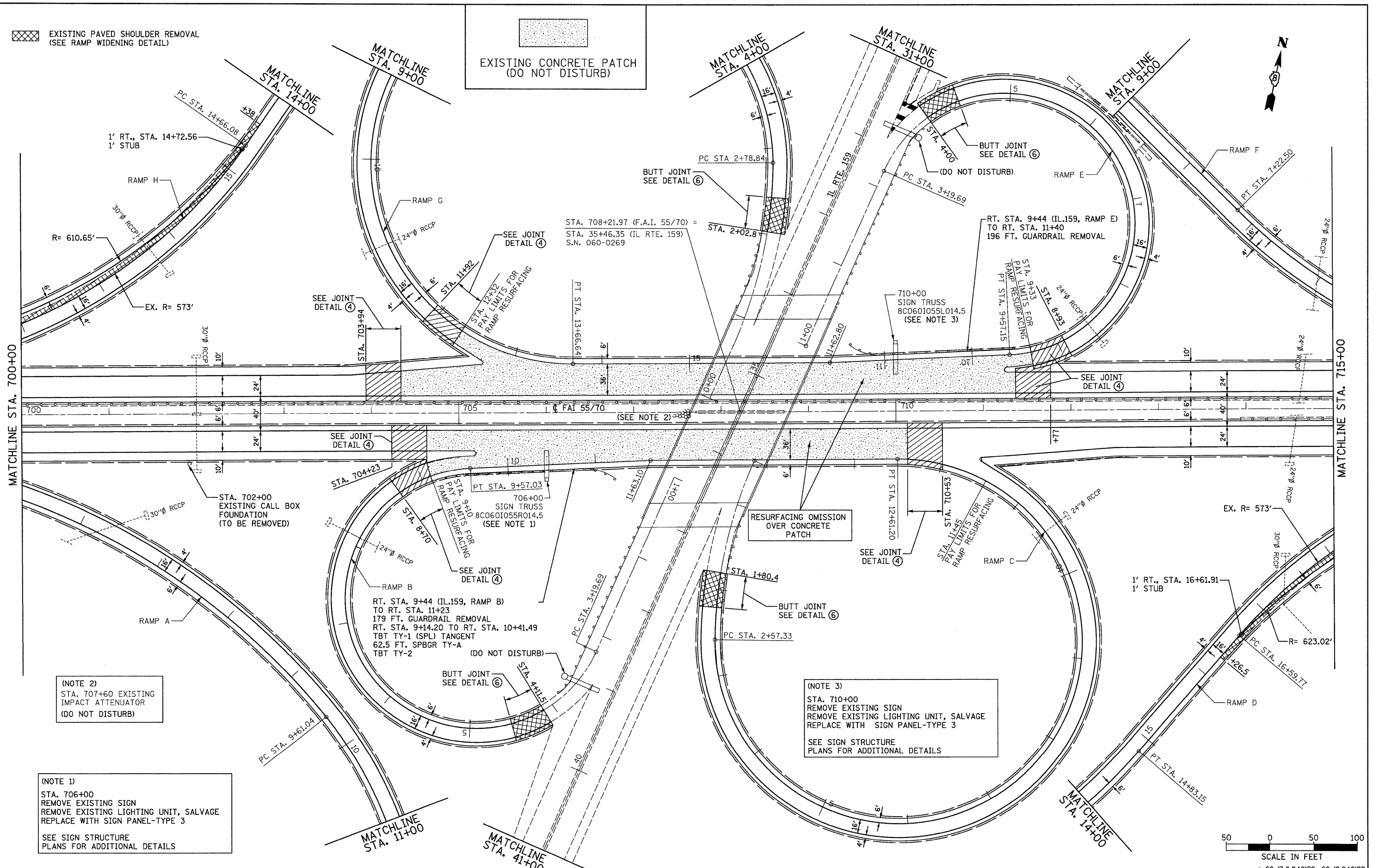

(NOTE 2)  
STA. 707+60 EXISTING  
IMPACT ATTENUATOR  
(DO NOT DISTURB)

(NOTE 1)  
STA. 706+00  
REMOVE EXISTING SIGN  
REMOVE EXISTING LIGHTING UNIT, SALVAGE  
REPLACE WITH SIGN PANEL-TYPE 3  
SEE SIGN STRUCTURE  
PLANS FOR ADDITIONAL DETAILS

(NOTE 3)  
STA. 710+00  
REMOVE EXISTING SIGN  
REMOVE EXISTING LIGHTING UNIT, SALVAGE  
REPLACE WITH SIGN PANEL-TYPE 3  
SEE SIGN STRUCTURE  
PLANS FOR ADDITIONAL DETAILS

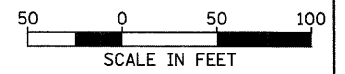

FILE NAME = ... \D876A73-shr-plan18.dgn	USER NAME = SJS	DESIGNED -	REVISED -	<b>STATE OF ILLINOIS DEPARTMENT OF TRANSPORTATION</b>	<b>F.A.I. ROUTE 70 ROADWAY PLANS</b>	F.A.I. RTE. 70	SECTION .	COUNTY MADISON	TOTAL SHEETS 150	SHEET NO. 31	
Johnson, Depp & Quisenberry CONSULTING ENGINEERS Springfield, Illinois	PLOT SCALE = 50.0000' / IN.	DRAWN -	REVISED -			SCALE: 1" = 50'	SHEET NO. OF SHEETS	STA. 700+00 TO STA. 715+00	FED. ROAD DIST. NO.	ILLINOIS FED. AID PROJECT	CONTRACT NO. 76A73
	PLOT DATE = 05/12/2009 09:19:39	CHECKED -	REVISED -								
		DATE -	REVISED -								

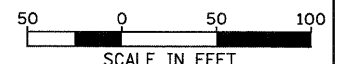
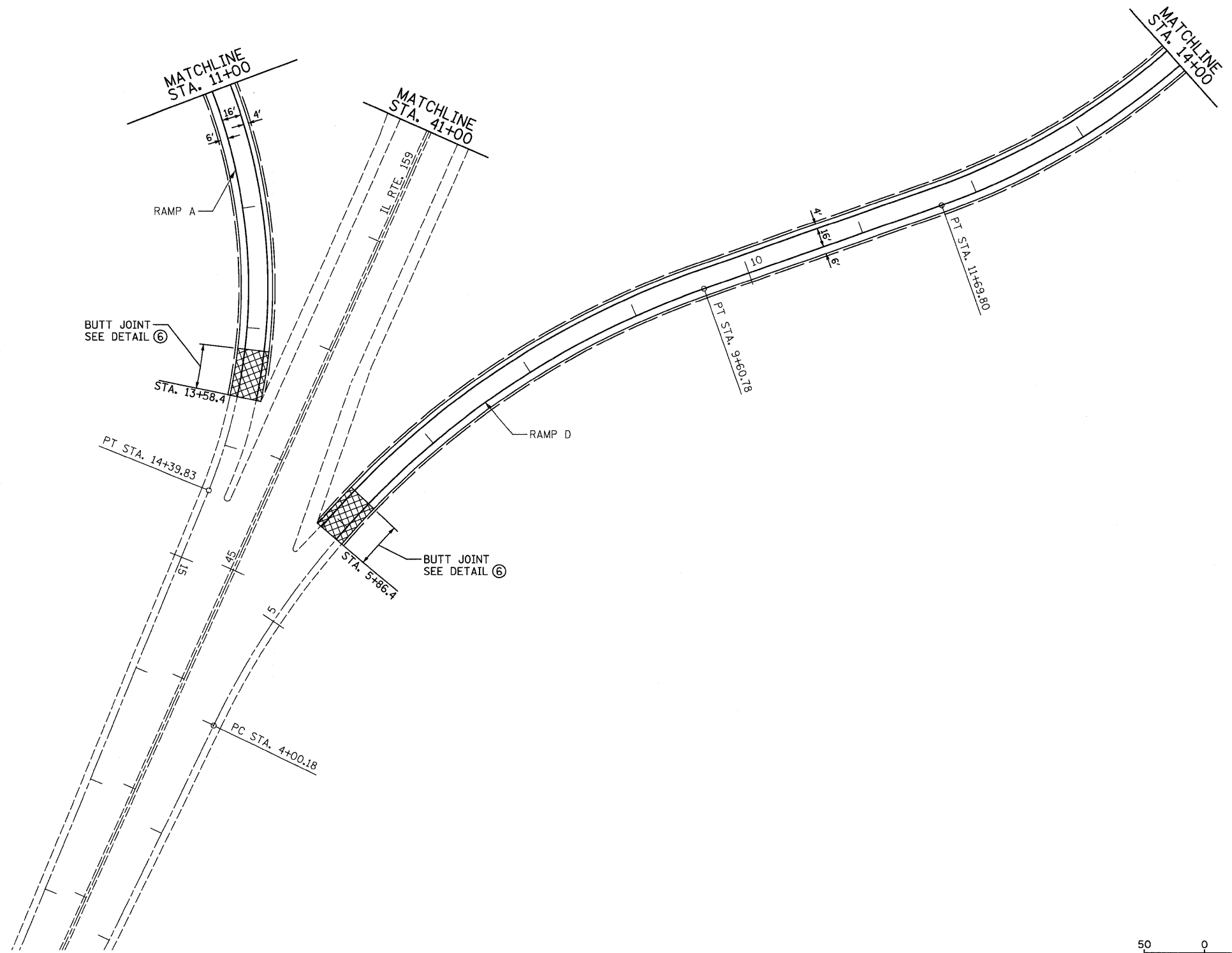

• 60-(7,8,9,10)RS, 60-(8,9,10)BR

FILE NAME = ... \0876A73-shr-plot10a.dgn 	USER NAME = SJS	DESIGNED -	REVISED -	<b>STATE OF ILLINOIS</b> <b>DEPARTMENT OF TRANSPORTATION</b>	<b>F.A.I. ROUTE 70</b> <b>ROADWAY PLANS</b>			F.A.I. RTE.	SECTION	COUNTY	TOTAL SHEETS	SHEET NO.
	PLOT SCALE = 50,0000' / IN.	CHECKED -	REVISED -		70	•	MADISON	150	32			
PLOT DATE = 06/12/2009 09:19:56	DATE -	REVISED -	REVISED -	SCALE: 1" = 50'	SHEET NO.	OF	SHEETS	STA.	TO STA.	FED. ROAD DIST. NO.	ILLINOIS FED. AID PROJECT	CONTRACT NO. 76A73



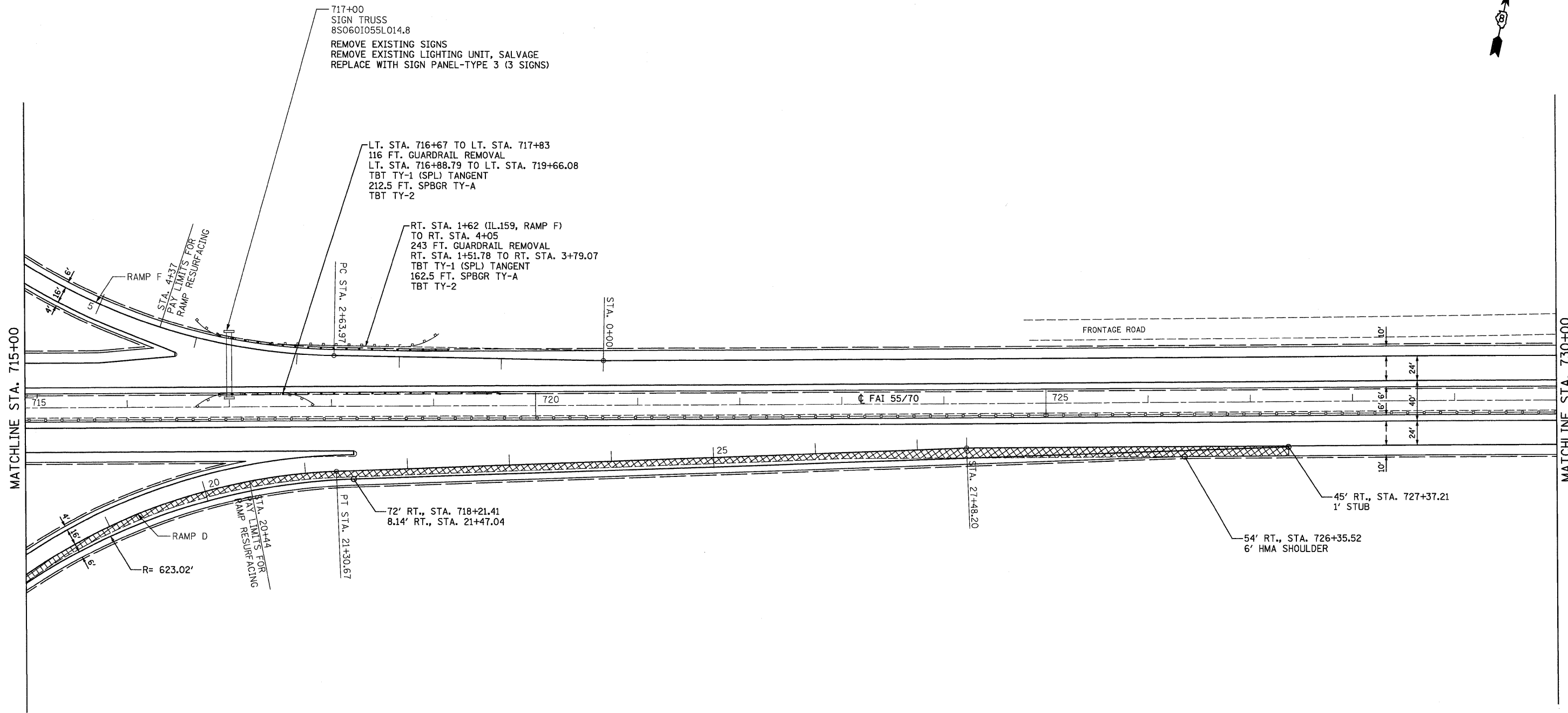

EXISTING PAVED SHOULDER REMOVAL  
 (SEE RAMP WIDENING DETAIL)

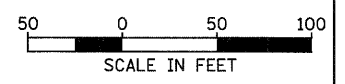

FILE NAME =	USER NAME = SJS	DESIGNED -	REVISED -
... \0876A73-sht-plan11.dgn		DRAWN -	REVISED -
Johnson, Depp & Qulsenberry CONSULTING ENGINEERS Springfield, Illinois	PLOT SCALE = 58.0000' / IN.	CHECKED -	REVISED -
	PLOT DATE = 06/12/2009 09:20:14	DATE -	REVISED -

**STATE OF ILLINOIS**  
**DEPARTMENT OF TRANSPORTATION**

**F.A.I. ROUTE 70**  
**ROADWAY PLANS**

SCALE: 1" = 50'    SHEET NO.    OF    SHEETS    STA. 715+00    TO    STA. 730+00

F.A.I. RTE.	SECTION	COUNTY	TOTAL SHEETS	SHEET NO.
70		MADISON	150	34
CONTRACT NO. 76A73				
FED. ROAD DIST. NO.		ILLINOIS FED. AID PROJECT		



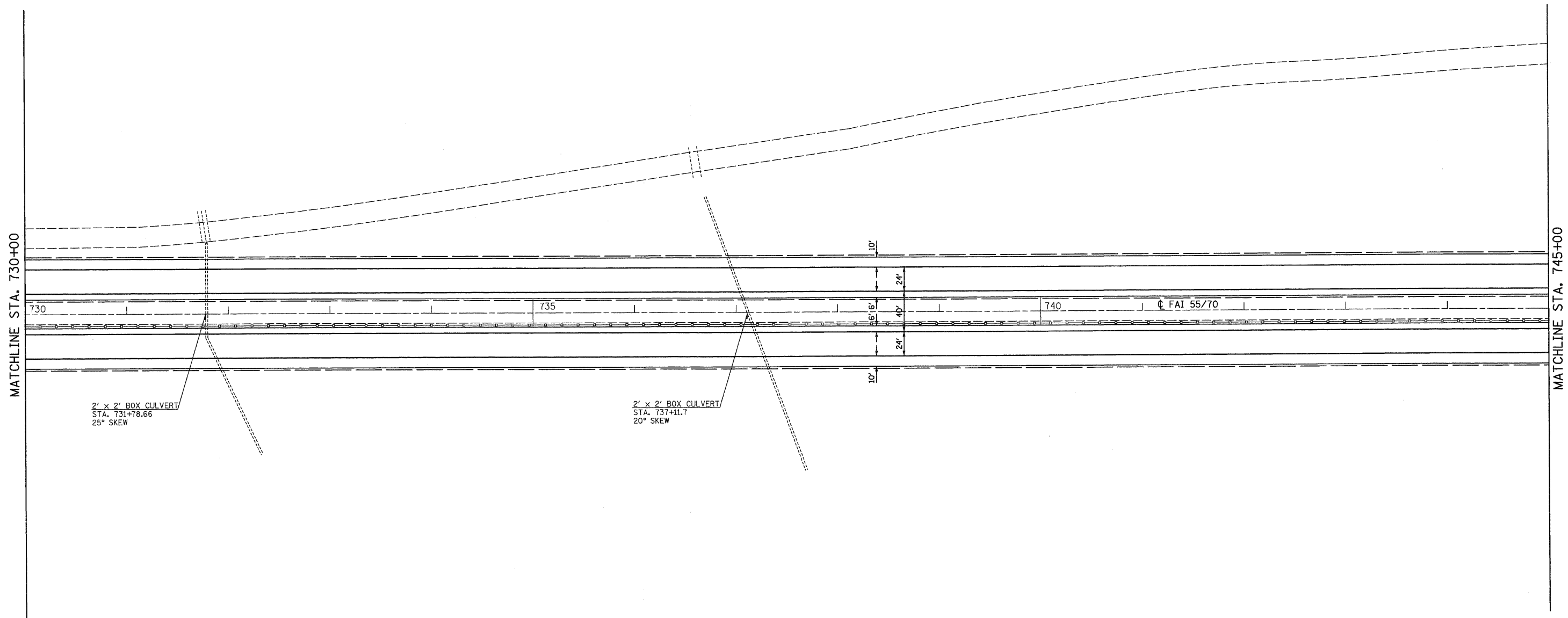

MATCHLINE STA. 730+00

MATCHLINE STA. 745+00

2' x 2' BOX CULVERT  
STA. 731+78.66  
25° SKEW

2' x 2' BOX CULVERT  
STA. 737+11.7  
20° SKEW

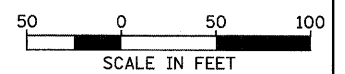

SCALE IN FEET  
• 60-(7,8,9,10)RS, 60-(8,9,10)BR

FILE NAME = ...\\0876A73-ahh-plan12.dgn 	USER NAME = SJS	DESIGNED -	REVISED -	<b>STATE OF ILLINOIS</b> <b>DEPARTMENT OF TRANSPORTATION</b>	<b>F.A.I. ROUTE 70</b> <b>ROADWAY PLANS</b>			F.A.I. RTE. 70	SECTION •	COUNTY MADISON	TOTAL SHEETS 150	SHEET NO. 35
	PLOT SCALE = 50.0000' / IN. PLOT DATE = 06/12/2009 09:20:27	DRAWN - CHECKED - DATE -	REVISED - REVISED - REVISED -		SCALE: 1' = 50' SHEET NO. OF SHEETS STA. 730+00 TO STA. 745+00	FED. ROAD DIST. NO. ILLINOIS FED. AID PROJECT	CONTRACT NO. 76A73					

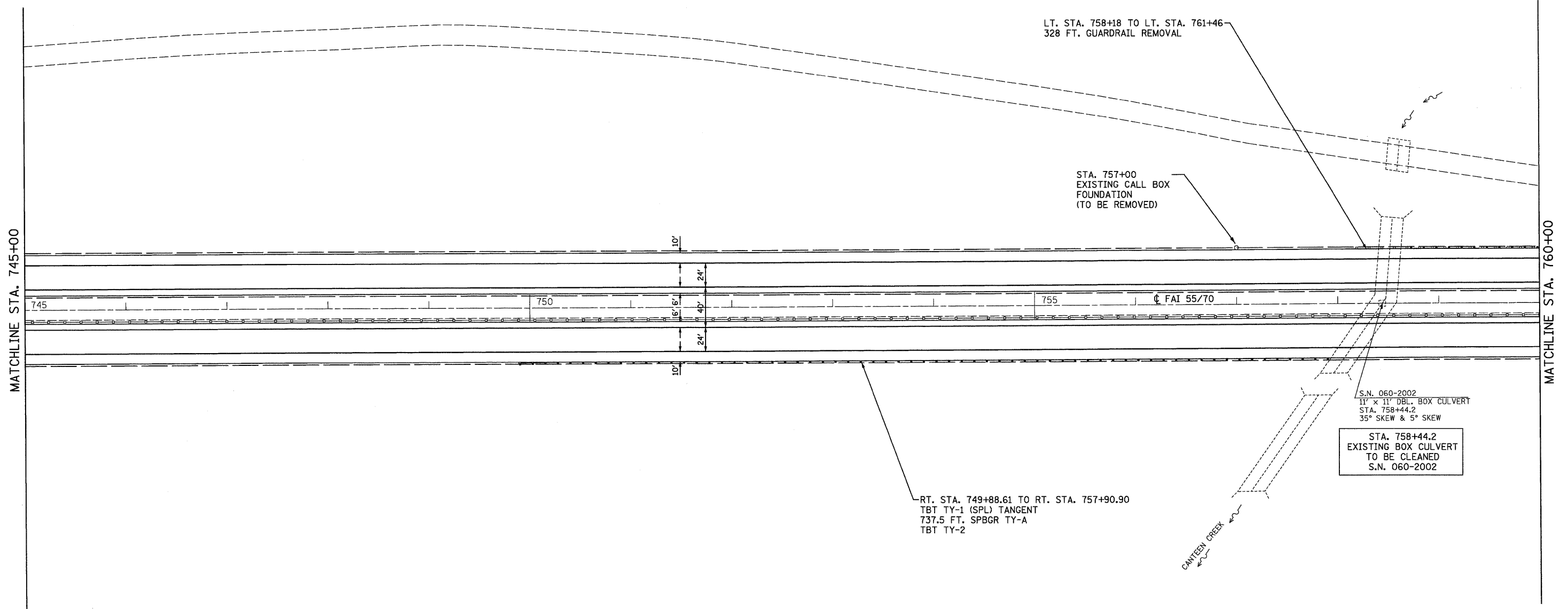

MATCHLINE STA. 745+00

MATCHLINE STA. 760+00

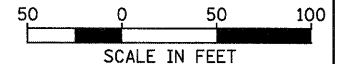

SCALE IN FEET

FILE NAME = ...10676A73-eh-t-plan13.dgn	USER NAME = SJS	DESIGNED -	REVISED -
 Johnson, Depp & Quisenberry CONSULTING ENGINEERS Springfield, Illinois	PLOT SCALE = 50.0000' / IN.	DRAWN -	REVISED -
	PLOT DATE = 06/12/2009 09:20:40	CHECKED -	REVISED -
		DATE -	REVISED -

**STATE OF ILLINOIS  
DEPARTMENT OF TRANSPORTATION**

<b>F.A.I. ROUTE 70 ROADWAY PLANS</b>	
SCALE: 1" = 50'	SHEET NO. OF SHEETS STA. 745+00 TO STA. 760+00

F.A.I. RTE.	SECTION	COUNTY	TOTAL SHEETS	SHEET NO.
70	*	MADISON	150	36
FED. ROAD DIST. NO.		ILLINOIS FED. AID PROJECT		
CONTRACT NO. 76A73				

\* 60-(7,8,9,10)RS, 60-(8,9,10)BR



EXISTING CURVE DATA  
 P.I. STA= 771+46.85  
 $\Delta$ = 9°44'  
 D= 0°41'42.72"  
 R= 8242.20'  
 T= 701.77'  
 L= 1400.09'  
 E= 29.82'  
 S.E. = 2.0%  
 P.C. STA= 764+45.08  
 P.C.C. STA= 778+45.17  
 ATTAIN S.E. STA 763+95.1 TO STA 764+95.1  
 REMOVE S.E. STA 777+95.2 TO STA 778+95.2

LT. STA. 764+42 TO LT. STA. 769+50  
 508 FT. GUARDRAIL REMOVAL  
 LT. STA. 758+72.10 TO LT. STA. 771+86.89  
 TBT TY-1 (SPL) TANGENT  
 1250 FT. SPBGR TY-A  
 TBT TY-2

PC STA. 764+45.08

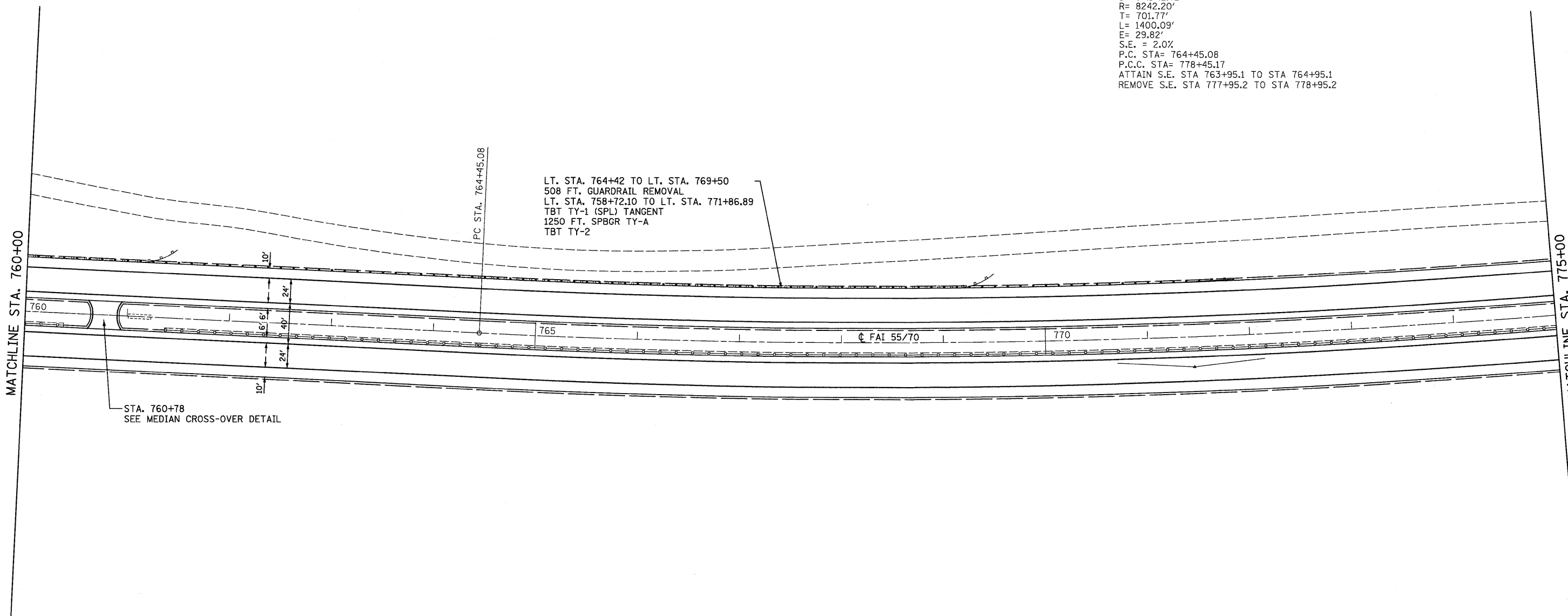

STA. 760+78  
 SEE MEDIAN CROSS-OVER DETAIL

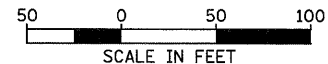

SCALE IN FEET  
 \* 60-(7,8,9,10)RS, 60-(8,9,10)BR

FILE NAME = ...\\0876673-eh-t-plan14.dgn	USER NAME = SJS	DESIGNED -	REVISED -
Johnson, Depp & Oulsenberry CONSULTING ENGINEERS Springfield, Illinois	PLOT SCALE = 50.0000' / IN.	DRAWN -	REVISED -
	PLOT DATE = 08/12/2009 09:20:52	CHECKED -	REVISED -
		DATE -	REVISED -

STATE OF ILLINOIS  
 DEPARTMENT OF TRANSPORTATION

F.A.I. ROUTE 70  
 ROADWAY PLANS

SCALE: 1" = 50' SHEET NO. OF SHEETS STA. 760+00 TO STA. 775+00

F.A.I. RTE.	SECTION	COUNTY	TOTAL SHEETS	SHEET NO.
70	*	MADISON	150	37
FED. ROAD DIST. NO. ILLINOIS FED. AID PROJECT			CONTRACT NO. 76A73	



EXISTING CURVE DATA  
 P.I. STA= 784+78.60  
 $\Delta$ = 2°32'  
 D= 0°12'  
 R= 28,647.88'  
 T= 633.43'  
 L= 1266.67'  
 E= 6.99'  
 S.E. RUN= N.C.  
 P.C.C. STA= 778+45.17  
 P.T. STA= 791+11.84

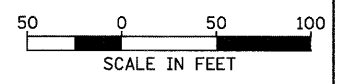
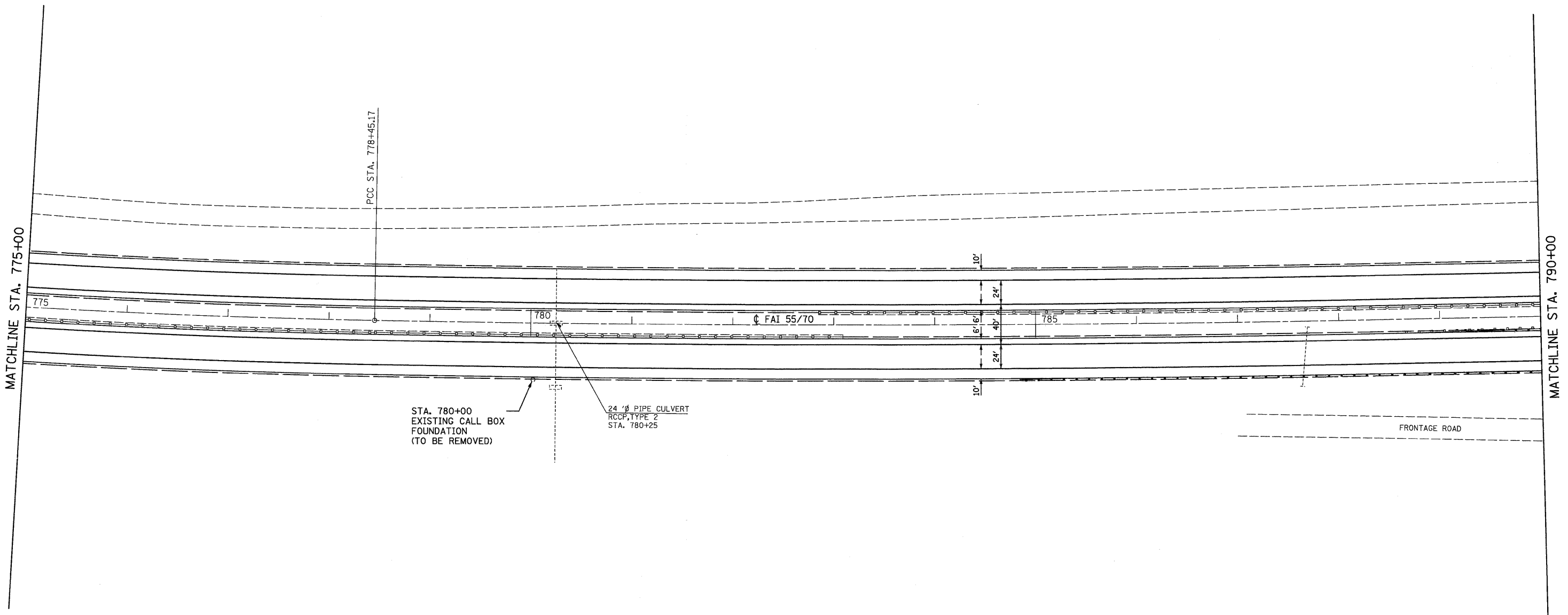

\* 60-(7,8,9,10)RS, 60-(8,9,10)BR

FILE NAME = ... \0878673-ah-plot15.dgn	USER NAME = SJS	DESIGNED -	REVISED -
Johnson, Depp & Quisenberry CONSULTING ENGINEERS Springfield, Illinois	PLOT SCALE = 50.0000' / IN.	DRAWN -	REVISED -
	PLOT DATE = 06/12/2009 09:21:06	CHECKED -	REVISED -
		DATE -	REVISED -

**STATE OF ILLINOIS  
 DEPARTMENT OF TRANSPORTATION**

**F.A.I. ROUTE 70  
 ROADWAY PLANS**

SCALE: 1" = 50' SHEET NO. OF SHEETS STA. 775+00 TO STA. 790+00

F.A.I. RTE.	SECTION	COUNTY	TOTAL SHEETS	SHEET NO.
70	*	MADISON	150	38
FED. ROAD DIST. NO. ILLINOIS FED. AID PROJECT			CONTRACT NO. 76A73	

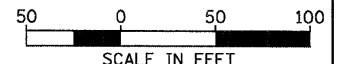
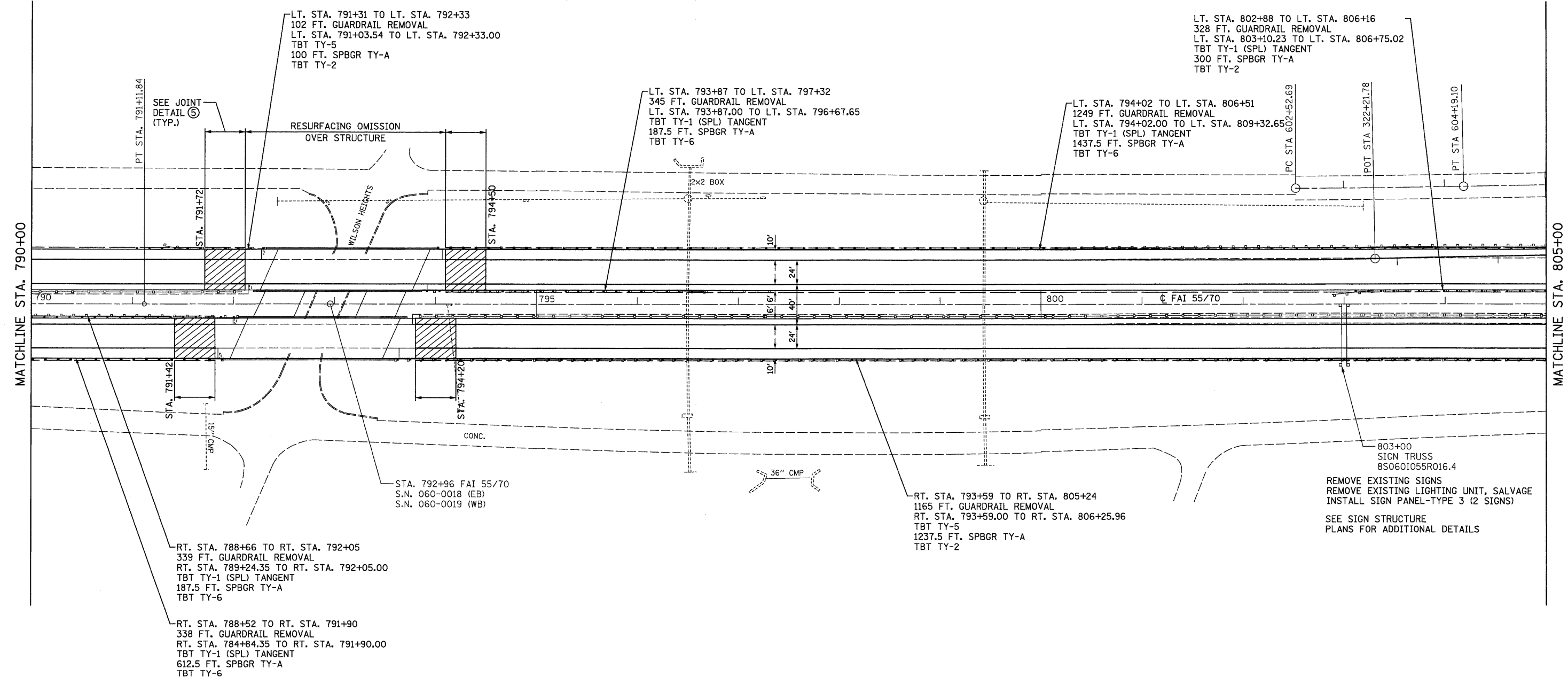
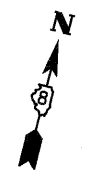

FILE NAME = ...\\0876A73-sht-plan16.dgn 	USER NAME = SJS	DESIGNED -	REVISED -	<b>STATE OF ILLINOIS</b> <b>DEPARTMENT OF TRANSPORTATION</b>	<b>F.A.I. ROUTE 70</b> <b>ROADWAY PLANS</b>		F.A.I. RTE. 70	SECTION	COUNTY MADISON	TOTAL SHEETS 150	SHEET NO. 39
	PLOT SCALE = 50.0000' / IN. PLOT DATE = 08/12/2009 09:21:20	CHECKED -	REVISED -		DATE -	SCALE: 1' = 50'	SHEET NO. OF SHEETS	STA. 790+00 TO STA. 805+00	FED. ROAD DIST. NO.	ILLINOIS FED. AID PROJECT	CONTRACT NO. 76A73

60-(7,8,9,10)RS, 60-(8,9,10)BR

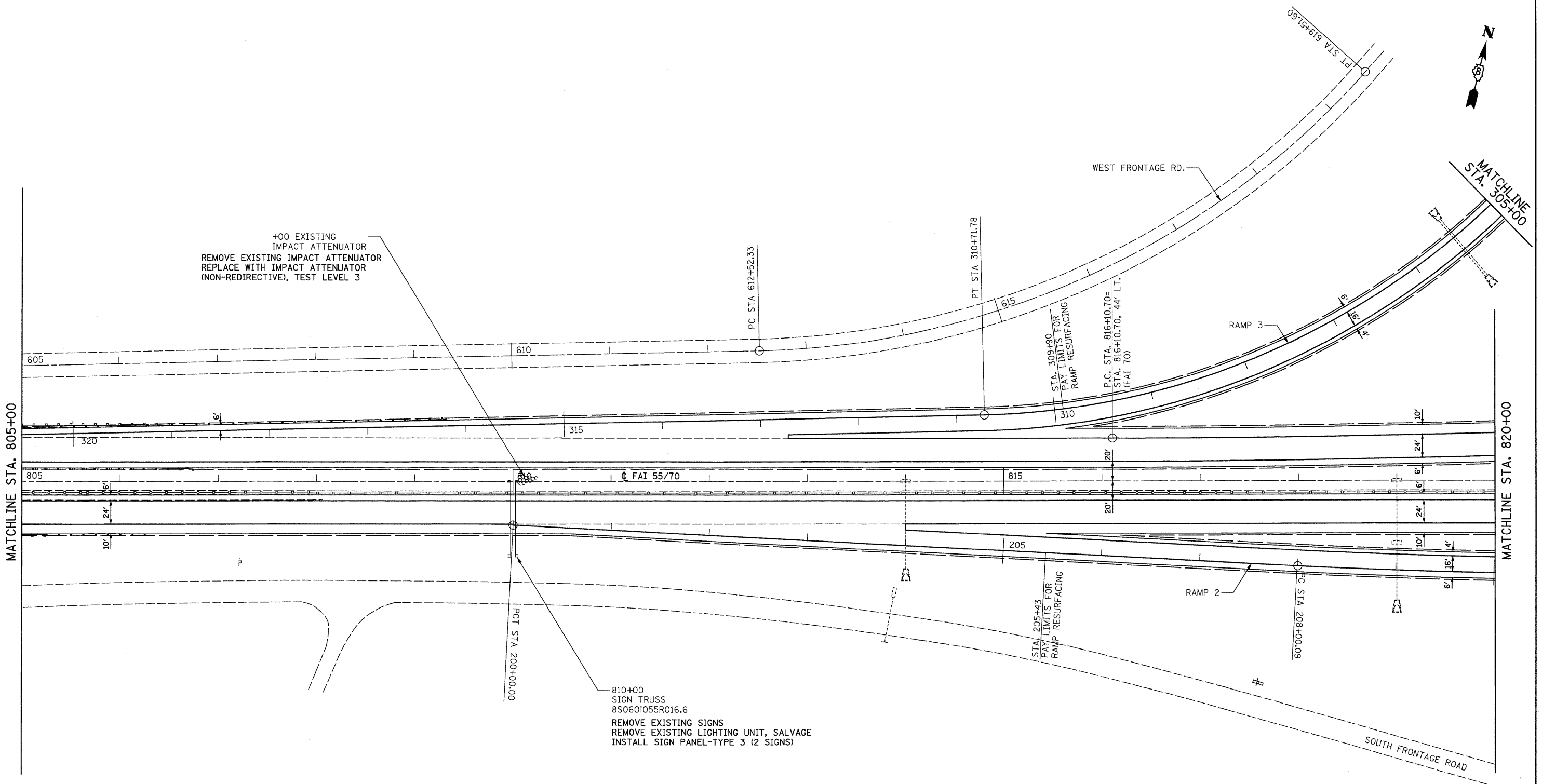

+00 EXISTING  
IMPACT ATTENUATOR  
REMOVE EXISTING IMPACT ATTENUATOR  
REPLACE WITH IMPACT ATTENUATOR  
(NON-REDIRECTIVE), TEST LEVEL 3

810+00  
SIGN TRUSS  
8S0601055R016.6  
REMOVE EXISTING SIGNS  
REMOVE EXISTING LIGHTING UNIT, SALVAGE  
INSTALL SIGN PANEL-TYPE 3 (2 SIGNS)

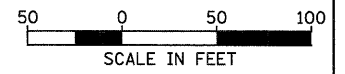

FILE NAME = ... \0876A73-sht-plan17.dgn	USER NAME = SJS	DESIGNED -	REVISED -
Johnson, Depp & Gilsenberry CONSULTING ENGINEERS Springfield, Illinois	PLOT SCALE = 50.0000' / IN.	DRAWN -	REVISED -
	PLOT DATE = 06/12/2009 09:21:34	CHECKED -	REVISED -
		DATE -	REVISED -

**STATE OF ILLINOIS  
DEPARTMENT OF TRANSPORTATION**

**F.A.I. ROUTE 70  
ROADWAY PLANS**

SCALE: 1" = 50'    SHEET NO.    OF    SHEETS    STA. 805+00    TO STA. 820+00

F.A.I. RTE. 70	SECTION •	COUNTY MADISON	TOTAL SHEETS 150	SHEET NO. 40
FED. ROAD DIST. NO.		ILLINOIS FED. AID PROJECT		
CONTRACT NO. 76A73				

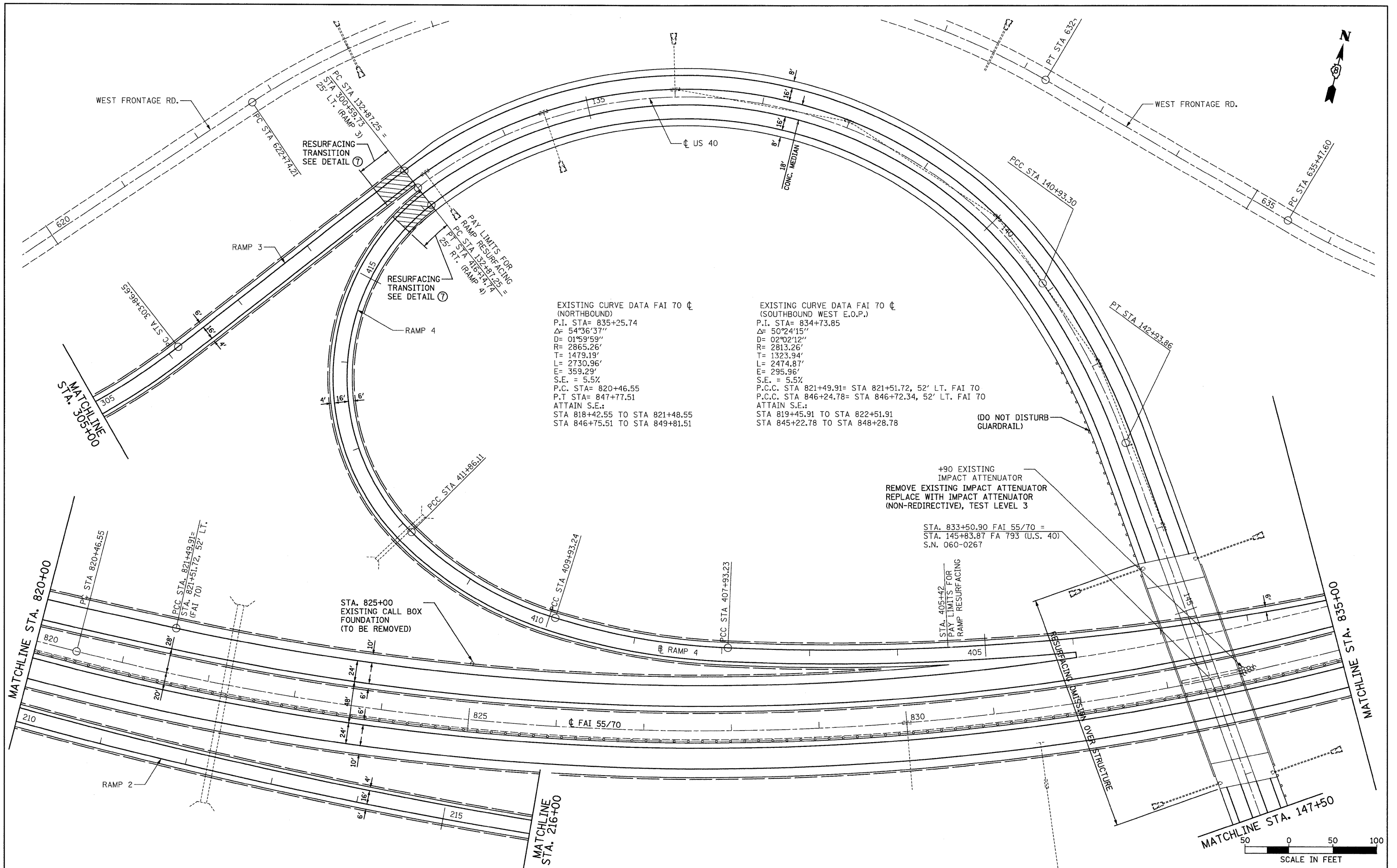

EXISTING CURVE DATA FAI 70  $\phi$   
(NORTHBOUND)  
 P.I. STA= 835+25.74  
 $\Delta = 54^{\circ}36'37''$   
 $D = 01^{\circ}59'59''$   
 $R = 2865.26'$   
 $T = 1479.19'$   
 $L = 2730.96'$   
 $E = 359.29'$   
 $S.E. = 5.5\%$   
 P.C. STA= 820+46.55  
 P.T. STA= 847+77.51  
 ATTAIN S.E.:  
 STA 818+42.55 TO STA 821+48.55  
 STA 846+75.51 TO STA 849+81.51

EXISTING CURVE DATA FAI 70  $\phi$   
(SOUTHBOUND WEST E.O.P.)  
 P.I. STA= 834+73.85  
 $\Delta = 50^{\circ}24'15''$   
 $D = 02^{\circ}02'12''$   
 $R = 2813.26'$   
 $T = 1323.94'$   
 $L = 2474.87'$   
 $E = 295.96'$   
 $S.E. = 5.5\%$   
 P.C.C. STA 821+49.91= STA 821+51.72, 52' LT. FAI 70  
 P.C.C. STA 846+24.78= STA 846+72.34, 52' LT. FAI 70  
 ATTAIN S.E.:  
 STA 819+45.91 TO STA 822+51.91  
 STA 845+22.78 TO STA 848+28.78

(DO NOT DISTURB  
GUARDRAIL)

+90 EXISTING  
IMPACT ATTENUATOR  
 REMOVE EXISTING IMPACT ATTENUATOR  
 REPLACE WITH IMPACT ATTENUATOR  
 (NON-REDIRECTIVE), TEST LEVEL 3

STA. 833+50.90 FAI 55/70 =  
 STA. 145+83.87 FA 793 (U.S. 40)  
 S.N. 060-0267

FILE NAME =  
 ...N0876A73-shr-plan18.dgn

**Johnson, Depp & Quisenberry**  
 CONSULTING ENGINEERS  
 Springfield, Illinois

USER NAME = SJS

DESIGNED -  
 DRAWN -  
 CHECKED -  
 PLOT DATE = 06/12/2009 09:21:48

REVISOR -  
 REVISIONS -  
 DATE -

**STATE OF ILLINOIS  
 DEPARTMENT OF TRANSPORTATION**

**F.A.I. ROUTE 70  
 ROADWAY PLANS**

SCALE: 1" = 50' SHEET NO. OF SHEETS STA. 820+00 TO STA. 835+00

F.A.I. RTE.	SECTION	COUNTY	TOTAL SHEETS	SHEET NO.
70	*	MADISON	150	41

CONTRACT NO. 76A73  
 FED. ROAD DIST. NO. ILLINOIS FED. AID PROJECT

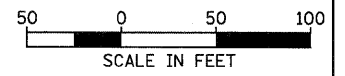
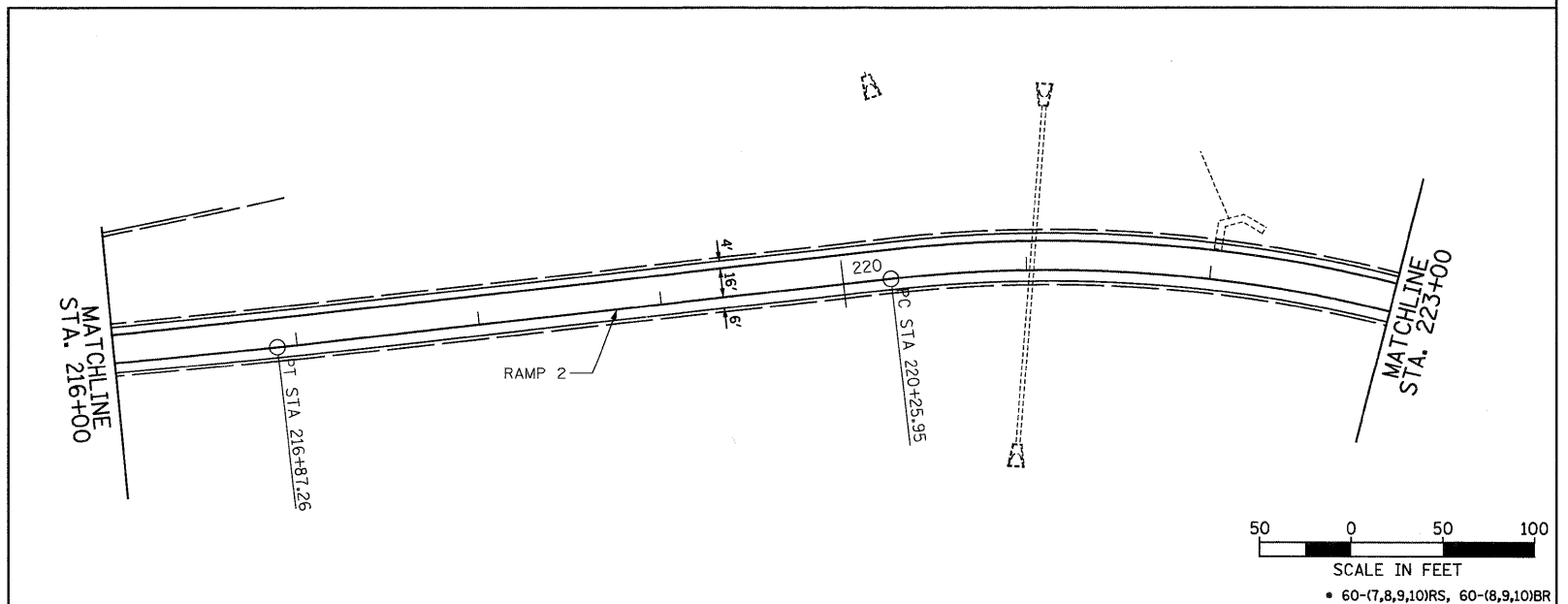
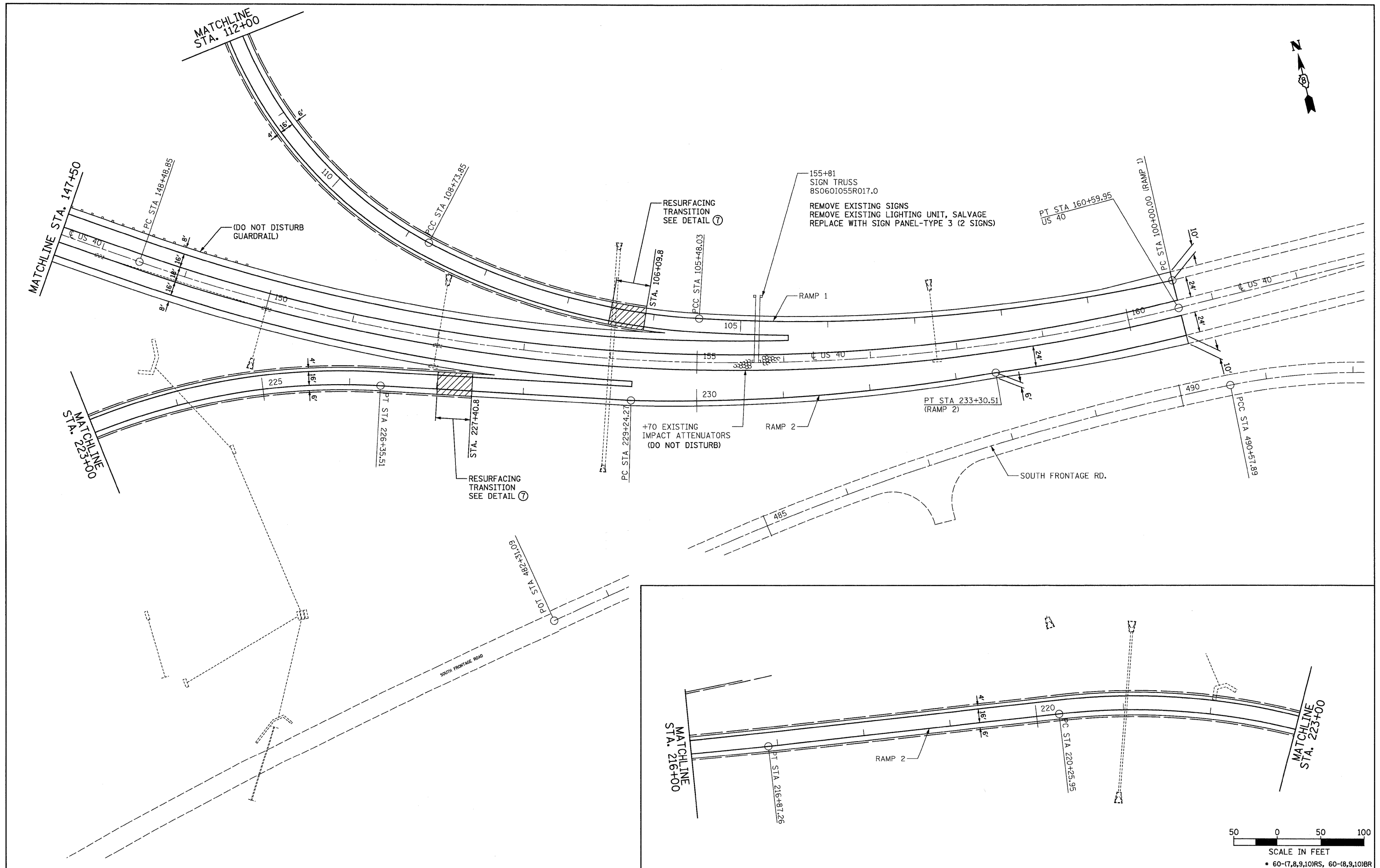

FILE NAME = ... \D876A73-shr-plan18a.dgn	USER NAME = SJS	DESIGNED -	REVISED -
Johnson, Depp & Quisenberry CONSULTING ENGINEERS Springfield, Illinois	PLOT SCALE = 50.0000' / IN.	DRAWN -	REVISED -
	PLOT DATE = 06/12/2009 09:22:06	CHECKED -	REVISED -
		DATE -	REVISED -

**STATE OF ILLINOIS  
DEPARTMENT OF TRANSPORTATION**

**F.A.I. ROUTE 70  
ROADWAY PLANS**

SCALE: 1' = 50'    SHEET NO.    OF    SHEETS    STA. 147+50    TO STA. 162+00

F.A.I. RTE.	SECTION	COUNTY	TOTAL SHEETS	SHEET NO.
70	.	MADISON	150	42
FED. ROAD DIST. NO.		ILLINOIS FED. AID PROJECT		
		CONTRACT NO. 76A73		

\* 60-(7,8,9,10)RS, 60-(8,9,10)BR



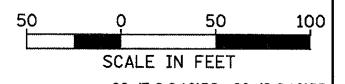
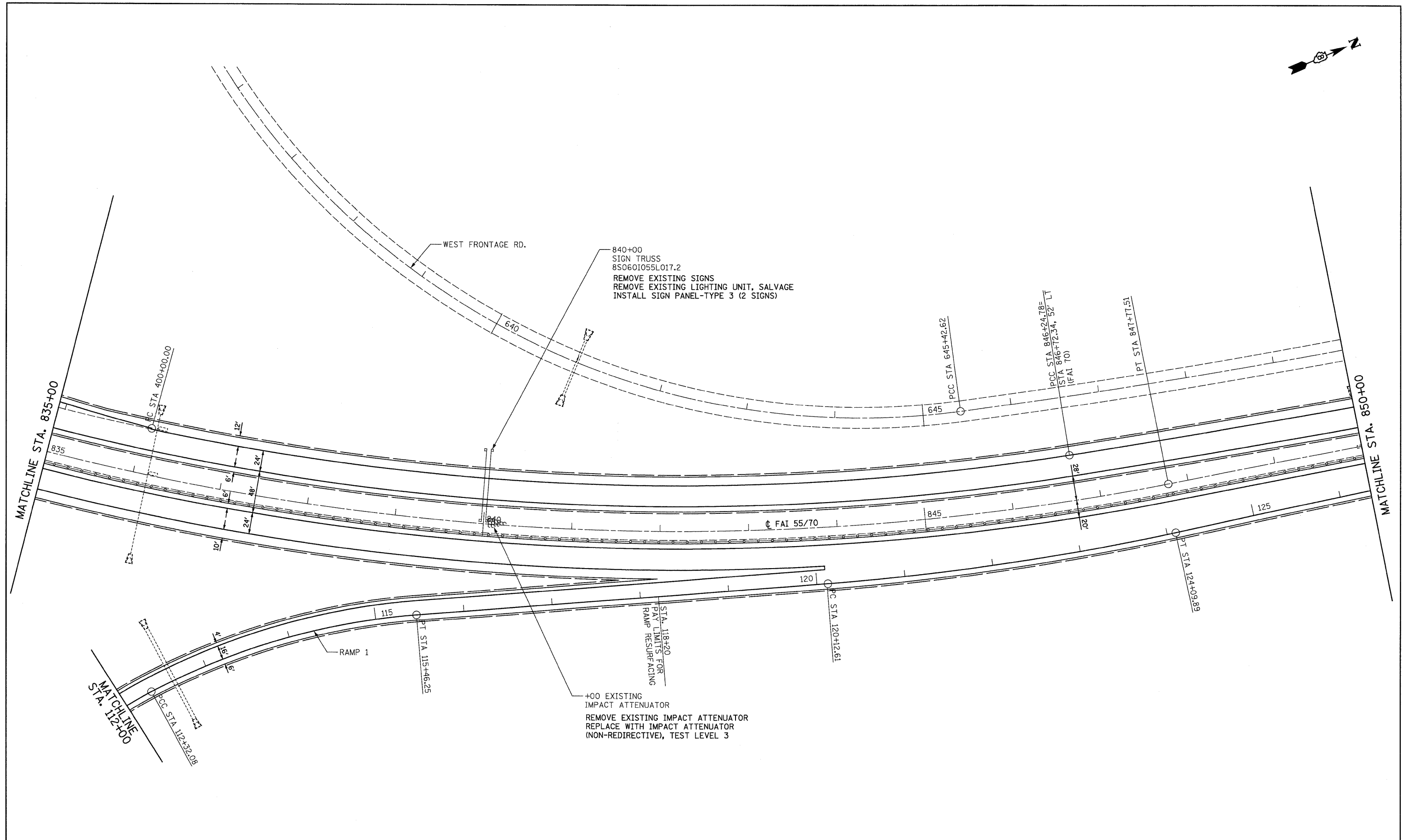
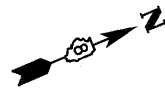

FILE NAME = ...N0876A73-shr-plan19.dgn	USER NAME = SJS	DESIGNED -	REVISED -	<b>STATE OF ILLINOIS DEPARTMENT OF TRANSPORTATION</b>	<b>F.A.I. ROUTE 70 ROADWAY PLANS</b>			F.A.I. RTE. 70	SECTION .	COUNTY MADISON	TOTAL SHEETS 150	SHEET NO. 43
Johnson, Depp & Quisenberry CONSULTING ENGINEERS Springfield, Illinois	PLOT SCALE = 50.0000' / IN.	CHECKED -	REVISED -		SCALE: 1" = 50'	SHEET NO.	OF	SHEETS	STA. 835+00	TO STA. 850+00	CONTRACT NO. T6A73	
	PLOT DATE = 06/12/2009 09:22:22	DATE -	REVISED -		FED. ROAD DIST. NO. ILLINOIS FED. AID PROJECT							

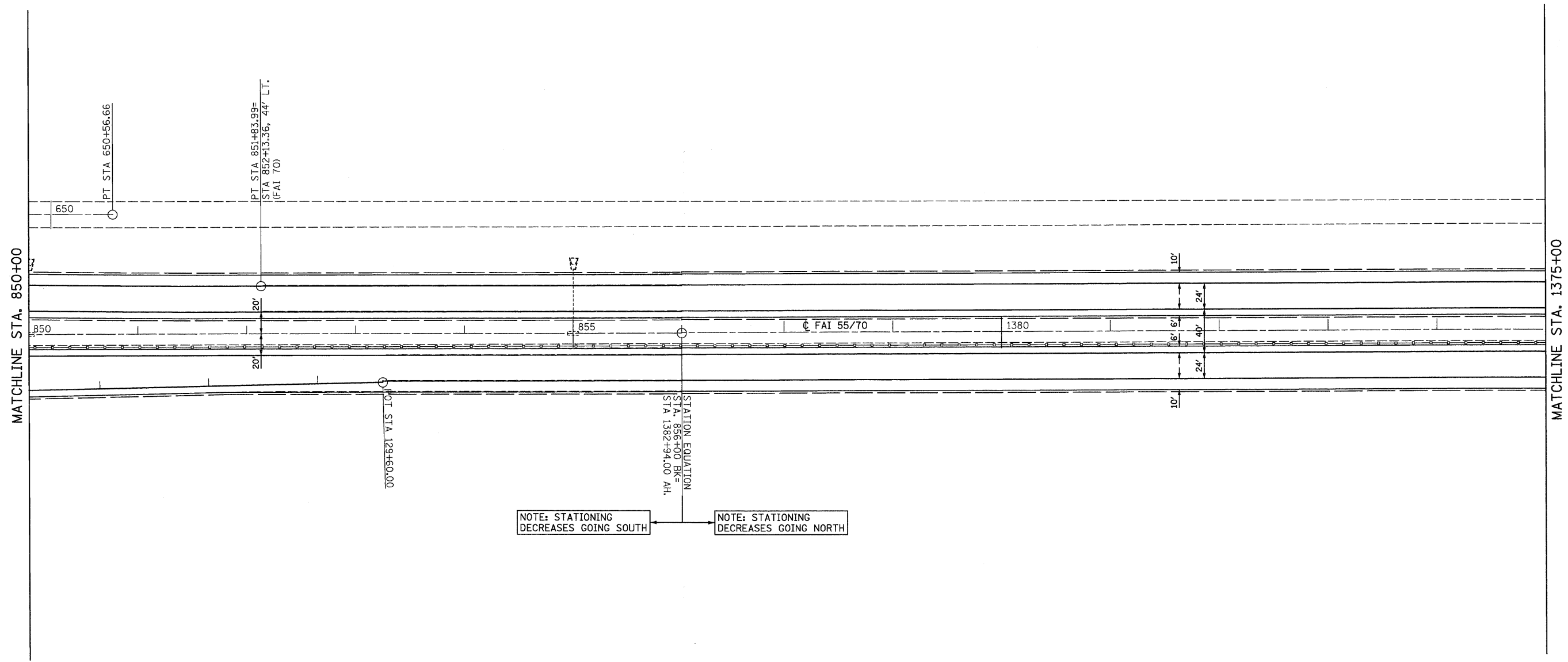

NOTE: STATIONING DECREASES GOING SOUTH

NOTE: STATIONING DECREASES GOING NORTH

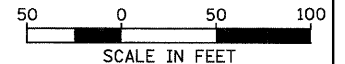

SCALE IN FEET

FILE NAME =  
... \0876A73-ah-plot20.dgn  
**JD Johnson, Depp & Quisenberry**  
CONSULTING ENGINEERS  
Springfield, Illinois

USER NAME = SJS  
PLOT SCALE = 50.0000' / IN.  
PLOT DATE = 06/12/2009 09:22:36

DESIGNED -  
DRAWN -  
CHECKED -  
DATE -

REVISED -  
REVISED -  
REVISED -  
REVISED -

**STATE OF ILLINOIS  
DEPARTMENT OF TRANSPORTATION**

**F.A.I. ROUTE 70  
ROADWAY PLANS**

SCALE: 1" = 50' SHEET NO. OF SHEETS STA. 850+00 TO STA. 1375+00

F.A.I. RTE.	SECTION	COUNTY	TOTAL SHEETS	SHEET NO.
70		MADISON	150	44
CONTRACT NO. 76A73				
FED. ROAD DIST. NO. ILLINOIS FED. AID PROJECT				

• 60-(7,8,9,10)RS, 60-(8,9,10)BR

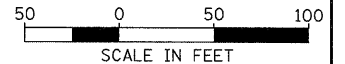
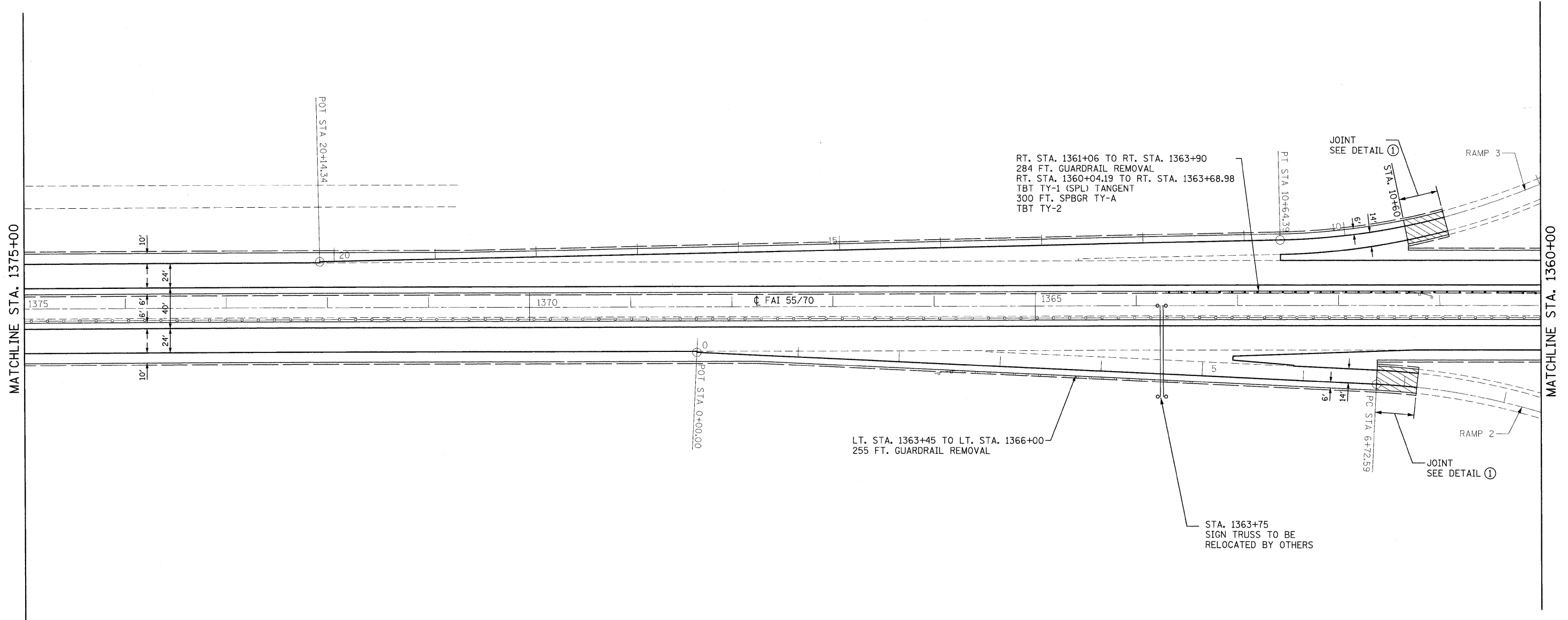

FILE NAME =  
 USER NAME = conoverpj  
 DESIGNED -  
 DRAWN -  
 CHECKED -  
 DATE -

76A73-sht-plan21.dgn  
 PLOT SCALE = 50,0000 ' / IN.  
 PLOT DATE = 8/10/2009

DESIGNED -  
 DRAWN -  
 CHECKED -  
 DATE -

REVISED -  
 REVISED -  
 REVISED -  
 REVISED -

**STATE OF ILLINOIS  
 DEPARTMENT OF TRANSPORTATION**

**F.A.I. ROUTE 70  
 ROADWAY PLANS**

SCALE: 1" = 50'    SHEET NO.    OF    SHEETS    STA. 1375+00    TO    STA. 1360+00

F.A.I. RTE.	SECTION	COUNTY	TOTAL SHEETS	SHEET NO.
70	*	MADISON	45	45
CONTRACT NO. 76A73				
ILLINOIS FED. AID PROJECT				

REV



MATCHLINE STA. 1360+00

MATCHLINE STA. 1345+00

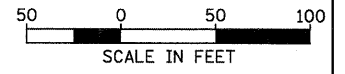
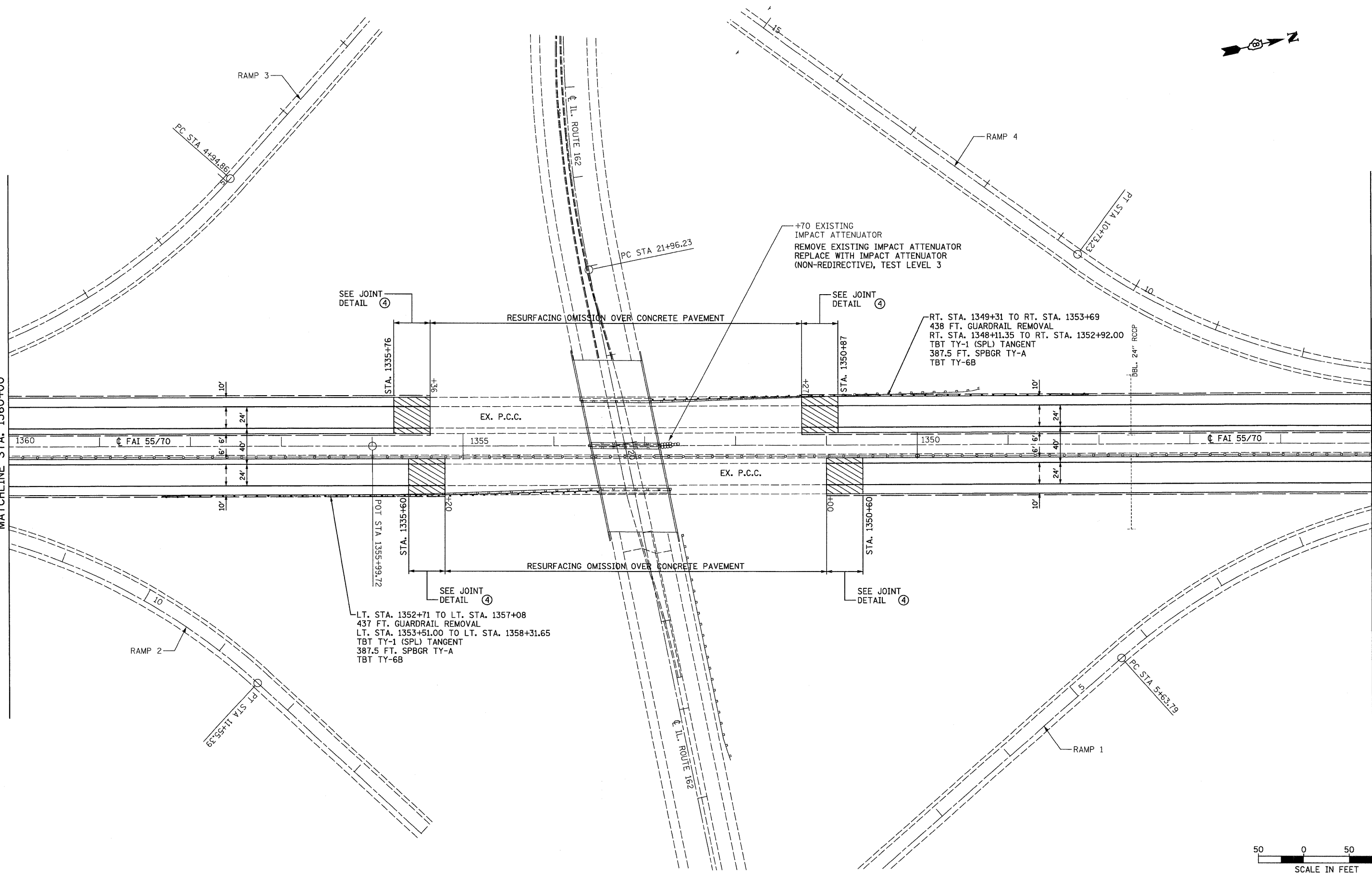

FILE NAME = ... \0878A73-ahh-plan22.dgn  
**Johnson, Depp & Quisenberry**  
 CONSULTING ENGINEERS  
 Springfield, Illinois

USER NAME = SJS  
 PLOT SCALE = 58.0000' / IN.  
 PLOT DATE = 06/12/2009 09:23:03

DESIGNED -  
 DRAWN -  
 CHECKED -  
 DATE -

REVISED -  
 REVISED -  
 REVISED -  
 REVISED -

**STATE OF ILLINOIS  
 DEPARTMENT OF TRANSPORTATION**

**F.A.I. ROUTE 70  
 ROADWAY PLANS**

SCALE: 1" = 50'    SHEET NO.    OF    SHEETS    STA. 1360+00    TO    STA. 1345+00

F.A.I. RTE.	SECTION	COUNTY	TOTAL SHEETS	SHEET NO.
70		MADISON	150	46
FED. ROAD DIST. NO. ILLINOIS FED. AID PROJECT			CONTRACT NO. 76A73	

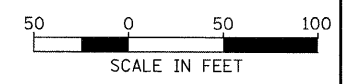
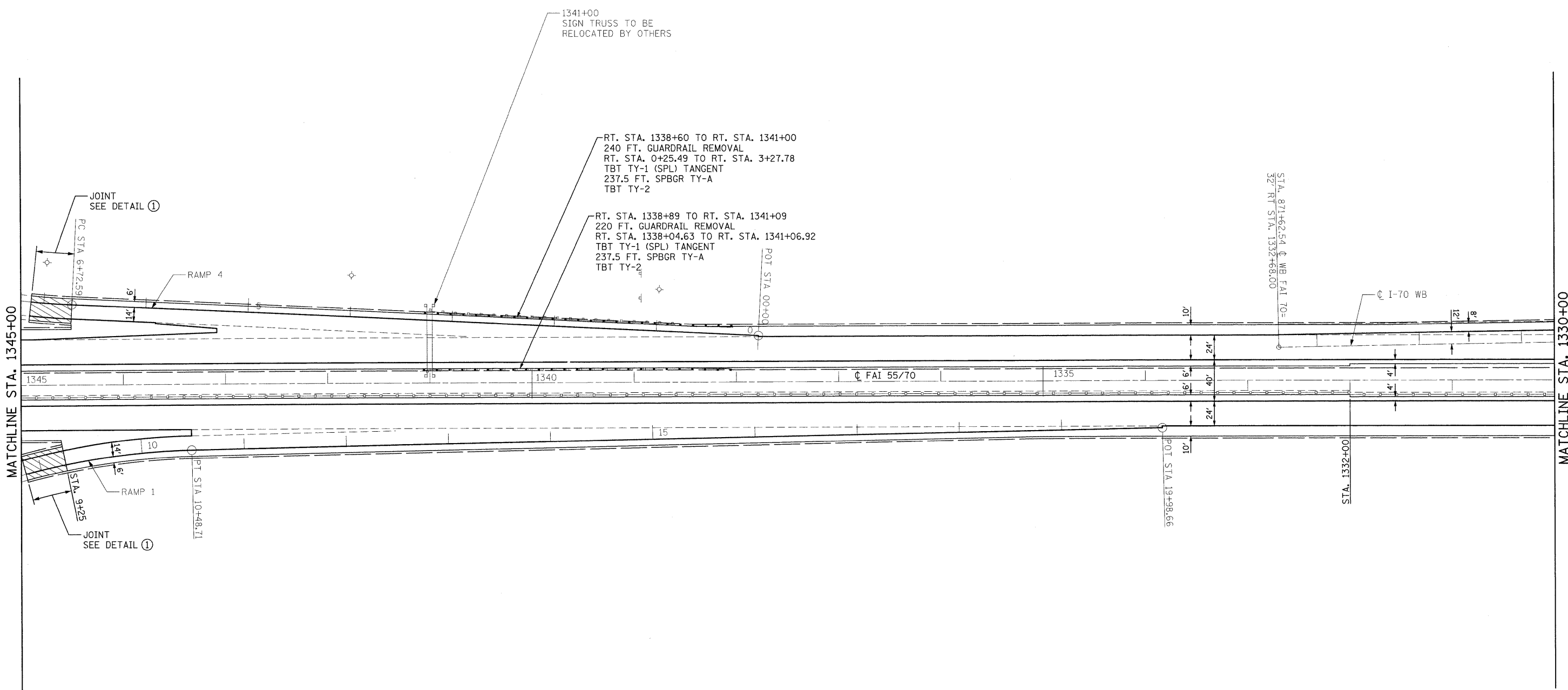

FILE NAME =	USER NAME = conoverpj	DESIGNED -	REVISED -
c:\pwork\work\PIDOT\CONOVERPJ\dms71073\0876A73-sht-plan23.dgn		DRAWN -	REVISED -
	PLOT SCALE = 50.0000' / IN.	CHECKED -	REVISED -
	PLOT DATE = 8/10/2009	DATE -	REVISED -

STATE OF ILLINOIS  
DEPARTMENT OF TRANSPORTATION

Rev.

F.A.I. ROUTE 70  
ROADWAY PLANS

SCALE: 1' = 50' SHEET NO. OF SHEETS STA. 1345+00 TO STA. 1330+00

F.A.I. RTE.	SECTION	COUNTY	TOTAL SHEETS	SHEET NO.
70	*	MADISON	47	47
FED. ROAD DIST. NO. ILLINOIS FED. AID PROJECT			CONTRACT NO. 76A73	

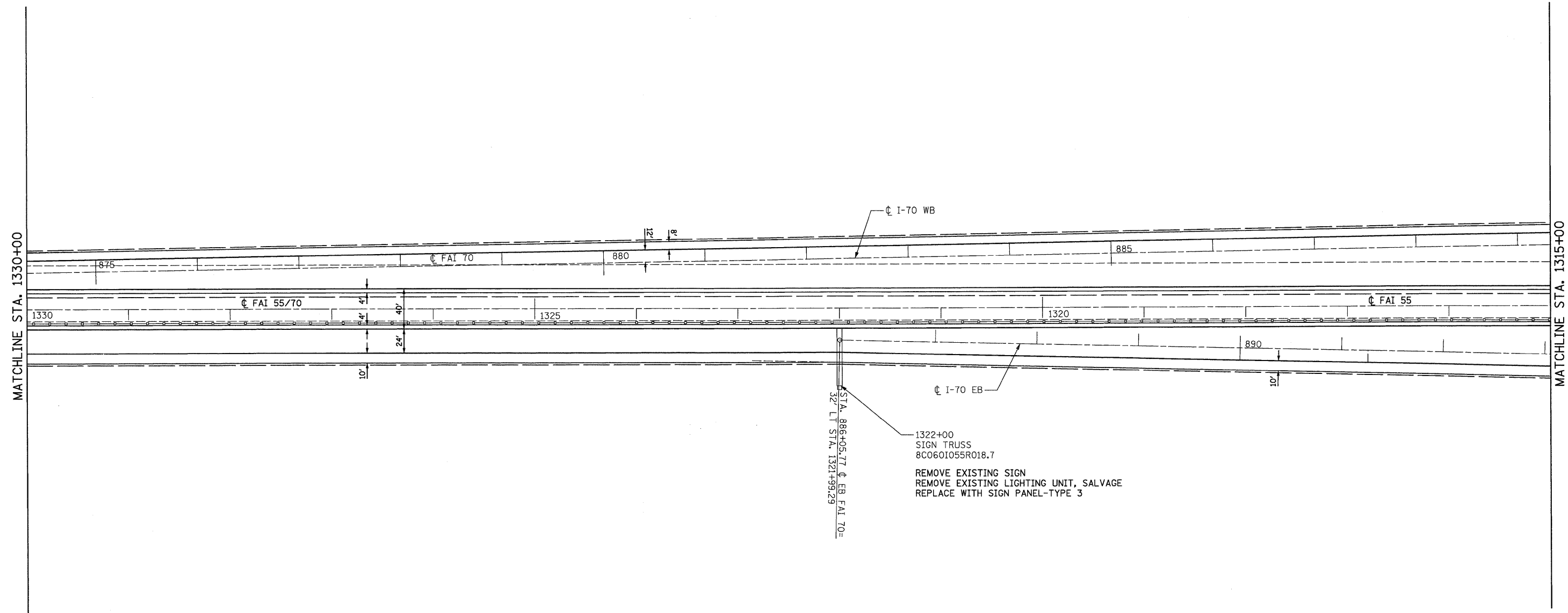

STA. 886+05.77  $\downarrow$  EB FAI 70=  
32' LT STA. 1321+99.29

1322+00  
SIGN TRUSS  
8C060I055R018.7  
REMOVE EXISTING SIGN  
REMOVE EXISTING LIGHTING UNIT, SALVAGE  
REPLACE WITH SIGN PANEL-TYPE 3

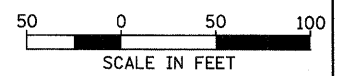

FILE NAME = ... \0876A73-ah-plot24.dgn	USER NAME = SJS	DESIGNED -	REVISED -
Johnson, Depp & Quisenberry CONSULTING ENGINEERS Springfield, Illinois	PLOT SCALE = 50.0000' / IN.	DRAWN -	REVISED -
PLOT DATE = 06/12/2009 09:23:30	DATE -	CHECKED -	REVISED -
		DATE -	REVISED -

STATE OF ILLINOIS  
DEPARTMENT OF TRANSPORTATION

F.A.I. ROUTE 70  
ROADWAY PLANS

SCALE: 1' = 50' SHEET NO. OF SHEETS STA. 1330+00 TO STA. 1315+00

F.A.I. RTE. 70	SECTION •	COUNTY MADISON	TOTAL SHEETS 150	SHEET NO. 48
FED. ROAD DIST. NO.		ILLINOIS FED. AID PROJECT		
		CONTRACT NO. 76A73		

• 60-(7,8,9,10)RS, 60-(8,9,10)BR

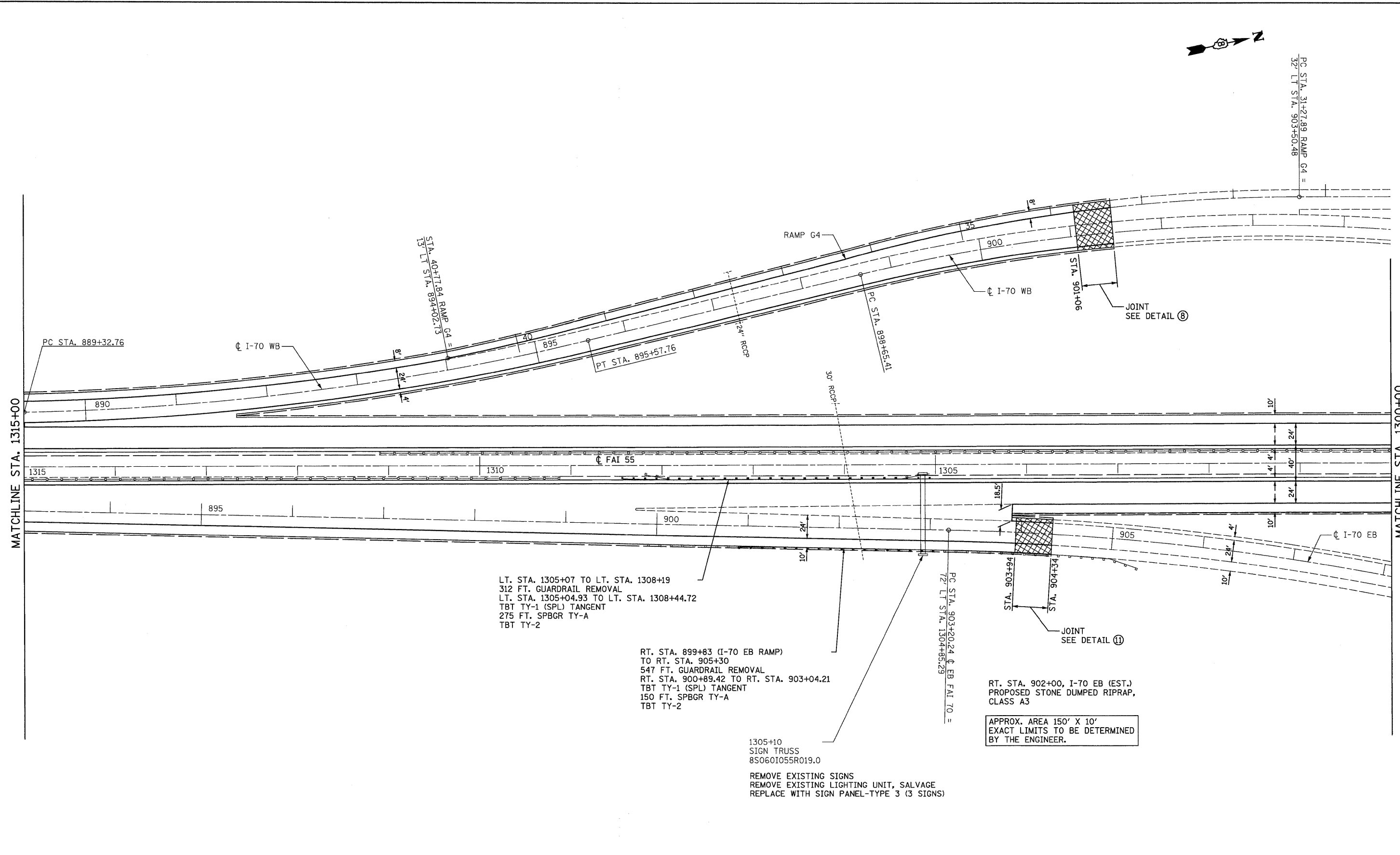

LT. STA. 1305+07 TO LT. STA. 1308+19  
 312 FT. GUARDRAIL REMOVAL  
 LT. STA. 1305+04.93 TO LT. STA. 1308+44.72  
 TBT TY-1 (SPL) TANGENT  
 275 FT. SPBGR TY-A  
 TBT TY-2

RT. STA. 899+83 (I-70 EB RAMP)  
 TO RT. STA. 905+30  
 547 FT. GUARDRAIL REMOVAL  
 RT. STA. 900+89.42 TO RT. STA. 903+04.21  
 TBT TY-1 (SPL) TANGENT  
 150 FT. SPBGR TY-A  
 TBT TY-2

1305+10  
 SIGN TRUSS  
 8S060I055R019.0  
 REMOVE EXISTING SIGNS  
 REMOVE EXISTING LIGHTING UNIT, SALVAGE  
 REPLACE WITH SIGN PANEL-TYPE 3 (3 SIGNS)

RT. STA. 902+00, I-70 EB (EST.)  
 PROPOSED STONE DUMPED RIPRAP,  
 CLASS A3

APPROX. AREA 150' X 10'  
 EXACT LIMITS TO BE DETERMINED  
 BY THE ENGINEER.

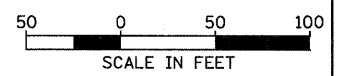

FILE NAME = ... \D876A73-shr-plot25.dgn	USER NAME = SJS	DESIGNED -	REVISED -
Johnson, Depp & Cuisenberry CONSULTING ENGINEERS Springfield, Illinois	PLOT SCALE = 50.0000' / IN.	DRAWN -	REVISED -
PLOT DATE = 06/12/2009 09:23:42	DATE -	CHECKED -	REVISED -
		DATE -	REVISED -

**STATE OF ILLINOIS  
 DEPARTMENT OF TRANSPORTATION**

**F.A.I. ROUTE 70  
 ROADWAY PLANS**

SCALE: 1" = 50'    SHEET NO.    OF    SHEETS    STA. 1315+00    TO    STA. 1300+00

F.A.I. RTE. 70	SECTION •	COUNTY MADISON	TOTAL SHEETS 150	SHEET NO. 49
FED. ROAD DIST. NO.		ILLINOIS FED. AID PROJECT		
CONTRACT NO. 76A73				

• 60-(7,8,9,10)RS, 60-(8,9,10)BR

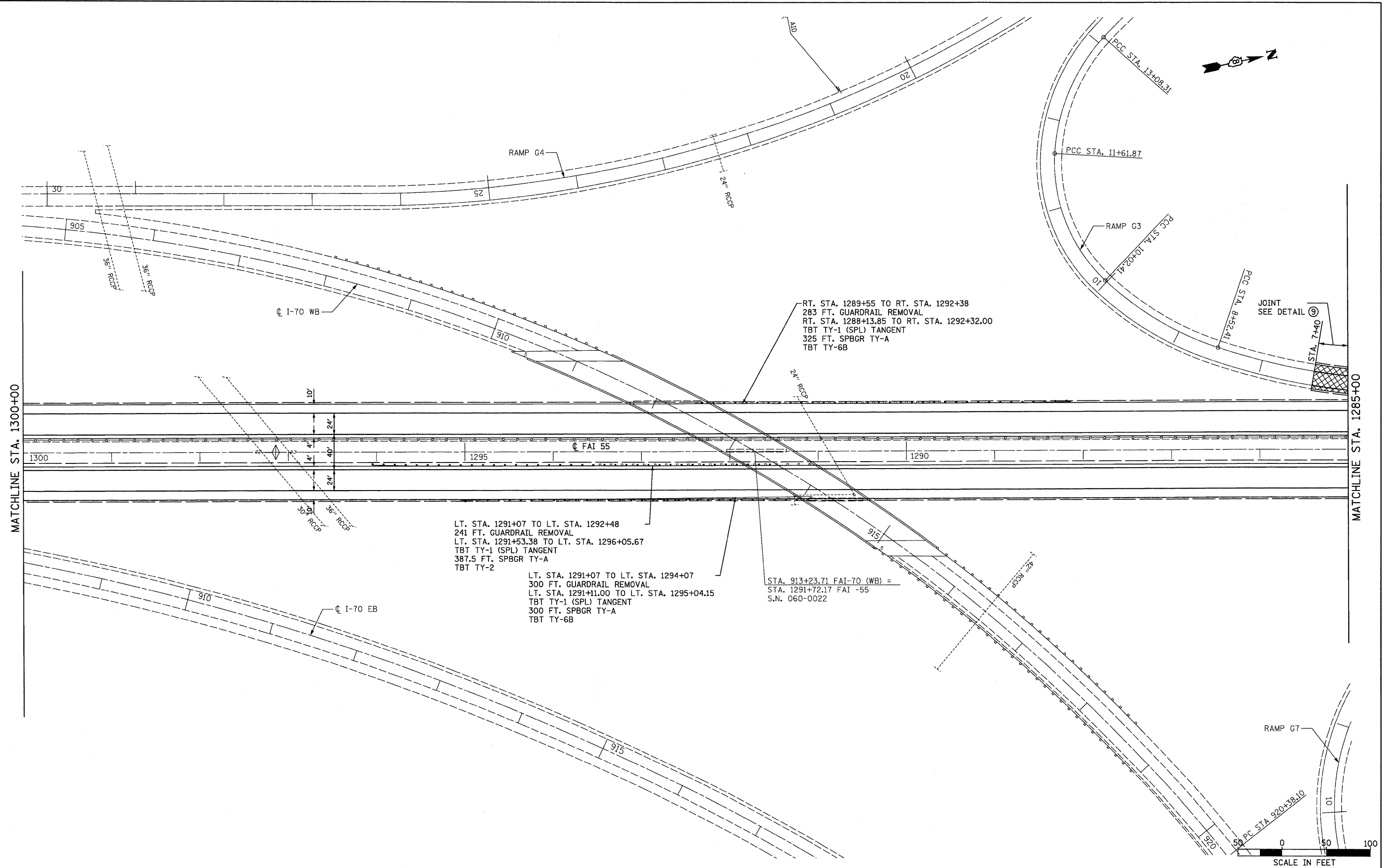

FILE NAME =  
 ...\\0876A73-ahp-plan26.dgn  

 Johnson, Depp & Oulsenberry  
 CONSULTING ENGINEERS  
 Springfield, Illinois

USER NAME = SJS  
 DESIGNED -  
 DRAWN -  
 CHECKED -  
 DATE -  
 PLOT SCALE = 50.0000' / IN.  
 PLOT DATE = 06/12/2009 09:23:56

REVISOR -  
 REVISION -  
 REVISION -  
 REVISION -

STATE OF ILLINOIS  
 DEPARTMENT OF TRANSPORTATION

F.A.I. ROUTE 70  
 ROADWAY PLANS  
 SCALE: 1" = 50'  
 SHEET NO. OF SHEETS STA. 1300+00 TO STA. 1285+00

F.A.I. RTE.	SECTION	COUNTY	TOTAL SHEETS	SHEET NO.
70		MADISON	150	50
FED. ROAD DIST. NO.		ILLINOIS FED. AID PROJECT		

CONTRACT NO. 76A73



(NOTE 2)  
 STA. 1278+00  
 REMOVE EXISTING SIGN  
 REMOVE EXISTING LIGHTING UNIT, SALVAGE  
 REPLACE WITH SIGN PANEL-TYPE 3

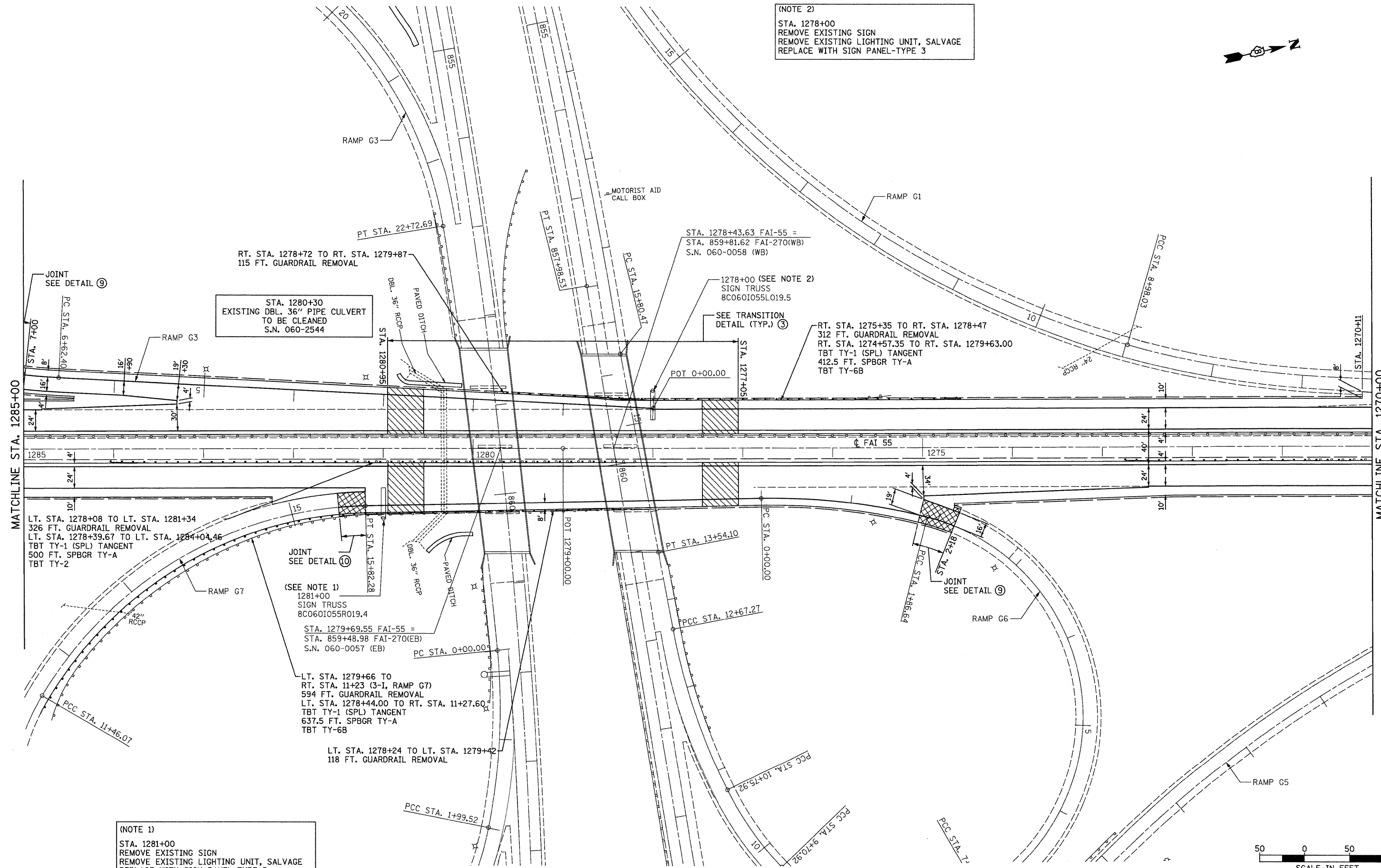

STA. 1280+30  
 EXISTING DBL. 36" PIPE CULVERT  
 TO BE CLEANED  
 S.N. 060-2544

(SEE NOTE 1)  
 1281+00  
 SIGN TRUSS  
 8C0601055R019.4

STA. 1279+69.55 FAI-55 =  
 STA. 859+48.98 FAI-270(EB)  
 S.N. 060-0057 (EB)

LT. STA. 1279+66 TO  
 RT. STA. 11+23 (3-I, RAMP G7)  
 594 FT. GUARDRAIL REMOVAL  
 LT. STA. 1278+44.00 TO RT. STA. 11+27.60  
 TBT TY-1 (SPL) TANGENT  
 637.5 FT. SPBGR TY-A  
 TBT TY-6B

LT. STA. 1278+24 TO LT. STA. 1279+42  
 118 FT. GUARDRAIL REMOVAL

RT. STA. 1275+35 TO RT. STA. 1278+47  
 312 FT. GUARDRAIL REMOVAL  
 RT. STA. 1274+57.35 TO RT. STA. 1279+63.00  
 TBT TY-1 (SPL) TANGENT  
 412.5 FT. SPBGR TY-A  
 TBT TY-6B

(NOTE 1)  
 STA. 1281+00  
 REMOVE EXISTING SIGN  
 REMOVE EXISTING LIGHTING UNIT, SALVAGE  
 REPLACE WITH SIGN PANEL-TYPE 3

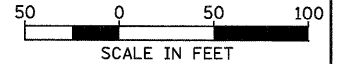

FILE NAME =  
 ...D876A73-shr-plan27.dgn  
**JD Johnson, Depp & Oulsenberry**  
 CONSULTING ENGINEERS  
 Springfield, Illinois

USER NAME = SJS  
 PLOT SCALE = 50.0000' / IN.  
 PLOT DATE = 06/12/2009 09:24:10

DESIGNED -  
 DRAWN -  
 CHECKED -  
 DATE -

REVISED -  
 REVISED -  
 REVISED -  
 REVISED -

**STATE OF ILLINOIS  
 DEPARTMENT OF TRANSPORTATION**

**F.A.I. ROUTE 70  
 ROADWAY PLANS**

SCALE: 1" = 50' SHEET NO. OF SHEETS STA. 1285+00 TO STA. 1270+00

F.A.I. RTE. 70	SECTION .	COUNTY MADISON	TOTAL SHEETS 750	SHEET NO. 51
FED. ROAD DIST. NO.		ILLINOIS FED. AID PROJECT		
CONTRACT NO. 76A73				

• 60-(7,8,9,10)RS, 60-(8,9,10)BR

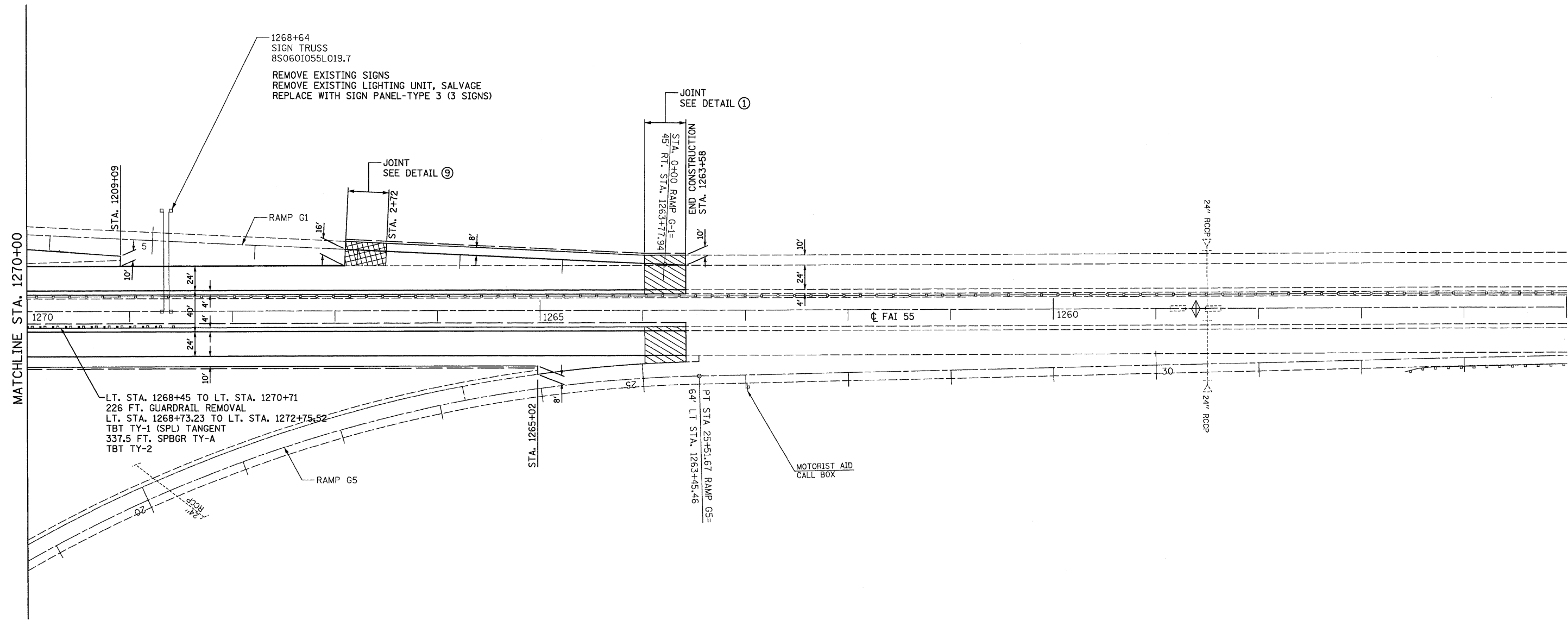

1268+64  
SIGN TRUSS  
8S060I055L019.7  
REMOVE EXISTING SIGNS  
REMOVE EXISTING LIGHTING UNIT, SALVAGE  
REPLACE WITH SIGN PANEL-TYPE 3 (3 SIGNS)

JOINT  
SEE DETAIL ①

JOINT  
SEE DETAIL ③

LT. STA. 1268+45 TO LT. STA. 1270+71  
226 FT. GUARDRAIL REMOVAL  
LT. STA. 1268+73.23 TO LT. STA. 1272+75.52  
TBT TY-1 (SPL) TANGENT  
337.5 FT. SPBGR TY-A  
TBT TY-2

MOTORIST AID  
CALL BOX

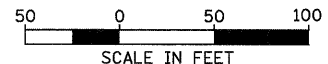

SCALE IN FEET

FILE NAME =	USER NAME = SJS	DESIGNED -	REVISED -
... \0876A73-ah-plot28.dgn		DRAWN -	REVISED -
Johnson, Depp & Gilsenberry CONSULTING ENGINEERS Springfield, Illinois	PLOT SCALE = 50.0000' / IN.	CHECKED -	REVISED -
	PLOT DATE = 06/12/2009 09:24:25	DATE -	REVISED -

**STATE OF ILLINOIS  
DEPARTMENT OF TRANSPORTATION**

**F.A.I. ROUTE 70  
ROADWAY PLANS**

SCALE: 1' = 50' SHEET NO. OF SHEETS STA. 1270+00 TO STA. 1255+00

F.A.I. RTE.	SECTION	COUNTY	TOTAL SHEETS	SHEET NO.
70	*	MADISON	150	52
FED. ROAD DIST. NO. [ILLINOIS] FED. AID PROJECT			CONTRACT NO. 76A73	

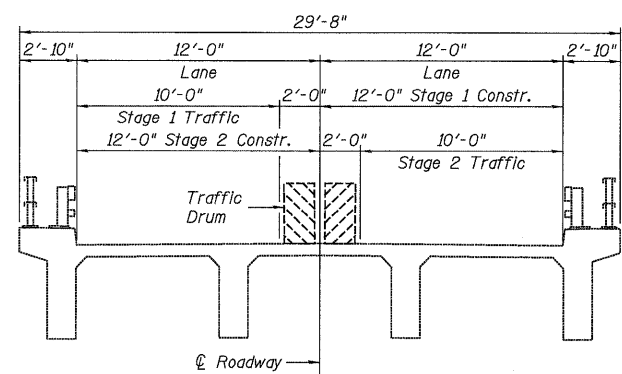

**CROSS SECTION**  
(Looking South)  
(SN 060-0172)

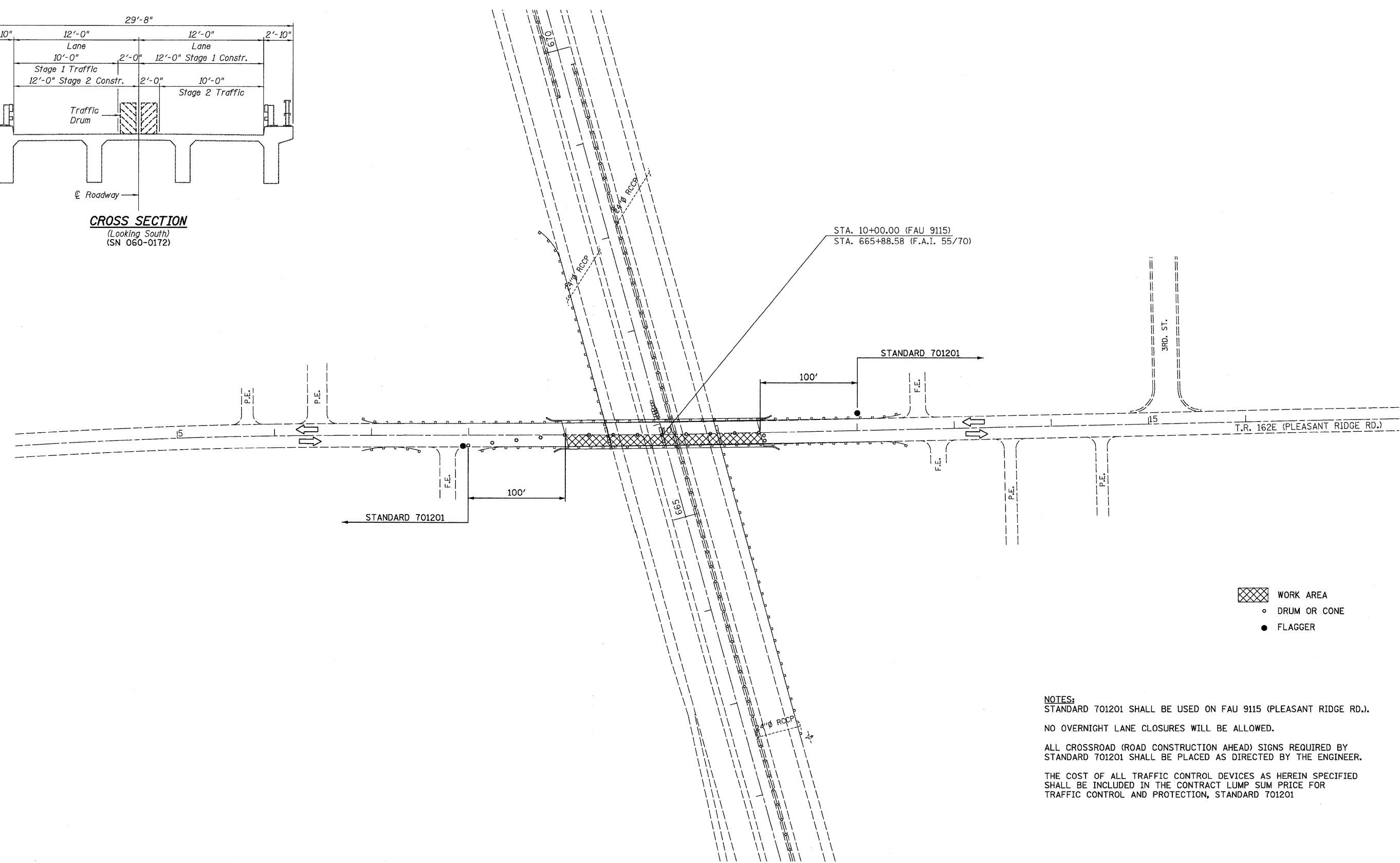

- WORK AREA
- DRUM OR CONE
- FLAGGER

**NOTES:**  
STANDARD 701201 SHALL BE USED ON FAU 9115 (PLEASANT RIDGE RD.).  
NO OVERNIGHT LANE CLOSURES WILL BE ALLOWED.  
ALL CROSSROAD (ROAD CONSTRUCTION AHEAD) SIGNS REQUIRED BY STANDARD 701201 SHALL BE PLACED AS DIRECTED BY THE ENGINEER.  
THE COST OF ALL TRAFFIC CONTROL DEVICES AS HEREIN SPECIFIED SHALL BE INCLUDED IN THE CONTRACT LUMP SUM PRICE FOR TRAFFIC CONTROL AND PROTECTION, STANDARD 701201

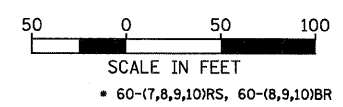

FILE NAME = ... \D876A73-ehf-staging02.dgn	USER NAME = SJS	DESIGNED -	REVISED -	<b>STATE OF ILLINOIS DEPARTMENT OF TRANSPORTATION</b>	<b>STAGE I TRAFFIC CONTROL S.N. 060-0172</b>				F.A.I. RTE. 70	SECTION *	COUNTY MADISON	TOTAL SHEETS 150	SHEET NO. 53
	PLOT SCALE = 5/8" = 1' / IN.	CHECKED -	REVISED -		SCALE:	SHEET NO.	OF	SHEETS	STA.	TO STA.	CONTRACT NO. 76A73		
	PLOT DATE = 06/12/2009 09:24:30	DATE -	REVISED -		FED. ROAD DIST. NO. ILLINOIS FED. AID PROJECT								



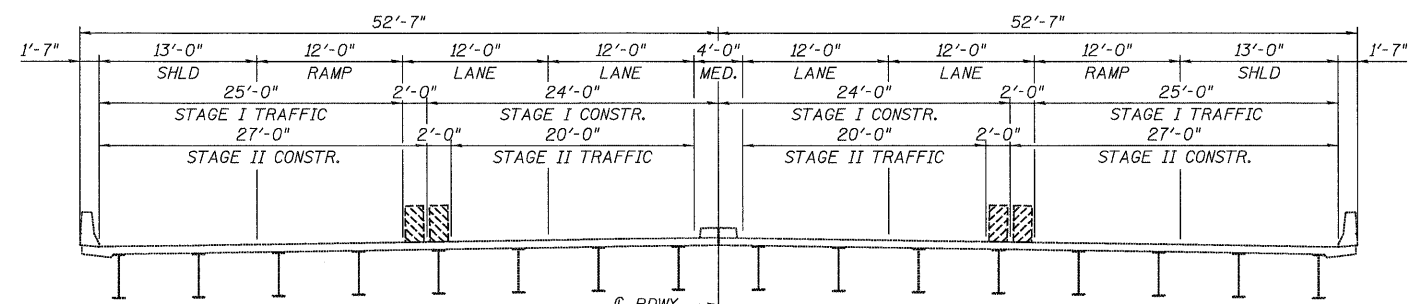

**CROSS SECTION**  
(LOOKING SOUTH)  
(SN 060-0269)

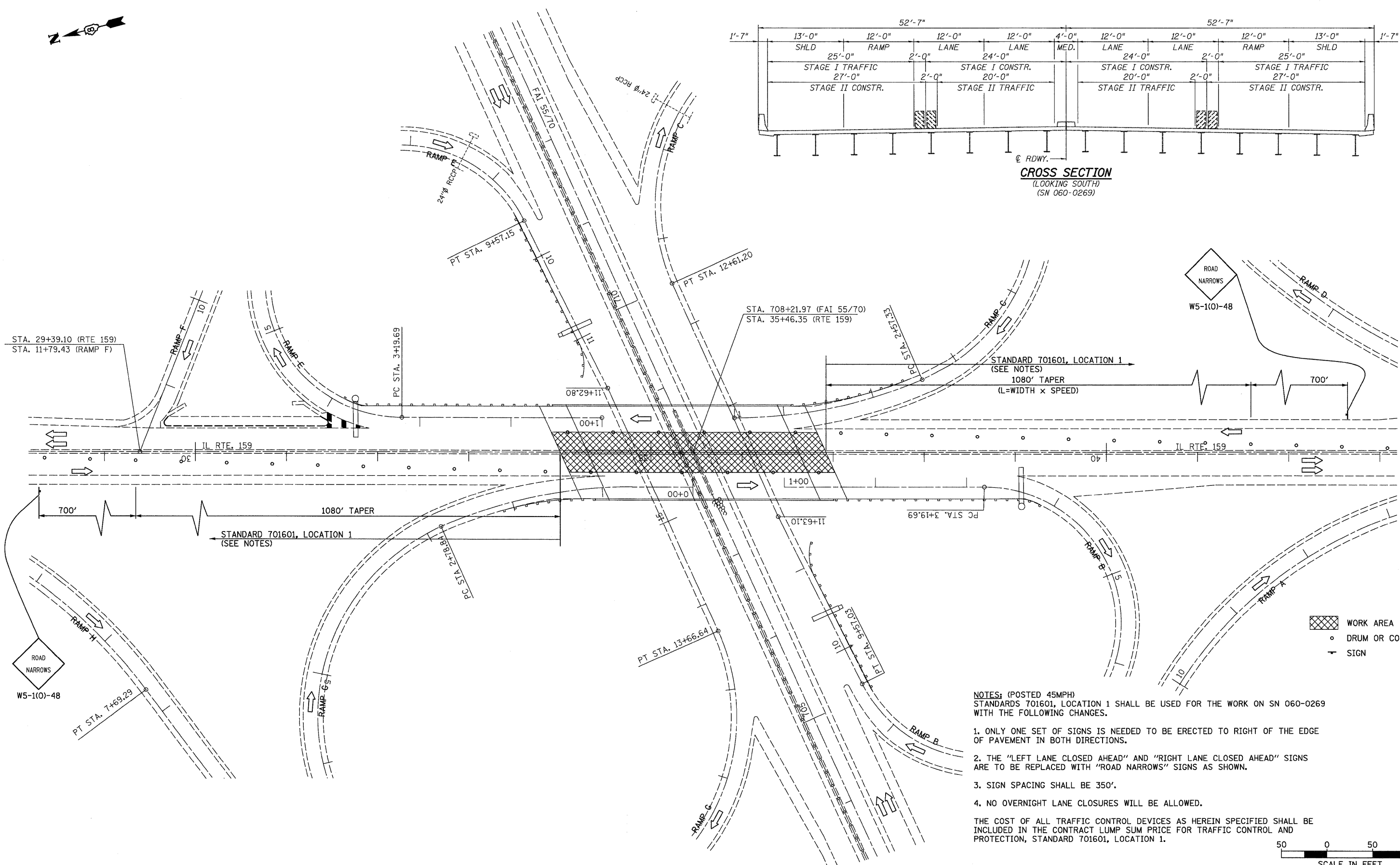

- WORK AREA
- DRUM OR CONE
- SIGN

**NOTES:** (POSTED 45MPH)  
STANDARDS 701601, LOCATION 1 SHALL BE USED FOR THE WORK ON SN 060-0269 WITH THE FOLLOWING CHANGES.

1. ONLY ONE SET OF SIGNS IS NEEDED TO BE ERECTED TO RIGHT OF THE EDGE OF PAVEMENT IN BOTH DIRECTIONS.
2. THE "LEFT LANE CLOSED AHEAD" AND "RIGHT LANE CLOSED AHEAD" SIGNS ARE TO BE REPLACED WITH "ROAD NARROWS" SIGNS AS SHOWN.
3. SIGN SPACING SHALL BE 350'.
4. NO OVERNIGHT LANE CLOSURES WILL BE ALLOWED.

THE COST OF ALL TRAFFIC CONTROL DEVICES AS HEREIN SPECIFIED SHALL BE INCLUDED IN THE CONTRACT LUMP SUM PRICE FOR TRAFFIC CONTROL AND PROTECTION, STANDARD 701601, LOCATION 1.

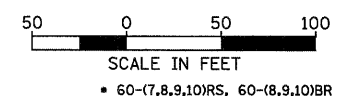

FILE NAME = ... \0876A73-sht-staging03.dgn	USER NAME = SJS	DESIGNED -	REVISED -	<b>STATE OF ILLINOIS DEPARTMENT OF TRANSPORTATION</b>	<b>STAGE I TRAFFIC CONTROL S.N. 060-0269</b>	F.A.I. RTE. 70	SECTION .	COUNTY MADISON	TOTAL SHEETS 150	SHEET NO. 55	
	PLOT SCALE = 50.0000' / IN.	DRAWN -	REVISED -			SCALE:	SHEET NO. OF SHEETS	STA. TO STA.	FED. ROAD DIST. NO.	ILLINOIS FED. AID PROJECT	CONTRACT NO. 76A73
	PLOT DATE = 06/12/2009 09:24:45	CHECKED -	REVISED -								
		DATE -	REVISED -								

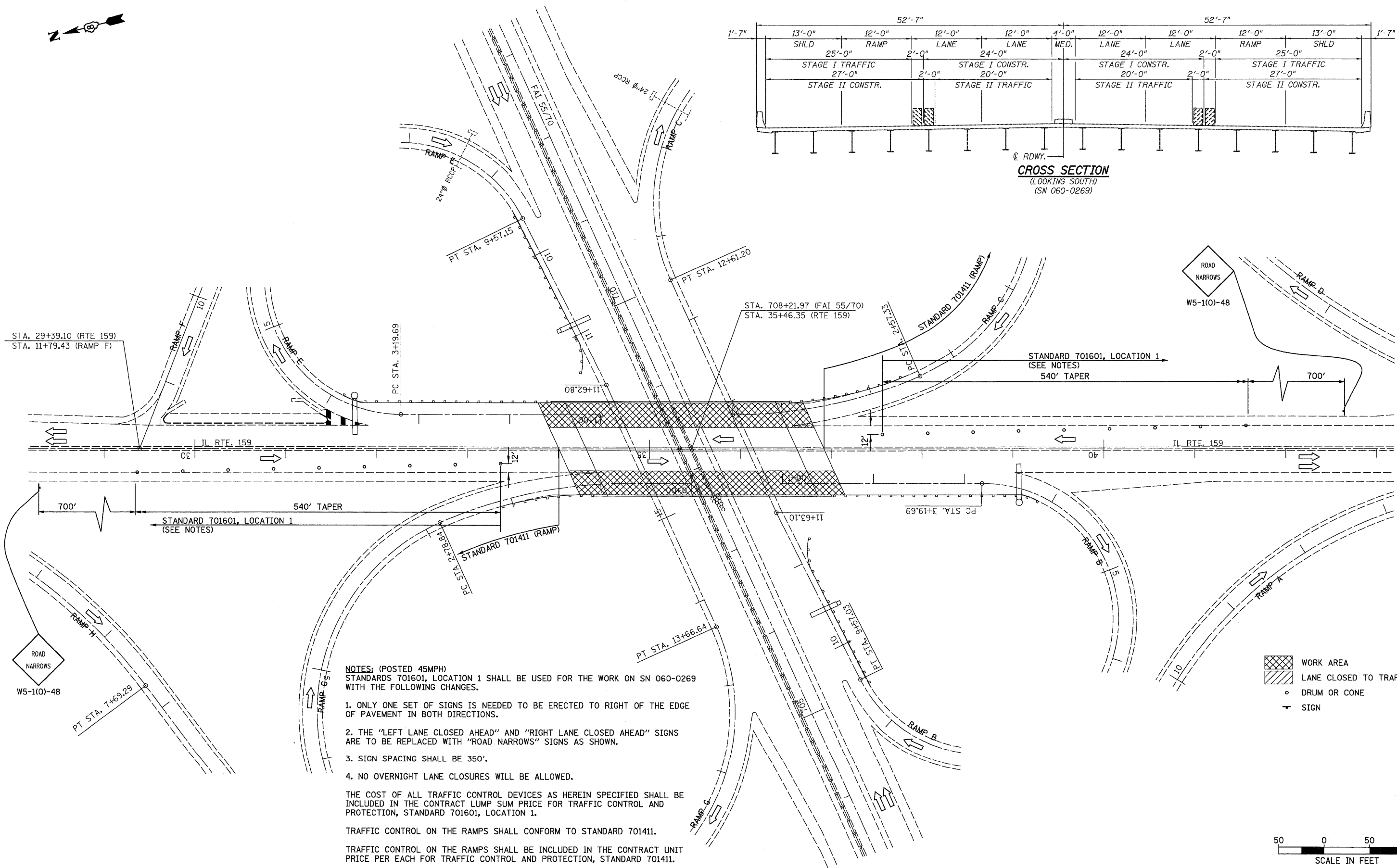
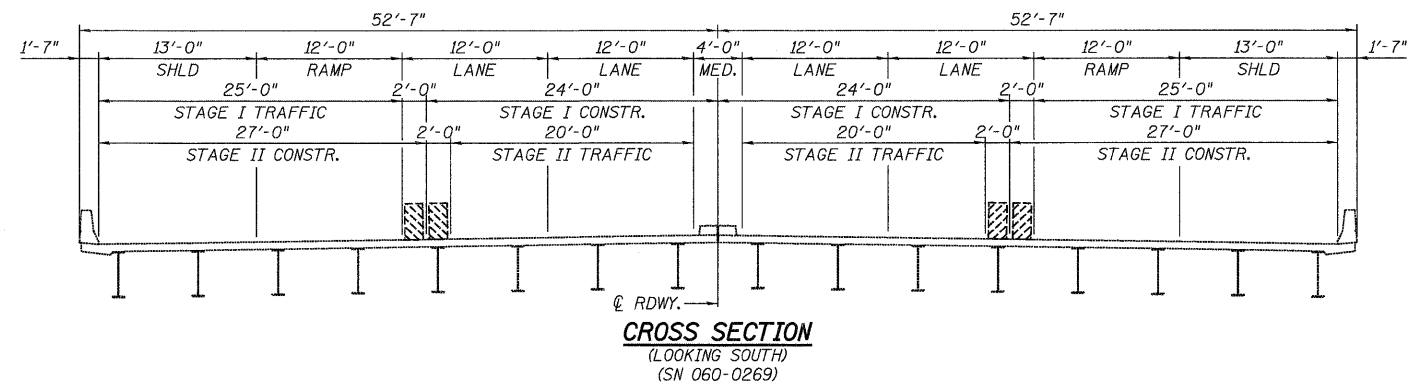

**NOTES:** (POSTED 45MPH)  
 STANDARDS 701601, LOCATION 1 SHALL BE USED FOR THE WORK ON SN 060-0269 WITH THE FOLLOWING CHANGES.

1. ONLY ONE SET OF SIGNS IS NEEDED TO BE ERECTED TO RIGHT OF THE EDGE OF PAVEMENT IN BOTH DIRECTIONS.
2. THE "LEFT LANE CLOSED AHEAD" AND "RIGHT LANE CLOSED AHEAD" SIGNS ARE TO BE REPLACED WITH "ROAD NARROWS" SIGNS AS SHOWN.
3. SIGN SPACING SHALL BE 350'.
4. NO OVERNIGHT LANE CLOSURES WILL BE ALLOWED.

THE COST OF ALL TRAFFIC CONTROL DEVICES AS HEREIN SPECIFIED SHALL BE INCLUDED IN THE CONTRACT LUMP SUM PRICE FOR TRAFFIC CONTROL AND PROTECTION, STANDARD 701601, LOCATION 1.

TRAFFIC CONTROL ON THE RAMPS SHALL CONFORM TO STANDARD 701411.

TRAFFIC CONTROL ON THE RAMPS SHALL BE INCLUDED IN THE CONTRACT UNIT PRICE PER EACH FOR TRAFFIC CONTROL AND PROTECTION, STANDARD 701411.

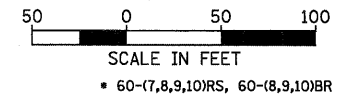
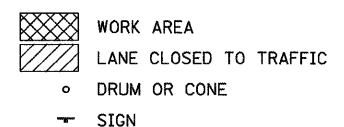

FILE NAME =	USER NAME = SJS	DESIGNED -	REVISED -	<b>STATE OF ILLINOIS DEPARTMENT OF TRANSPORTATION</b>	<b>STAGE II TRAFFIC CONTROL S.N. 060-0269</b>			F.A.I. RTE.	SECTION	COUNTY	TOTAL SHEETS	SHEET NO.
... \0878A73-ah-t-staging03.dgn	PLOT SCALE = 5/8" = 1' / IN.	DRAWN -	REVISED -		70		MADISON	150	56			
Johnson, Depp & Gulsenberry CONSULTING ENGINEERS Springfield, Illinois	PLOT DATE = 08/12/2009 09:24:48	CHECKED -	REVISED -		SCALE: SHEET NO. OF SHEETS STA. TO STA.			CONTRACT NO. 76A73				
		DATE -	REVISED -		FED. ROAD DIST. NO. ILLINOIS FED. AID PROJECT							

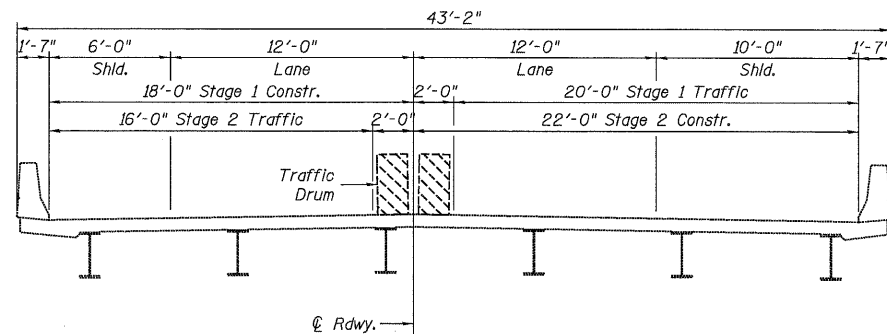

**CROSS SECTION**  
(Looking with traffic)  
(SN 060-0018/19)

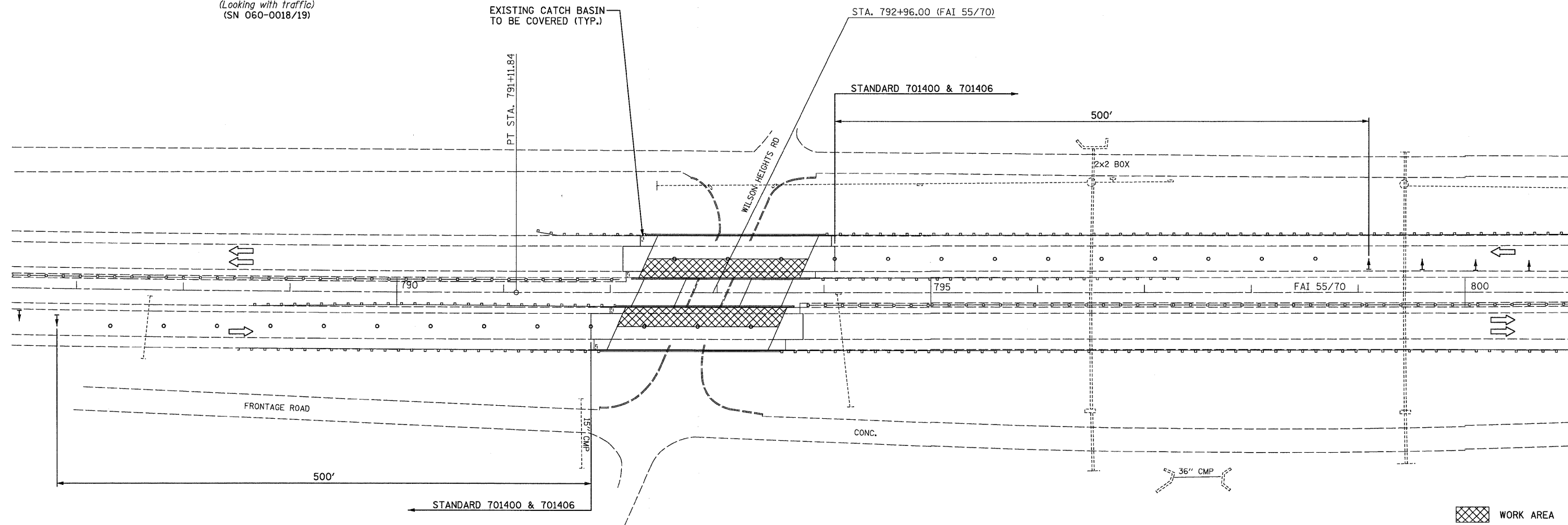

- WORK AREA
- DRUM OR CONE
- DIRECTION INDICATOR BARRICADE

**NOTES:**  
STANDARDS 701400 AND 701406 SHALL BE USED FOR THE WORK ON SN 060-0018/19.

NO PEAK HOUR LANE CLOSURES WILL BE ALLOWED.

THE CATCH BASINS IN THE APPROACH PAVEMENT SHOULDERS LOCATED ON THE WEST END OF THE STRUCTURES SHALL BE COVERED WITH A STEEL PLATE AND LEVELED WITH HMA PRIOR TO SETTING UP TRAFFIC CONTROL IN STAGE I. THIS IS TEMPORARY WITH THIS MATERIAL TO BE REMOVED AFTER STAGE II IS COMPLETED, THE COST OF THE STEEL PLATE, HMA LEVELING MATERIAL AND REMOVAL SHALL BE INCLUDED IN THE COST OF THE TRAFFIC CONTROL AND PROTECTION ITEMS.

THE COST OF ALL TRAFFIC CONTROL DEVICES AS HEREIN SPECIFIED SHALL BE INCLUDED IN THE CONTRACT LUMP SUM PRICE FOR TRAFFIC CONTROL AND PROTECTION, STANDARD 701406.

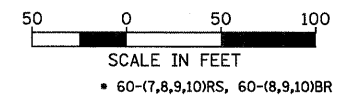

FILE NAME = ... \0878A73-ah-t-staging04.dgn 	USER NAME = SJS	DESIGNED -	REVISED -	<b>STATE OF ILLINOIS</b> <b>DEPARTMENT OF TRANSPORTATION</b>	<b>STAGE I TRAFFIC CONTROL</b> <b>S.N. 060-0018/19</b>			F.A.I. RTE. 70	SECTION *	COUNTY MADISON	TOTAL SHEETS 150	SHEET NO. 57
	PLOT SCALE = 58.0000' / IN. PLOT DATE = 06/12/2009 09:25:02	DRAWN - CHECKED - DATE -	REVISED - REVISED - REVISED -		SCALE:	SHEET NO. OF SHEETS	STA. TO STA.	FED. ROAD DIST. NO. ILLINOIS FED. AID PROJECT		CONTRACT NO. 76A73		

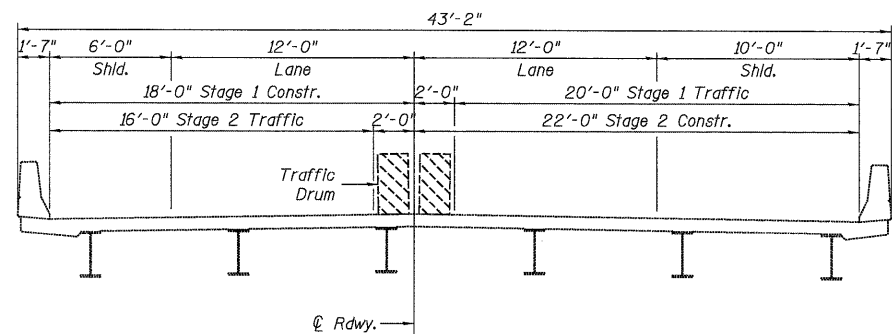
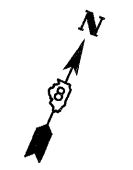

**CROSS SECTION**  
(Looking with traffic)  
(SN 060-0018/19)

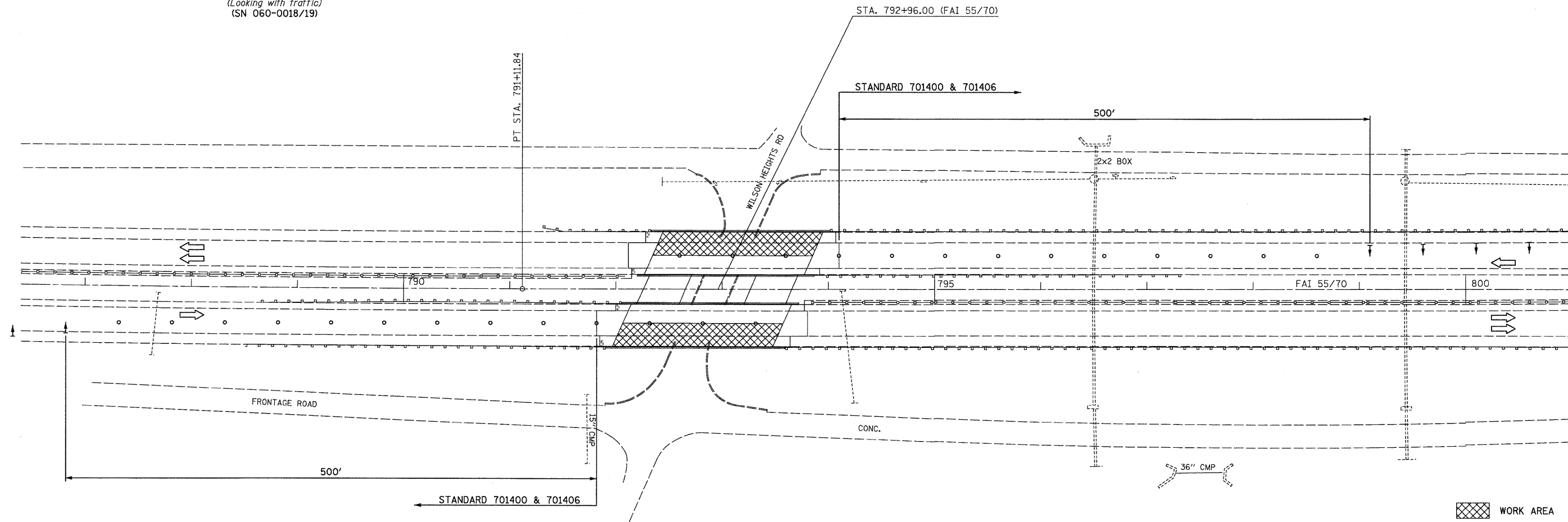

- WORK AREA
- DRUM OR CONE
- DIRECTION INDICATOR
- BARRICADE

**NOTES:**  
STANDARDS 701400 AND 701406 SHALL BE USED FOR THE WORK ON SN 060-0018/19.

NO PEAK HOUR LANE CLOSURES WILL BE ALLOWED.

THE COST OF ALL TRAFFIC CONTROL DEVICES AS HEREIN SPECIFIED SHALL BE INCLUDED IN THE CONTRACT LUMP SUM PRICE FOR TRAFFIC CONTROL AND PROTECTION, STANDARD 701406.

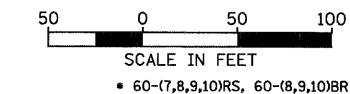

FILE NAME = ...N0878A73-ehh-staging04.dgn	USER NAME = SJS	DESIGNED -	REVISED -	<b>STATE OF ILLINOIS DEPARTMENT OF TRANSPORTATION</b>	<b>STAGE II TRAFFIC CONTROL S.N. 060-0018/19</b>			F.A.I. RTE. 70	SECTION •	COUNTY MADISON	TOTAL SHEETS 150	SHEET NO. 58
	PLOT SCALE = 50.0000' / IN.	DRAWN -	REVISED -		SCALE:	SHEET NO.	OF SHEETS	STA.	TO STA.	FED. ROAD DIST. NO.	ILLINOIS FED. AID PROJECT	CONTRACT NO. 76A73
	PLOT DATE = 06/12/2009 09:25:04	CHECKED -	REVISED -									
		DATE -	REVISED -									



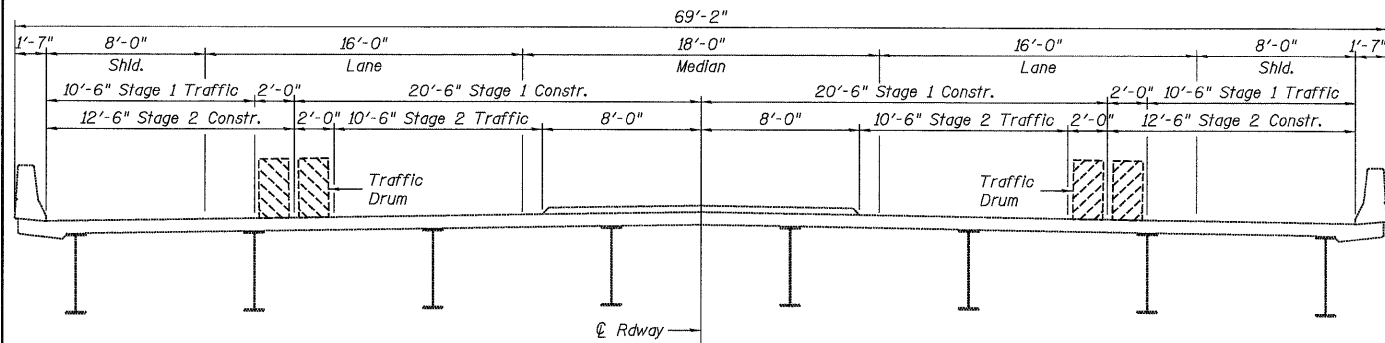

**CROSS SECTION**  
(Looking East)  
(SN 060-0267)

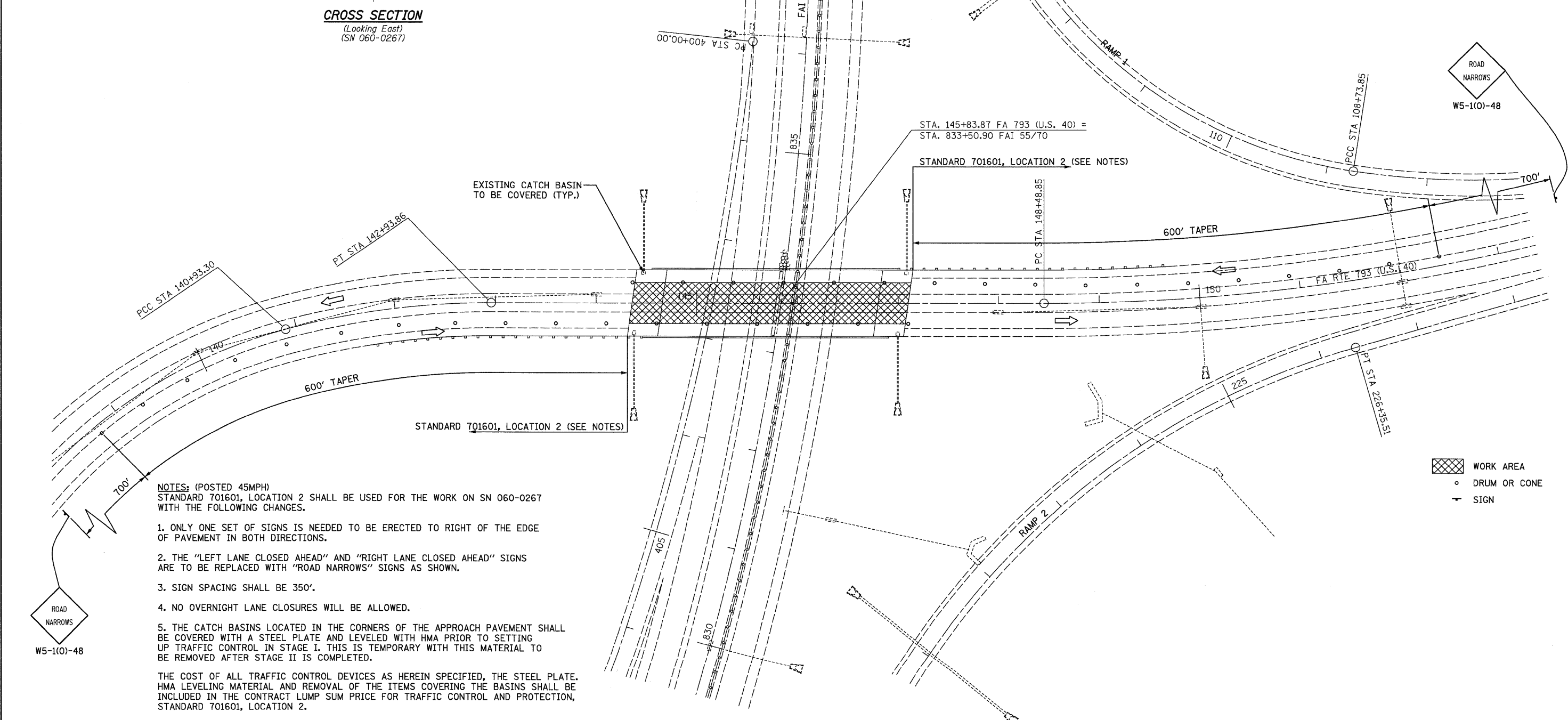
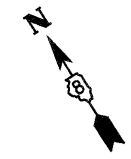

NOTES: (POSTED 45MPH)  
STANDARD 701601, LOCATION 2 SHALL BE USED FOR THE WORK ON SN 060-0267 WITH THE FOLLOWING CHANGES.

1. ONLY ONE SET OF SIGNS IS NEEDED TO BE ERECTED TO RIGHT OF THE EDGE OF PAVEMENT IN BOTH DIRECTIONS.
2. THE "LEFT LANE CLOSED AHEAD" AND "RIGHT LANE CLOSED AHEAD" SIGNS ARE TO BE REPLACED WITH "ROAD NARROWS" SIGNS AS SHOWN.
3. SIGN SPACING SHALL BE 350'.
4. NO OVERNIGHT LANE CLOSURES WILL BE ALLOWED.
5. THE CATCH BASINS LOCATED IN THE CORNERS OF THE APPROACH PAVEMENT SHALL BE COVERED WITH A STEEL PLATE AND LEVELED WITH HMA PRIOR TO SETTING UP TRAFFIC CONTROL IN STAGE I. THIS IS TEMPORARY WITH THIS MATERIAL TO BE REMOVED AFTER STAGE II IS COMPLETED.

THE COST OF ALL TRAFFIC CONTROL DEVICES AS HEREIN SPECIFIED, THE STEEL PLATE, HMA LEVELING MATERIAL AND REMOVAL OF THE ITEMS COVERING THE BASINS SHALL BE INCLUDED IN THE CONTRACT LUMP SUM PRICE FOR TRAFFIC CONTROL AND PROTECTION, STANDARD 701601, LOCATION 2.

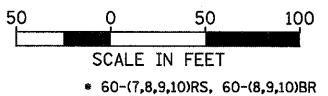

FILE NAME = ...N0876A73-ehh-staging05.dgn	USER NAME = SJS	DESIGNED -	REVISED -	<b>STATE OF ILLINOIS DEPARTMENT OF TRANSPORTATION</b>	<b>STAGE I TRAFFIC CONTROL S.N. 060-0267</b>			F.A.I. RTE. 70	SECTION .	COUNTY MADISON	TOTAL SHEETS 150	SHEET NO. 59
Johnson, Depp & Oulsenberry CONSULTING ENGINEERS Springfield, Illinois	PLOT SCALE = 50.0000' / IN.	DRAWN -	REVISED -		SCALE:	SHEET NO.	OF SHEETS	STA.	TO STA.	FED. ROAD DIST. NO.	ILLINOIS FED. AID PROJECT	CONTRACT NO. 76A73
	PLOT DATE = 06/12/2009 09:25:17	CHECKED -	REVISED -									
		DATE -	REVISED -									

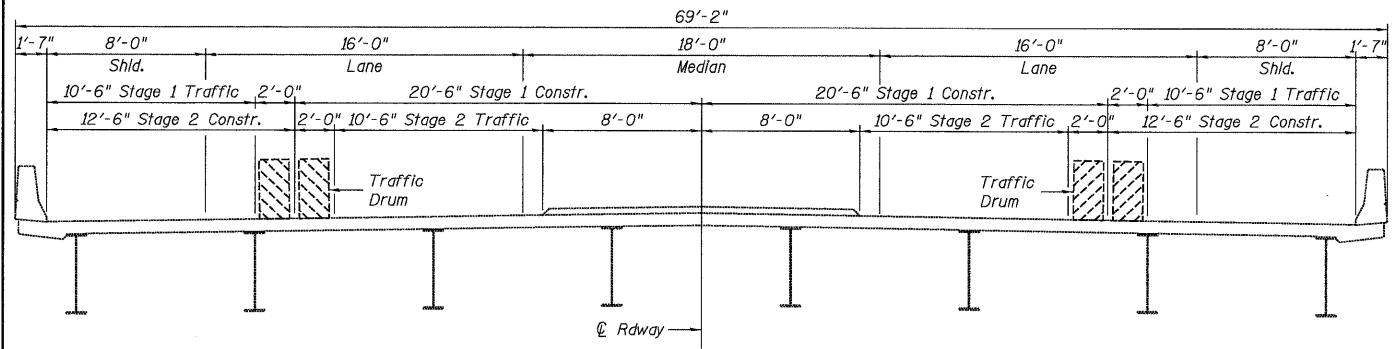

**CROSS SECTION**  
(Looking East)  
(SN 060-0267)

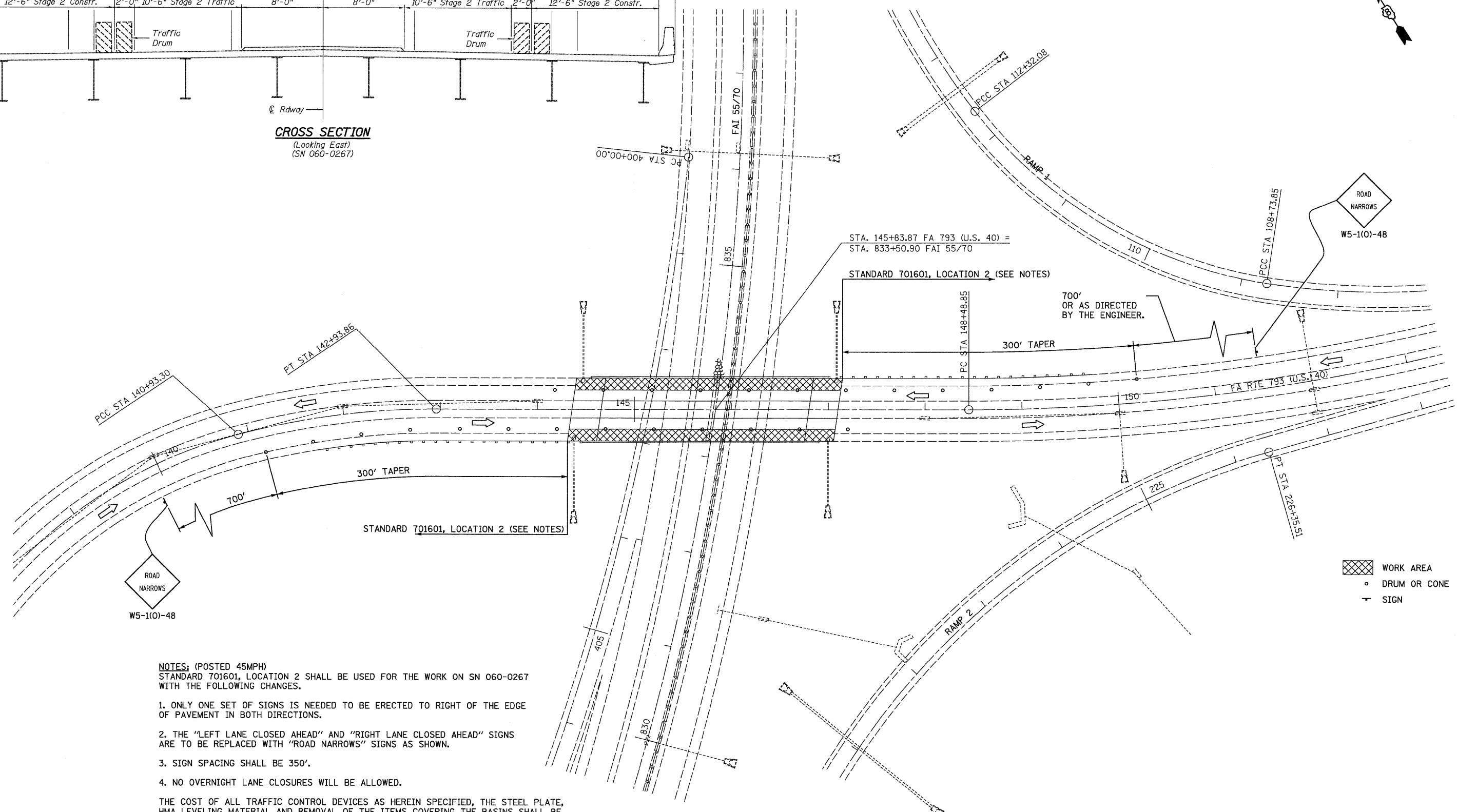

**NOTES:** (POSTED 45MPH)  
STANDARD 701601, LOCATION 2 SHALL BE USED FOR THE WORK ON SN 060-0267 WITH THE FOLLOWING CHANGES.

1. ONLY ONE SET OF SIGNS IS NEEDED TO BE ERECTED TO RIGHT OF THE EDGE OF PAVEMENT IN BOTH DIRECTIONS.
2. THE "LEFT LANE CLOSED AHEAD" AND "RIGHT LANE CLOSED AHEAD" SIGNS ARE TO BE REPLACED WITH "ROAD NARROWS" SIGNS AS SHOWN.
3. SIGN SPACING SHALL BE 350'.
4. NO OVERNIGHT LANE CLOSURES WILL BE ALLOWED.

THE COST OF ALL TRAFFIC CONTROL DEVICES AS HEREIN SPECIFIED, THE STEEL PLATE, HMA LEVELING MATERIAL AND REMOVAL OF THE ITEMS COVERING THE BASINS SHALL BE INCLUDED IN THE CONTRACT LUMP SUM PRICE FOR TRAFFIC CONTROL AND PROTECTION, STANDARD 701601, LOCATION 2.

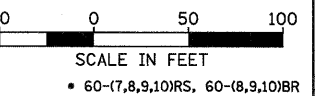

FILE NAME = ... \0876A73-ehf-staging05.dgn	USER NAME = SJS	DESIGNED -	REVISED -
Johnson, Depp & Quisenberry CONSULTING ENGINEERS Springfield, Illinois	PLOT SCALE = 58.0000' / IN.	DRAWN -	REVISED -
	CHECKED -	REVISOR -	REVISOR -
	DATE -	DATE -	DATE -

**STATE OF ILLINOIS  
DEPARTMENT OF TRANSPORTATION**

<b>STAGE II TRAFFIC CONTROL S.N. 060-0267</b>			
SCALE:	SHEET NO. OF SHEETS	STA. TO STA.	

F.A.I. RTE. 70	SECTION .	COUNTY MADISON	TOTAL SHEETS 150	SHEET NO. 60
FED. ROAD DIST. NO.		ILLINOIS FED. AID PROJECT		

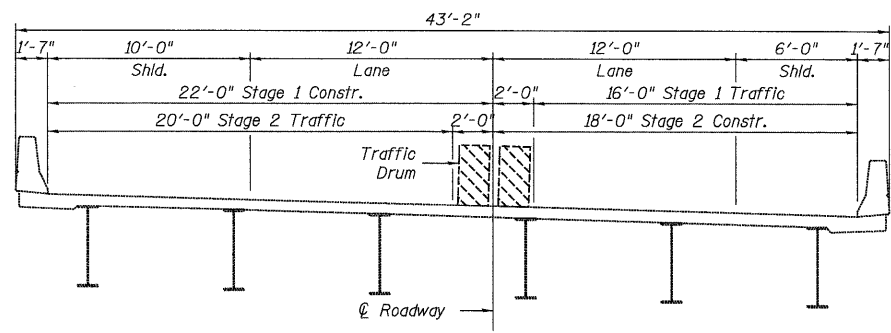

**CROSS SECTION**  
(Looking East)  
(SN 060-0022)

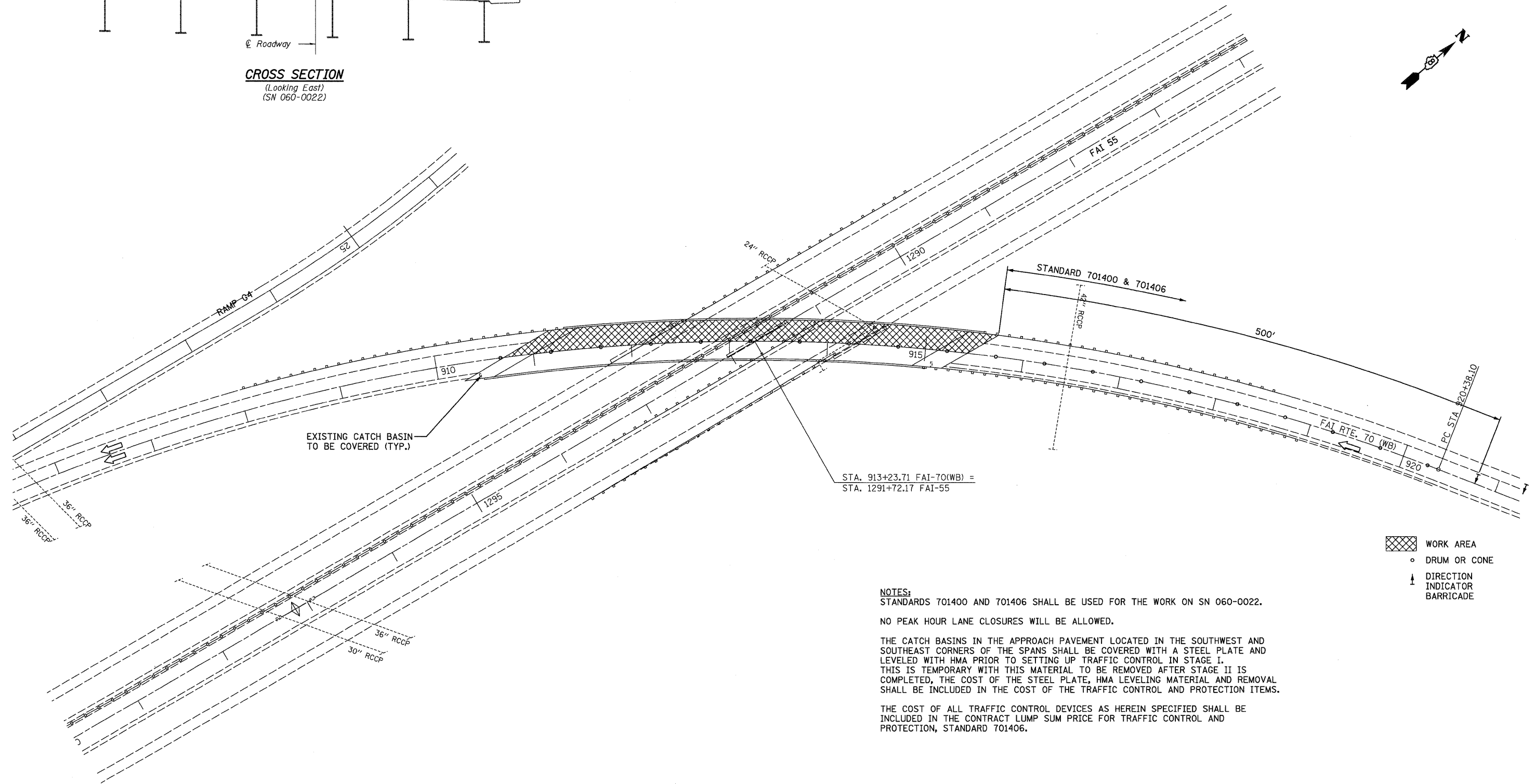
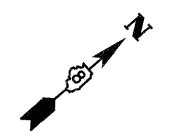

- WORK AREA
- DRUM OR CONE
- DIRECTION INDICATOR BARRICADE

**NOTES:**  
STANDARDS 701400 AND 701406 SHALL BE USED FOR THE WORK ON SN 060-0022.  
NO PEAK HOUR LANE CLOSURES WILL BE ALLOWED.  
THE CATCH BASINS IN THE APPROACH PAVEMENT LOCATED IN THE SOUTHWEST AND SOUTHEAST CORNERS OF THE SPANS SHALL BE COVERED WITH A STEEL PLATE AND LEVELED WITH HMA PRIOR TO SETTING UP TRAFFIC CONTROL IN STAGE I. THIS IS TEMPORARY WITH THIS MATERIAL TO BE REMOVED AFTER STAGE II IS COMPLETED, THE COST OF THE STEEL PLATE, HMA LEVELING MATERIAL AND REMOVAL SHALL BE INCLUDED IN THE COST OF THE TRAFFIC CONTROL AND PROTECTION ITEMS.  
THE COST OF ALL TRAFFIC CONTROL DEVICES AS HEREIN SPECIFIED SHALL BE INCLUDED IN THE CONTRACT LUMP SUM PRICE FOR TRAFFIC CONTROL AND PROTECTION, STANDARD 701406.

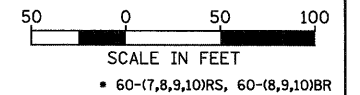

FILE NAME = ... \0876A73-ah- staging06.dgn	USER NAME = SJS	DESIGNED -	REVISED -	<b>STATE OF ILLINOIS DEPARTMENT OF TRANSPORTATION</b>	<b>STAGE I TRAFFIC CONTROL S.N. 060-0022</b>			F.A.I. RTE. 70	SECTION •	COUNTY MADISON	TOTAL SHEETS 150	SHEET NO. 61
Johnson, Depp & Oulsenberry CONSULTING ENGINEERS Springfield, Illinois	PLOT SCALE = 58.0000' / IN.	DRAWN -	REVISED -		SCALE:	SHEET NO.	OF SHEETS	STA.	TO STA.	CONTRACT NO. 76A73		
	PLOT DATE = 06/12/2009 09:25:35	CHECKED -	REVISED -		FED. ROAD DIST. NO. ILLINOIS FED. AID PROJECT							
		DATE -	REVISED -									



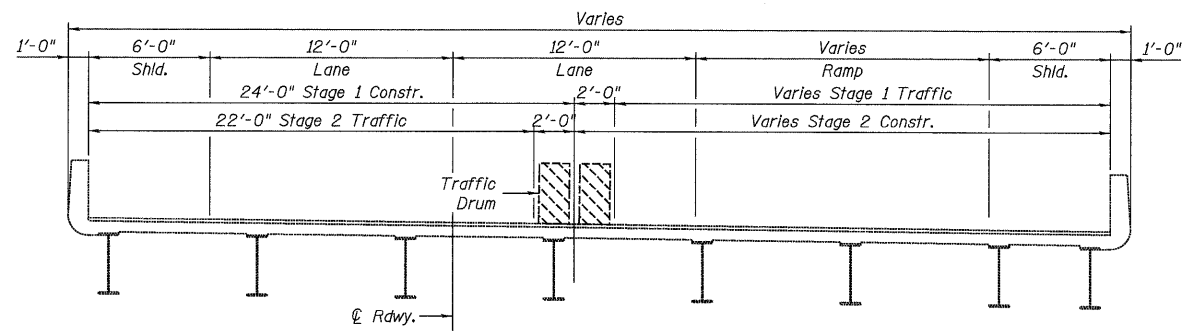

**CROSS SECTION**  
(Looking with traffic)  
(SN 060-0057/58)

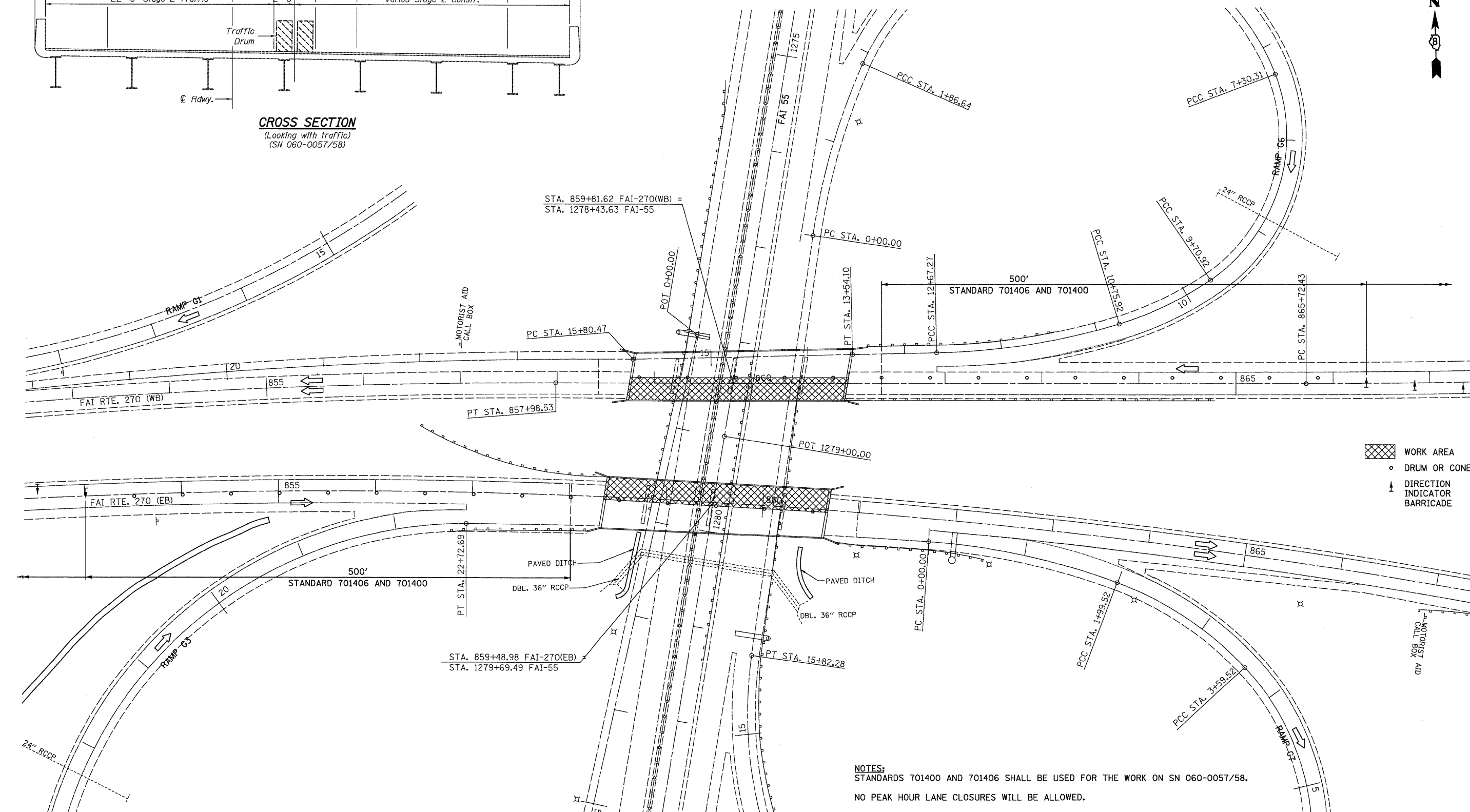

- WORK AREA
- DRUM OR CONE
- DIRECTION INDICATOR BARRICADE

**NOTES:**  
STANDARDS 701400 AND 701406 SHALL BE USED FOR THE WORK ON SN 060-0057/58.  
NO PEAK HOUR LANE CLOSURES WILL BE ALLOWED.  
THE COST OF ALL TRAFFIC CONTROL DEVICES AS HEREIN SPECIFIED SHALL BE INCLUDED IN THE CONTRACT LUMP SUM PRICE FOR TRAFFIC CONTROL AND PROTECTION, STANDARD 701406 FOR WORK ON SN 060-0057/58.

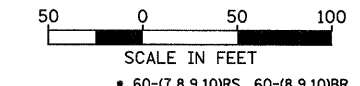

FILE NAME = ... \D878A73-shr-staging07.dgn 	USER NAME = SJS	DESIGNED -	REVISED -	<b>STATE OF ILLINOIS</b> <b>DEPARTMENT OF TRANSPORTATION</b>	<b>STAGE I TRAFFIC CONTROL</b> <b>S.N. 060-0057/58</b>			F.A.I. RTE.	SECTION	COUNTY	TOTAL SHEETS	SHEET NO.
	PLOT SCALE = 58.0202' / IN.	CHECKED -	REVISED -		SCALE:	SHEET NO.	OF	SHEETS	STA.	TO	STA.	MADISON
PLOT DATE = 06/12/2009 09:25:51	DATE -	REVISED -	REVISED -				FED. ROAD DIST. NO.	ILLINOIS	FED. AID PROJECT			

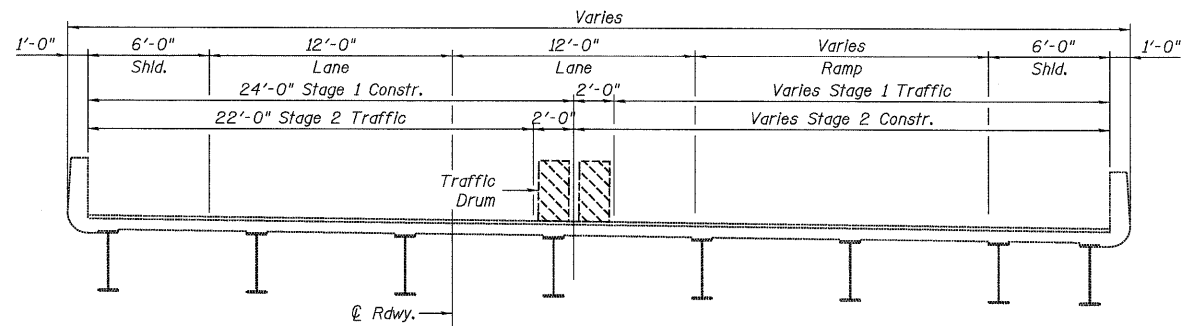

**CROSS SECTION**  
(Looking with traffic)  
(SN 060-0057/58)

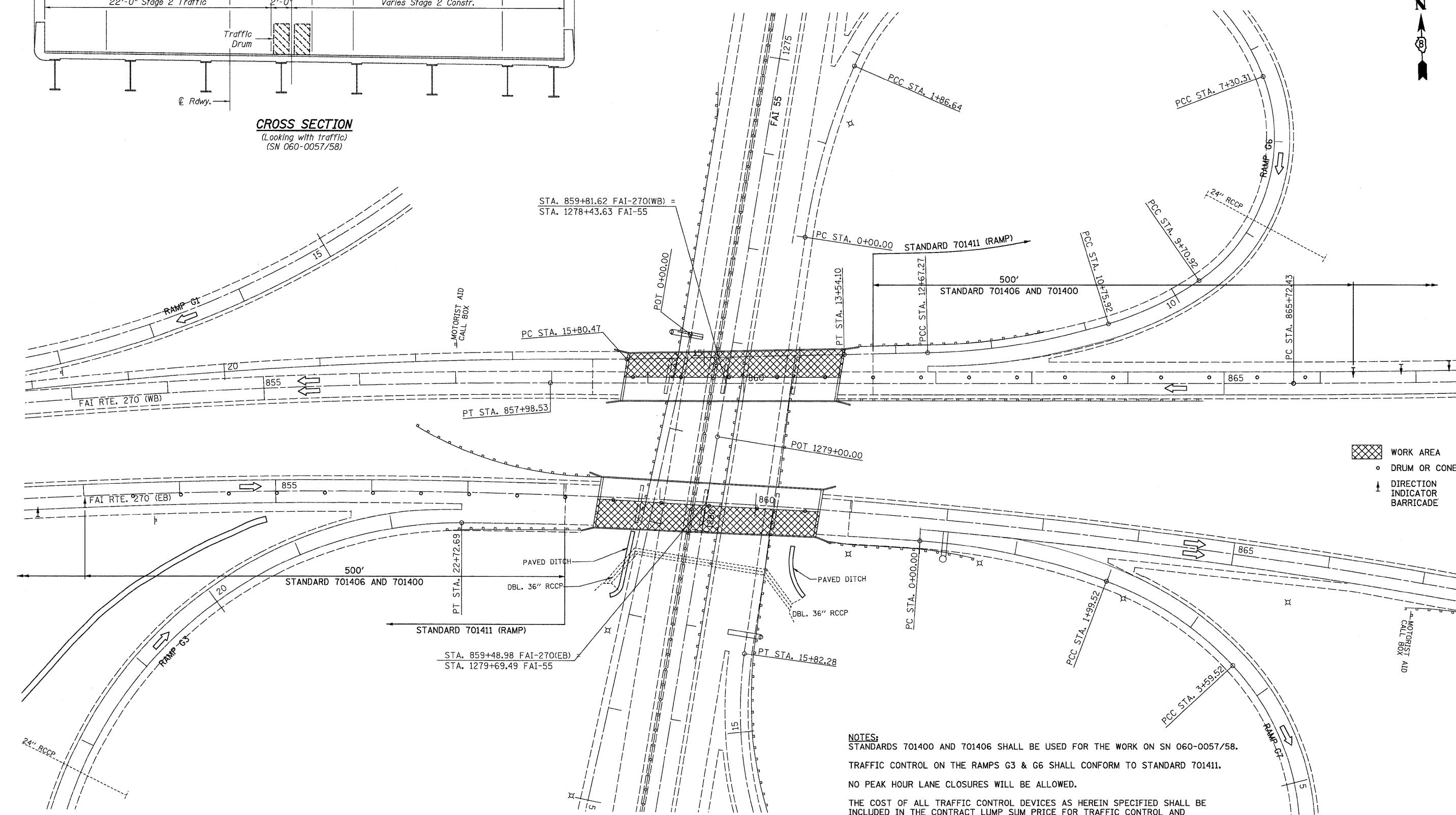

- WORK AREA
- DRUM OR CONE
- DIRECTION INDICATOR BARRICADE

**NOTES:**  
STANDARDS 701400 AND 701406 SHALL BE USED FOR THE WORK ON SN 060-0057/58.  
TRAFFIC CONTROL ON THE RAMPS G3 & G6 SHALL CONFORM TO STANDARD 701411.  
NO PEAK HOUR LANE CLOSURES WILL BE ALLOWED.  
THE COST OF ALL TRAFFIC CONTROL DEVICES AS HEREIN SPECIFIED SHALL BE INCLUDED IN THE CONTRACT LUMP SUM PRICE FOR TRAFFIC CONTROL AND PROTECTION, STANDARD 701406 FOR WORK ON SN 060-0057/58.  
TRAFFIC CONTROL ON THE RAMPS SHALL BE INCLUDED IN THE CONTRACT UNIT PRICE PER EACH FOR TRAFFIC CONTROL AND PROTECTION, STANDARD 701411.

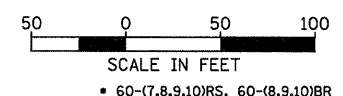

FILE NAME = ...N0876A73-sht-staging07.dgn	USER NAME = SJS	DESIGNED -	REVISED -	<b>STATE OF ILLINOIS DEPARTMENT OF TRANSPORTATION</b>	<b>STAGE II TRAFFIC CONTROL S.N. 060-0057/58</b>			F.A.J. RTE. 70	SECTION .	COUNTY MADISON	TOTAL SHEETS 150	SHEET NO. 64
	PLOT SCALE = 50.0000' / IN.	DRAWN -	REVISED -		SCALE:	SHEET NO.	OF	SHEETS	STA.	TO STA.	CONTRACT NO. 76A73	
	PLOT DATE = 06/12/2009 09:25:54	CHECKED -	REVISED -								FED. ROAD DIST. NO. ILLINOIS FED. AID PROJECT	
		DATE -	REVISED -								CONTRACT NO. 76A73	

THIS PLAN HAS BEEN PREPARED TO COMPLY WITH THE PROVISIONS OF THE NPDES PERMIT NUMBER ILR10, ISSUED BY THE ILLINOIS ENVIRONMENTAL PROTECTION AGENCY ON MAY 30, 2003 FOR STORM WATER DISCHARGES FROM CONSTRUCTION SITE ACTIVITIES. THIS PLAN HAS ALSO BEEN PREPARED TO COMPLY WITH THE PROVISIONS OF NPDES PERMIT NUMBER ILR40 FOR DISCHARGES FROM SMALL MUNICIPAL SEPARATE STORM SEWER SYSTEMS IF CHECKED BELOW.

NPDES PERMITS ASSOCIATED WITH THIS PROJECT:  
 ILR10  
 ILR40 PERMIT NO. 0493

I CERTIFY UNDER PENALTY OF LAW THAT THIS DOCUMENT AND ALL ATTACHMENTS WERE PREPARED UNDER MY DIRECTION OR SUPERVISION IN ACCORDANCE WITH A SYSTEM DESIGNED TO ASSURE THAT QUALIFIED PERSONNEL PROPERLY GATHERED AND EVALUATED THE INFORMATION SUBMITTED. BASED ON MY INQUIRY OF THE PERSON OR PERSONS WHO MANAGE THE SYSTEM, OR THOSE PERSONS DIRECTLY RESPONSIBLE FOR GATHERING THE INFORMATION, THE INFORMATION SUBMITTED IS, TO THE BEST OF MY KNOWLEDGE AND BELIEF, TRUE, ACCURATE AND COMPLETE. I AM AWARE THAT THERE ARE SIGNIFICANT PENALTIES FOR SUBMITTING FALSE INFORMATION, INCLUDING THE POSSIBILITY OF FINE AND IMPRISONMENT FOR KNOWING VIOLATIONS.

MARY C. LAMIE  
PRINT NAME  
DEPUTY DIRECTOR OF HIGHWAYS  
REGION FIVE ENGINEER  
TITLE  
IL DEPT. OF TRANSPORTATION  
AGENCY

  
SIGNATURE  
6/25/09  
DATE

I. SITE DESCRIPTION:

A. THE FOLLOWING IS A DESCRIPTION OF THE PROJECT LOCATION:

THE PROJECT IS LOCATED IN MADISON COUNTY ALONG A SECTION OF I-55/70 FROM APPROXIMATELY 1.0 MILE NORTH OF IL 157 TO 0.3 MILE NORTH OF THE I-55/70/270 INTERCHANGE AND INCLUDES THE INTERCHANGE RAMPS AT IL 159 AND US 40. THE PROJECT IS 7.7 MILES IN LENGTH.

B. THE FOLLOWING IS A DESCRIPTION OF THE CONSTRUCTION ACTIVITY WHICH IS THE SUBJECT OF THIS PLAN:

SAFETY IMPROVEMENTS ARE THE FOCUS OF THE CONSTRUCTION ACTIVITIES FOR THIS PROJECT. THESE ACTIVITIES WILL INCLUDE: 1) MILLING AND RESURFACING OF EXISTING HOT-MIX ASPHALT SURFACES TO PROVIDE EXTRA THICKNESS NEEDED BECAUSE OF HEAVY TRUCK VOLUMES, WHILE MAINTAINING MINIMUM CLEARANCES UNDER EACH OVERPASS STRUCTURE; 2) REMOVING VEGETATION AND DEBRIS TO RESTORE THE HYDRAULIC EFFICIENCY OF TWO CULVERTS (ONE AT CANTEEN CREEK AND ONE AT A DRAINAGE DITCH THAT EMPTIES INTO WENDELL BRANCH OF SILVER CREEK); 3) INSTALLATING APPROXIMATELY FOUR HUNDRED PIPE UNDERDRAIN OUTLETS IN THE SHOULDERS OF THE MAINLINE; 4) IMPROVING GUARDRAILS WITH CRASHWORTHY END TERMINALS; 5) REMOVING CALL BOX FOUNDATIONS WHERE POSTS ARE MISSING; 6) REMOVING SELECTED TREES ALONG I-55/70 BETWEEN IL 157 AND IL 159 TO DECREASE THE INCIDENCE OF LIMBS FALLING ONTO THE PAVEMENT DURING STRONG WINDS AND STORMS; AND 7) WIDENING SHOULDERS AT THE GUARD RAIL TERMINALS. RIPRAP WILL ALSO BE INSTALLED AS AN EROSION CONTROL MEASURE NEAR THE MARYVILLE WEIGH STATION.

C. THE FOLLOWING IS A DESCRIPTION OF THE INTENDED SEQUENCE OF MAJOR ACTIVITIES WHICH WILL DISTURB SOILS FOR MAJOR PORTIONS OF THE CONSTRUCTION SITE, SUCH AS GRUBBING, EXCAVATION AND GRADING:

DESCRIPTION OF INTENDED SEQUENCE FOR MAJOR CONSTRUCTION ACTIVITIES WHICH WILL DISTURB SOILS FOR MAJOR PORTIONS OF THE CONSTRUCTION SITE:

STAGE I: SELECTED TREE REMOVAL. TREES ALONG BOTH THE NORTHBOUND AND SOUTHBOUND LANES WILL BE REMOVED, INCLUDING THE STUMPS.

STAGE II: PIPE UNDERDRAIN OUTLETS. APPROXIMATELY FOUR HUNDRED PIPE UNDERDRAIN OUTLETS WILL BE INSTALLED THROUGHOUT THE ENTIRE LENGTH OF THE PROJECT.

STAGE III: SHOULDER WIDENING. APPROXIMATELY 850 SQUARE YARDS OF ABBREVIATED SHOULDER WIDENING WILL OCCUR AT GUARDRAIL TERMINALS.

STAGE IV: VEGETATION AND DEBRIS REMOVAL FROM TWO CULVERTS. THE CULVERTS AT CANTEEN CREEK AND A DRAINAGE DITCH THAT ENTERS THE WENDELL BRANCH OF SILVER CREEK WILL BE CLEARED TO IMPROVE CAPACITY AND FLOW CONDITIONS.

D. THE TOTAL AREA OF THE CONSTRUCTION SITE IS ESTIMATED TO BE APPROXIMATELY TWO HUNDRED AND SEVENTY (270) ACRES.

THE TOTAL AREA OF THE SITE THAT IS ESTIMATED WILL BE DISTURBED BY EXCAVATION, GRADING OR OTHER ACTIVITIES IS APPROXIMATELY SEVEN (7) ACRES.

E. THE FOLLOWING IS A WEIGHTED AVERAGE OF THE RUNOFF COEFFICIENT FOR THIS PROJECT AFTER CONSTRUCTION ACTIVITIES ARE COMPLETED: 0.65

F. THE FOLLOWING IS A DESCRIPTION OF THE SOIL TYPES FOUND AT THE PROJECT SITE FOLLOWED BY INFORMATION REGARDING THEIR EROSION: SEVENTEEN SOIL TYPES HAVE BEEN IDENTIFIED WITHIN THE PROJECT SITE. APPROXIMATELY 70% OF THE PROJECT SITE CONSISTS OF TWO SOIL TYPES; ORTHENTS SILT AND MENFRO SILT LOAM.

ORTHENTS SILT (801D)--A SOMEWHAT POORLY DRAINED SOIL WITH MODERATE PERMEABILITY. THIS DISTURBED SOIL HAS BEEN USED AS ROAD FILL FOR I-70, ITS RAMPS AND OTHER ROADS IN MADISON COUNTY. THIS SOIL HAS A SLIGHT SUSCEPTIBILITY TO WATER AND WIND EROSION BASED ON ITS PRESENT SLOPES.

MENFRO SILT LOAM (79B)--A GENERALLY WELL DRAINED SOIL WITH MODERATE PERMEABILITY. THIS DISTURBED SOIL HAS IDENTICAL VALUES TO ORTHENTS SILT FOR WATER AND WIND EROSION SUSCEPTIBILITY.

APPROXIMATELY 30% OF THE PROJECT SITE CONTAINS THE FOLLOWING SOILS.

WILBUR SILT LOAM (3336A)--A MODERATELY WELL DRAINED SILTY ALLUVIUM WITH MODERATE PERMEABILITY. THIS SOIL IS TYPICALLY FOUND IN FLOOD PLAINS.

CASEYVILLE SILT LOAM (267A)--A SOMEWHAT POORLY DRAINED SOIL WITH MODERATE PERMEABILITY. THIS SOIL IS TYPICALLY FOUND ON NEARLY LEVEL SUMMITS.

EDWARDSVILLE SILT LOAM (384A)--A SOMEWHAT POORLY DRAINED SOIL WITH MODERATE PERMEABILITY. THIS SOIL IS TYPICALLY FOUND IN GENTLY SLOPING AREAS.

MASCOUTAH SILTY CLAY LOAM (385A)--A POORLY DRAINED SOIL WITH A MODERATE PERMEABILITY. THIS SOIL IS THE ONLY SOIL IN THE PROJECT SITE THAT MEETS THE DEFINITION OF A HYDRIC SOIL. THIS SOIL IS TYPICALLY FOUND IN AREAS BETWEEN TWO DRAINAGEWAYS THAT SHEDS WATER TO THOSE DRAINAGEWAYS. HOWEVER, NO WETLAND IS ASSOCIATED WITH THIS SOIL IN ITS LOCATION TO THE PROJECT SITE.

WINFIELD-ORTHENTS-URBAN LAND COMPLEX (2477B)--A MODERATELY WELL DRAINED SOIL WITH MODERATE PERMEABILITY THAT HAS BEEN ALTERED THROUGH CUT AND FILL ACTIVITY.

ORION SILT LOAM (3415A)--A SOMEWHAT POORLY DRAINED SOIL WITH MODERATE PERMEABILITY THAT IS TYPICALLY FOUND IN FLOOD PLAINS.

WINFIELD SILT LOAM (477B)--A MODERATELY WELL DRAINED SOIL WITH MODERATE PERMEABILITY. THIS SOIL IS TYPICALLY FOUND WHERE EROSIONAL SIDE SLOPES ARE PRESENT.

WINFIELD SILTY CLAY LOAM (477D3)--LIKE WINFIELD SILT LOAM, THIS SOIL IS MODERATELY WELL DRAINED WITH MODERATE PERMEABILITY THAT CAN TYPICALLY BE FOUND WHERE EROSIONAL SIDE SLOPES ARE PRESENT.

SYLVAN-BOLD SILT LOAM (962D2)--A WELL DRAINED SOIL WITH MODERATE PERMEABILITY. THIS SOIL IS USUALLY FOUND ON HILL SLOPES.

SYLVAN BOLD SILT LOAM (962F2)--VIRTUALLY IDENTICAL TO SYLVAN-BOLD SILT LOAM 962D2 DESCRIBED ABOVE.

MENFRO SILT LOAM (79C)-- A WELL DRAINED SOIL WITH MODERATE PERMEABILITY THAT IS TYPICALLY FOUND ON SUMMITS, SLOPES AND BACKSLOPES.

MENFRO SILTY CLAY LOAM (79D3)--A WELL DRAINED SOIL WITH MODERATE PERMEABILITY THAT IS USUALLY FOUND ON EROSIONAL SIDE SLOPES.

MENFRO SILT LOAM (79F)--LIKE THE OTHER MENFRO SILTS, THIS IS A WELL DRAINED SOIL WITH MODERATE PERMEABILITY. THIS SOIL IS USUALLY FOUND ON SIDE SLOPES.

DOWN SOUTH SILT LOAM (283B)--A MODERATELY WELL DRAINED SOIL WITH MODERATE PERMEABILITY THAT IS TYPICALLY FOUND ON SUMMITS, SLOPES AND BACKSLOPES.

ORTHENTS SILTY UNULATING (801B)--A SOMEWHAT POORLY DRAINED SOIL TYPICALLY FOUND ON TILL PLAINS. PERMEABILITY FOR THIS SOIL RANGES FROM MODERATELY SLOW TO MODERATE.

G. THE FOLLOWING IS A DESCRIPTION OF POTENTIALLY EROSION AREAS ASSOCIATED WITH THIS PROJECT:

AREAS MOST SUSCEPTIBLE TO EROSION ON THIS PROJECT ARE WHERE TWO WINFIELD SILT LOAMS, TWO SYLVAN-BOLD SILT LOAMS, AND TWO MENFRO SILT LOAMS ARE PRESENT AT SLOPES THAT EXCEED 2 PERCENT. THE CUMULATIVE LINEAR AREA WHERE THESE SOILS ARE FOUND IS LESS THAN 1 1/2 MILES LOCATED BETWEEN 1.0 MILE NORTH OF IL 157 AND 1.0 MILE EAST OF THE IL 159 INTERCHANGE.

H. THE FOLLOWING IS A DESCRIPTION OF SOIL DISTURBING ACTIVITIES, THEIR LOCATIONS, AND THEIR EROSION FACTORS (E.G. STEEPNESS OF SLOPES, LENGTH OF SLOPES, ETC):

TWO TYPES OF SOIL DISTURBING ACTIVITIES WILL OCCUR ON THIS PROJECT: 1) RIPRAP PLACEMENT, AND 2) PIPE UNDERDRAIN INSTALLATION. APPROXIMATELY 250 SQUARE YARDS OF RIPRAP WILL BE PLACED ON A 2:1 SLOPE NEAR THE MARYVILLE WEIGH STATION. AT LOCATIONS WHERE APPROXIMATELY 400 PIPE UNDERDRAINS ARE INSTALLED, APPROXIMATELY TEN (10) FEET OF PIPE WILL BE PLACED IN TRENCHES THAT ARE APPROXIMATELY FOUR TO EIGHT INCHES WIDE.

TREE REMOVAL COULD POTENTIALLY POSE A THIRD TYPE OF SOIL DISTURBING ACTIVITY IF TREE STUMPS ARE CUT OUT OR PULLED OUT OF THE GROUND. THERE ARE 6.82 ACRES OF TREE REMOVAL INCLUDED IN THIS PROJECT.

THE PROJECT HAS NO OFF-SITE SOIL DISTURBING CONSTRUCTION ACTIVITY.

I. SEE THE EROSION CONTROL PLANS AND/OR DRAINAGE PLANS FOR THIS CONTRACT FOR INFORMATION REGARDING DRAINAGE PATTERNS, APPROXIMATE SLOPES ANTICIPATED BEFORE AND AFTER MAJOR GRADING ACTIVITIES, LOCATIONS WHERE VEHICLES ENTER OR EXIT THE SITE AND CONTROLS TO PREVENT OFF SITE SEDIMENT TRACKING (TO BE ADDED AFTER CONTRACTOR IDENTIFIES LOCATIONS), AREAS OF SOIL DISTURBANCE, THE LOCATION OF MAJOR STRUCTURAL AND NON-STRUCTURAL CONTROLS IDENTIFIED IN THE PLAN, THE LOCATION OF AREAS WHERE STABILIZATION PRACTICES ARE EXPECTED TO OCCUR, SURFACE WATERS (INCLUDING WETLANDS) AND LOCATIONS WHERE STORM WATER IS DISCHARGED TO SURFACE WATER INCLUDING WETLANDS.

J. THE FOLLOWING IS A LIST OF RECEIVING WATER(S) AND THE ULTIMATE RECEIVING WATER(S), AND AERIAL EXTENT OF WETLAND ACREAGE AT THE SITE. THE LOCATION OF THE RECEIVING WATERS CAN BE FOUND ON THE EROSION AND SEDIMENT CONTROL PLANS:

CANTEEN CREEK AND A DRAINAGE DITCH THAT EMPTIES INTO THE WENDELL BRANCH OF SILVER CREEK. NO WETLANDS ARE PRESENT ON THIS PROJECT SITE.

K. THE FOLLOWING POLLUTANTS OF CONCERN WILL BE ASSOCIATED WITH THIS CONSTRUCTION PROJECT: (CHECK ALL THAT APPLY)

- |  |   |
|--|---|
| <input checked="" type="checkbox"/> SOIL SEDIMENT  | <input type="checkbox"/> PETROLEUM (GAS, DIESEL, OIL, KEROSENE, HYDRAULIC OIL/FLUIDS) |
| <input type="checkbox"/> CONCRETE                  | <input type="checkbox"/> ANTIFREEZE / COOLANTS  |
| <input type="checkbox"/> CONCRETE TRUCK WASTE      | <input type="checkbox"/> WASTE WATER FROM CLEANING CONSTRUCTION EQUIPMENT             |
| <input type="checkbox"/> CONCRETE CURING COMPOUNDS | <input type="checkbox"/> OTHER (SPECIFY).....   |
| <input type="checkbox"/> SOLID WASTE DEBRIS        | <input type="checkbox"/> OTHER (SPECIFY).....   |
| <input type="checkbox"/> PAINTS                    | <input type="checkbox"/> OTHER (SPECIFY).....   |
| <input type="checkbox"/> SOLVENTS                  | <input type="checkbox"/> OTHER (SPECIFY).....   |
| <input type="checkbox"/> FERTILIZERS / PESTICIDES  | <input type="checkbox"/> OTHER (SPECIFY).....   |

II. CONTROLS

THIS SECTION OF THE PLAN ADDRESSES THE CONTROLS THAT WILL BE IMPLEMENTED FOR EACH OF THE MAJOR CONSTRUCTION ACTIVITIES DESCRIBED IN I.C. ABOVE AND FOR ALL USE AREAS, BORROW SITES, AND WASTE SITES. FOR EACH MEASURE DISCUSSED, THE CONTRACTOR WILL BE RESPONSIBLE FOR ITS IMPLEMENTATION AS INDICATED. THE CONTRACTOR SHALL PROVIDE TO THE RESIDENT ENGINEER A PLAN FOR THE IMPLEMENTATION OF THE MEASURES INDICATED. THE CONTRACTOR, AND SUBCONTRACTORS, WILL NOTIFY THE RESIDENT ENGINEER OF ANY PROPOSED CHANGES, MAINTENANCE, OR MODIFICATIONS TO KEEP CONSTRUCTION ACTIVITIES COMPLIANT WITH THE PERMIT. EACH SUCH CONTRACTOR HAS SIGNED THE REQUIRED CERTIFICATION ON FORMS WHICH WILL BE PROVIDED AT THE PRE-CONSTRUCTION CONFERENCE, AND ARE A PART OF, THIS PLAN:

A. EROSION AND SEDIMENT CONTROL

1. STABILIZED PRACTICES: PROVIDED BELOW IS A DESCRIPTION OF INTERIM AND PERMANENT STABILIZATION PRACTICES, INCLUDING SITE SPECIFIC SCHEDULING OF THE IMPLEMENTATION OF THE PRACTICES. SITE PLANS WILL ENSURE THAT EXISTING VEGETATION IS PRESERVED WHERE ATTAINABLE AND DISTURBED PORTIONS OF THE SITE WILL BE STABILIZED. STABILIZATION PRACTICES MAY INCLUDE BUT ARE NOT LIMITED TO: TEMPORARY SEEDING, PERMANENT SEEDING, MULCHING, GEOTEXTILES, SODDING, VEGETATIVE BUFFER STRIPS, PROTECTION OF TREES, PRESERVATION OF MATURE VEGETATION, AND OTHER APPROPRIATE MEASURES. EXCEPT AS PROVIDED BELOW IN II(A)(1)(a) AND II(A)(3), STABILIZATION MEASURES SHALL BE INITIATED AS SOON AS PRACTICABLE IN PORTIONS OF THE SITE WHERE CONSTRUCTION ACTIVITIES HAVE TEMPORARILY OR PERMANENTLY CEASED, BUT IN NO CASE MORE THAN 14 DAYS AFTER THE CONSTRUCTION ACTIVITY IN THAT PORTION OF THE SITE HAS TEMPORARILY OR PERMANENTLY CEASED ON ALL DISTURBED PORTIONS OF THE SITE WHERE CONSTRUCTION WILL NOT OCCUR FOR A PERIOD OF 21 OR MORE CALENDAR DAYS.

a. WHERE THE INITIATION OF STABILIZATION MEASURES BY THE 14TH DAY AFTER CONSTRUCTION ACTIVITY TEMPORARILY OR PERMANENTLY CEASES IS PRECLUDED BY SNOW COVER, STABILIZATION MEASURES SHALL BE INITIATED AS SOON AS PRACTICABLE THEREAFTER.

THE FOLLOWING STABILIZATION PRACTICES WILL BE USED FOR THIS PROJECT: (CHECK ALL THAT APPLY)

- |   |  |
|---|--|
| <input type="checkbox"/> PRESERVATION OF MATURE VEGETATION            | <input checked="" type="checkbox"/> EROSION CONTROL BLANKET / MULCHING |
| <input type="checkbox"/> VEGETATED BUFFER STRIPS                      | <input type="checkbox"/> SODDING                                       |
| <input type="checkbox"/> PROTECTION OF TREES                          | <input type="checkbox"/> GEOTEXTILES                                   |
| <input checked="" type="checkbox"/> TEMPORARY EROSION CONTROL SEEDING | <input type="checkbox"/> OTHER (SPECIFY).....                          |
| <input type="checkbox"/> TEMPORARY TURF (SEEDING, CLASS 7)            | <input type="checkbox"/> OTHER (SPECIFY).....                          |
| <input type="checkbox"/> TEMPORARY MULCHING                           | <input type="checkbox"/> OTHER (SPECIFY).....                          |
| <input checked="" type="checkbox"/> PERMANENT SEEDING                 | <input type="checkbox"/> OTHER (SPECIFY).....                          |

DESCRIBE HOW THE STABILIZATION PRACTICES LISTED ABOVE WILL BE UTILIZED:

TEMPORARY EROSION CONTROL SEEDING--THIS WILL BE APPLIED TO ALL BARE AREAS, AS DETERMINED BY THE ENGINEER, TO MINIMIZE THE AMOUNT OF EXPOSED SURFACE AREA.

PERMANENT SEEDING--SEEDING, CLASS 2, WILL BE INSTALLED PER IDOT SPECIFICATIONS.

MULCHING--MULCH WILL BE APPLIED WHEN THE PERMANENT SEEDING IS DONE. EROSION CONTROL BLANKET WILL NOT BE NEEDED.

2. STRUCTURAL PRACTICES: PROVIDED BELOW IS A DESCRIPTION OF STRUCTURAL PRACTICES THAT WILL BE IMPLEMENTED, TO THE DEGREE ATTAINABLE, TO DIVERT FLOWS FROM EXPOSED SOILS, STORE FLOWS OR OTHERWISE LIMIT RUNOFF AND THE DISCHARGE OF POLLUTANTS FROM EXPOSED AREAS OF THE SITE. SUCH PRACTICES MAY INCLUDE BUT ARE NOT LIMITED TO: PERIMETER EROSION BARRIER, EARTH DIKES, DRAINAGE SWALES, SEDIMENT TRAPS, DITCH CHECKS, SUBSURFACE DRAINS, PIPE SLOPE DRAINS, LEVEL SPREADERS, STORM DRAIN INLET PROTECTION, ROCK OUTLET PROTECTION, REINFORCED SOIL RETAINING SYSTEMS, GABIONS, AND TEMPORARY OR PERMANENT SEDIMENT BASINS. THE INSTALLATION OF THESE DEVICES MAY BE SUBJECT TO SECTION 404 OF THE CLEAN WATER ACT.

THE FOLLOWING STRUCTURAL PRACTICES WILL BE USED FOR THIS PROJECT:(CHECK ALL THAT APPLY)

- |  |  |
|--|--|
| <input type="checkbox"/> PERIMETER EROSION BARRIER     | <input type="checkbox"/> ROCK OUTLET PROTECTION  |
| <input type="checkbox"/> TEMPORARY DITCH CHECK         | <input checked="" type="checkbox"/> RIPRAP       |
| <input type="checkbox"/> STORM DRAIN INLET PROTECTION  | <input type="checkbox"/> GABIONS                 |
| <input type="checkbox"/> SEDIMENT TRAP                 | <input type="checkbox"/> SLOPE MATRESS           |
| <input type="checkbox"/> TEMPORARY PIPE SLOPE DRAIN    | <input type="checkbox"/> RETAINING WALLS         |
| <input type="checkbox"/> TEMPORARY SEDIMENT BASIN      | <input type="checkbox"/> SLOPE WALLS             |
| <input type="checkbox"/> TEMPORARY STREAM CROSSING     | <input type="checkbox"/> CONCRETE REVETMENT MATS |
| <input type="checkbox"/> STABILIZED CONSTRUCTION EXITS | <input type="checkbox"/> LEVEL SPREADERS         |
| <input type="checkbox"/> TURF REINFORCEMENT MATS       | <input type="checkbox"/> OTHER (SPECIFY).....    |
| <input type="checkbox"/> PERMANENT CHECK DAMS          | <input type="checkbox"/> OTHER (SPECIFY).....    |
| <input type="checkbox"/> PERMANENT SEDIMENT BASIN      | <input type="checkbox"/> OTHER (SPECIFY).....    |
| <input type="checkbox"/> AGGREGATE DITCH               | <input type="checkbox"/> OTHER (SPECIFY).....    |
| <input type="checkbox"/> PAVED DITCH                   | <input type="checkbox"/> OTHER (SPECIFY).....    |

DESCRIBE HOW THE STRUCTURAL PRACTICES LISTED ABOVE WILL BE UTILIZED:

RIPRAP--ON THE RIGHT SIDE OF NORTHBOUND LANES AT THE MARYVILLE WEIGH STATION, APPROXIMATELY 260 SQUARE YARDS OF STONE RIPRAP WILL BE USED AS AN EROSION CONTROL TO LIMIT PRE-EXISTING SOIL EROSION PROBLEMS NOT RELATED TO THE SAFETY IMPROVMENTS THAT ARE PART OF THIS PROJECT. FILTER FABRIC WILL BE INSTALLED UNDER THE STONE RIPRAP.

\* 60-(7,8,9,10)RS, 60-(8,9,10)BR

FILE NAME = ... \D878A73-ahh-swppp.dgn  
 Johnson, Depp & Gulsenberry  
CONSULTING ENGINEERS  
Springfield, Illinois

USER NAME = SJ3  
PLOT SCALE = 58.0000' / IN.  
PLOT DATE = 06/12/2009 09:26:01

DESIGNED	-	REVISED	-
DRAWN	-	REVISED	-
CHECKED	-	REVISED	-
DATE	-	REVISED	-

STATE OF ILLINOIS  
DEPARTMENT OF TRANSPORTATION

SWPPP PLAN

SCALE: SHEET NO. OF SHEETS STA. TO STA.

F.A.I. RTE.	SECTION	COUNTY	TOTAL SHEETS	SHEET NO.
70	*	MADISON	150	65
CONTRACT NO. 76A73				
FED. ROAD DIST. NO. [ILLINOIS] FED. AID PROJECT				



3. STORM WATER MANAGEMENT: PROVIDED BELOW IS A DESCRIPTION OF MEASURES THAT WILL BE INSTALLED DURING THE CONSTRUCTION PROCESS TO CONTROL POLLUTANTS IN STORM WATER DISCHARGES THAT WILL OCCUR AFTER CONSTRUCTION OPERATIONS HAVE BEEN COMPLETED. THE INSTALLATION OF THESE DEVICES MAY BE SUBJECT TO SECTION 404 OF THE CLEAN WATER ACT.

- a. SUCH PRACTICES MAY INCLUDE BUT ARE NOT LIMITED TO: STORM WATER DETENTION STRUCTURES (INCLUDING WET PONDS), STORM WATER RETENTION STRUCTURES, FLOW ATTENUATION BY USE OF OPEN VEGETATED SWALES AND NATURAL DEPRESSIONS, INFILTRATION OF RUNOFF ON SITE, AND SEQUENTIAL SYSTEMS (WHICH COMBINE SEVERAL PRACTICES). THE PRACTICES SELECTED FOR IMPLEMENTATION WERE DETERMINED ON THE BASIS OF THE TECHNICAL GUIDANCE IN SECTION 59-8 (EROSION AND SEDIMENT CONTROL) IN CHAPTER 59 (LANDSCAPE DESIGN AND EROSION CONTROL) OF THE ILLINOIS DEPARTMENT OF TRANSPORTATION BUREAU OF DESIGN AND ENVIRONMENT MANUAL. IF PRACTICES OTHER THAN THOSE DISCUSSED IN SECTION 59-8 ARE SELECTED FOR IMPLEMENTATION OR IF PRACTICES ARE APPLIED TO SITUATIONS DIFFERENT FROM THOSE COVERED IN SECTION 59-8, THE TECHNICAL BASIS FOR SUCH DECISIONS WILL BE EXPLAINED BELOW.
- b. VELOCITY DISSIPATION DEVICES WILL BE PLACED AT DISCHARGE LOCATIONS AND ALONG THE LENGTH OF ANY OUTFALL CHANNEL AS NECESSARY TO PROVIDE A NON-EROSIVE VELOCITY FLOW FROM THE STRUCTURE TO A WATER COURSE SO THAT THE NATURAL PHYSICAL AND BIOLOGICAL CHARACTERISTICS AND FUNCTIONS ARE MAINTAINED AND PROTECTED (E.G. MAINTENANCE OF HYDROLOGIC CONDITIONS SUCH AS THE HYDROPERIOD AND HYDRODYNAMICS PRESENT PRIOR TO THE INITIATION OF CONSTRUCTION ACTIVITIES).

DESCRIPTION OF STORM WATER MANAGEMENT CONTROLS:

NO STORMWATER DETENTION IS REQUIRED FOR THIS PROJECT.

4. OTHER CONTROLS:

- a. VEHICLE ENTRANCES AND EXITS - STABILIZED CONSTRUCTION ENTRANCES AND EXITS MUST BE CONSTRUCTED TO PREVENT TRACKING OF SEDIMENTS ONTO ROADWAYS.  
  
THE CONTRACTOR WILL PROVIDE THE RESIDENT ENGINEER WITH A WRITTEN PLAN IDENTIFYING THE LOCATION OF STABILIZED ENTRANCES AND EXITS AND THE PROCEDURES (SHE WILL USE TO CONSTRUCT AND MAINTAIN THEM.
- b. MATERIAL DELIVERY, STORAGE, AND USE - THE FOLLOWING BMPs SHALL BE IMPLEMENTED TO HELP PREVENT DISCHARGES OF CONSTRUCTION MATERIALS DURING DELIVERY, STORAGE, AND USE:
  - ALL PRODUCTS DELIVERED TO THE PROJECT SITE MUST BE PROPERLY LABELED.
  - WATER TIGHT SHIPPING CONTAINERS AND/OR SEMI TRAILERS SHALL BE USED TO STORE HAND TOOLS, SMALL PARTS, AND MOST CONSTRUCTION MATERIALS THAT CAN BE CARRIED BY HAND, SUCH AS PAINT CANS, SOLVENTS, AND GREASE.
  - A STORAGE/CONTAINMENT FACILITY SHOULD BE CHOSEN FOR LARGER ITEMS SUCH AS DRUMS AND ITEMS SHIPPED OR STORED ON PALLETS. SUCH MATERIAL IS TO BE COVERED BY A TIN ROOF OR LARGE SHEETS OF PLASTIC TO PREVENT PRECIPITATION FROM COMING IN CONTACT WITH THE PRODUCTS BEING STORED.
  - LARGE ITEMS SUCH AS LIGHT STANDS, FRAMING MATERIALS AND LUMBER SHALL BE STORED IN THE OPEN IN A GENERAL STORAGE AREA. SUCH MATERIAL SHALL BE ELEVATED WITH WOOD BLOCKS TO MINIMIZE CONTACT WITH STORM WATER RUNOFF.
  - SPILL CLEAN-UP MATERIALS, MATERIAL SAFETY DATA SHEETS, AN INVENTORY OF MATERIALS, AND EMERGENCY CONTACT NUMBERS SHALL BE MAINTAINED AND STORED IN ONE DESIGNATED AREA AND EACH CONTRACTOR IS TO INFORM HIS/HER EMPLOYEES AND THE RESIDENT ENGINEER OF THIS LOCATION.
- c. STOCKPILE MANAGEMENT - BMPs SHALL BE IMPLEMENTED TO REDUCE OR ELIMINATE POLLUTION OF STORM WATER FROM STOCKPILES OF SOIL AND PAVING MATERIALS SUCH AS BUT NOT LIMITED TO PORTLAND CEMENT CONCRETE RUBBLE, ASPHALT CONCRETE, ASPHALT CONCRETE RUBBLE, AGGREGATE BASE, AGGREGATE SUB BASE, AND PRE-MIXED AGGREGATE. THE FOLLOWING BMPs MAY BE CONSIDERED:
  - PERIMETER EROSION BARRIER
  - TEMPORARY SEEDING
  - TEMPORARY MULCH
  - PLASTIC COVERS
  - SOIL BINDERS
  - STORM DRAIN INLET PROTECTION

THE CONTRACTOR WILL PROVIDE THE RESIDENT ENGINEER WITH A WRITTEN PLAN OF THE PROCEDURES (SHE WILL USE ON THE PROJECT AND HOW THEY WILL BE MAINTAINED.

- d. WASTE DISPOSAL. NO MATERIALS, INCLUDING BUILDING MATERIALS, SHALL BE DISCHARGED INTO WATERS OF THE STATE, EXCEPT AS AUTHORIZED BY A SECTION 404 PERMIT.
- e. THE PROVISIONS OF THIS PLAN SHALL ENSURE AND DEMONSTRATE COMPLIANCE WITH APPLICABLE STATE AND/OR LOCAL WASTE DISPOSAL, SANITARY SEWER OR SEPTIC SYSTEM REGULATIONS.
- f. THE CONTRACTOR SHALL PROVIDE A WRITTEN AND GRAPHIC PLAN TO THE RESIDENT ENGINEER IDENTIFYING WHERE EACH OF THE ABOVE AREAS WILL BE LOCATED AND HOW THEY ARE TO BE MANAGED.

5. APPROVED STATE OR LOCAL LAWS

THE MANAGEMENT PRACTICES, CONTROLS AND PROVISIONS CONTAINED IN THIS PLAN WILL BE IN ACCORDANCE WITH IDOT SPECIFICATIONS, WHICH ARE AT LEAST AS PROTECTIVE AS THE REQUIREMENTS CONTAINED IN THE ILLINOIS ENVIRONMENTAL PROTECTION AGENCY'S ILLINOIS URBAN MANUAL, 1995. PROCEDURES AND REQUIREMENTS SPECIFIED IN APPLICABLE SEDIMENT AND EROSION SITE PLANS OR STORM WATER MANAGEMENT PLANS APPROVED BY LOCAL OFFICIALS SHALL BE DESCRIBED OR INCORPORATED BY REFERENCE IN THE SPACE PROVIDED BELOW. REQUIREMENTS SPECIFIED IN SEDIMENT AND EROSION SITE PLANS, SITE PERMITS, STORM WATER MANAGEMENT SITE PLANS OR SITE PERMITS APPROVED BY LOCAL OFFICIALS THAT ARE APPLICABLE TO PROTECTING SURFACE WATER RESOURCES ARE, UPON SUBMITTAL OF AN NOI, TO BE AUTHORIZED TO DISCHARGE UNDER PERMIT ILR10 INCORPORATED BY REFERENCE AND ARE ENFORCEABLE UNDER THIS PERMIT EVEN IF THEY ARE NOT SPECIFICALLY INCLUDED IN THE PLAN.

DESCRIPTION OF PROCEDURES AND REQUIREMENTS SPECIFIED IN APPLICABLE SEDIMENT AND EROSION SITE PLANS OR STORM WATER MANAGEMENT PLANS APPROVED BY LOCAL OFFICIALS:

ALL MANAGEMENT PRACTICES, CONTROLS, AND OTHER PROVISIONS PROVIDED IN THIS PLAN ARE IN ACCORDANCE WITH "IDOT STANDARD SPECIFICATIONS FOR ROAD AND BRIDGE CONSTRUCTION AND THE ILLINOIS URBAN MANUAL."

III. MAINTENANCE:

THE FOLLOWING IS A DESCRIPTION OF PROCEDURES THAT WILL BE USED TO MAINTAIN, IN GOOD AND EFFECTIVE OPERATING CONDITIONS, THE VEGETATION, EROSION AND SEDIMENT CONTROL MEASURES AND OTHER PROTECTIVE MEASURES IDENTIFIED IN THIS PLAN.

SEEDING--ALL ERODIBLE BARE EARTH WILL BE TEMPORARILY SEEDDED ON A WEEKLY BASIS TO MINIMIZE THE AMOUNT OF ERODIBLE SURFACE WITHIN THE CONSTRUCTION LIMITS.

THE RESIDENT ENGINEER WILL PROVIDE MAINTENANCE GUIDES TO THE CONTRACTOR FOR THESE PRACTICES. ALL LOCATIONS WHERE VEHICLES ENTER AND EXIT THE CONSTRUCTION SITE AND ALL OTHER AREAS SUBJECT TO EROSION SHOULD BE INSPECTED PERIODICALLY.

INSPECTION OF THESE AREAS SHALL BE MADE AT LEAST ONCE EVERY SEVEN DAYS AND WITHIN 24 HOURS OF THE END OF EACH 0.5 INCHES OR GREATER RAINFALL, OR AN EQUIVALENT SNOWFALL. THE PROJECT SHALL BE ADDITIONALLY INSPECTED BY THE CONSTRUCTION FIELD ENGINEER ON A BI-WEEKLY BASIS TO DETERMINE THAT EROSION CONTROL EFFORTS ARE IN PLACE AND EFFECTIVE AND IF OTHER EROSION CONTROL WORK IS NECESSARY.

IV. INSPECTIONS

QUALIFIED PERSONNEL SHALL INSPECT DISTURBED AREAS OF THE CONSTRUCTION SITE WHICH HAVE NOT YET BEEN FINALLY STABILIZED, STRUCTURAL CONTROL MEASURES, AND LOCATIONS WHERE VEHICLES AND EQUIPMENT ENTER AND EXIT THE SITE. SUCH INSPECTIONS SHALL BE CONDUCTED AT LEAST ONCE EVERY SEVEN (7) CALENDAR DAYS AND WITHIN 24 HOURS OF THE END OF A STORM THAT IS 0.5 INCHES OR GREATER OR EQUIVALENT SNOWFALL.

- A. DISTURBED AREAS, USE AREAS (STORAGE OF MATERIALS, STOCKPILES, MACHINE MAINTENANCE FUELING, ETC.), BORROW SITES, AND WASTE SITES SHALL BE INSPECTED FOR EVIDENCE OF, OR THE POTENTIAL FOR, POLLUTANTS ENTERING THE DRAINAGE SYSTEM. EROSION AND SEDIMENT CONTROL MEASURES IDENTIFIED IN THE PLAN SHALL BE OBSERVED TO ENSURE THAT THEY ARE OPERATING CORRECTLY. DISCHARGE LOCATIONS OR POINTS THAT ARE ACCESSIBLE, SHALL BE INSPECTED TO ASCERTAIN WHETHER EROSION CONTROL MEASURES ARE EFFECTIVE IN PREVENTING SIGNIFICANT IMPACTS TO RECEIVING WATERS. LOCATIONS WHERE VEHICLES ENTER OR EXIT THE SITE SHALL BE INSPECTED FOR EVIDENCE OF OFF SITE SEDIMENT TRACKING.
- B. BASED ON THE RESULTS OF THE INSPECTION, THE DESCRIPTION OF POTENTIAL POLLUTANT SOURCES IDENTIFIED IN SECTION I ABOVE AND POLLUTION PREVENTION MEASURES IDENTIFIED IN SECTION II ABOVE SHALL BE REVISED AS APPROPRIATE AS SOON AS PRACTICABLE AFTER SUCH INSPECTION. ANY CHANGES TO THIS PLAN RESULTING FROM THE REQUIRED INSPECTIONS SHALL BE IMPLEMENTED WITHIN 1/2 HOUR TO 1 WEEK BASED ON THE URGENCY OF THE SITUATION. THE RESIDENT ENGINEER WILL NOTIFY THE CONTRACTOR OF THE TIME REQUIRED TO IMPLEMENT SUCH ACTIONS THROUGH THE WEEKLY INSPECTION REPORT.
- C. A REPORT SUMMARIZING THE SCOPE OF THE INSPECTION, NAME(S) AND QUALIFICATIONS OF PERSONNEL MAKING THE INSPECTION, THE DATE(S) OF THE INSPECTION, MAJOR OBSERVATIONS RELATING TO THE IMPLEMENTATION OF THIS STORM WATER POLLUTION PREVENTION PLAN, AND ACTIONS TAKEN IN ACCORDANCE WITH SECTION IV(B) SHALL BE MADE AND RETAINED AS PART OF THE PLAN FOR AT LEAST THREE (3) YEARS AFTER THE DATE OF THE INSPECTION. THE REPORT SHALL BE SIGNED IN ACCORDANCE WITH PART VI. G OF THE GENERAL PERMIT.
- D. IF ANY VIOLATION OF THE PROVISIONS OF THIS PLAN IS IDENTIFIED DURING THE CONDUCT OF THE CONSTRUCTION WORK COVERED BY THIS PLAN, THE RESIDENT ENGINEER SHALL COMPLETE AND FILE AN "INCIDENCE OF NONCOMPLIANCE" (ION) REPORT FOR THE IDENTIFIED VIOLATION. THE RESIDENT ENGINEER SHALL USE FORMS PROVIDED BY THE ILLINOIS ENVIRONMENTAL PROTECTION AGENCY AND SHALL INCLUDE SPECIFIC INFORMATION ON THE CAUSE OF NONCOMPLIANCE, ACTIONS WHICH WERE TAKEN TO PREVENT ANY FURTHER CAUSES OF NONCOMPLIANCE, AND A STATEMENT DETAILING ANY ENVIRONMENTAL IMPACT WHICH MAY HAVE RESULTED FROM THE NONCOMPLIANCE. ALL REPORTS OF NONCOMPLIANCE SHALL BE SIGNED BY A RESPONSIBLE AUTHORITY IN ACCORDANCE WITH PART VI. G OF THE GENERAL PERMIT. THE INCIDENCE OF NONCOMPLIANCE SHALL BE MAILED TO THE FOLLOWING ADDRESS:

ILLINOIS ENVIRONMENTAL PROTECTION AGENCY  
DIVISION OF WATER POLLUTION CONTROL  
ATTN: COMPLIANCE ASSURANCE SECTION  
1021 NORTH GRAND EAST  
POST OFFICE BOX 19276  
SPRINGFIELD, ILLINOIS 62794-9276

V. NON-STORM WATER DISCHARGES:

EXCEPT FOR FLOWS FROM FIRE FIGHTING ACTIVITIES, SOURCES OF NON-STORM WATER THAT IS COMBINED WITH STORM WATER DISCHARGES ASSOCIATED WITH THE INDUSTRIAL ACTIVITY ADDRESSED IN THIS PLAN MUST BE DESCRIBED BELOW. APPROPRIATE POLLUTION PREVENTION MEASURES, AS DESCRIBED BELOW, WILL BE IMPLEMENTED FOR THE NON-STORM WATER COMPONENT(S) OF THE DISCHARGE.

A. SPILL PREVENTION AND CONTROL - BMPs SHALL BE IMPLEMENTED TO CONTAIN AND CLEAN-UP SPILLS AND PREVENT MATERIAL DISCHARGES TO THE STORM DRAIN SYSTEM. THE CONTRACTOR SHALL PRODUCE A WRITTEN PLAN STATING HOW HIS/HER COMPANY WILL PREVENT, REPORT, AND CLEAN UP SPILLS AND PROVIDE A COPY TO ALL OF HIS/HER EMPLOYEES AND THE RESIDENT ENGINEER. THE CONTRACTOR SHALL NOTIFY ALL OF HIS/HER EMPLOYEES ON THE PROPER PROTOCOL FOR REPORTING SPILLS. THE CONTRACTOR SHALL NOTIFY THE RESIDENT ENGINEER OF ANY SPILLS IMMEDIATELY.

B. CONCRETE RESIDUALS AND WASHOUT WASTES - THE FOLLOWING BMPs SHALL BE IMPLEMENTED TO CONTROL RESIDUAL CONCRETE, CONCRETE SEDIMENTS, AND RINSE WATER:

1. TEMPORARY CONCRETE WASHOUT FACILITIES SHALL BE CONSTRUCTED FOR RINSING OUT CONCRETE TRUCKS. SIGNS SHALL BE INSTALLED DIRECTING CONCRETE TRUCK DRIVERS WHERE DESIGNATED WASHOUT FACILITIES ARE LOCATED.
2. THE CONTRACTOR SHALL HAVE THE LOCATION OF TEMPORARY CONCRETE WASHOUT FACILITIES APPROVED BY THE RESIDENT ENGINEER.
3. ALL TEMPORARY CONCRETE WASHOUT FACILITIES ARE TO BE INSPECTED BY THE CONTRACTOR AFTER EACH USE AND ALL SPILLS MUST BE REPORTED TO THE RESIDENT ENGINEER AND CLEANED UP IMMEDIATELY.
4. CONCRETE WASTE SOLIDS/LIQUIDS SHALL BE DISPOSED OF PROPERLY.

C. LITTER MANAGEMENT - A PROPER NUMBER OF DUMPSTERS SHALL BE PROVIDED ON SITE TO HANDLE DEBRIS AND LITTER ASSOCIATED WITH THE PROJECT. THE CONTRACTOR IS RESPONSIBLE FOR ENSURING HIS/HER EMPLOYEES PLACE ALL LITTER INCLUDING MARKING PAINT CANS, SODA CANS, FOOD WRAPPERS, WOOD LATHE, MARKING RIBBON, CONSTRUCTION STRING, AND ALL OTHER CONSTRUCTION RELATED LITTER IN THE PROPER DUMPSTERS.

D. VEHICLE AND EQUIPMENT CLEANING - VEHICLES AND EQUIPMENT ARE TO BE CLEANED IN DESIGNATED AREAS ONLY, PREFERABLY OFF SITE.

E. VEHICLE AND EQUIPMENT FUELING - A VARIETY OF BMPs CAN BE IMPLEMENTED DURING FUELING OF VEHICLES AND EQUIPMENT TO PREVENT POLLUTION. THE CONTRACTOR SHALL INFORM THE RESIDENT ENGINEER AS TO WHICH BMPs WILL BE USED ON THE PROJECT. THE CONTRACTOR SHALL INFORM THE RESIDENT ENGINEER HOW (S)HE WILL BE INFORMING HIS/HER EMPLOYEES OF THESE BMPs (I.E. SIGNS, TRAINING, ETC.). BELOW ARE A FEW EXAMPLES OF THESE BMPs:





1. CONTAINMENT
2. SPILL PREVENTION AND CONTROL
3. USE OF DRIP PANS AND ABSORBENTS
4. AUTOMATIC SHUT-OFF NOZZLES
5. TOPPING OFF RESTRICTIONS
6. LEAK INSPECTION AND REPAIR

F. VEHICLE AND EQUIPMENT MAINTENANCE - ON SITE MAINTENANCE MUST BE PERFORMED IN ACCORDANCE WITH ALL ENVIRONMENTAL LAWS SUCH AS PROPER STORAGE AND NO DUMPING OF OLD ENGINE OIL OR OTHER FLUIDS ON SITE.

VI. FAILURE TO COMPLY:

FAILURE TO COMPLY WITH ANY PROVISIONS OF THIS STORM WATER POLLUTION PREVENTION PLAN WILL RESULT IN THE IMPLEMENTATION OF AN EROSION AND SEDIMENT CONTROL DEFICIENCY DEDUCTION AGAINST THE CONTRACTOR AND/OR PENALTIES UNDER THE NPDES PERMIT WHICH COULD BE PASSED ONTO THE CONTRACTOR.

LEGEND

-  TEMPORARY DITCH CHECK- ROLLED EXCELSIOR, SILT WEDGES/PANELS
-  TEMPORARY DITCH CHECK- AGGREGATE
-  EROSION CONTROL BLANKET
-  PERIMETER EROSION BARRIER- SILT FILTER FENCE OR OTHER AS APPROVED BY THE ENGINEER
-  INLET AND PIPE PROTECTION- STRAW BALES, FILTER FABRIC, AGGREGATES

FILE NAME = ... \D876A73-shr-swppp.dgn	USER NAME = SJS	DESIGNED -	REVISED -	<b>STATE OF ILLINOIS DEPARTMENT OF TRANSPORTATION</b>	<b>SWPPP PLAN</b>	F.A.I. RTE.	SECTION	COUNTY	TOTAL SHEETS	SHEET NO.	
	PLOT SCALE = 50.0000' / IN.	DRAWN -	REVISED -			70	*	MADISON	150	66	
	PLOT DATE = 06/12/2009 09:26:09	CHECKED -	REVISED -			CONTRACT NO. 76A73					
		DATE -	REVISED -			SCALE:	SHEET NO.	OF	SHEETS	STA.	TO
						FED. ROAD DIST. NO.		ILLINOIS		FED. AID PROJECT	

\* 60-(7,8,9,10)RS, 60-(8,9,10)BR



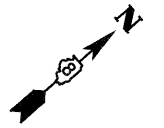

BEGIN PROJECT  
STA. 565+00

BEGIN CONSTRUCTION  
STA. 564+60

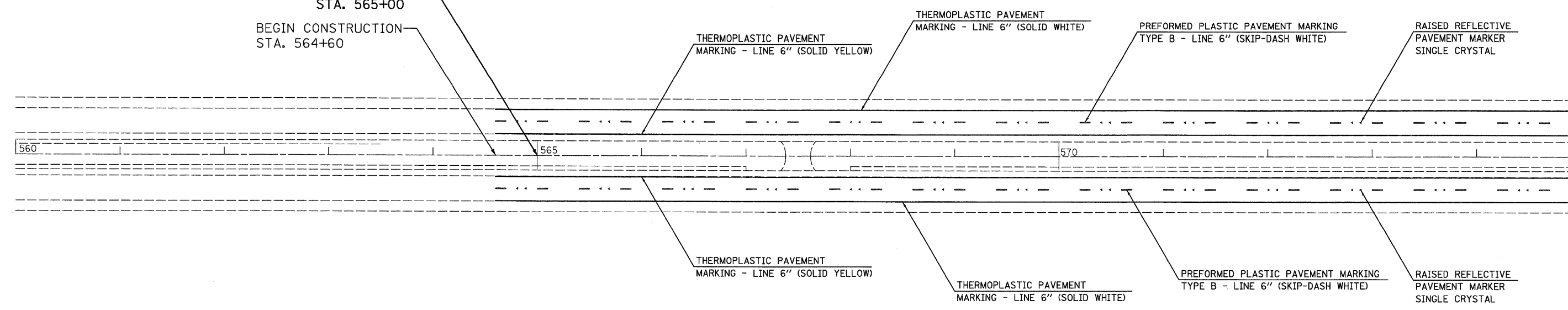

MATCHLINE STA. 575+00

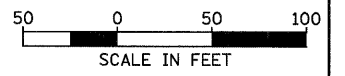

FILE NAME = ...\D876A73-sht-pmk01.dgn 	USER NAME = SJS	DESIGNED -	REVISED -	<b>STATE OF ILLINOIS</b> <b>DEPARTMENT OF TRANSPORTATION</b>	<b>F.A.I. ROUTE 70</b> <b>PAVEMENT MARKING PLANS</b>			F.A.I. RTE. 70	SECTION *	COUNTY MADISON	TOTAL SHEETS 150	SHEET NO. 67
	PLOT SCALE = 50.0000' / IN. PLOT DATE = 06/12/2009 09:26:28	CHECKED -	REVISED -		REVISED -	SCALE: 1" = 50'	SHEET NO. OF SHEETS	STA. 560+00 TO STA. 575+00	FED. ROAD DIST. NO.	ILLINOIS FED. AID PROJECT	CONTRACT NO. 76A73	* 60-(7,8,9,10)RS, 60-(8,9,10)BR

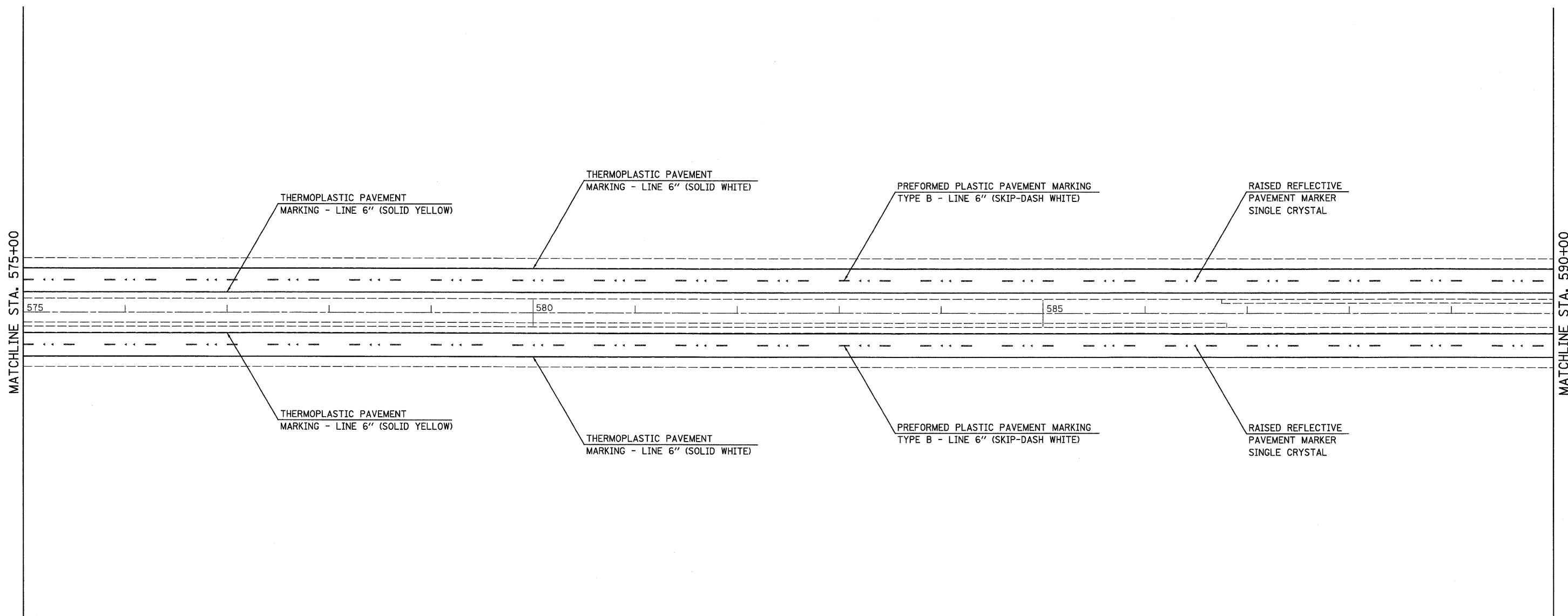
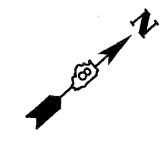

MATCHLINE STA. 575+00

MATCHLINE STA. 590+00

575

580

585

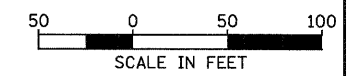

• 60-(7,8,9,10)RS, 60-(8,9,10)BR

FILE NAME = ..._0878A73-shr-pmk02.dgn 	USER NAME = SJS	DESIGNED - DRAWN -	REVISED - REVISED -	<b>STATE OF ILLINOIS</b> <b>DEPARTMENT OF TRANSPORTATION</b>	<b>F.A.I. ROUTE 70</b> <b>PAVEMENT MARKING PLANS</b>			F.A.I. RTE. 70	SECTION •	COUNTY MADISON	TOTAL SHEETS 150	SHEET NO. 68
	PLOT SCALE = 50.0000' / IN. PLOT DATE = 06/12/2009 09:26:40	CHECKED - DATE -	REVISED - REVISED -		SCALE: 1' = 50' SHEET NO. OF SHEETS STA. 575+00 TO STA. 590+00	FED. ROAD DIST. NO. ILLINOIS FED. AID PROJECT	CONTRACT NO. 76A73					

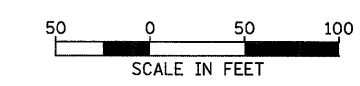
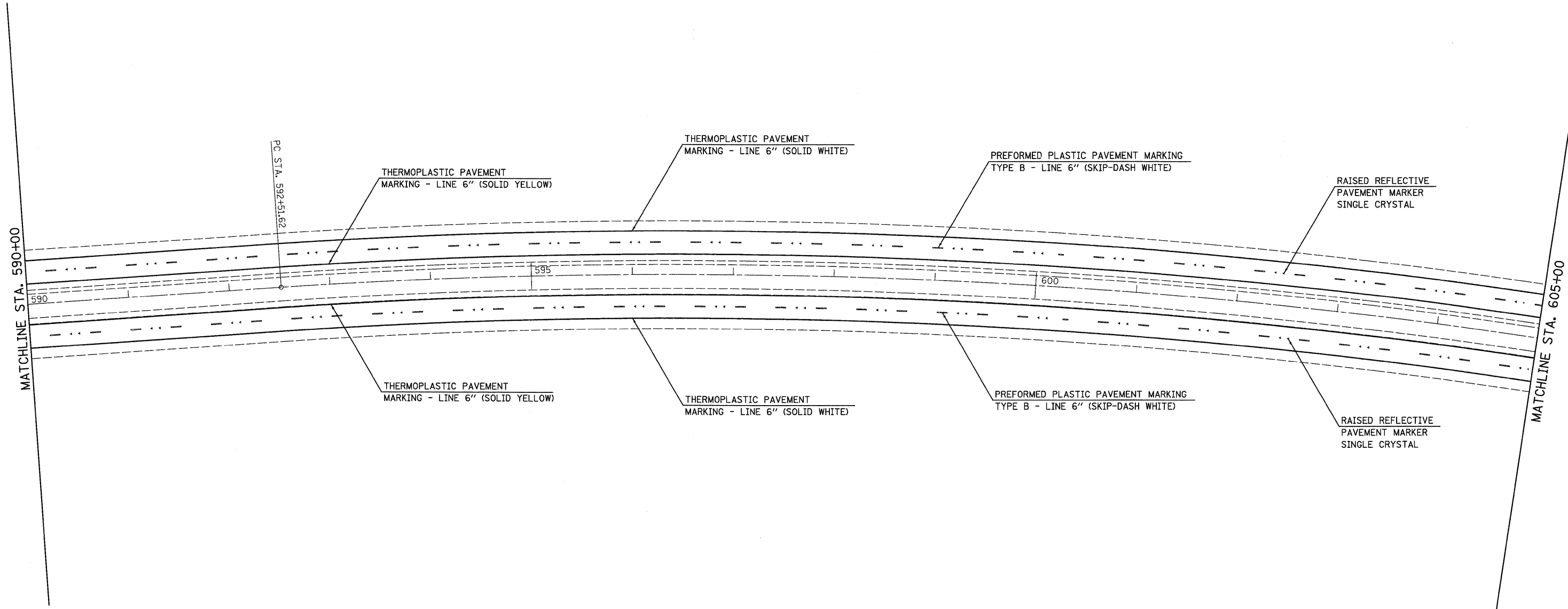
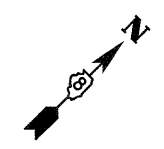

• 60-(7,8,9,10)RS, 60-(8,9,10)BR

FILE NAME = ...N0876A73-sht-pmk03.dgn 	USER NAME = SJS	DESIGNED -	REVISED -	<b>STATE OF ILLINOIS</b> <b>DEPARTMENT OF TRANSPORTATION</b>	<b>F.A.I. ROUTE 70</b> <b>PAVEMENT MARKING PLANS</b>		F.A.I. RTE.	SECTION	COUNTY	TOTAL SHEETS	SHEET NO.
	PLOT SCALE = 50.0000' / IN.	DRAWN -	REVISED -				70	.	MADISON	150	69
	PLOT DATE = 06/12/2009 09:26:52	CHECKED -	REVISED -				CONTRACT NO. 76A73				
		DATE -	REVISED -				FED. ROAD DIST. NO. [ILLINOIS] FED. AID PROJECT				
				SCALE: 1' = 50'		SHEET NO. OF SHEETS		STA. 590+00 TO STA. 605+00			

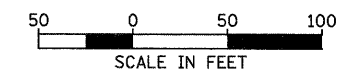
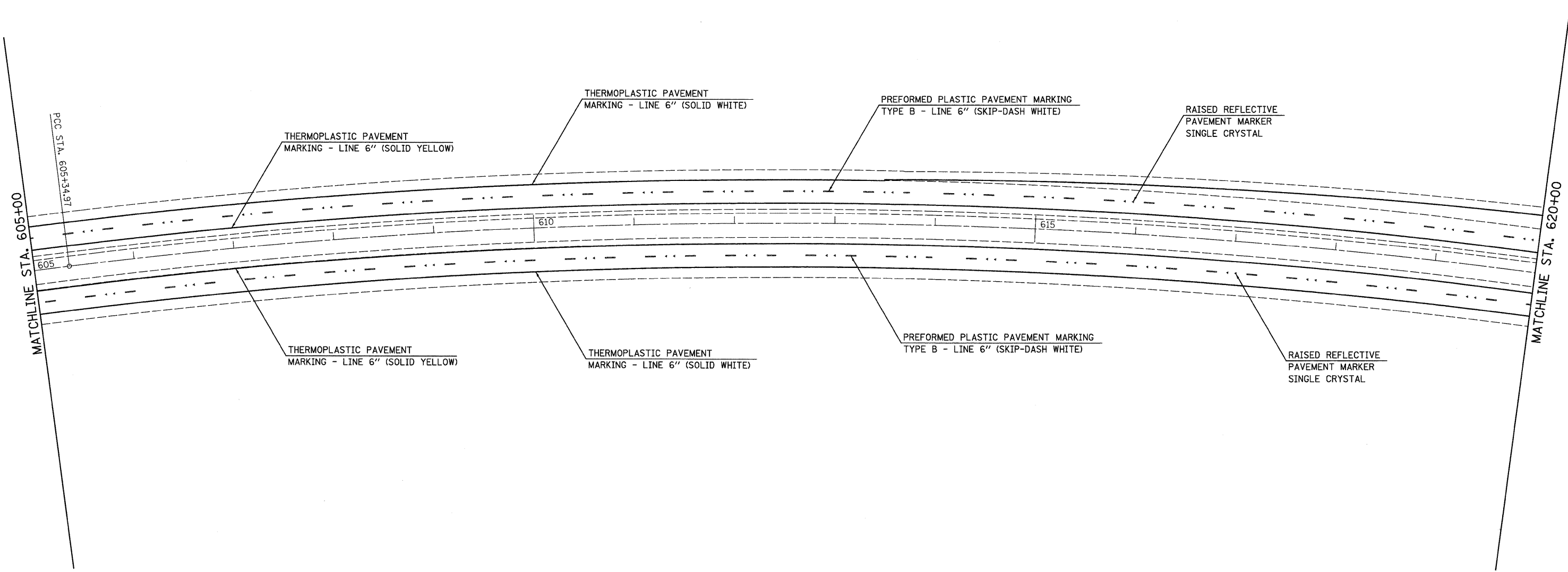

FILE NAME = ... \D876A73-eh-pmk04.dgn	USER NAME = SJS	DESIGNED -	REVISED -
Johnson, Depp & Gulesberry CONSULTING ENGINEERS Springfield, Illinois	PLOT SCALE = 50.0000' / IN.	DRAWN -	REVISED -
	PLOT DATE = 06/12/2009 09:27:05	CHECKED -	REVISED -
		DATE -	REVISED -

**STATE OF ILLINOIS  
DEPARTMENT OF TRANSPORTATION**

<b>F.A.I. ROUTE 70 PAVEMENT MARKING PLANS</b>			
SCALE: 1' = 50'	SHEET NO.	OF SHEETS	STA. 605+00 TO STA. 620+00

F.A.I. RTE. 70	SECTION •	COUNTY MADISON	TOTAL SHEETS 150	SHEET NO. 70
FED. ROAD DIST. NO. [ILLINOIS] FED. AID PROJECT			CONTRACT NO. 76A73	

• 60-(7,8,9,10)RS, 60-(8,9,10)BR

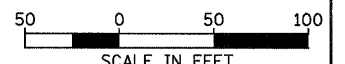
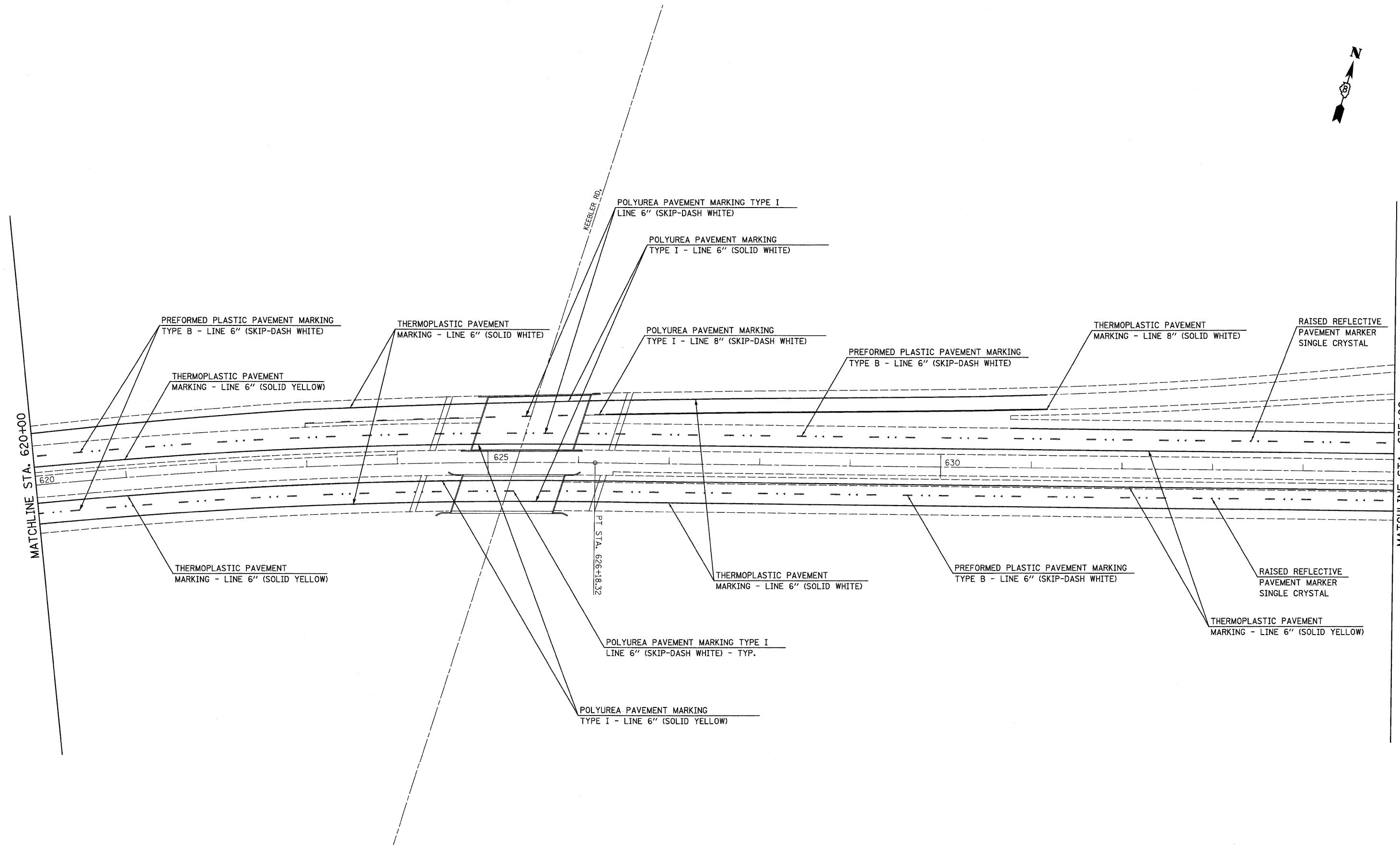

• 60-(7,8,9,10)RS, 60-(8,9,10)BR

FILE NAME = ... \0876A73-ehh-pmk05.dgn 	USER NAME = SJS DESIGNED - DRAWN - CHECKED - DATE -	REVISED - REVISED - REVISED - REVISED -	<b>STATE OF ILLINOIS DEPARTMENT OF TRANSPORTATION</b>	<b>F.A.I. ROUTE 70 PAVEMENT MARKING PLANS</b>		F.A.I. RTE. 70	SECTION *	COUNTY MADISON	TOTAL SHEETS 150	SHEET NO. 71
	PLOT SCALE = 5/8" = 1' IN. PLOT DATE = 06/12/2009 09:27:19	DATE -		SCALE: 1" = 50' SHEET NO. OF SHEETS STA. 620+00 TO STA. 635+00	CONTRACT NO. 76A73 FED. ROAD DIST. NO. ILLINOIS FED. AID PROJECT					

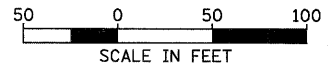
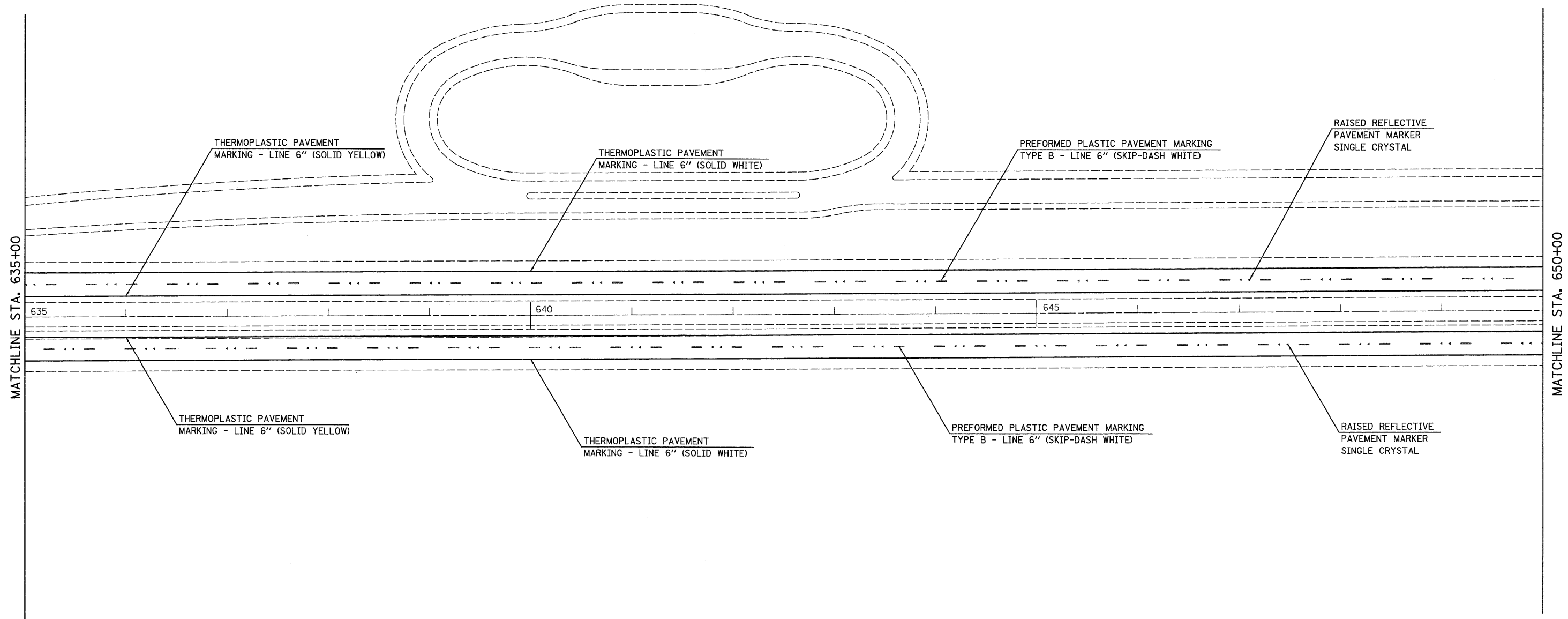

• 60-(7,8,9,10)RS, 60-(8,9,10)BR

FILE NAME = ...N0876A73-shr-pmk06.dgn 	USER NAME = SJS	DESIGNED -	REVISED -	<b>STATE OF ILLINOIS</b> <b>DEPARTMENT OF TRANSPORTATION</b>	<b>F.A.I. ROUTE 70</b> <b>PAVEMENT MARKING PLANS</b>		F.A.I. SECTION 70 *	COUNTY MADISON	TOTAL SHEETS 150	SHEET NO. 72
	PLOT SCALE = 50.0000' / IN.	CHECKED -	REVISED -		REVISED -	SCALE: 1' = 50'	SHEET NO. OF SHEETS	STA. 635+00 TO STA. 650+00	FED. ROAD DIST. NO. ILLINOIS FED. AID PROJECT	CONTRACT NO. 76A73
PLOT DATE = 06/12/2009 09:27:32	DATE -	REVISED -	REVISED -							

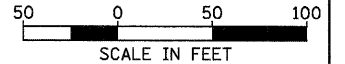
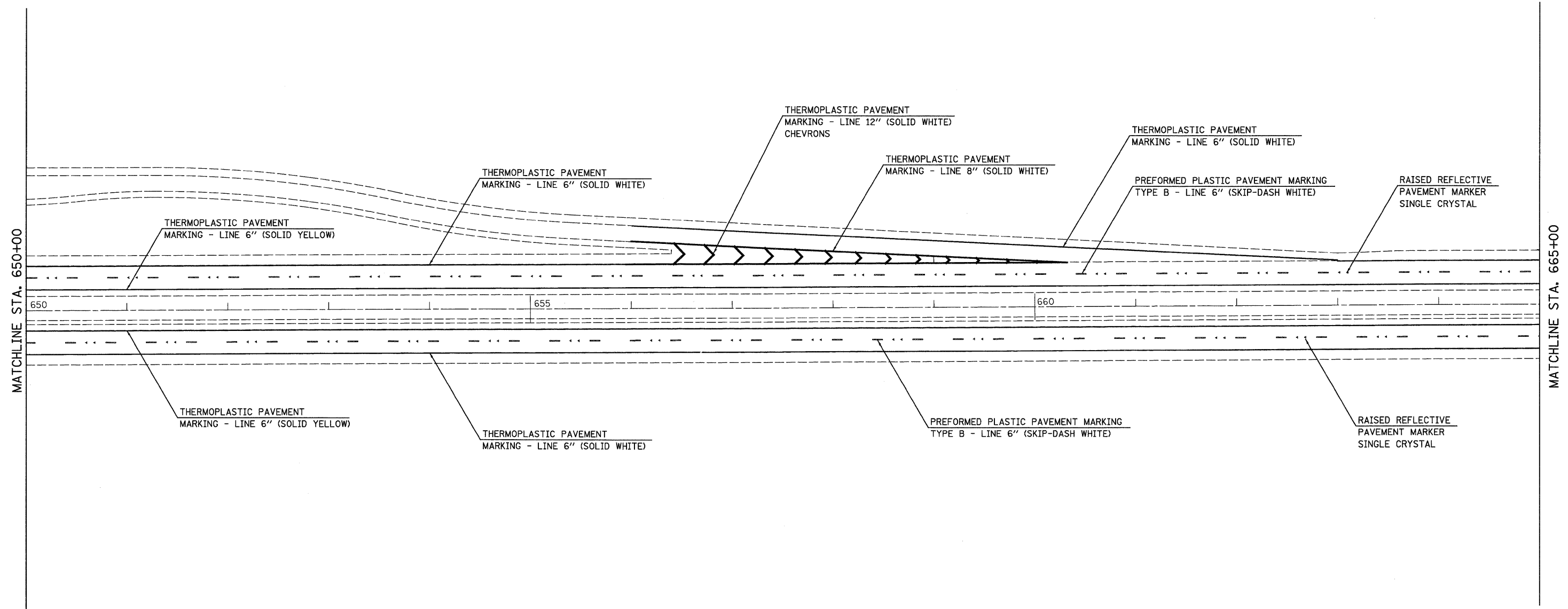

SCALE IN FEET  
• 60-(7,8,9,10)RS, 60-(8,9,10)BR

FILE NAME = ...D876A73-ahk-pmk07.dgn	USER NAME = SJS	DESIGNED -	REVISED -
Johnson, Depp & Oulsenberry CONSULTING ENGINEERS Springfield, Illinois	PLOT SCALE = 50.0000' / IN.	DRAWN -	REVISED -
	PLOT DATE = 06/12/2009 09:27:45	CHECKED -	REVISED -
		DATE -	REVISED -

**STATE OF ILLINOIS  
DEPARTMENT OF TRANSPORTATION**

<b>F.A.I. ROUTE 70 PAVEMENT MARKING PLANS</b>			
SCALE: 1' = 50'	SHEET NO. OF SHEETS	STA. 650+00 TO STA. 665+00	

F.A.I. RTE. 70	SECTION *	COUNTY MADISON	TOTAL SHEETS 150	SHEET NO. 73
FED. ROAD DIST. NO.		ILLINOIS FED. AID PROJECT		
		CONTRACT NO. 76A73		

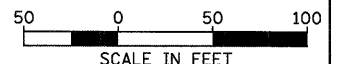
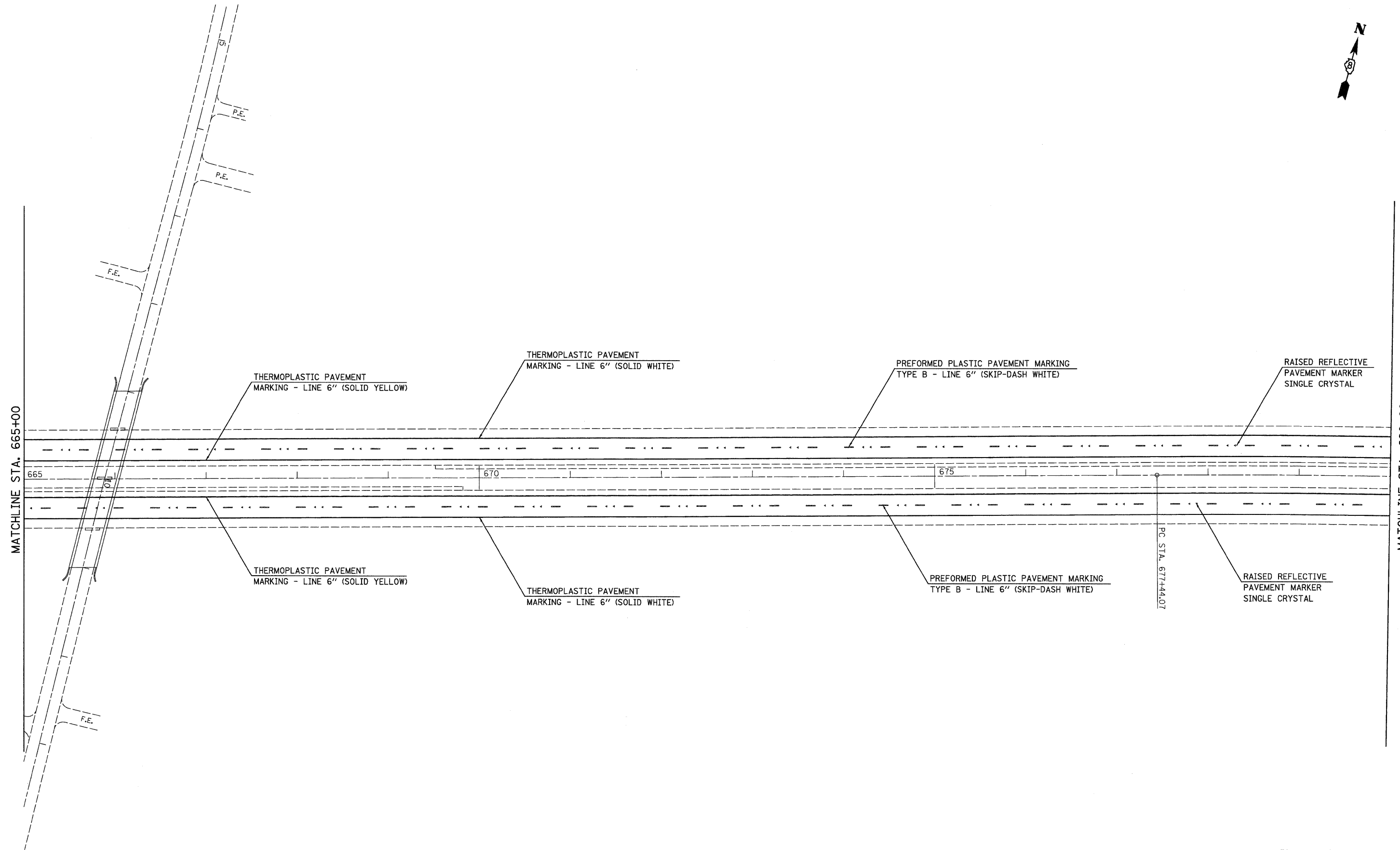

• 60-(7,8,9,10)RS, 60-(8,9,10)BR

FILE NAME = ...\\0876A73-eh-t-pmk88.dgn	USER NAME = SJS	DESIGNED -	REVISED -
	PLOT SCALE = 50.0000' / IN.	DRAWN -	REVISED -
	PLOT DATE = 06/12/2009 09:27:58	CHECKED -	REVISED -
		DATE -	REVISED -

**STATE OF ILLINOIS  
DEPARTMENT OF TRANSPORTATION**

<b>F.A.I. ROUTE 70 PAVEMENT MARKING PLANS</b>			
SCALE: 1' = 50'	SHEET NO. OF SHEETS	STA. 665+00 TO STA. 680+00	

F.A.I. RTE.	SECTION	COUNTY	TOTAL SHEETS	SHEET NO.
70		MADISON	150	74
FED. ROAD DIST. NO. ILLINOIS FED. AID PROJECT			CONTRACT NO. 76A73	



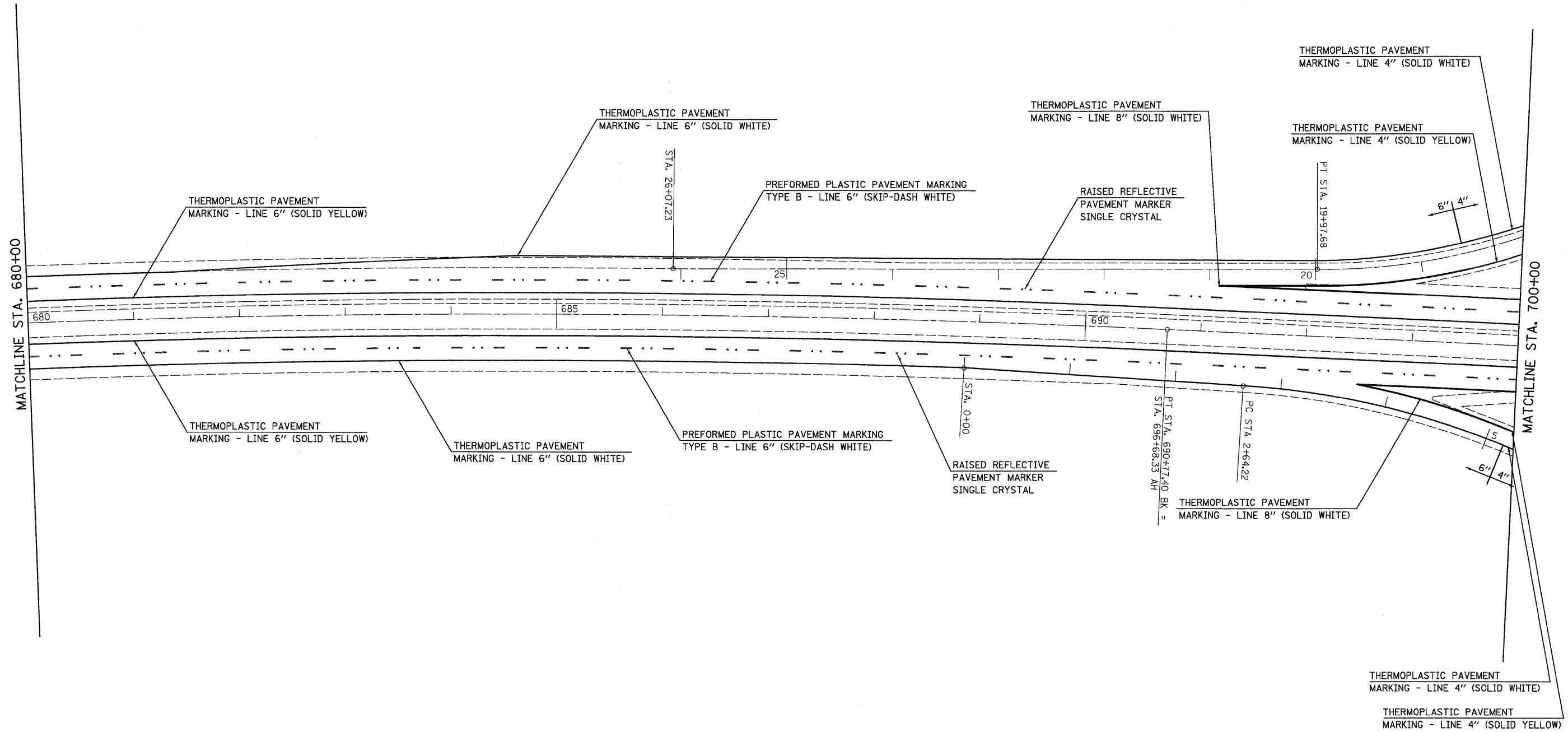

FILE NAME = ... \D876A73-ahh-pmk09.dgn	USER NAME = SJS	DESIGNED -	REVISED -
Johnson, Depp & Oulsenberry CONSULTING ENGINEERS Springfield, Illinois	PLOT SCALE = 50.0000' / IN.	DRAWN -	REVISED -
	PLOT DATE = 06/12/2009 09:28:11	CHECKED -	REVISED -
		DATE -	REVISED -

**STATE OF ILLINOIS  
DEPARTMENT OF TRANSPORTATION**

<b>F.A.I. ROUTE 70 PAVEMENT MARKING PLANS</b>			
SCALE: 1" = 50'	SHEET NO.	OF SHEETS	STA. 680+00 TO STA. 700+00

F.A.I. RTE. 70	SECTION •	COUNTY MADISON	TOTAL SHEETS 150	SHEET NO. 75
FED. ROAD DIST. NO.		ILLINOIS FED. AID PROJECT		

• 60-(7,8,9,10)RS, 60-(8,9,10)BR

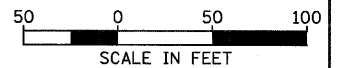

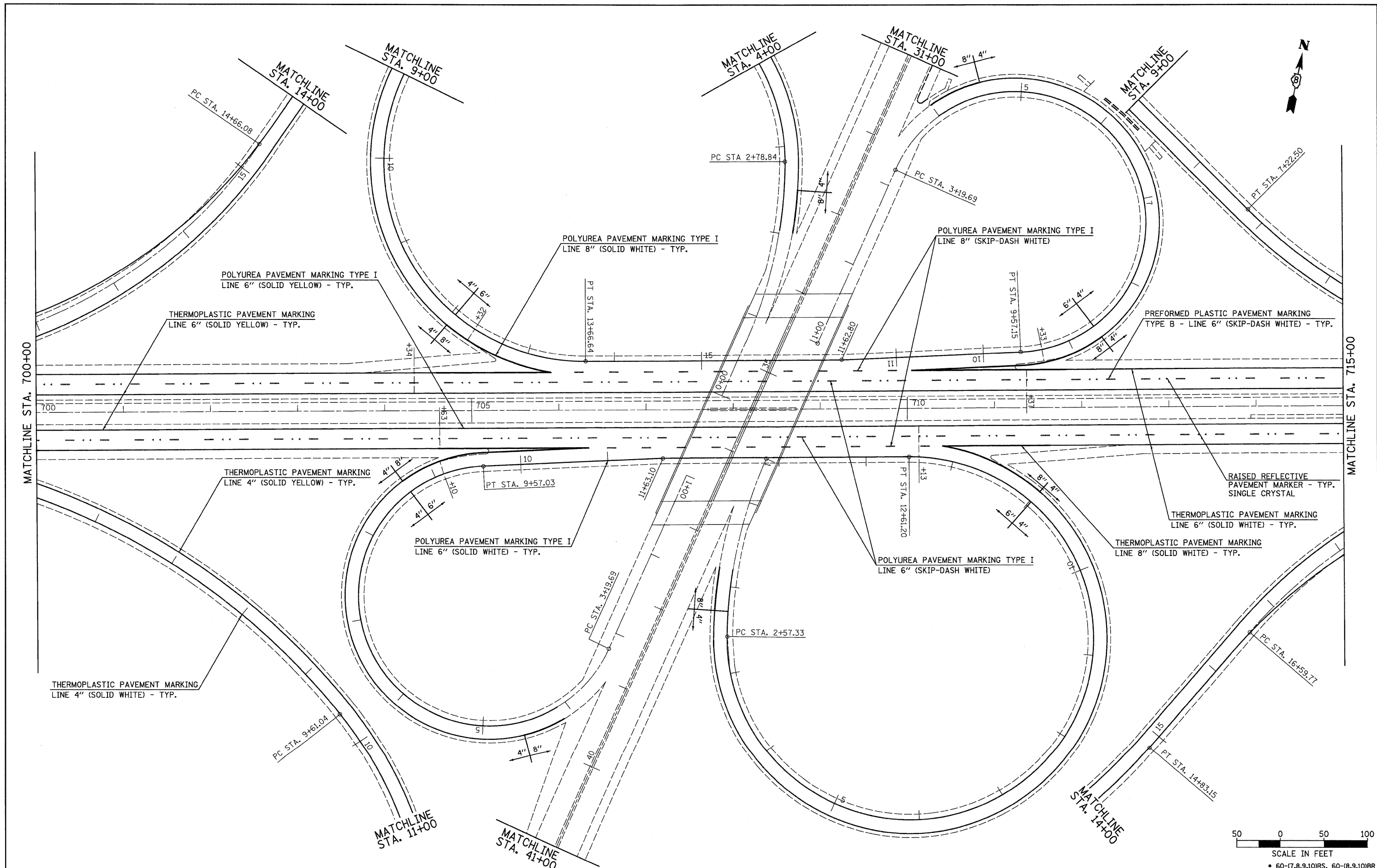

FILE NAME = ...\\0876A73-ahh-pmk10.dgn 	USER NAME = SJS	DESIGNED -	REVISED -	<b>STATE OF ILLINOIS</b> <b>DEPARTMENT OF TRANSPORTATION</b>	<b>F.A.I. ROUTE 70</b> <b>PAVEMENT MARKING PLANS</b>		F.A.I. RTE.	SECTION	COUNTY	TOTAL SHEETS	SHEET NO.
	PLOT SCALE = 5/8" = 1' / IN. PLOT DATE = 06/12/2009 09:28:24	DRAWN - CHECKED - DATE -	REVISED - REVISED - REVISED -		SCALE: 1" = 50' SHEET NO. OF SHEETS STA. 700+00 TO STA. 715+00	70	MADISON	150	76		
							CONTRACT NO. 76A73		FED. ROAD DIST. NO. ILLINOIS FED. AID PROJECT		

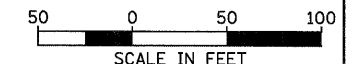
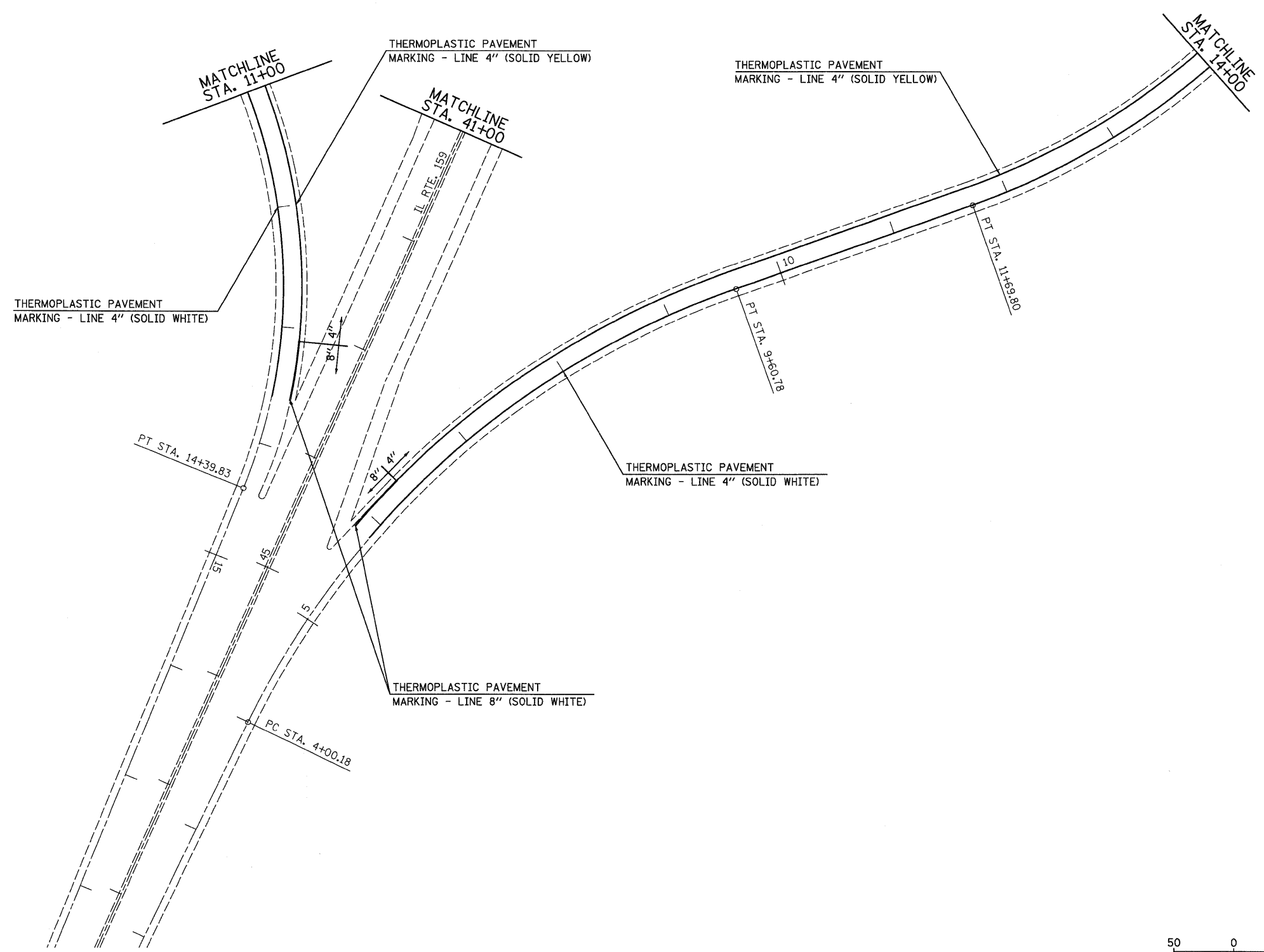

• 60-(7,8,9,10)RS, 60-(8,9,10)BR

FILE NAME = ...ND876A73-shd-pmk10a.dgn	USER NAME = SJS	DESIGNED -	REVISED -
Johnson, Depp & Oulsenberry CONSULTING ENGINEERS Springfield, Illinois	PLOT SCALE = 50.0000' / IN.	DRAWN -	REVISED -
	PLOT DATE = 06/12/2009 09:28:38	CHECKED -	REVISED -
		DATE -	REVISED -

**STATE OF ILLINOIS  
DEPARTMENT OF TRANSPORTATION**

**F.A.I. ROUTE 70  
PAVEMENT MARKING PLANS**

SCALE: 1" = 50' SHEET NO. OF SHEETS STA. TO STA.

F.A.I. RTE.	SECTION	COUNTY	TOTAL SHEETS	SHEET NO.
70	•	MADISON	150	77

CONTRACT NO. 76A73

FED. ROAD DIST. NO. ILLINOIS FED. AID PROJECT

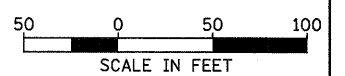
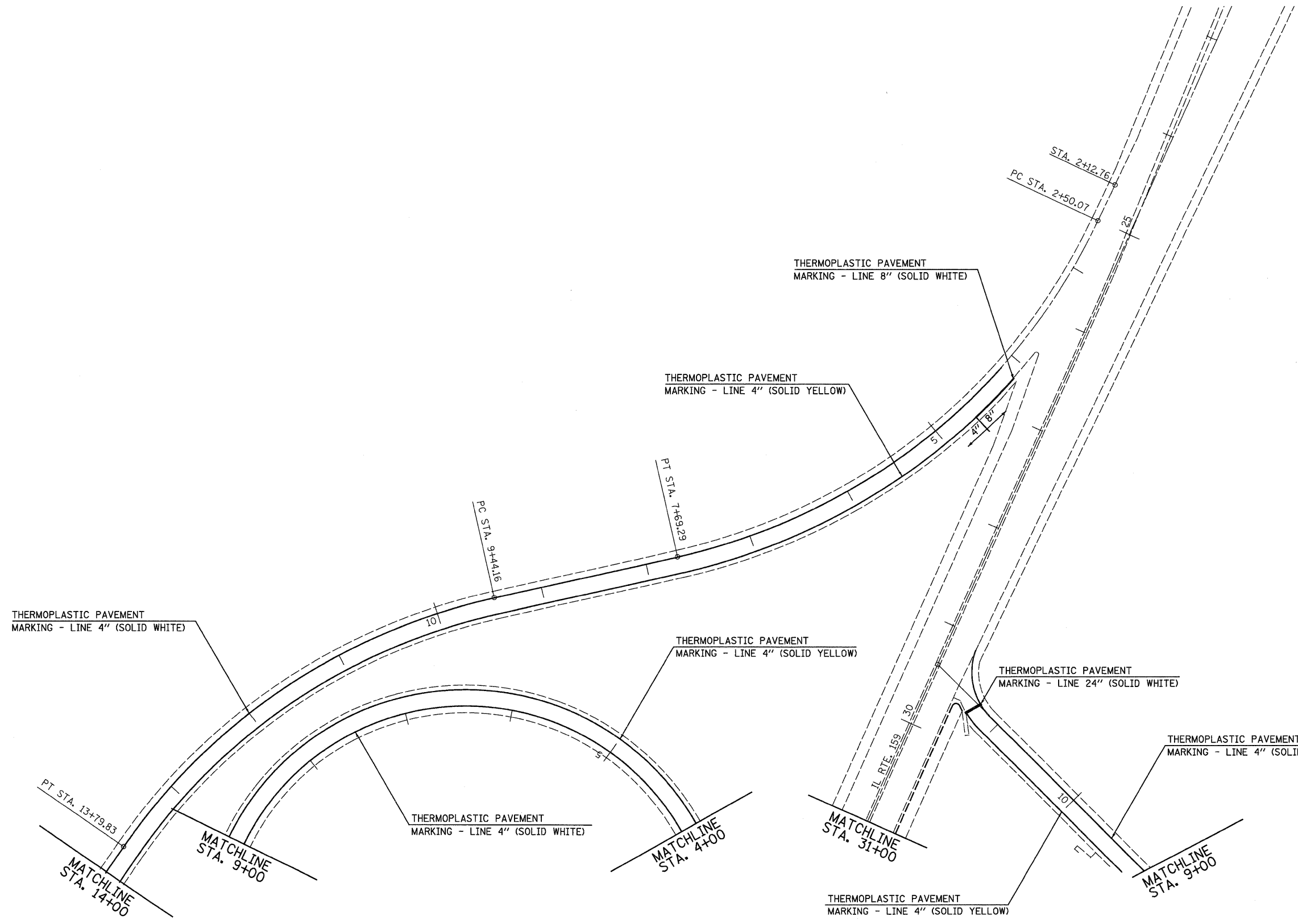

SCALE IN FEET

• 60-(7,8,9,10)RS, 60-(8,9,10)BR

FILE NAME = ... \0876A73-ehf-pmk10b.dgn	USER NAME = SJS	DESIGNED -	REVISED -
	PLOT SCALE = 50.0000' / IN.	DRAWN -	REVISED -
	PLOT DATE = 06/12/2009 09:28:51	CHECKED -	REVISED -
		DATE -	REVISED -

**STATE OF ILLINOIS  
DEPARTMENT OF TRANSPORTATION**

<b>F.A.I. ROUTE 70 PAVEMENT MARKING PLANS</b>			
SCALE: 1' = 50'	SHEET NO.	OF SHEETS	STA. TO STA.

F.A.I. RTE. 70	SECTION •	COUNTY MADISON	TOTAL SHEETS 150	SHEET NO. 78
FED. ROAD DIST. NO.		ILLINOIS FED. AID PROJECT		
		CONTRACT NO. 76A73		

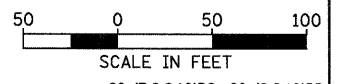
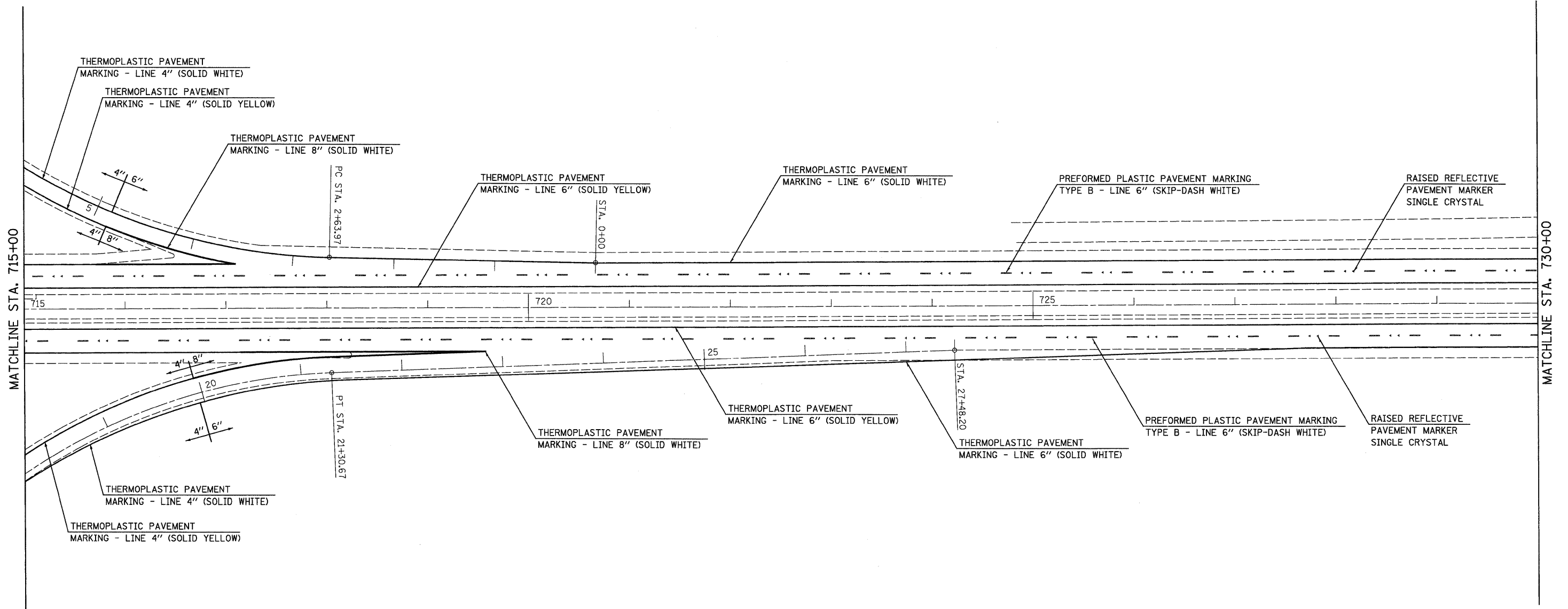

• 60-(7,8,9,10)RS, 60-(8,9,10)BR

FILE NAME = ...N0876A73-sht-pmk11.dgn 	USER NAME = SJS	DESIGNED -	REVISED -	<b>STATE OF ILLINOIS</b> <b>DEPARTMENT OF TRANSPORTATION</b>	<b>F.A.I. ROUTE 70</b> <b>PAVEMENT MARKING PLANS</b>		F.A.I. RTE.	SECTION	COUNTY	TOTAL SHEETS	SHEET NO.
	PLOT SCALE = 50.0000' / IN.	CHECKED -	REVISED -		TO		MADISON	150	79		
PLOT DATE = 06/12/2009 09:29:04	DATE -	REVISED -	REVISED -	SCALE: 1" = 50'	SHEET NO.	OF SHEETS	STA. 715+00	TO STA. 730+00	FED. ROAD DIST. NO.	ILLINOIS FED. AID PROJECT	CONTRACT NO. 76A73

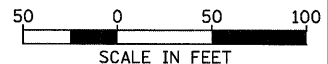
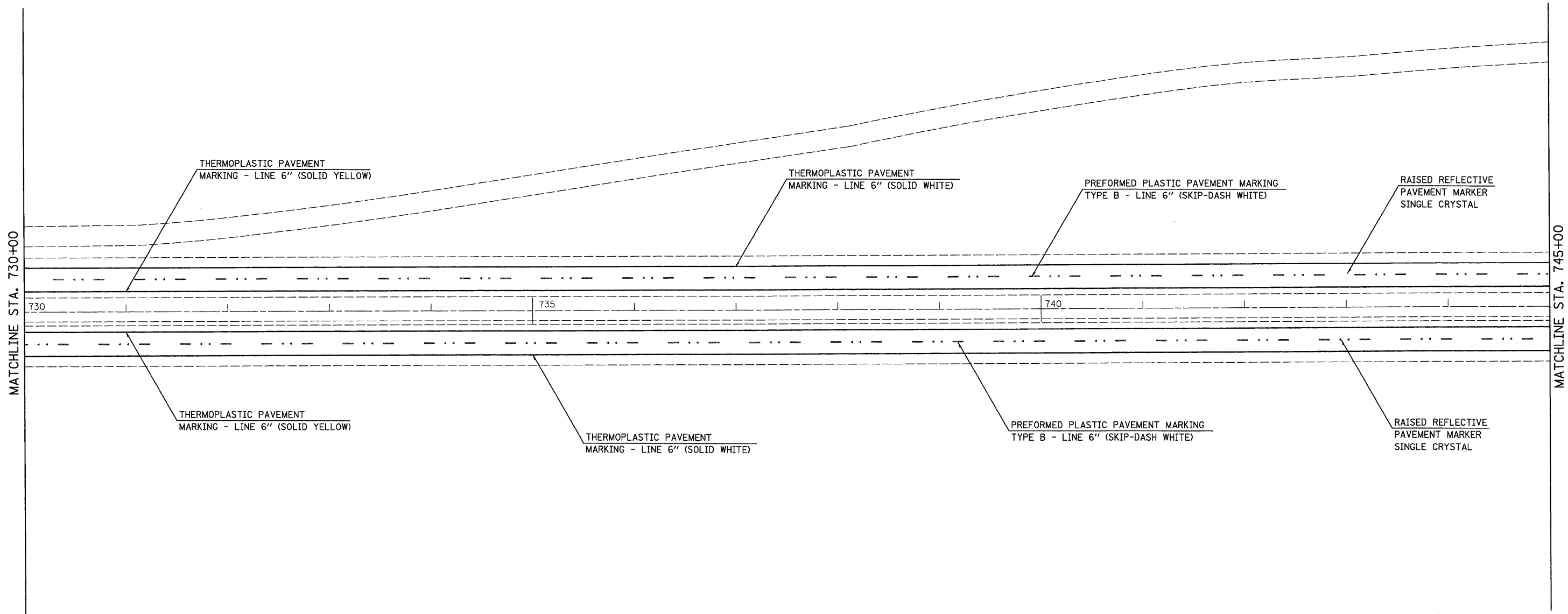

FILE NAME = ...\\0876A73-sht-pmk12.dgn  
**Johnson, Depp & Oulsenberry**  
 CONSULTING ENGINEERS  
 Springfield, Illinois

USER NAME = SJS  
 PLOT SCALE = 50.0000' / IN.  
 PLOT DATE = 06/12/2009 09:29:16

DESIGNED -	REVISED -
DRAWN -	REVISED -
CHECKED -	REVISED -
DATE -	REVISED -

**STATE OF ILLINOIS  
 DEPARTMENT OF TRANSPORTATION**

**F.A.I. ROUTE 70  
 PAVEMENT MARKING PLANS**

SCALE: 1' = 50'    SHEET NO.    OF    SHEETS    STA. 730+00    TO    STA. 745+00

F.A.I. RTE.	SECTION	COUNTY	TOTAL SHEETS	SHEET NO.
70	*	MADISON	150	80
FED. ROAD DIST. NO. ILLINOIS FED. AID PROJECT			CONTRACT NO. 76A73	

\* 60-(7,8,9,10)RS, 60-(8,9,10)BR

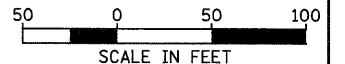
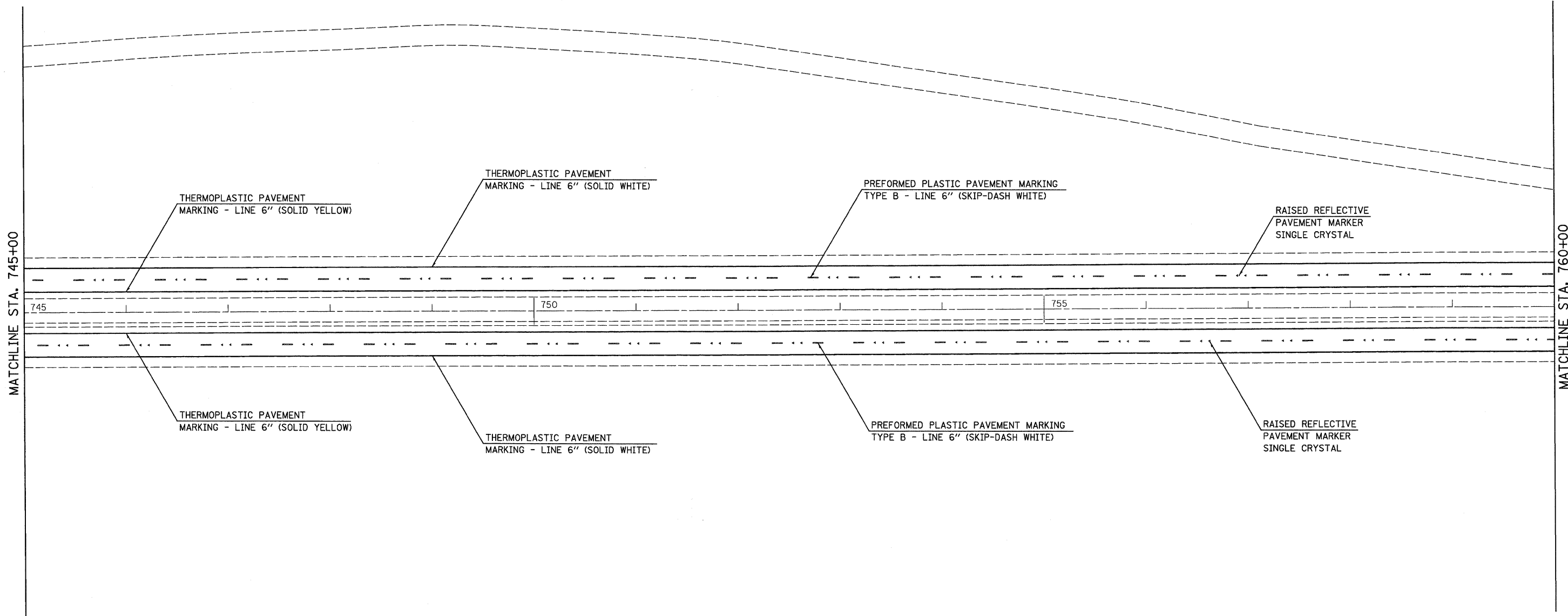

SCALE IN FEET  
• 60-(7,8,9,10)RS, 60-(8,9,10)BR

FILE NAME = ...D876A73-shd-pmk13.dgn 	USER NAME = SJS	DESIGNED -	REVISED -	<b>STATE OF ILLINOIS</b> <b>DEPARTMENT OF TRANSPORTATION</b>	<b>F.A.I. ROUTE 70</b> <b>PAVEMENT MARKING PLANS</b>	F.A.I. RTE. 70	SECTION •	COUNTY MADISON	TOTAL SHEETS 150	SHEET NO. 81
	PLOT SCALE = 50.0000' / IN.	CHECKED -	REVISED -			CONTRACT NO. 76A73	FED. ROAD DIST. NO.	ILLINOIS FED. AID PROJECT		
	PLOT DATE = 06/12/2009 09:29:28	DATE -	REVISED -		SCALE: 1' = 50'	SHEET NO.	OF	SHEETS	STA. 745+00	TO STA. 760+00

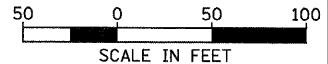
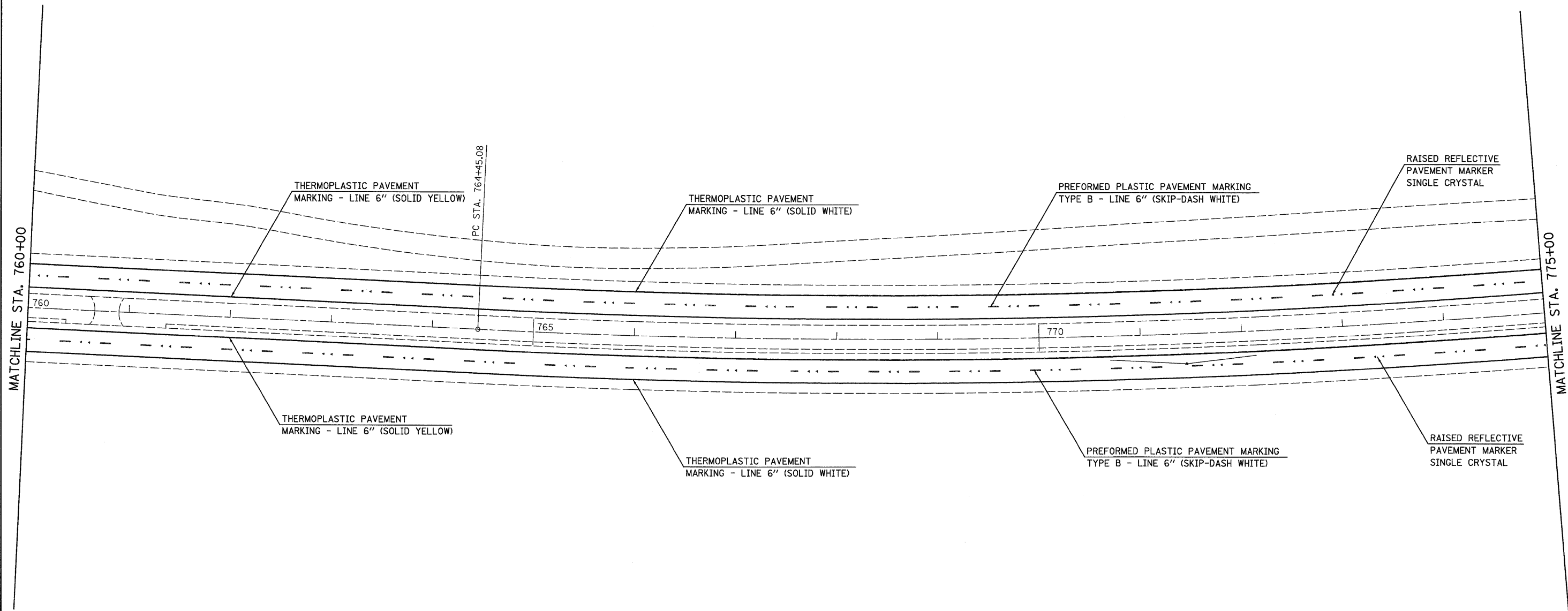

SCALE IN FEET  
• 60-(7,8,9,10)RS, 60-(8,9,10)BR

FILE NAME = ...\\D876A73-ehh\pmk14.dgn 	USER NAME = SJS	DESIGNED -	REVISED -	<b>STATE OF ILLINOIS DEPARTMENT OF TRANSPORTATION</b>	<b>F.A.I. ROUTE 70 PAVEMENT MARKING PLANS</b>	F.A.I. RTE. 70	SECTION •	COUNTY MADISON	TOTAL SHEETS 150	SHEET NO. 82
	PLOT SCALE = 50.0000' / IN. PLOT DATE = 06/12/2009 09:29:41	CHECKED -	REVISED -			SCALE: 1' = 50'	SHEET NO. OF SHEETS	STA. 760+00 TO STA. 775+00	FED. ROAD DIST. NO. [ILLINOIS] FED. AID PROJECT	CONTRACT NO. 76A73



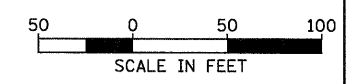
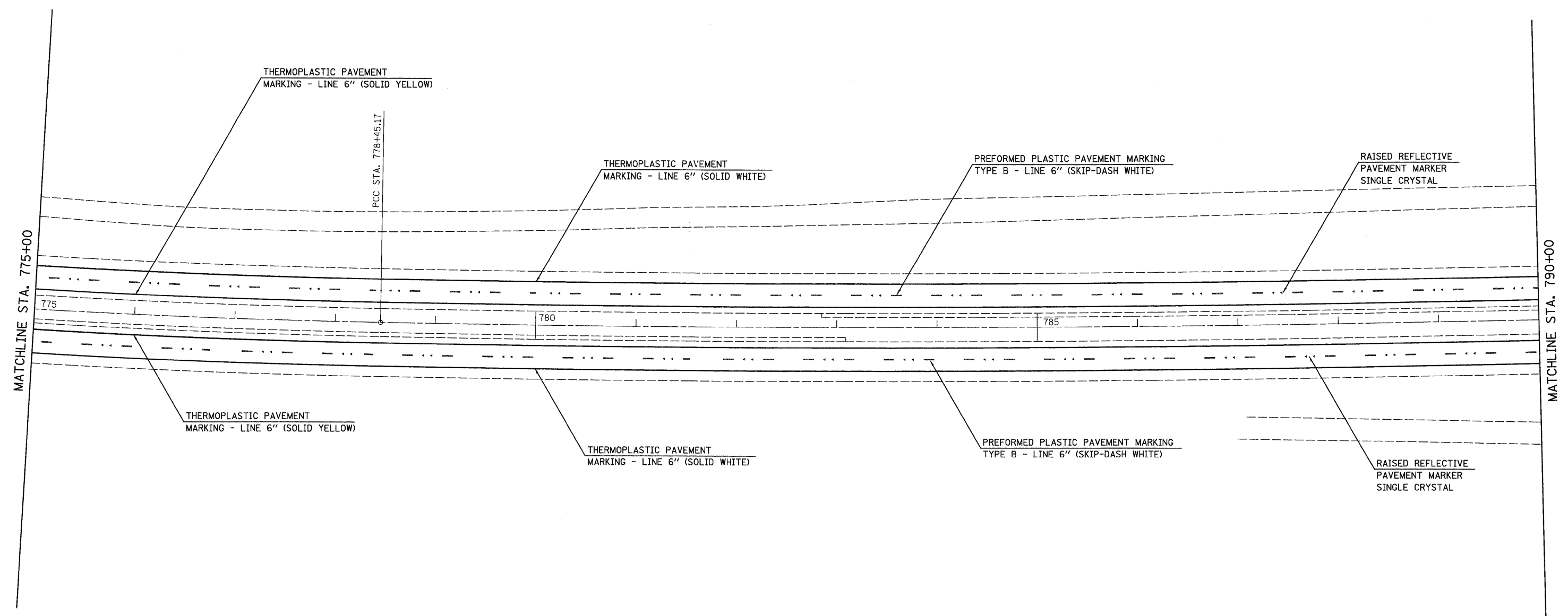

FILE NAME = ...D0876A73-ahk-pmk15.dgn 	USER NAME = SJS	DESIGNED -	REVISED -	<b>STATE OF ILLINOIS</b> <b>DEPARTMENT OF TRANSPORTATION</b>	<b>F.A.I. ROUTE 70</b> <b>PAVEMENT MARKING PLANS</b>			F.A.I. RTE. TO	SECTION *	COUNTY MADISON	TOTAL SHEETS 150	SHEET NO. 83
	PLOT SCALE = 50.0000' / IN. PLOT DATE = 06/12/2009 09:29:54	CHECKED -	REVISED -		REVISED -	SCALE: 1' = 50'	SHEET NO. OF SHEETS	STA. 775+00 TO STA. 790+00	FED. ROAD DIST. NO.	ILLINOIS FED. AID PROJECT	CONTRACT NO. 76A73	

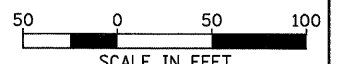
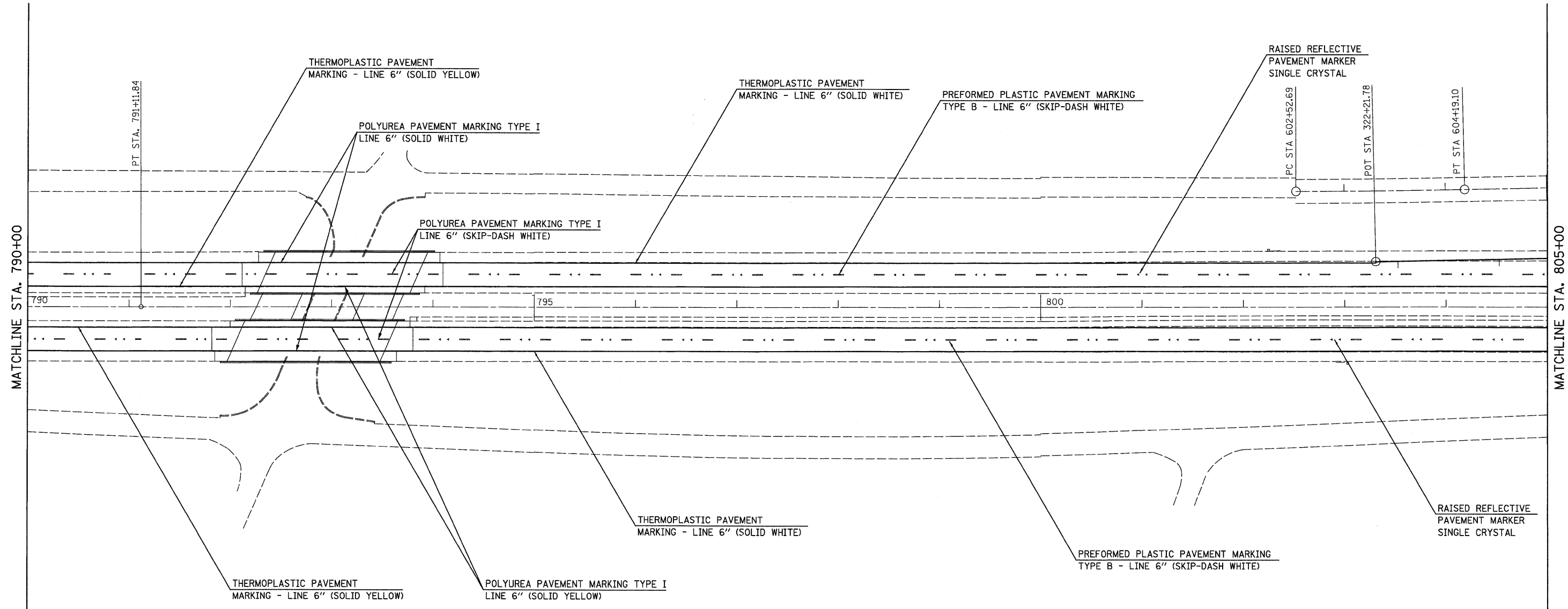

• 60-(7,8,9,10)RS, 60-(8,9,10)BR

FILE NAME =  
 ...\\0876A73-sht-pmk16.dgn  
**Johnson, Depp & Quisenberry**  
 CONSULTING ENGINEERS  
 Springfield, Illinois

USER NAME = SJS  
 PLOT SCALE = 50.0000' / IN.  
 PLOT DATE = 06/12/2009 09:30:07

DESIGNED -  
 DRAWN -  
 CHECKED -  
 DATE -

REVISED -  
 REVISED -  
 REVISED -  
 REVISED -

**STATE OF ILLINOIS  
 DEPARTMENT OF TRANSPORTATION**

**F.A.I. ROUTE 70  
 PAVEMENT MARKING PLANS**

SCALE: 1" = 50'    SHEET NO.    OF    SHEETS    STA. 790+00    TO STA. 805+00

F.A.I. RTE.	SECTION	COUNTY	TOTAL SHEETS	SHEET NO.
70		MADISON	150	84
CONTRACT NO. 76A73			FED. ROAD DIST. NO.    ILLINOIS FED. AID PROJECT	

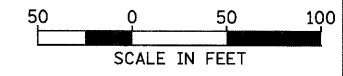
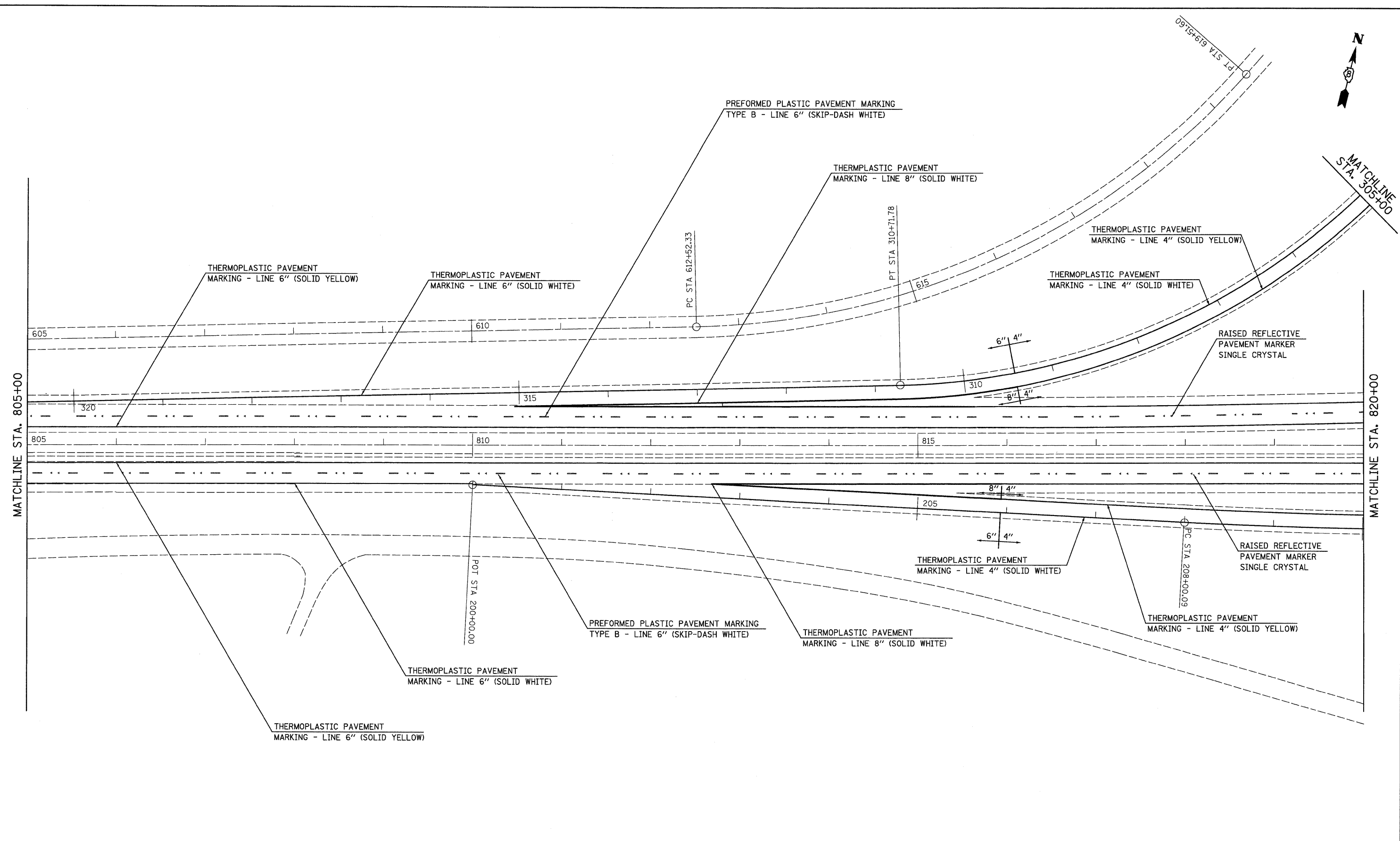

FILE NAME =  
 ...N0876A73-shd-pmk17.dgn  

 Johnson, Depp & Quisenberry  
 CONSULTING ENGINEERS  
 Springfield, Illinois

USER NAME = SJS  
 PLOT SCALE = 50.0000' / IN.  
 PLOT DATE = 06/12/2009 09:30:20

DESIGNED -  
 DRAWN -  
 CHECKED -  
 DATE -

REVISED -  
 REVISED -  
 REVISED -  
 REVISED -

**STATE OF ILLINOIS  
 DEPARTMENT OF TRANSPORTATION**

**F.A.I. ROUTE 70  
 PAVEMENT MARKING PLANS**

SCALE: 1" = 50'    SHEET NO.    OF    SHEETS    STA. 805+00    TO STA. 820+00

F.A.I. RTE. 70	SECTION .	COUNTY MADISON	TOTAL SHEETS 150	SHEET NO. 85
FED. ROAD DIST. NO.		ILLINOIS FED. AID PROJECT		
CONTRACT NO. 76A73				

• 60-(7,8,9,10)RS, 60-(8,9,10)BR

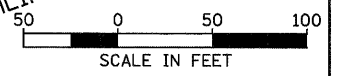
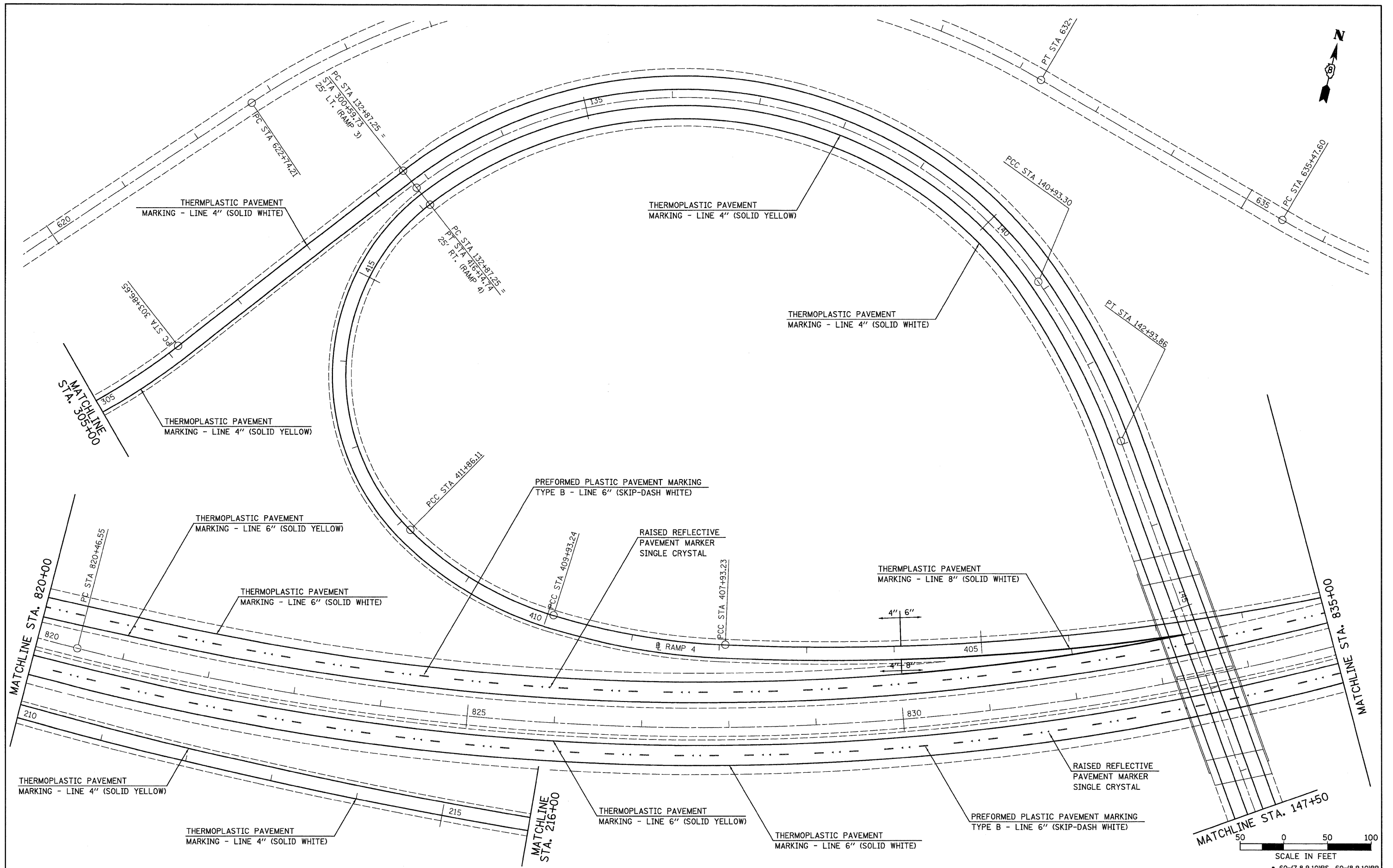

FILE NAME = ...\\0878A73-shr-pmk18.dgn 	USER NAME = SJS	DESIGNED -	REVISED -	<b>STATE OF ILLINOIS</b> <b>DEPARTMENT OF TRANSPORTATION</b>	<b>F.A.I. ROUTE 70</b> <b>PAVEMENT MARKING PLANS</b>		F.A.I. RTE. 70	SECTION	COUNTY MADISON	TOTAL SHEETS 150	SHEET NO. 86
	PLOT SCALE = 50.0000' / IN. PLOT DATE = 06/12/2009 09:30:33	CHECKED -	REVISED -		REVISED -	SCALE: 1' = 50'	SHEET NO. OF SHEETS	STA. 820+00 TO STA. 835+00	FED. ROAD DIST. NO. ILLINOIS FED. AID PROJECT	CONTRACT NO. 76A73	

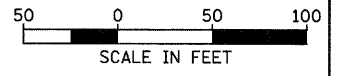
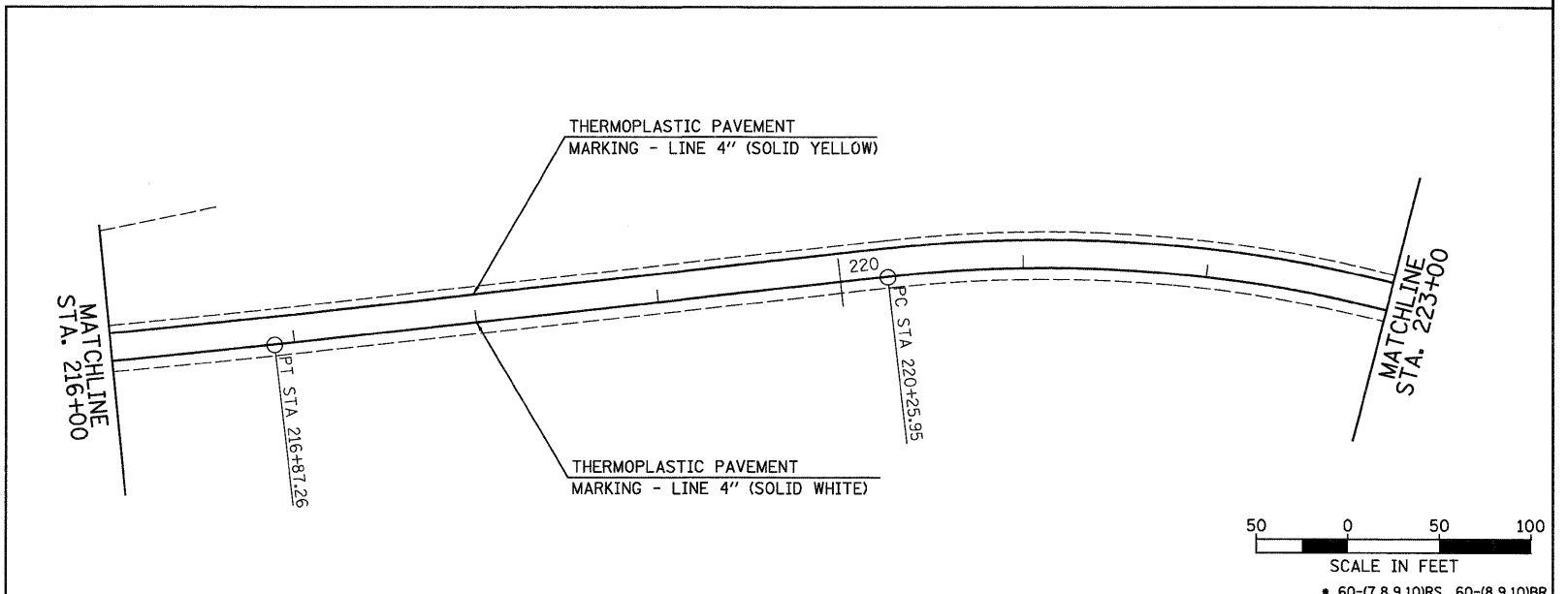
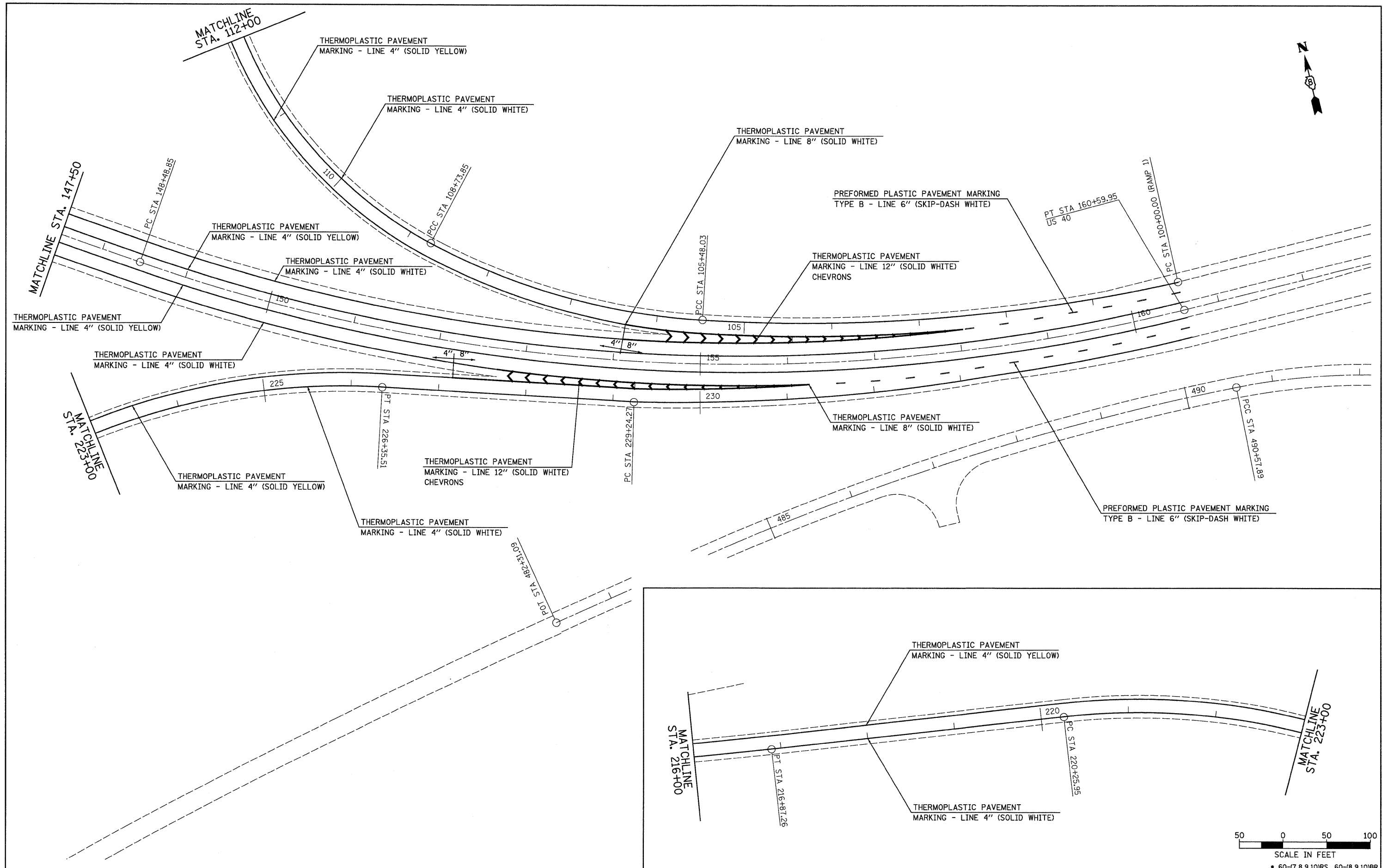

FILE NAME = ...\\0876A73-ahh-pmk18a.dgn 	USER NAME = SJS	DESIGNED -	REVISED -	<b>STATE OF ILLINOIS</b> <b>DEPARTMENT OF TRANSPORTATION</b>	<b>F.A.I. ROUTE 70</b> <b>PAVEMENT MARKING PLANS</b>			F.A.I. RTE. 70	SECTION	COUNTY MADISON	TOTAL SHEETS 150	SHEET NO. 87
	PLOT SCALE = 50.0000' / IN. PLOT DATE = 06/12/2009 09:30:48	DRAWN - CHECKED - DATE -	REVISED - REVISED - REVISED -		SCALE: 1" = 50' SHEET NO. OF SHEETS STA. 147+50 TO STA. 162+00	FED. ROAD DIST. NO. ILLINOIS FED. AID PROJECT	CONTRACT NO. 76A73					

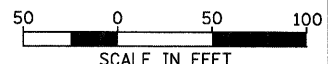
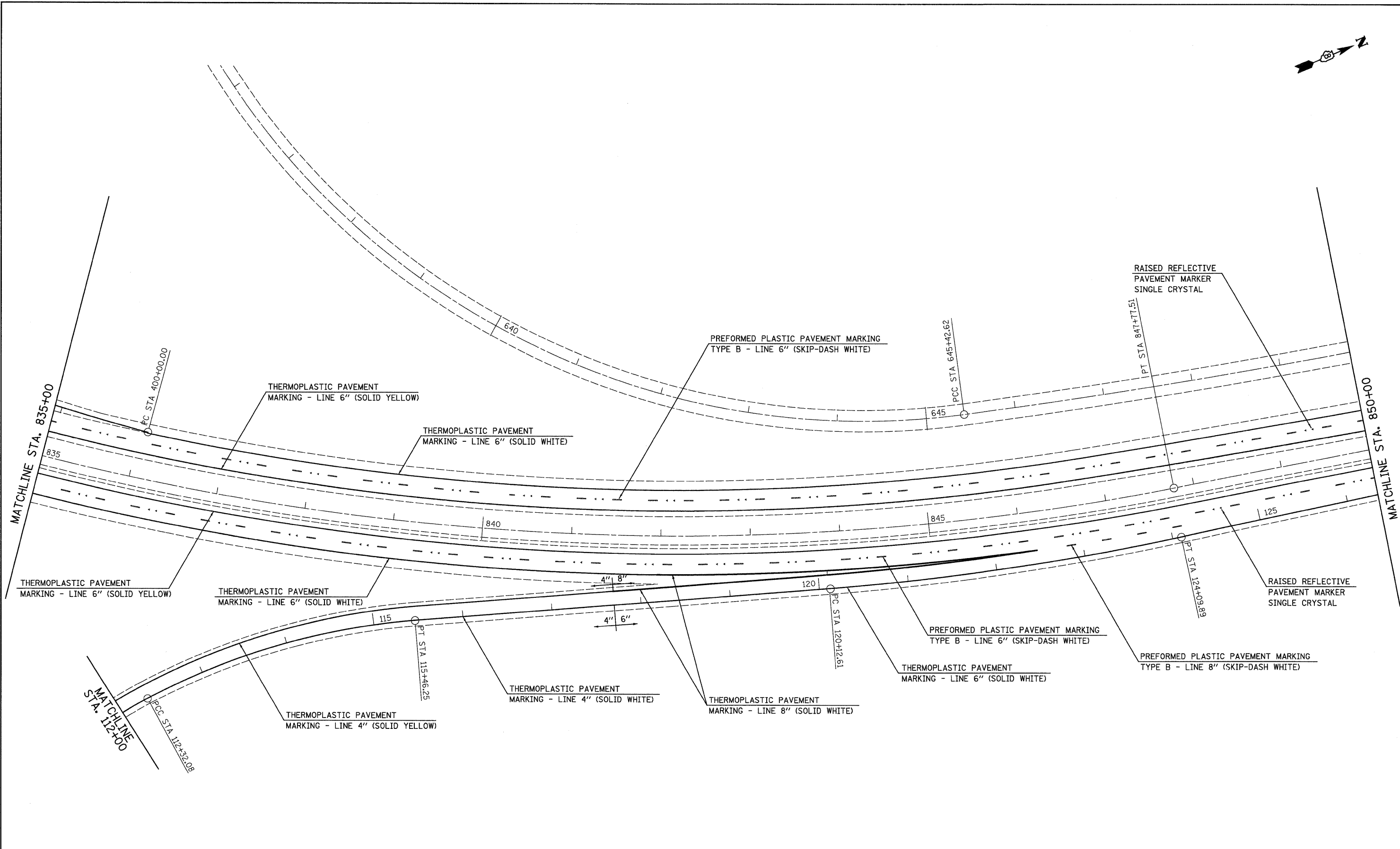

• 60-(7,8,9,10)RS, 60-(8,9,10)BR

FILE NAME =  
 ...N0876A73-sht-pmk19.dgn  
**Johnson, Depp & Gilsenberry**  
 CONSULTING ENGINEERS  
 Springfield, Illinois

USER NAME = SJS  
 PLOT SCALE = 50.0000' / IN.  
 PLOT DATE = 06/12/2009 09:31:02

DESIGNED -  
 DRAWN -  
 CHECKED -  
 DATE -

REVISED -  
 REVISED -  
 REVISED -  
 REVISED -

**STATE OF ILLINOIS  
 DEPARTMENT OF TRANSPORTATION**

**F.A.I. ROUTE 70  
 PAVEMENT MARKING PLANS**  
 SCALE: 1" = 50' SHEET NO. OF SHEETS STA. 835+00 TO STA. 850+00

F.A.I. RTE.	SECTION	COUNTY	TOTAL SHEETS	SHEET NO.
70	*	MADISON	150	88

CONTRACT NO. 76A73  
 FED. ROAD DIST. NO. ILLINOIS FED. AID PROJECT

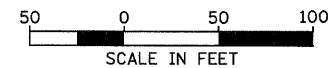
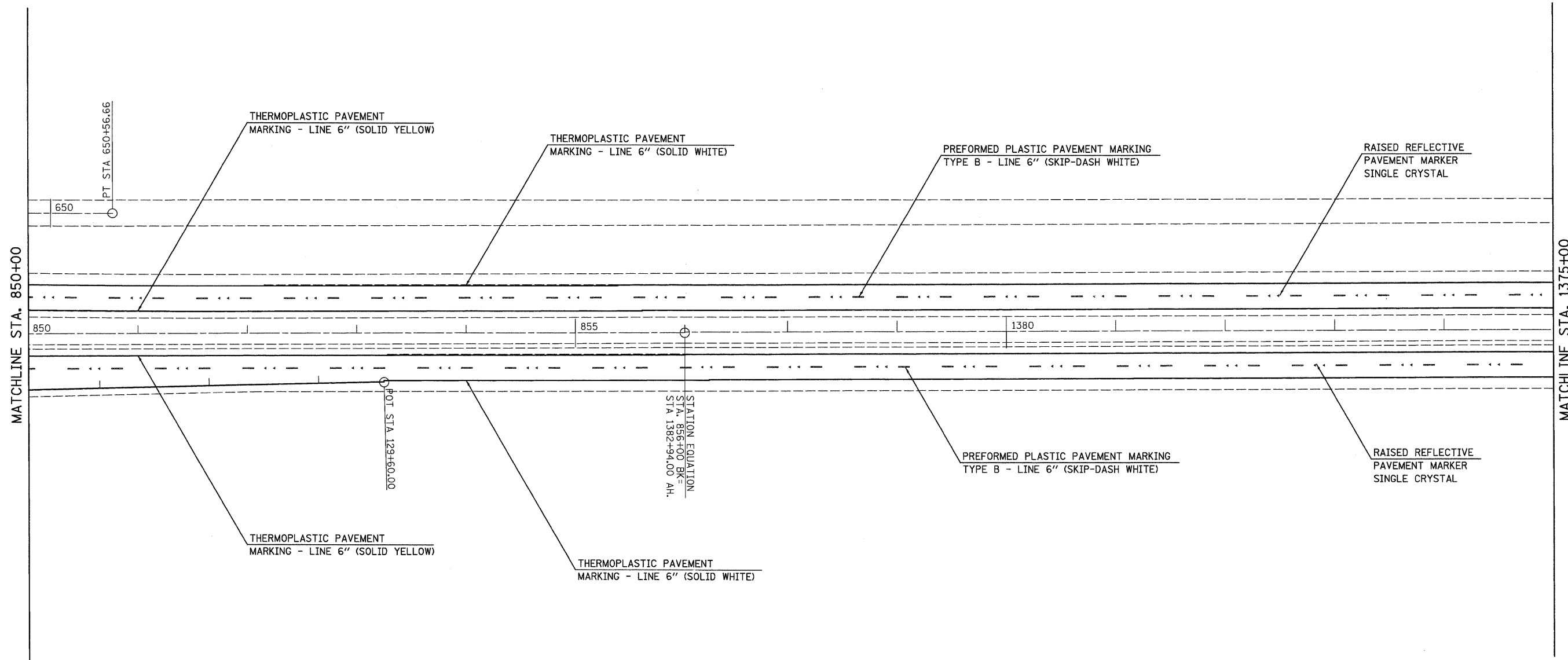

• 60-(7,8,9,10)RS, 60-(8,9,10)BR

FILE NAME = ...\\0876A73-shh-pmk20.dgn 	USER NAME = SJS	DESIGNED -	REVISED -	<b>STATE OF ILLINOIS</b> <b>DEPARTMENT OF TRANSPORTATION</b>	<b>F.A.I. ROUTE 70</b> <b>PAVMENT MARKING PLANS</b>			F.A.I. RTE. TO	SECTION *	COUNTY MADISON	TOTAL SHEETS /50	SHEET NO. 89
	PLOT SCALE = 50.0000' / IN. PLOT DATE = 06/12/2009 09:31:16	CHECKED -	REVISED -		REVISED -	SCALE: 1' = 50'	SHEET NO. OF SHEETS	STA. 850+00 TO STA. 1375+00	FED. ROAD DIST. NO.	ILLINOIS FED. AID PROJECT	CONTRACT NO. 76A73	

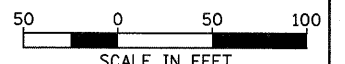
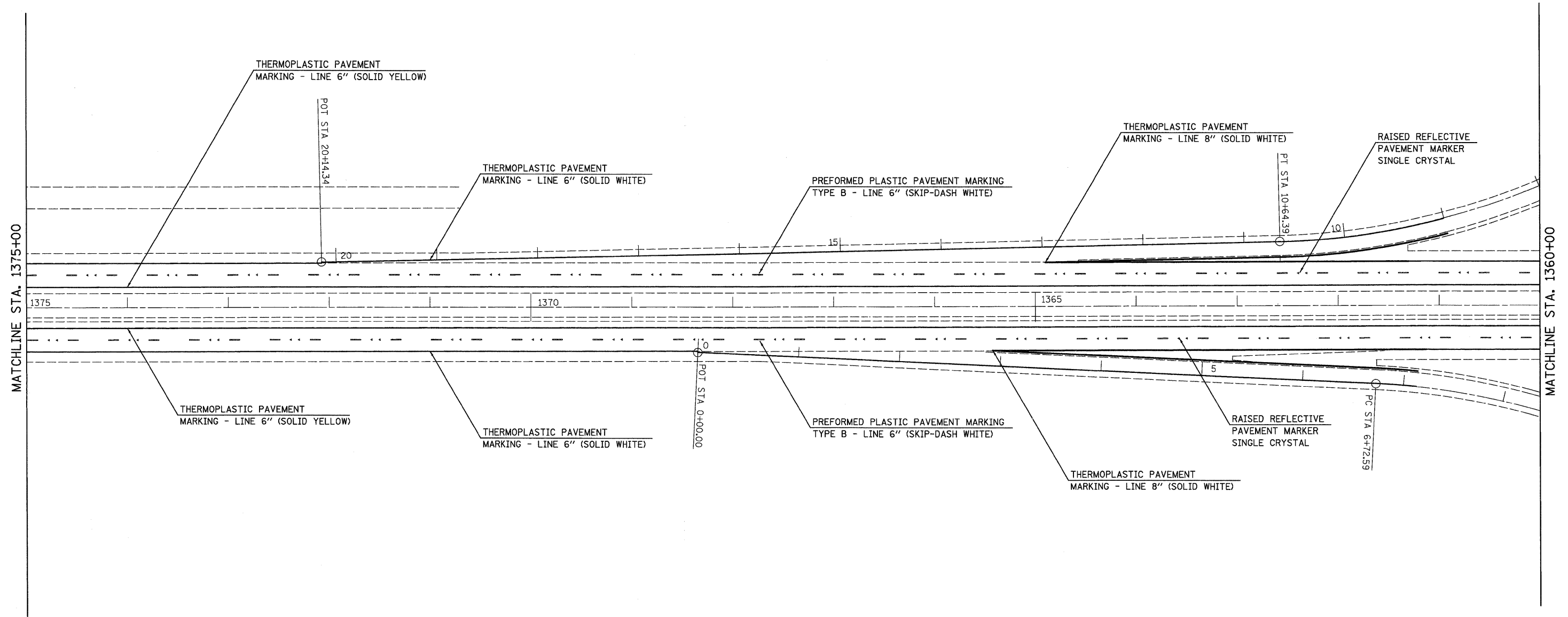

SCALE IN FEET  
• 60-(7,8,9,10)RS, 60-(8,9,10)BR

FILE NAME =  
...N0876A73-sht-pmk21.dgn  
**Johnson, Depp & Quisenberry**  
CONSULTING ENGINEERS  
Springfield, Illinois

USER NAME = SJS  
DESIGNED -  
DRAWN -  
CHECKED -  
DATE -  
PLOT SCALE = 50.0000' / IN.  
PLOT DATE = 06/12/2009 09:31:29

REVISOR -  
REVISION -  
REVISION -  
REVISION -

**STATE OF ILLINOIS  
DEPARTMENT OF TRANSPORTATION**

**F.A.I. ROUTE 70  
PAVEMENT MARKING PLANS**  
SCALE: 1" = 50'  
SHEET NO. OF SHEETS STA. 1375+00 TO STA. 1360+00

F.A.I. RTE.	SECTION	COUNTY	TOTAL SHEETS	SHEET NO.
70		MADISON	150	90
FED. ROAD DIST. NO. ILLINOIS FED. AID PROJECT			CONTRACT NO. 76A73	





MATCHLINE STA. 1360+00

MATCHLINE STA. 1345+00

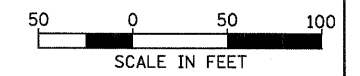
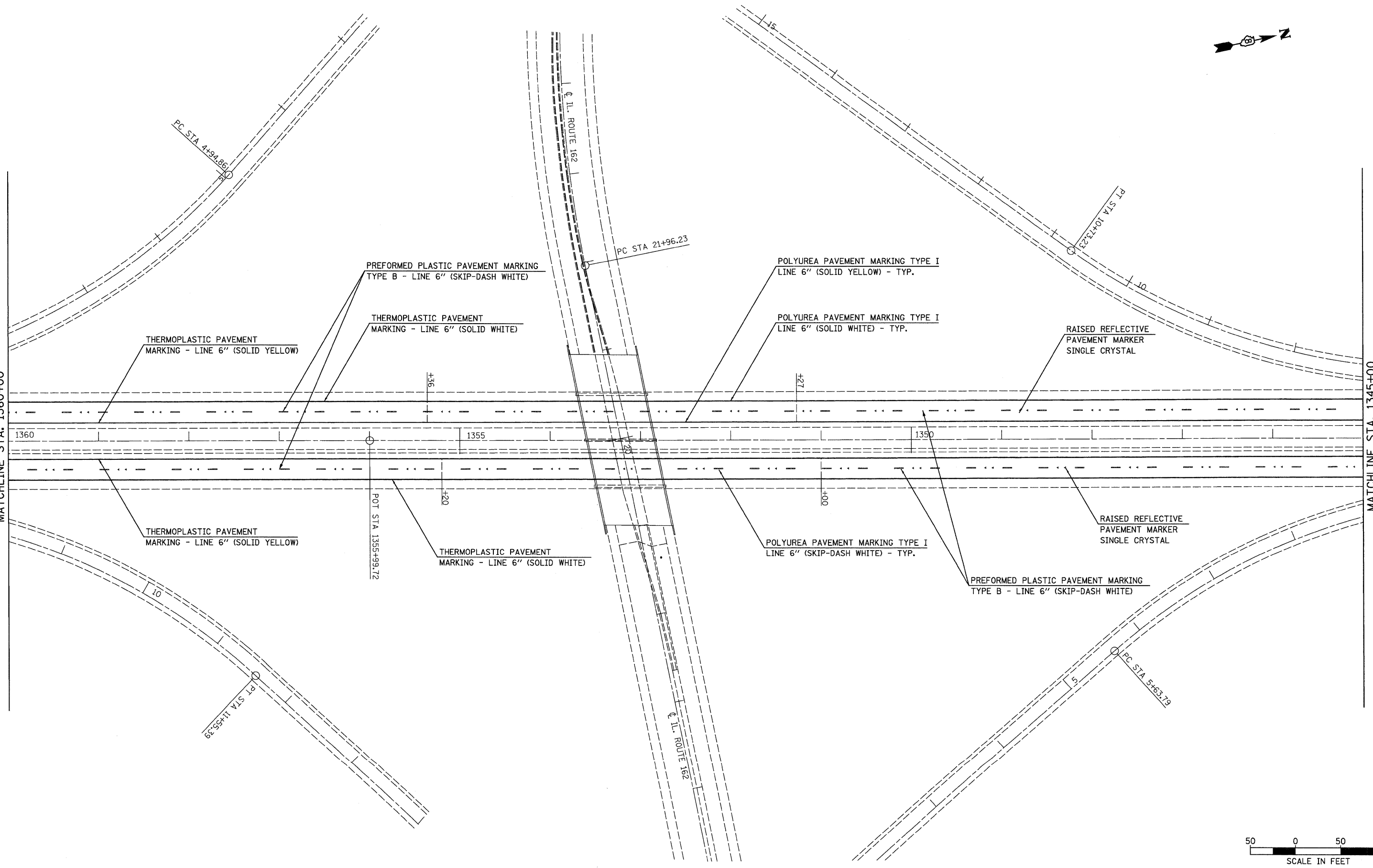

FILE NAME = ... \D878A73-sht-pmk22.dgn	USER NAME = SJS	DESIGNED -	REVISED -
Johnson, Depp & Oulsenberry CONSULTING ENGINEERS Springfield, Illinois	PLOT SCALE = 5/8" = 1' / IN.	DRAWN -	REVISED -
	PLOT DATE = 06/12/2009 09:31:41	CHECKED -	REVISED -
		DATE -	REVISED -

**STATE OF ILLINOIS  
DEPARTMENT OF TRANSPORTATION**

<b>F.A.I. ROUTE 70 PAVEMENT MARKING PLANS</b>			
SCALE: 1' = 50'	SHEET NO.	OF SHEETS	STA. 1360+00 TO STA. 1345+00

F.A.I. RTE. 70	SECTION .	COUNTY MADISON	TOTAL SHEETS 150	SHEET NO. 91
FED. ROAD DIST. NO.		ILLINOIS FED. AID PROJECT CONTRACT NO. 76A73		

• 60-(7,8,9,10)RS, 60-(8,9,10)BR

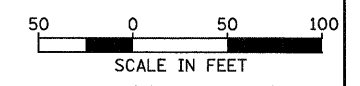
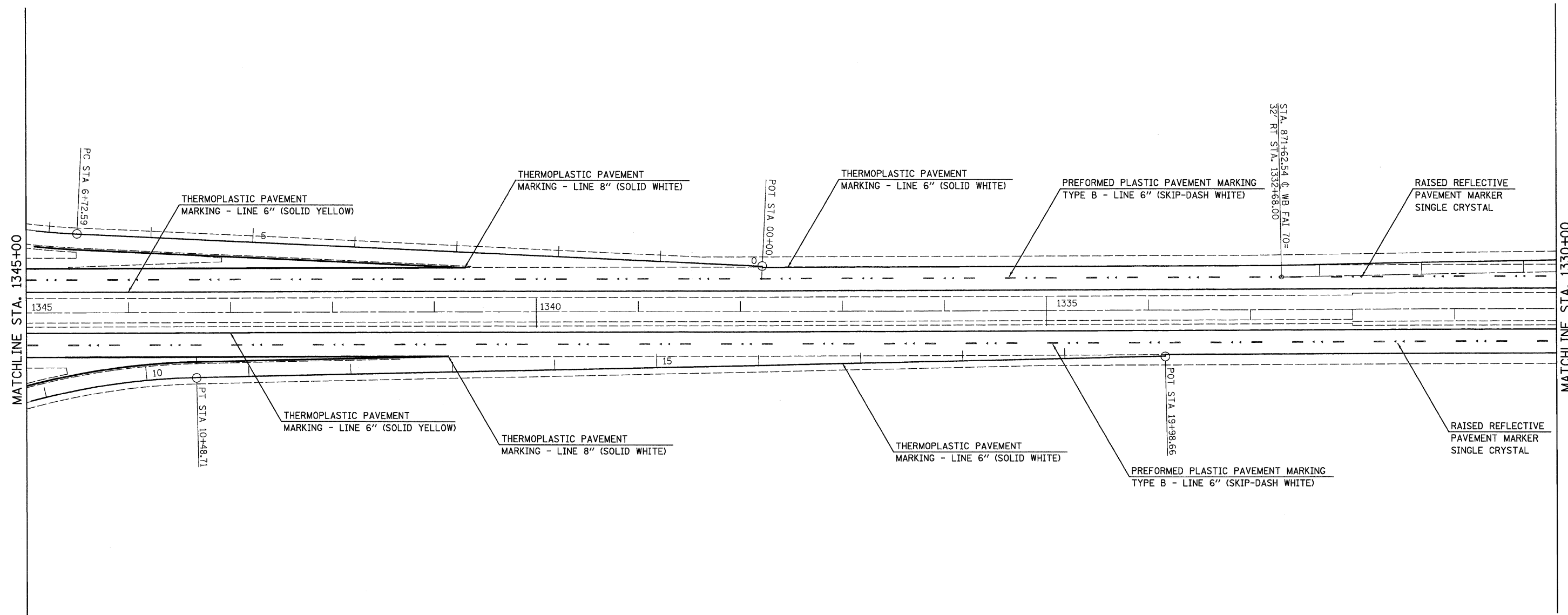

FILE NAME = ...\\0876A73-sht-pmk23.dgn 	USER NAME = SJS DESIGNED - DRAWN - CHECKED - DATE -	REVISED - REVISED - REVISED - REVISED -	<b>STATE OF ILLINOIS</b> <b>DEPARTMENT OF TRANSPORTATION</b>	<b>F.A.I. ROUTE 70</b> <b>PAVEMENT MARKING PLANS</b>		F.A.I. RTE. 70	SECTION *	COUNTY MADISON	TOTAL SHEETS 150	SHEET NO. 92
	PLOT SCALE = 50.0000' / IN. PLOT DATE = 06/12/2009 09:31:54	SCALE: 1' = 50' SHEET NO. OF SHEETS STA. 1345+00 TO STA. 1330+00		CONTRACT NO. 76A73 FED. ROAD DIST. NO. ILLINOIS FED. AID PROJECT						

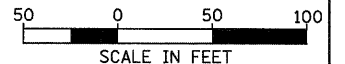
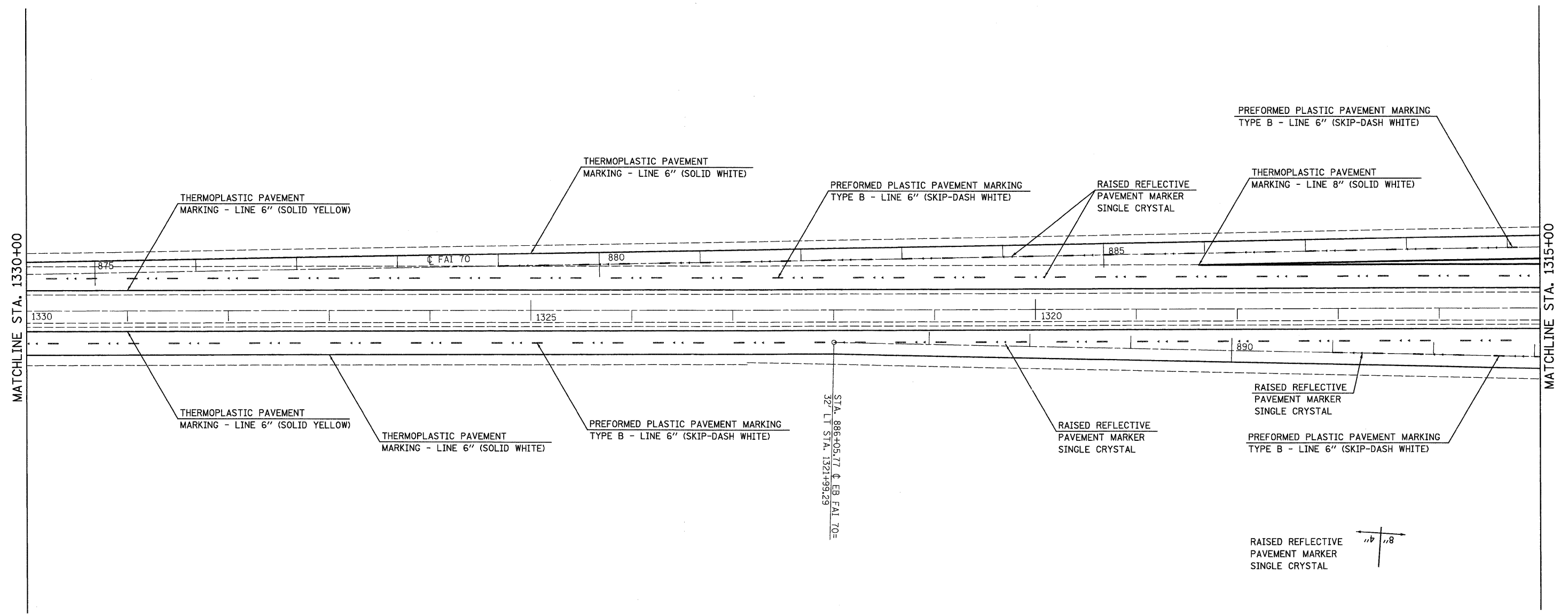

SCALE IN FEET  
• 60-(7,8,9,10)RS, 60-(8,9,10)BR

FILE NAME = ... \D876A73-eh-pmk24.dgn	USER NAME = SJS	DESIGNED -	REVISED -
Johnson, Depp & Quisenberry CONSULTING ENGINEERS Springfield, Illinois	PLOT SCALE = 50.0000' / IN.	DRAWN -	REVISED -
	PLOT DATE = 06/12/2009 09:32:06	CHECKED -	REVISED -
		DATE -	REVISED -

**STATE OF ILLINOIS  
DEPARTMENT OF TRANSPORTATION**

<b>F.A.I. ROUTE 70 PAVEMENT MARKING PLANS</b>			
SCALE: 1' = 50'	SHEET NO. OF SHEETS	STA. 1330+00 TO STA. 1315+00	

F.A.I. RTE. 70	SECTION •	COUNTY MADISON	TOTAL SHEETS 150	SHEET NO. 93
FED. ROAD DIST. NO.		ILLINOIS FED. AID PROJECT		
		CONTRACT NO. 76A73		

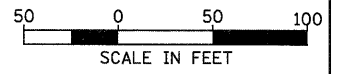
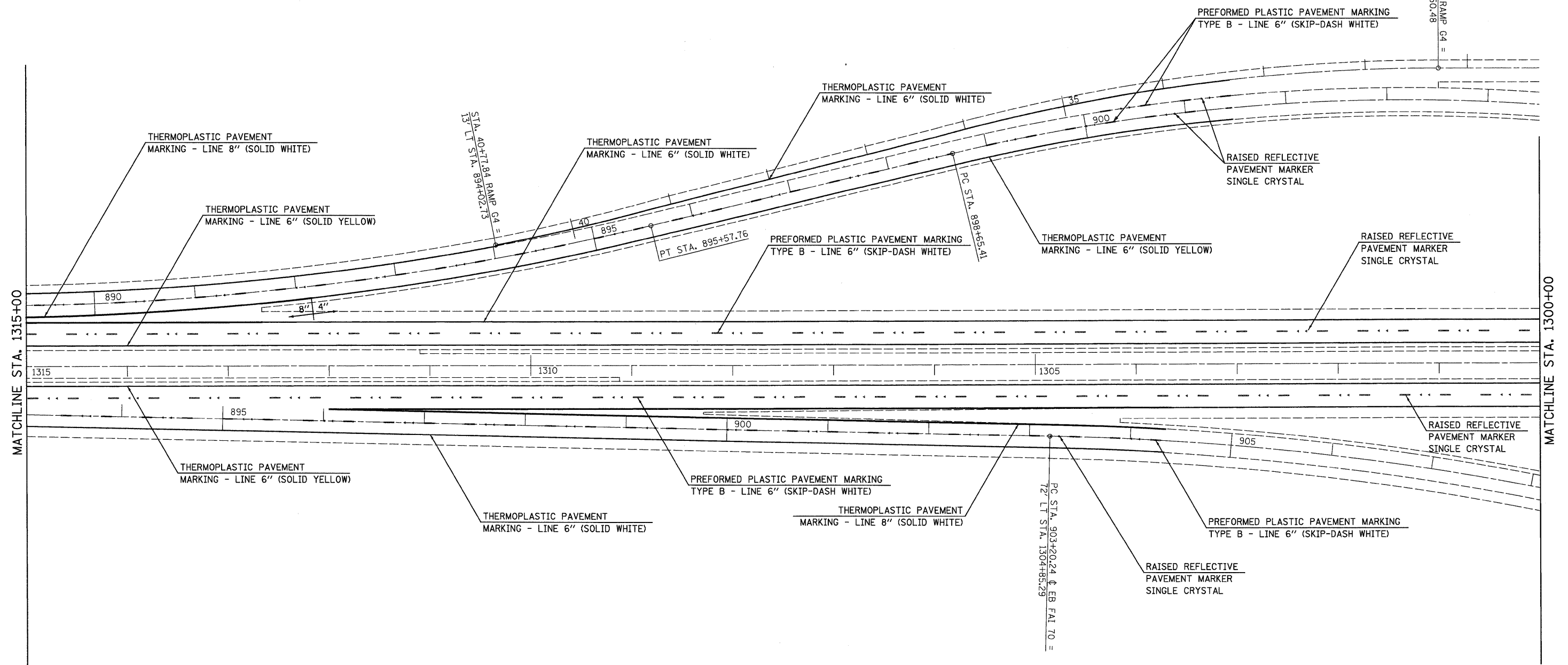

FILE NAME =	USER NAME = SJS	DESIGNED -	REVISED -
... \D876A73-eh-t-pmk25.dgn		DRAWN -	REVISED -
<b>Johnson, Depp &amp; Oulsenberry</b> CONSULTING ENGINEERS Springfield, Illinois	PLOT SCALE = 50.0000' / IN.	CHECKED -	REVISED -
	PLOT DATE = 06/12/2009 09:32:19	DATE -	REVISED -

**STATE OF ILLINOIS  
DEPARTMENT OF TRANSPORTATION**

<b>F.A.I. ROUTE 70 PAVEMENT MARKING PLANS</b>			
SCALE: 1' = 50'	SHEET NO.	OF SHEETS	STA. 1315+00 TO STA. 1300+00

F.A.I. RTE. 70	SECTION *	COUNTY MADISON	TOTAL SHEETS 150	SHEET NO. 94
FED. ROAD DIST. NO. ILLINOIS FED. AID PROJECT			CONTRACT NO. 76A73	

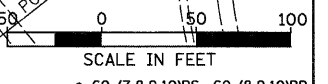
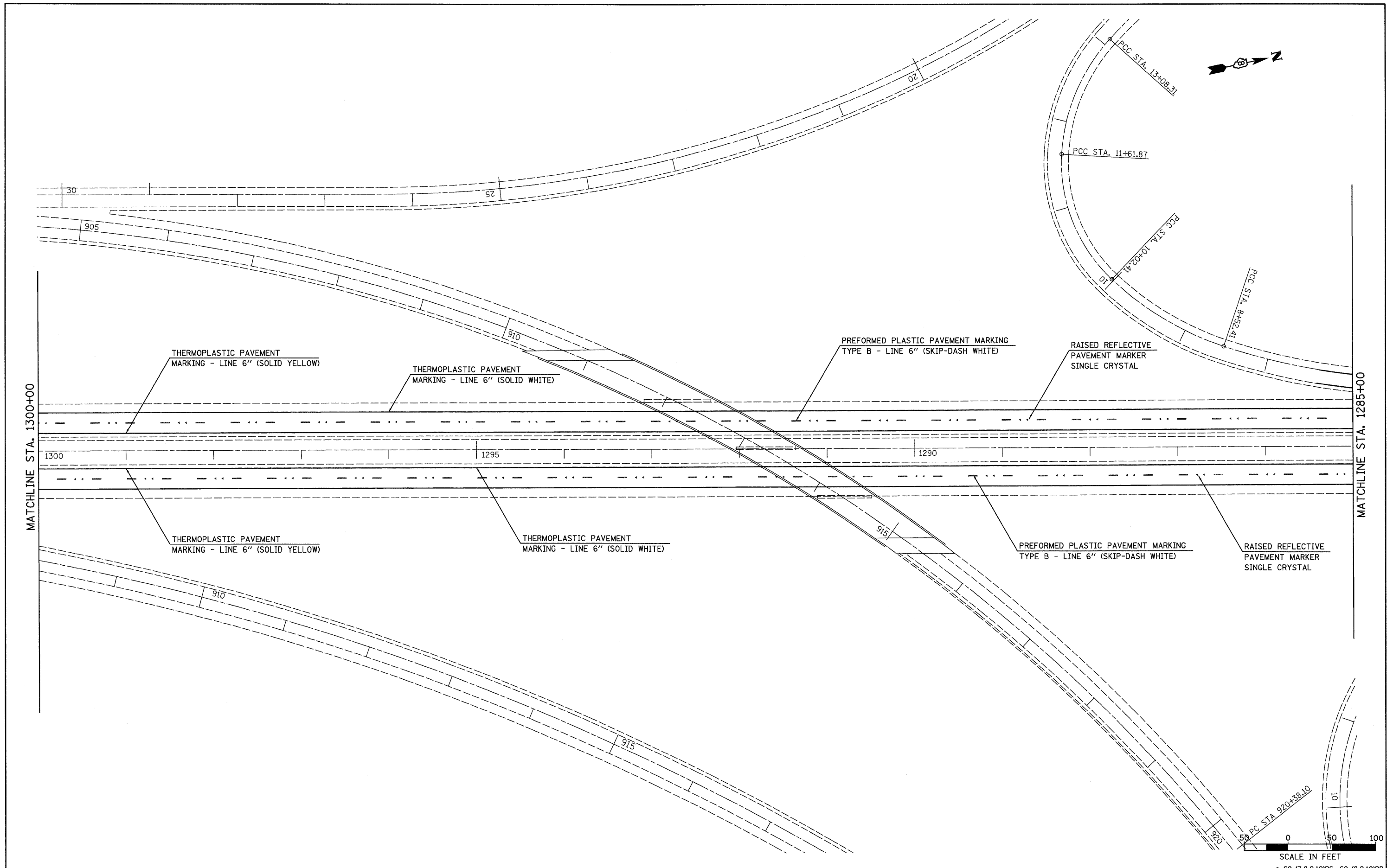

FILE NAME = ...N0876A73-aht-pmk26.dgn 	USER NAME = SJS	DESIGNED -	REVISED -	<b>STATE OF ILLINOIS</b> <b>DEPARTMENT OF TRANSPORTATION</b>	<b>F.A.I. ROUTE 70</b> <b>PAVEMENT MARKING PLANS</b>		F.A.I. RTE. 70	SECTION .	COUNTY MADISON	TOTAL SHEETS 150	SHEET NO. 95
	PLOT SCALE = 50.0000' / IN. PLOT DATE = 06/12/2009 09:32:32	DRAWN - CHECKED - DATE -	REVISED - REVISED - REVISED -		SCALE: 1' = 50' SHEET NO. OF SHEETS STA. 1300+00 TO STA. 1285+00	FED. ROAD DIST. NO. ILLINOIS FED. AID PROJECT	CONTRACT NO. 76A73				

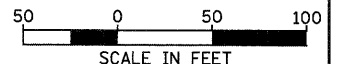
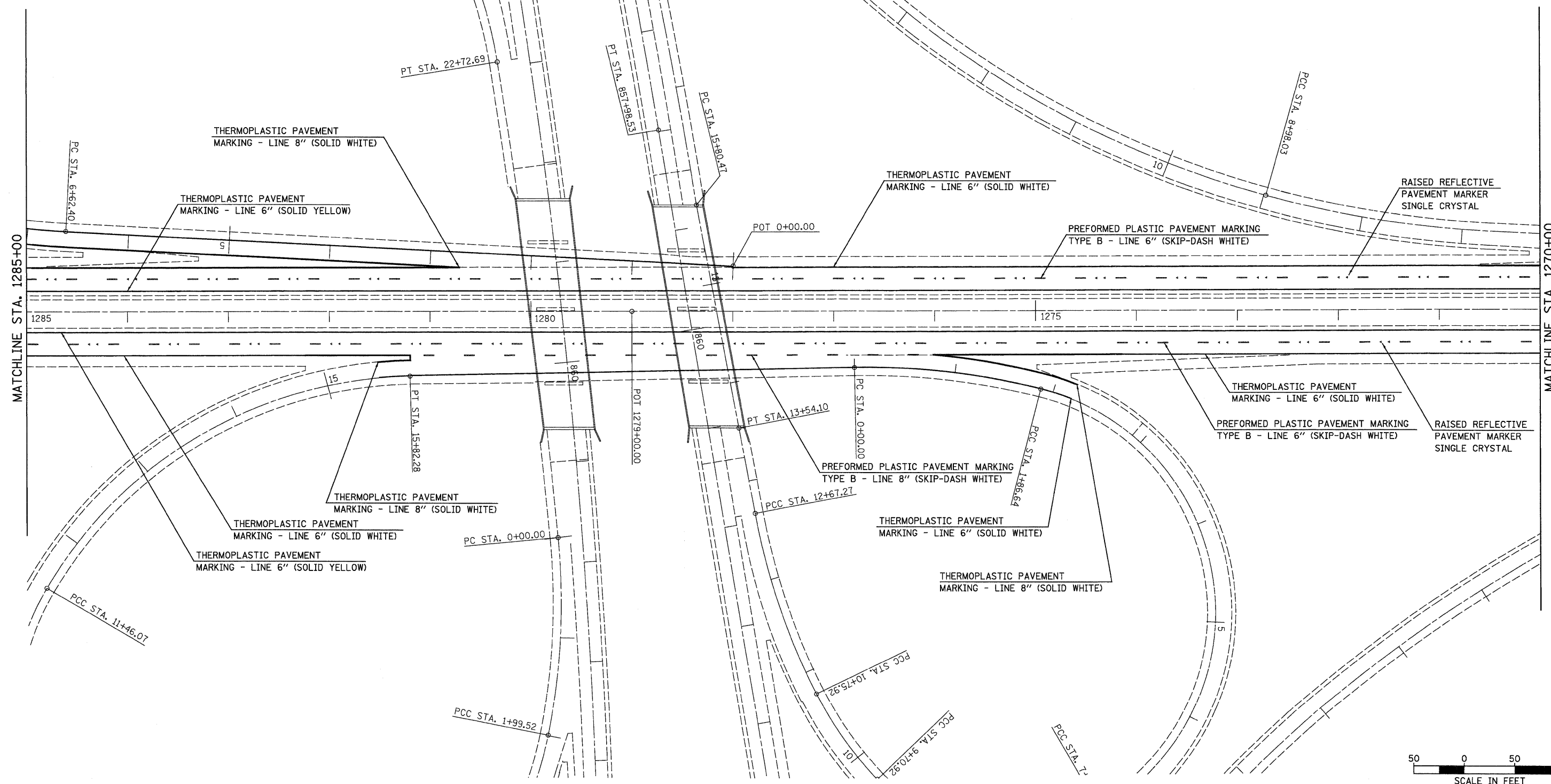

• 60-(7,8,9,10)RS, 60-(8,9,10)BR

FILE NAME = ...ND876A73-sht-pmk27.dgn  
**Johnson, Depp & Quisenberry**  
 CONSULTING ENGINEERS  
 Springfield, Illinois

USER NAME = SJS  
 PLOT SCALE = 50.0000' / IN.  
 PLOT DATE = 06/12/2009 09:32:46

DESIGNED -  
 DRAWN -  
 CHECKED -  
 DATE -

REVISED -  
 REVISED -  
 REVISED -  
 REVISED -

**STATE OF ILLINOIS  
 DEPARTMENT OF TRANSPORTATION**

**F.A.I. ROUTE 70  
 PAVEMENT MARKING PLANS**

SCALE: 1" = 50' SHEET NO. OF SHEETS STA. 1285+00 TO STA. 1270+00

F.A.I. RTE.	SECTION	COUNTY	TOTAL SHEETS	SHEET NO.
70		MADISON	150	96

CONTRACT NO. 76A73  
 FED. ROAD DIST. NO. ILLINOIS FED. AID PROJECT

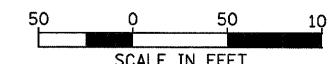
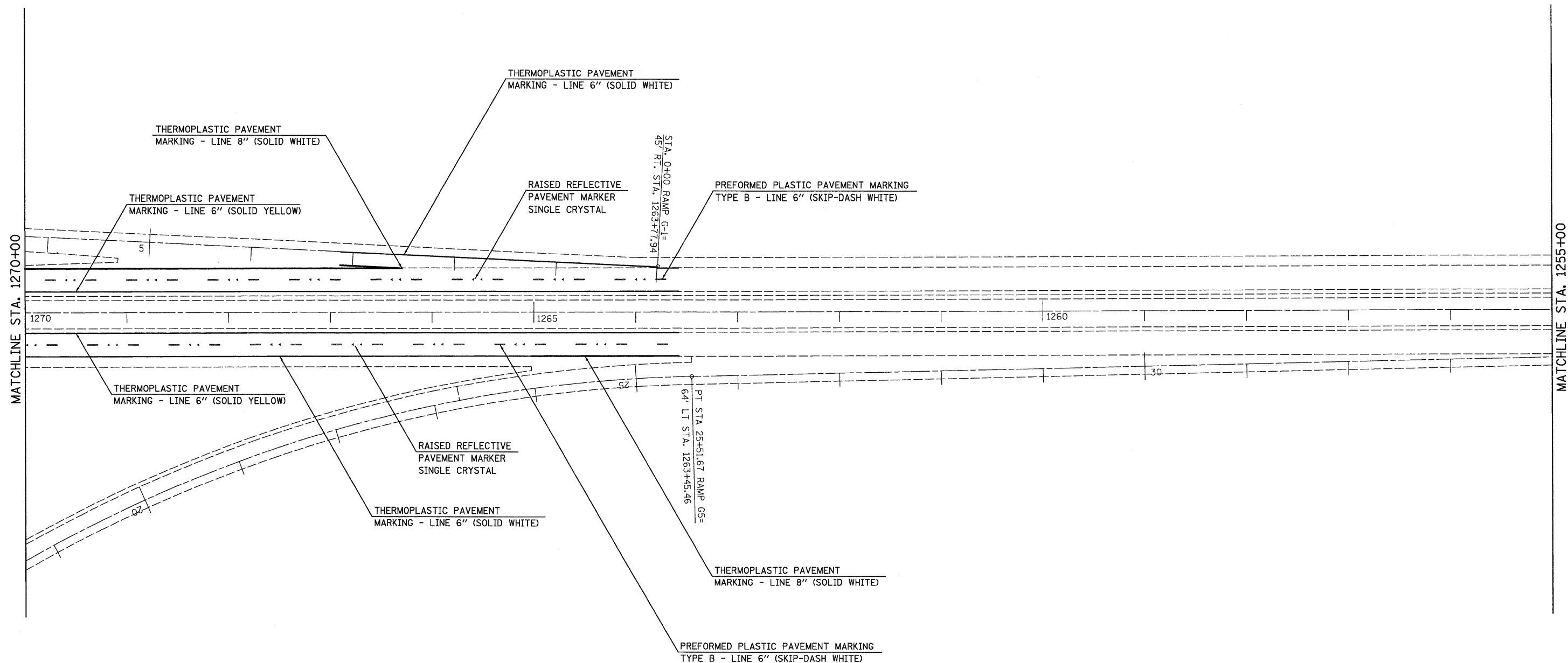

SCALE IN FEET  
• 60-(7,8,9,10)RS, 60-(8,9,10)BR

FILE NAME = ...N0876A73-sht-pmk2B.dgn 	USER NAME = SJS	DESIGNED -	REVISED -	<b>STATE OF ILLINOIS</b> <b>DEPARTMENT OF TRANSPORTATION</b>	<b>F.A.I. ROUTE 70</b> <b>PAVEMENT MARKING PLANS</b>		F.A.I. SECTION	COUNTY	TOTAL SHEETS	SHEET NO.
	PLOT SCALE = 50.0000' / IN.	CHECKED -	REVISED -		SCALE: 1' = 50'	SHEET NO. OF SHEETS	STA. 1270+00 TO STA. 1255+00	70	MADISON	150
PLOT DATE = 06/12/2009 09:32:59	DATE -	REVISED -	REVISED -			CONTRACT NO. 76A73		FED. ROAD DIST. NO. ILLINOIS FED. AID PROJECT		

STATE OF ILLINOIS  
DEPARTMENT OF TRANSPORTATION

Sheet No.	Description
1	Gen. Plan, Gen. Notes & Total Bill of Mat'l
2-3	Bearing Details

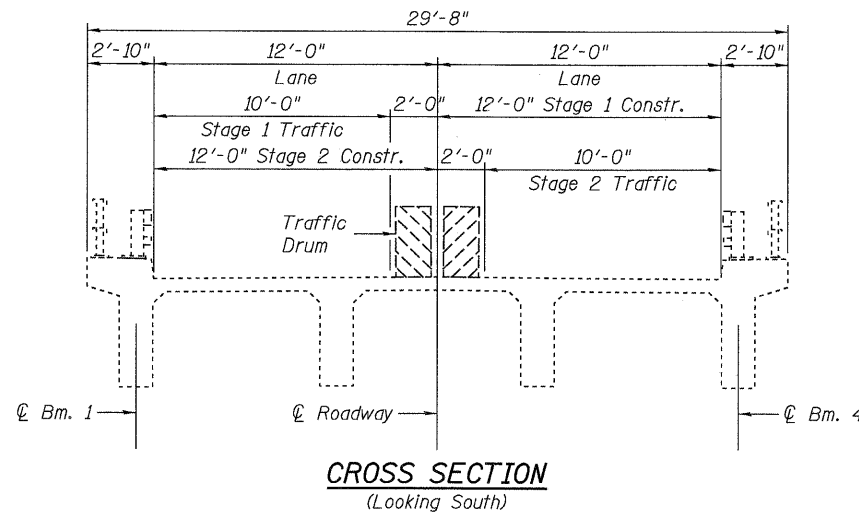
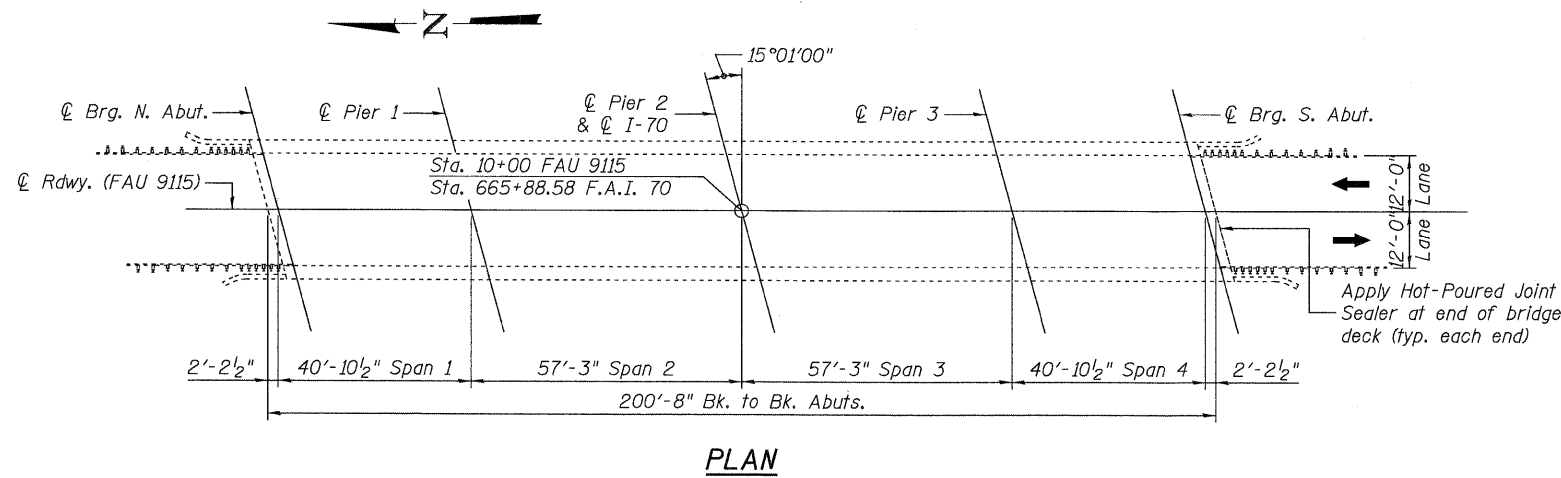
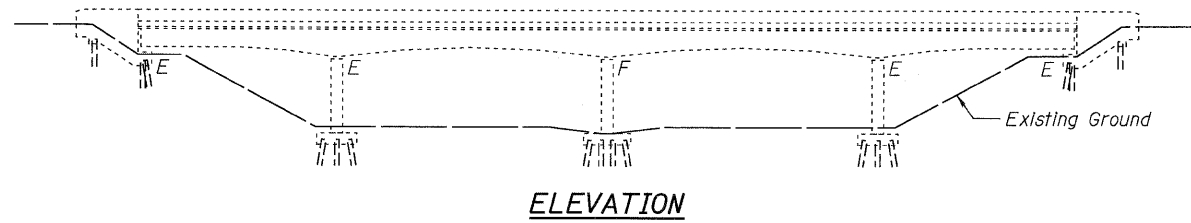

**GENERAL NOTES**

Concrete Sealer shall be applied to the surfaces of the bridge deck and parapets, including wings. See Special Provision for "BRIDGE DECK CONCRETE SEALER".

All structural steel shall be AASHTO M 270 Grade 36, unless noted otherwise.

The Organic Zinc Rich Primer / Epoxy / Urethane Paint System shall be used for painting of new structural steel except where otherwise noted. The entire system shall be shop applied, with the exception that masked off connection surfaces, field installed fasteners and damaged areas shall be touched up in the field. The color of the final finish coat for all steel surfaces shall be Gray, Munsell No. 5B 7/1. See Special Provision for "Cleaning and Painting New Metal Structures".

Existing structural steel that will be in contact with new structural steel shall be cleaned and painted prior to erection as required by the Special Provision "Cleaning and Painting Contact Surface Areas of Existing Steel Structures".

The existing structural steel coating contains lead. The Contractor shall take appropriate precautions to deal with the presence of lead on this project.

Plan dimensions and details relative to existing plans are subject to routine variations. The Contractor shall field verify existing dimensions and details affecting new construction and make necessary approved adjustments prior to construction or ordering of materials. Such variations shall not be cause for additional compensation for a change in scope of the work, however, the Contractor will be paid for the quantity actually furnished based upon the unit price bid for the work.

**TOTAL BILL OF MATERIAL**

ITEM	UNIT	SUPER	SUB	TOTAL
Joint Or Crack Filling	Pound	--	36	36
Furnishing And Erecting Structural Steel	Pound	--	3260	3260
Jack And Remove Existing Bearings	Each	--	16	16
Elastomeric Bearing Assembly, Type I	Each	--	16	16
Anchor Bolts, 1"	Each	--	40	40
Concrete Sealer	Sq Ft	6448	--	6448
Bridge Washing No. 1	Each	1	--	1

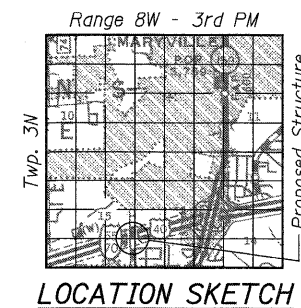

**GENERAL PLAN & ELEVATION  
PLEASANT RIDGE ROAD (FAU 9115) OVER  
F.A.I. ROUTE 70  
STRUCTURE NO. 060-0172**

SHEET 1 OF 3	F.A.I. RTE.	SECTION	COUNTY	TOTAL SHEETS	SHEET NO.
	70	60-(8,9,10)BR	MADISON	150	98
		STA. 665+88.58	CONTRACT NO. 76A73		
FED. ROAD DIST. NO.		ILLINOIS FED. AID PROJECT			

**JD** Johnson, Depp & Quisenberry  
CONSULTING ENGINEERS  
Springfield, Illinois



Signed: *David Depp*  
Date: *6-4-2009*  
Lic. Expires: 11-30-2010

DESIGNED: JDQ	DRAWN: PTR
CHECKED: DCD	CHECKED: DCD



STATE OF ILLINOIS  
DEPARTMENT OF TRANSPORTATION

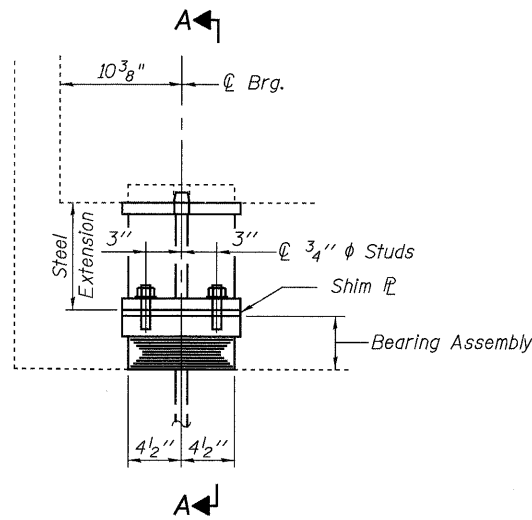

ELEVATION

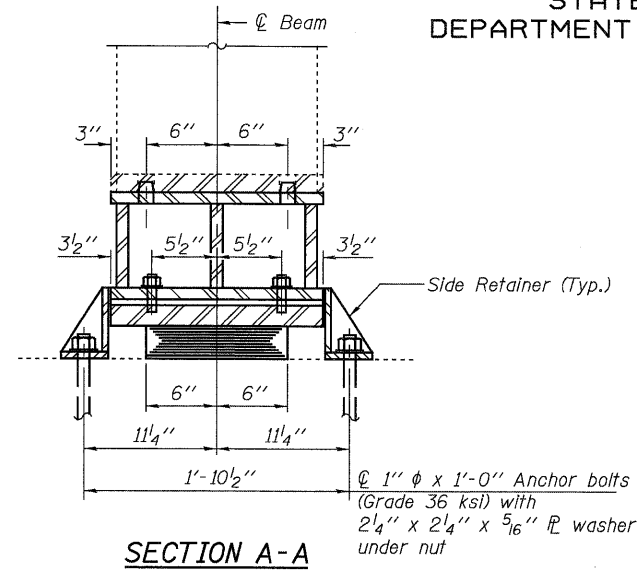

SECTION A-A

TYPE I ELASTOMERIC EXP. BRG. - ABUTMENTS

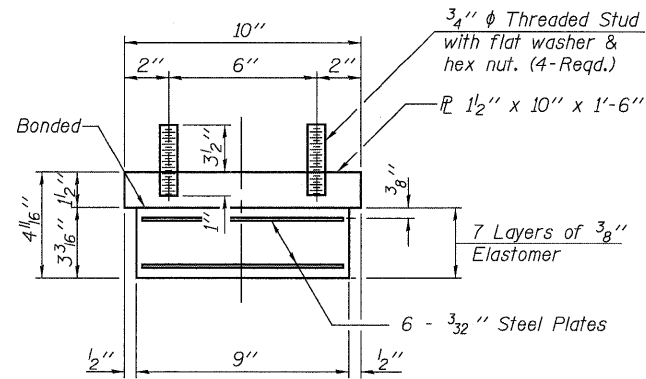

BEARING ASSEMBLY

Note:  
Shim plates shall not be placed under Bearing Assembly.

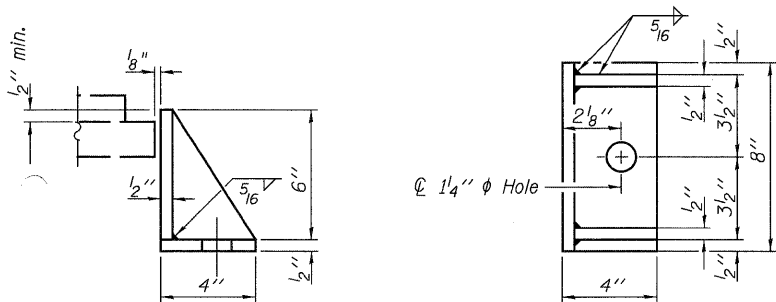

SIDE RETAINER

Equivalent rolled angle with stiffeners will be allowed in lieu of welded plates.

Notes:  
Anchor bolts shall be ASTM F1554 all-thread (or an Engineer-approved alternate material) of the grade(s) and diameter(s) specified. ASTM A307 Grade C anchor bolts may be used in lieu of ASTM F1554 Grade 36 (Fy=36ksi). The corresponding specified grade of AASHTO M314 anchor bolts may be used in lieu of ASTM F1554.  
Anchor bolts for side retainers shall be installed in holes drilled after members are in place.  
Drilled and set anchor bolts shall be installed according to Article 521.06 of the Standard Specifications.  
Side retainers shall be included in the cost of Elastomeric Bearing Assembly, Type I.

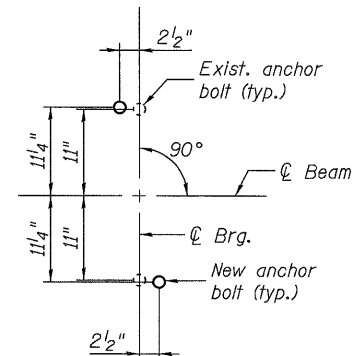

ANCHOR BOLT LAYOUT

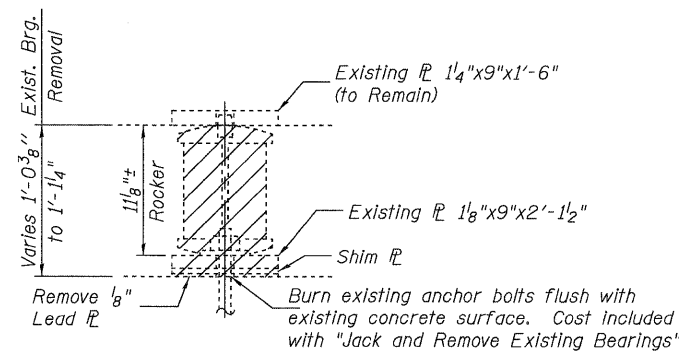

EXISTING BEARING REMOVAL DETAIL - ABUTS.

SHIM THICKNESS TABLE

Location	Beam 1	Beam 2	Beam 3	Beam 4
N. Abut.	-	1/4"	3/4"	-
S. Abut.	-	7/8"	1/2"	-

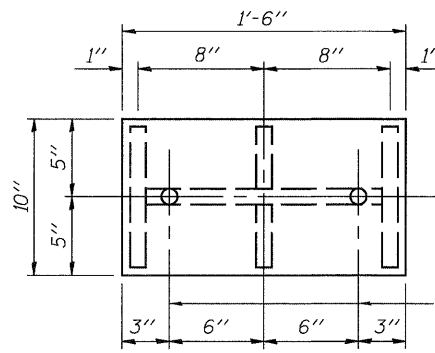

PLAN STEEL EXTENSION - TOP PL

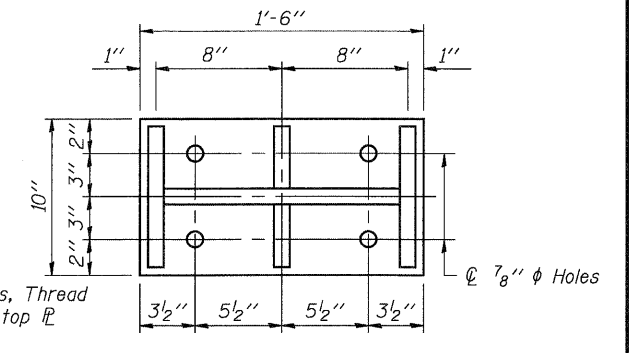

PLAN STEEL EXTENSION - BOTTOM PL

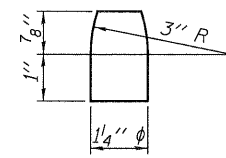

PINTLE

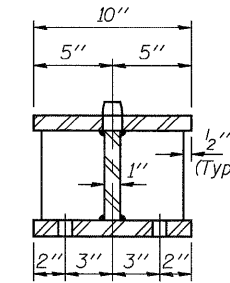

SECTION B-B

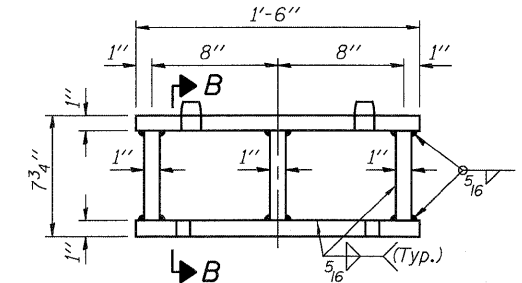

ELEVATION STEEL EXTENSION

Notes:  
Existing bearings at the Abutments and Piers 1 & 3 shall be removed and replaced according to the plans.

Jacking shall be according to the Special Provision for "JACK AND REMOVE EXISTING BEARINGS".

Prior to ordering any material, the Contractor shall verify in the field all bearing height and shim thickness dimensions.

Two 1/8 in. adjusting shims shall be provided for each bearing in addition to all other plates or shims and placed as shown on bearing details.

The structural steel plates of the bearing assembly shall conform to the requirements of AASHTO M 270 Grade 36.

New steel extensions, pintles, shim plates and connection bolts are included with Furnishing and Erecting Structural Steel.

BILL OF MATERIAL

Item	Unit	Total
Jack and Remove Existing Bearings	Each	8
Elastomeric Bearing Assembly Type I	Each	8
Furnishing and Erecting Structural Steel	Pound	1480
Anchor Bolts, 1"	Each	16

INTERIOR GIRDER REACTION TABLE	
	Abuts.
R (DL)	(K) 17.5
R (LL)	(K) 39.4
R (Imp)	(K) 11.8
R (Total)	(K) 68.7
Minimum Jack Capacity (Tons)	35

BEARINGS - ABUTMENTS  
PLEASANT RIDGE ROAD (FAU 9115) OVER  
F.A.I. ROUTE 70  
STRUCTURE NO. 060-0172

SHEET 2 OF 3	F.A.I. RTE.	SECTION	COUNTY	TOTAL SHEETS	SHEET NO.
	70	60-(8,9,10)BR	MADISON	150	99
STA. 665+88.58		CONTRACT NO. 76A73			
FED. ROAD DIST. NO. ILLINOIS FED. AID PROJECT					

**JD Johnson, Depp & Quisenberry**  
CONSULTING ENGINEERS  
Springfield, Illinois

DESIGNED: JDQ DRAWN: PTR  
CHECKED: DCD CHECKED: DCD

I-2E-1 10-1-08 (Modified)

STATE OF ILLINOIS  
DEPARTMENT OF TRANSPORTATION

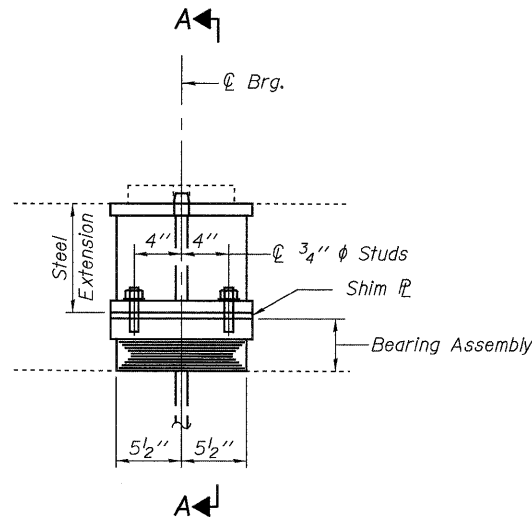

ELEVATION

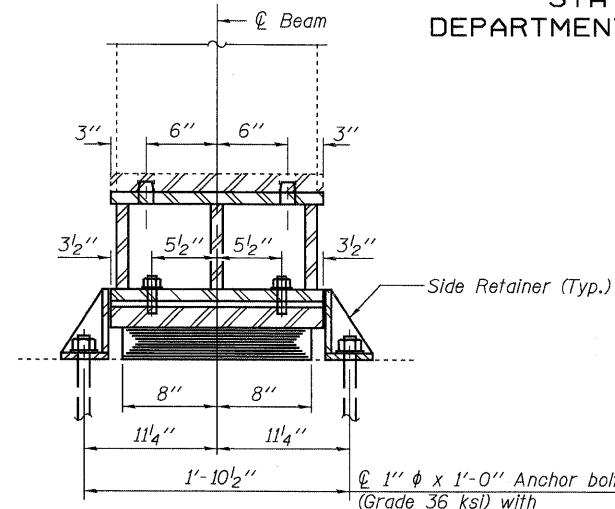

SECTION A-A

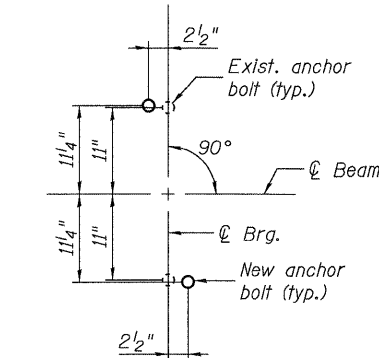

ANCHOR BOLT LAYOUT

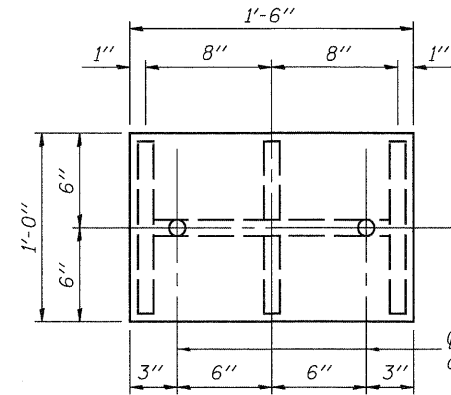

PLAN STEEL EXTENSION - TOP

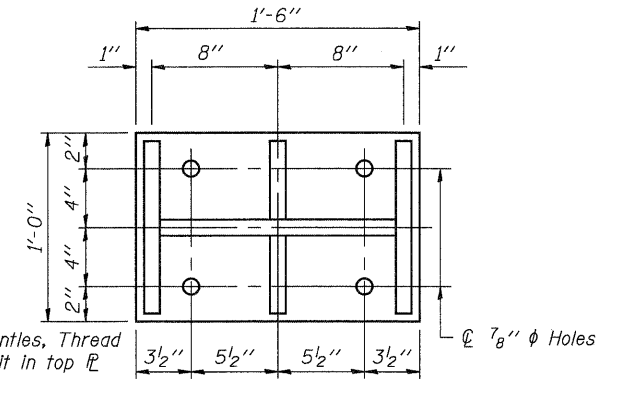

PLAN STEEL EXTENSION - BOTTOM

TYPE I ELASTOMERIC EXP. BRG. - PIERS 1 & 3

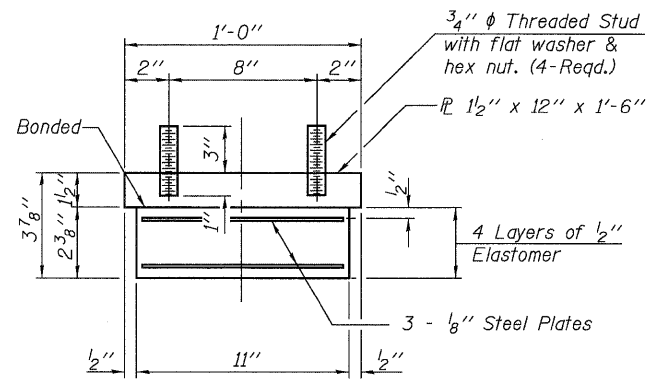

BEARING ASSEMBLY

Notes:  
Anchor bolts shall be ASTM F1554 all-thread (or an Engineer-approved alternate material) of the grade(s) and diameter(s) specified. ASTM A307 Grade C anchor bolts may be used in lieu of ASTM F1554 Grade 36 (Fy=36ksi). The corresponding specified grade of AASHTO M314 anchor bolts may be used in lieu of ASTM F1554.  
Anchor bolts at fixed bearings shall be installed in holes drilled after the supported member is in place.  
Anchor bolts for side retainers shall be installed in holes drilled after members are in place.  
Drilled and set anchor bolts shall be installed according to Article 521.06 of the Standard Specifications.  
Side retainers shall be included in the cost of Elastomeric Bearing Assembly, Type I.

Note:  
Shim plates shall not be placed under Bearing Assembly.

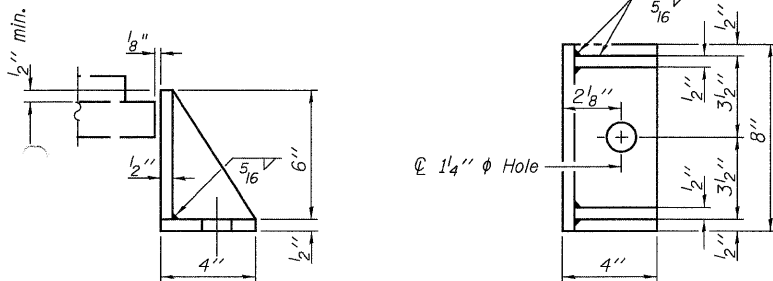

SIDE RETAINER

Equivalent rolled angle with stiffeners will be allowed in lieu of welded plates.

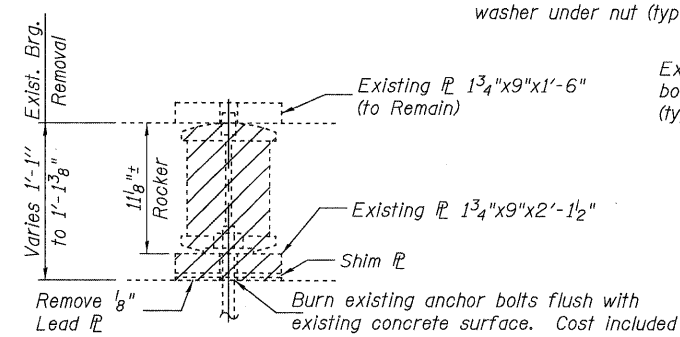

EXISTING BEARING REMOVAL DETAIL - PIERS 1 & 3

SHIM THICKNESS TABLE

Location	Beam 1	Beam 2	Beam 3	Beam 4
Pier 1	-	-	3/8"	-
Pier 2	-	-	-	1/4"
Pier 3	-	1/4"	-	-

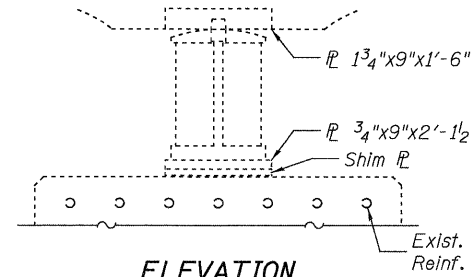

ELEVATION

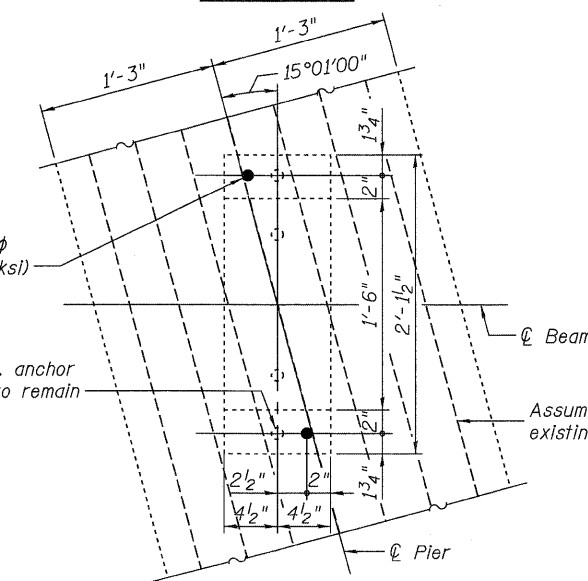

PLAN

FIXED BEARING RETROFIT - PIER 2

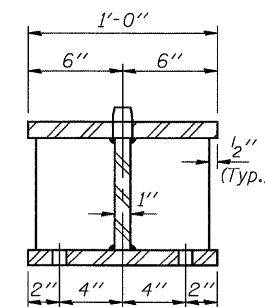

SECTION B-B

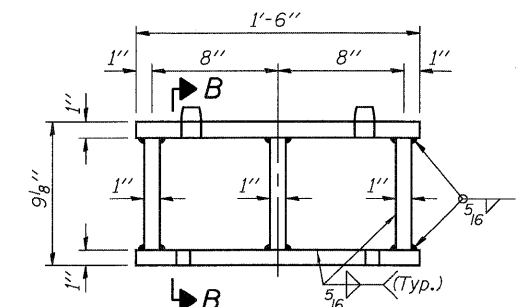

ELEVATION STEEL EXTENSION

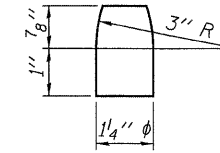

PINTLE

NOTES:  
See Sheet 2 of 3 for additional Notes.

BILL OF MATERIAL

Item	Unit	Total
Jack and Remove Existing Bearings	Each	8
Elastomeric Bearing Assembly Type I	Each	8
Furnishing and Erecting Structural Steel	Pound	1780
Anchor Bolts, 1"	Each	24

BEARINGS - PIERS

PLEASANT RIDGE ROAD (FAU 9115) OVER  
F.A.I. ROUTE 70  
STRUCTURE NO. 060-0172

INTERIOR GIRDER REACTION TABLE		
		Piers 1 & 3
R (DL)	(K)	83.4
R (LL)	(K)	53.9
R (Imp)	(K)	15.5
R (Total)	(K)	152.8
Minimum Jack Capacity	(Tons)	80

SHEET 3 OF 3	F.A.I. RTE.	SECTION	COUNTY	TOTAL SHEETS	SHEET NO.
	70	60-(8,9,10)BR	MADISON	150	100
	STA. 665+88.58	CONTRACT NO. 76A73			
	FED. ROAD DIST. NO.	ILLINOIS FED. AID PROJECT			

**JD** Johnson, Depp & Quisenberry  
CONSULTING ENGINEERS  
Springfield, Illinois

DESIGNED: JDQ DRAWN: PTR  
CHECKED: DCD CHECKED: DCD

I-2E-1 10-1-08 (Modified)

FILE: m:\projects\10166 il-cbvv\11-70 resurfacing\1-en0600172-pleasantridge\0600172-76A73-003-Bearings.dgn  
USER: SJS  
DATE: 06/11/2009 17:55:58