

SECTION	COUNTY	TOTAL SHEETS	SHEET NO.
08-00037-02-BR	PEORIA	21	2
ILLINOIS CONTRACT # 89372			

GENERAL NOTES

ALL CONSTRUCTION WILL BE IN ACCORDANCE WITH THE APPLICABLE SECTIONS OF THE ILLINOIS DEPARTMENT OF TRANSPORTATION'S STANDARD SPECIFICATIONS FOR ROAD AND BRIDGE CONSTRUCTION, JANUARY 1, 2007 EDITION AND ALL APPLICABLE SUPPLEMENTAL SPECIFICATIONS (HEREAFTER REFERRED TO JOINTLY AS IDOT STANDARD SPECIFICATIONS).

CONTRACTOR TO FIELD VERIFY ALL DIMENSIONS PRIOR TO ORDERING MATERIALS.

ANY REFERENCE TO A STANDARD IN THESE PLANS SHALL BE INTERPRETED TO MEAN THE EDITION AS INDICATED BY THE SUB-NUMBER LISTED IN THE INDEX OF SHEETS OR THE COPY OF THE STANDARD INCLUDED IN THESE PLANS.

WHERE SECTION OR SUBSECTION MONUMENTS ARE ENCOUNTERED, THE ENGINEER SHALL BE NOTIFIED BEFORE SUCH MONUMENTS ARE REMOVED. THE CONTRACTOR SHALL PROTECT AND CAREFULLY PRESERVE ALL MONUMENTS UNTIL AN AUTHORIZED SURVEYOR OR AGENT HAS WITNESSED OR OTHERWISE REFERENCED THEIR LOCATION. THE CONTRACTOR WILL BE RESPONSIBLE FOR HAVING AN AUTHORIZED SURVEYOR REESTABLISH ANY SECTION OR SUBSECTION MONUMENTS DESTROYED BY HIS OPERATIONS.

UNLESS OTHERWISE DIRECTED BY THE ENGINEER, RIGHT OF WAY MARKERS SHALL BE INSTALLED AS A FIRST ITEM OF CONSTRUCTION ON THIS CONTRACT.

THE FOLLOWING RATES OF APPLICATION HAVE BEEN ASSUMED IN CALCULATIONS OF PLAN QUANTITIES:

GRANULAR MATERIALS	2.05 TONS/CU YD
BITUMINOUS MATERIALS PRIME COAT	0.075 GAL/SQ YD
AGGREGATE PRIME COAT	0.002 TONS/SQ YD
BITUMINOUS CONCRETE SURFACE COARSE	112 LBS/SQ YD INCH
NITROGEN FERTILIZER NUTRIENT	90 LBS/ACRE
PHOSPHOROUS FERTILIZER NUTRIENT	90 LBS/ACRE
POTASSIUM FERTILIZER NUTRIENT	90 LBS/ACRE
SHORT TERM PAVEMENT MARKING	10 FT/100 FT OF APP
MIXTURE FOR CRACKS, JOINTS & FLANGWAYS	0.0003 TONS/SQ YD
MULCH, METHOD 2	2 TONS/ACRE
EMULSIFIED ASPHALT	100 GAL/TON OF MULCH
SUPPLEMENTAL WATERING	3 GAL/SY/APP

THE CONTRACTOR SHALL BE RESPONSIBLE FOR PROTECTING ALL UTILITIES FROM CONSTRUCTION OPERATIONS AS OUTLINED IN ARTICLE 107.31 OF IDOT STANDARD SPECIFICATIONS. ANY UTILITIES THAT ARE DISTURBED DURING CONSTRUCTION WILL BE REPAIRED AND/OR RELOCATED AT NO COST TO THE OWNER. THE J.U.L.I.E. NUMBER IS 800-892-0123. A MINIMUM OF FORTY-EIGHT (48) HOURS NOTICE IS REQUIRED.

MEMBERS OF J.U.L.I.E. KNOWN TO BE WITHIN THE LIMITS OF IMPROVEMENT ARE:

- GAS: AMEREN CILCO
- ELECTRIC: AMEREN CILCO
- COMMUNICATIONS: AT&T, MCLEOD USA
- CABLE: TEL-STAR CABLEVISION
- WATER: PLEASANT VALLEY PUBLIC WATER, T-L RURAL WATER DISTRICT

ALL LOCATIONS OF UTILITIES ARE APPROXIMATE. CONTRACTOR TO VERIFY LOCATIONS WITH UTILITIES WITH THE RESPECTIVE UTILITY OWNERS PRIOR TO CONSTRUCTION. CONTRACTOR SHALL PERFORM EXPLORATORY EXCAVATION TO VERIFY HORIZONTAL AND VERTICAL LOCATIONS OF EXISTING UTILITIES. ANY AND ALL UTILITY COORDINATION AND RELATED EXPLORATORY WORK SHALL BE CONSIDERED INCLUDED IN THE CONTRACT.

ABANDONED UNDERGROUND UTILITIES THAT CONFLICT WITH CONSTRUCTION SHALL BE DISPOSED OF OUTSIDE THE LIMITS OF THE RIGHT OF WAY ACCORDING TO ARTICLE 202.03 OF THE STANDARD SPECIFICATIONS AND AS DIRECTED BY THE ENGINEER. THIS WORK WILL NOT BE PAID FOR SEPARATELY, BUT SHALL BE CONSIDERED INCLUDED IN THE CONTRACT AND NO ADDITIONAL COMPENSATION WILL BE ALLOWED.

THE EXISTING ROAD SIGNS THAT INTERFERE WITH CONSTRUCTION WILL BE RELOCATED AS DIRECTED BY THE ENGINEER. AFTER THE CONSTRUCTION IS COMPLETED, THE CONTRACTOR WILL REPLACE THE SIGNS AS DIRECTED BY THE ENGINEER. THIS WORK WILL NOT BE PAID SEPARATELY BUT SHALL BE CONSIDERED INCLUDED IN THE CONTRACT AND NO COMPENSATION WILL BE ALLOWED.

THE PAVEMENT AND STRUCTURES ON OR ADJACENT TO THE WORK SHALL BE PROTECTED FROM DAMAGE BY EQUIPMENT. ANY DAMAGE SHALL BE REPAIRED BY THE CONTRACTOR AT HIS/HER OWN EXPENSE. CONTRACTOR SHALL REMOVE AND REPLACE DRIVEWAYS PARTIALLY DAMAGED DURING CONSTRUCTION AS DIRECTED BY THE ENGINEER.

EXCEPT AS NOTED IN THE PLANS, PAVEMENT GRADES SHOWN ARE AT THE TOP OF PAVEMENT SURFACES.

BEFORE ORDERING PIPE CULVERTS OR PIPE DRAINS, THE CONTRACTOR SHALL CONSULT THE ENGINEER FOR EXACT LENGTHS.

UNLESS OTHERWISE INDICATED, EXISTING SURFACE TOPOGRAPHY AND DRAINAGE SHALL NOT BE ALTERED BY CONSTRUCTION. CONTRACTOR SHALL RESTORE TO ORIGINAL CONDITION AND DRAINAGE FEATURE DISTURBED BY CONSTRUCTION AT NO ADDITIONAL COST TO THE CONTRACT.

ALL DRAINAGE STRUCTURES AND SYSTEMS INSTALLED DURING CONSTRUCTION SHALL BE PROTECTED BY STANDARD EROSION CONTROL ITEMS AS DETAILED ON THE EROSION CONTROL SHEETS.

ONLY THOSE TREES DESIGNATED BY THE ENGINEER OR LISTED IN THE TREE REMOVAL SCHEDULE SHALL BE REMOVED. THE CONTRACTOR WILL PROTECT ALL REMAINING TREES FROM DAMAGE DUE TO HIS OPERATIONS.

ALL EROSION CONTROL MEASURES WILL BE IN ACCORDANCE WITH THE APPLICABLE SECTIONS OF THE IDOT STANDARD SPECIFICATIONS AND THE IEPA/USDA NRCS ILLINOIS URBAN MANUAL, 1995 (FROM THE ILLINOIS DEPARTMENT OF AG. SOIL CONSERVATION SERVICE).

CONSTRUCTION OPERATIONS SHALL BE CONDUCTED IN SUCH A MANNER THAT EROSION AND WATER POLLUTION WILL BE MINIMIZED.

ALL EARTHWORK OPERATIONS SHALL BE CONDUCTED SO THAT POSITIVE DRAINAGE IS PROVIDED AT ALL TIMES. DITCHES AND WATERWAYS SHALL BE CONSTRUCTED AND MAINTAINED TO THE LINES, GRADES, AND CROSS SECTIONS SHOWN ON THE PLANS. THE CONTRACTOR SHALL ALSO EXCAVATE A DITCH AT THE TOW OF THE SLOPE OF FILLS AND AT THE TOE OF SLOPE OF CUTS AT LOCATIONS DESIGNATED BY THE OWNER OR HIS REPRESENTATIVE AT THE EARLIEST OPPORTUNITY DURING CONSTRUCTION TO CONTROL RUNOFF FROM THE EMBANKMENT OR CUT SECTION. EXCAVATED MATERIAL FROM DITCHES AT THE TOP OF SLOPE CUTS SHALL BE PLACED IN A WINDROW BETWEEN THE DITCH AND TOE OF SLOPE.

SEDIMENT TRAPS, SILT FENCES, AND OTHER EROSION CONTROL ITEMS WILL BE INSPECTED AFTER EACH RAIN AND REPAIRS MADE AS NEEDED. INSPECTION AND REPAIR WILL NOT BE PAID FOR SEPARATELY BUT WILL BE CONSIDERED INCLUDED IN THE EROSION CONTROL BEING INSPECTED AND REPAIRED.

SEEDING WILL NOT BE PERMITTED AT ANY TIME WHEN THE GROUND IS FROZEN, WET, OR IN AN UNTILLABLE CONDITION. AREAS TO BE SEEDDED SHALL BE DETERMINED BY THE ENGINEER.

PERMANENT SEEDING SHALL BE ESTABLISHED AT THE EARLIEST POSSIBLE TIME USING THE PREVIOUSLY MENTIONED APPLICATIONS RATES.

MULCH, METHOD 2 WILL BE APPLIED TO ALL SEEDDED AREAS IN ACCORDANCE WITH SECTION 251 OF THE STANDARD SPECIFICATIONS.

ENVIRONMENTAL REVIEWS

PRIOR TO THE USE OF ANY PROPOSED BORROW AREAS, USE AREAS (TEMPORARY ACCESS ROADS, DETOURS, RUN-AROUNDS, ETC.) AND/OR WASTE AREAS, THE CONTRACTOR SHALL FILE THE REQUIRED ENVIRONMENTAL RESOURCE REQUEST SURVEYS ACCORDING TO SECTION 107.22 OF THE STANDARD SPECIFICATIONS. THESE SURVEYS ARE REQUIRED IN ORDER FOR THE DEPARTMENT TO CONDUCT CULTURAL AND BIOLOGICAL RESOURCE SURVEYS FOR THE PROPOSED SITE.

PRIOR TO ANY WASTE MATERIALS BEING REMOVED FROM THE CONSTRUCTION SITE THE REQUIRED ENVIRONMENTAL RESOURCE SURVEYS WILL NEED TO BE OBTAINED AND FILED BY THE CONTRACTOR. EXCESS WASTE PRODUCTS REMOVED FROM THE CONSTRUCTION SITE SHALL BE DISPOSED OF AS REQUIRED IN SECTION 202.03 OF THE STANDARD SPECIFICATIONS.

ANY PROTRUDING METAL BARS SHALL BE REMOVED PRIOR TO THE DISPOSAL OF BROKEN CONCRETE AT APPROVED DISPOSAL SITES.

THE REQUIRED ENVIRONMENTAL RESOURCE DOCUMENTATION SHALL INCLUDE THE FOLLOWING:

- BDE FORM 2289 (ENVIRONMENTAL SURVEY REQUEST)
- A LOCATION MAP SHOWING THE SIZE LIMITS AND LOCATION OF THE USE AREA
- SIGNED PROPERTY OWNER AGREEMENT FORM - D4 P10100
- COLOR PHOTOGRAPHS DEPICTING THE USE AREA
- BORROW AREA ENTRY AGREEMENT FORM - D4 P10101

PLEASE NOTE THAT A MINIMUM OF TWO WEEKS SHALL BE ALLOWED FOR THE DISTRICT TO OBTAIN THE REQUIRED ENVIRONMENTAL CLEARANCES.

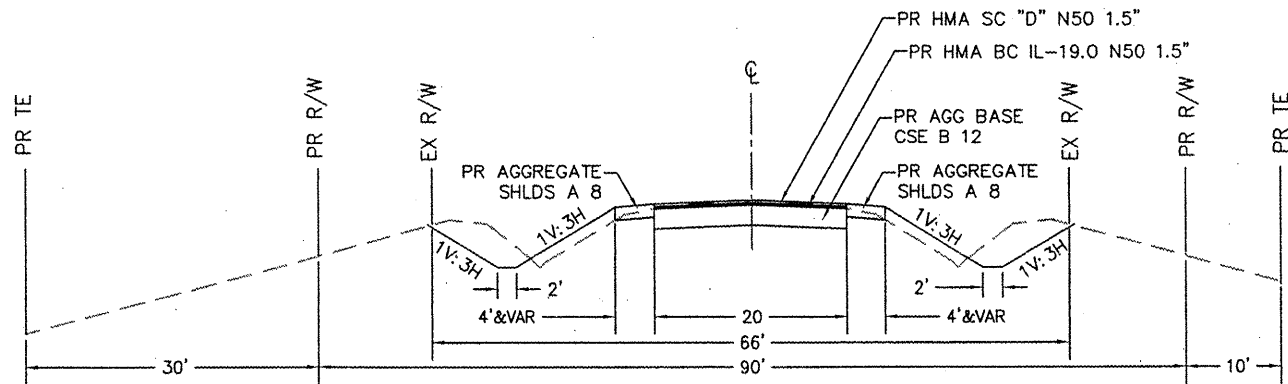

**PROPOSED TYPICAL SECTION
STA 0+00 TO 1+27 AND STA 2+08 TO 2+50**

HOT-MIX ASPHALT MIXTURE REQUIREMENTS		
MIXTURE USE(S)	SURFACE COURSE	BINDER COURSE
	1 1/2"	1 1/2"
AC/PG:	SBS OR SBR PG64-22	SBS OR SBR PG64-22
% RAP (MAX):	10%	10%
DESIGN AIR VOIDS:	4.0% @ N=50	4.0% @ N=50
MIXTURE COMPOSITION: (GRADATION MIXTURE)	IL 9.5 OR 12.5	IL 19.0
FRICITION AGGREGATE	MIXD	N.A.

LEGEND

- > GUY ANCHOR
- W WATER VALVE
- G GAS VALVE
- o EXISTING POWER POLE
- o EXISTING POWER POLE WITH TRANSFORMER
- o EXISTING POWER POLE WITH LIGHT
- o EXISTING SIGN
- o TELEPHONE PEDESTAL
- o FIRE HYDRANT
- o WATER VALVE
- o MANHOLE
- o ELECTRIC MANHOLE
- o CONIFEROUS TREE
- o DECIDUOUS TREE

- EX RIGHT OF WAY
- PROPOSED RIGHT OF WAY
- PROPERTY LINE
- EXISTING EASEMENT
- PROPOSED TEMPORARY EASEMENT
- PROPOSED DRAINAGE EASEMENT
- ☁ TREELINE
- (UE)--- UNDERGROUND ELECTRIC
- (OE)--- OVERHEAD ELECTRIC
- (CTV)--- CABLE TV
- (T)--- TELEPHONE
- (G)--- UNDERGROUND GAS
- (W)--- WATERMAIN
- EXISTING SHOULDER
- EXISTING EDGE OF PAVEMENT
- EXISTING DITCH FLOWLINE
- EXISTING SANITARY SEWER
- PROPOSED DITCH FLOWLINE
- PROPOSED DITCH FLOW DIRECTION
- PROPOSED EDGE OF PAVEMENT

REVISIONS			
NO.	DATE	DESCRIPTION	APPROVED

DESIGNED AJS
DRAWN AJS, JLA
CHECKED EEA
DATE 06/10/09



TYPICAL SECTIONS, GENERAL NOTES
PEORIA COUNTY HIGHWAY DEPT.
MCCULLOUGH ROAD BRIDGE #072-3063
6915 W. PLANK ROAD
PEORIA, ILLINOIS 61604