

HOT-MIX ASPHALT TRANSITION DETAIL
TO BE USED: MAIN STREET STA. 19+00
SHAMROCK AVENUE

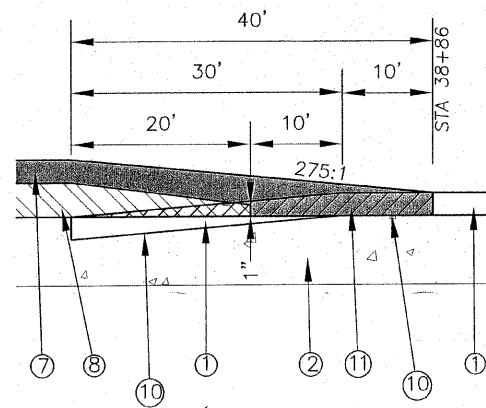

BUTT JOINT DETAIL
TO BE USED: MAIN STREET STA 38+86

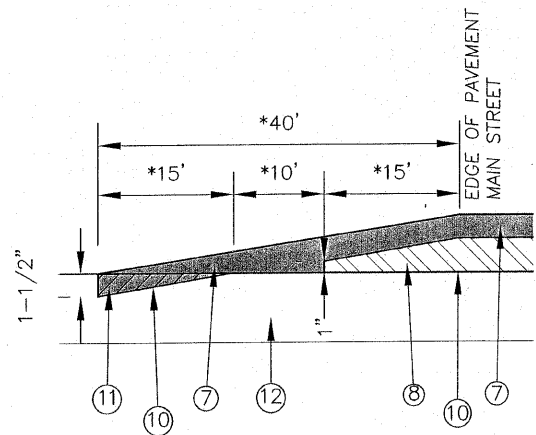

BUTT JOINT DETAIL
TO BE USED: BROADWAY AVENUE
MONROE AVENUE
BOWMAN AVENUE

* DISTANCE MEASURED ALONG C/L OF SIDE STREET

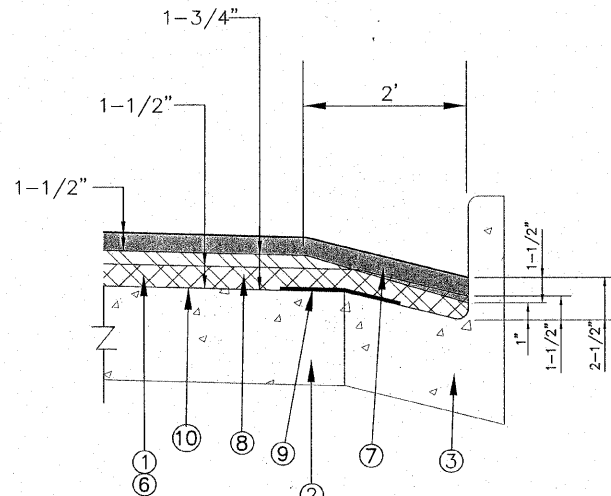

DETAIL A

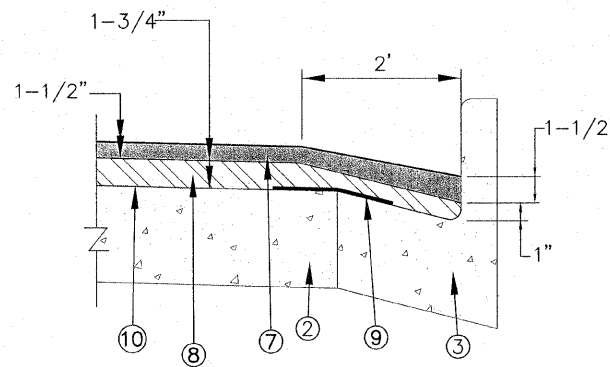

DETAIL B

LEGEND

- ① EXISTING HOT-MIX ASPHALT SURFACE, 1-1/2"
- ② EXISTING CONCRETE PAVEMENT, 7-1/2"
- ③ EXISTING COMBINATION CONCRETE CURB AND GUTTER, TYPE B-6.18
- ④ EXISTING PCC SIDEWALK 4'
- ⑤ EXISTING GROUND LINE
- ⑥ PROPOSED HOT-MIX ASPHALT SURFACE REMOVAL, 1-1/2"
- ⑦ PROPOSED HOT-MIX ASPHALT SURFACE COURSE, MIX"D", N70, 1-1/2"
- ⑧ PROPOSED LEVELING BINDER (MACHINE METHOD), N70, 1-3/4"
- ⑨ PROPOSED STRIP REFLECTIVE CRACK CONTROL
- ⑩ PROPOSED BITUMINOUS MATERIALS (PRIME COAT) & AGGREGATE (PRIME COAT)
- ⑪ PROPOSED HOT-MIX ASPHALT SURFACE REMOVAL- BUTT JOINT
- ⑫ EXISTING OIL AND CHIP SURFACE ON AN AGGREGATE BASE

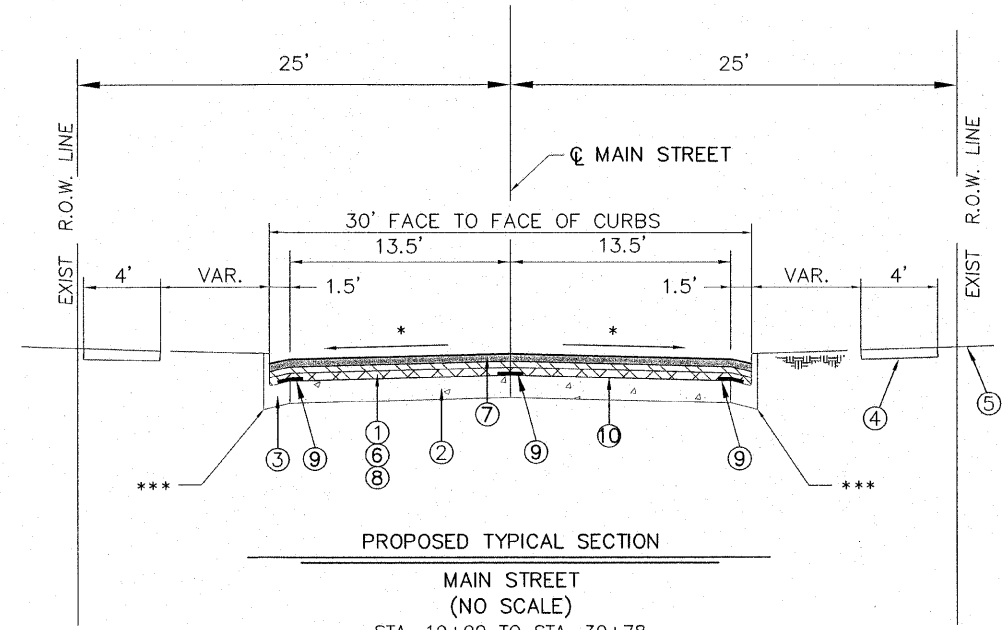

PROPOSED TYPICAL SECTION

**MAIN STREET
(NO SCALE)**
STA. 19+00 TO STA. 30+78
STA. 38+46 TO STA. 38+86

* MATCH EXISTING
*** SEE DETAIL A

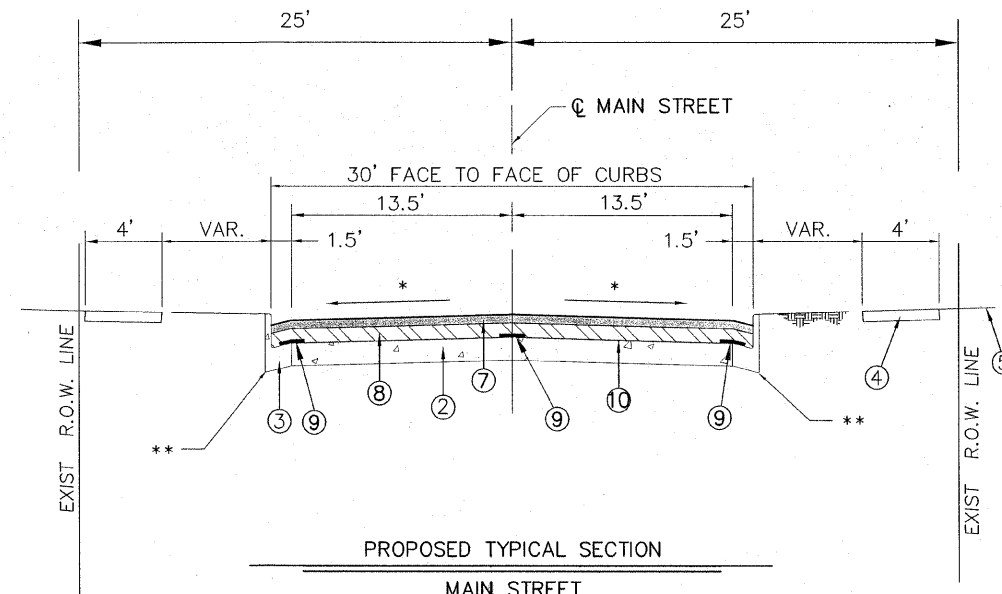

PROPOSED TYPICAL SECTION

**MAIN STREET
(NO SCALE)**
STA. 30+78 TO STA. 38+46

* MATCH EXISTING
** SEE DETAIL B

REVISIONS

SMS ENGINEERS
Sheppard, Morgan & Schwaab, Inc.
CONSULTING ENGINEERS AND LAND SURVEYORS
115 Market Street, P.O. Box E, Alton, IL 62002 • 618/622-9755 • Email: mail@smsengineers.com
10 Central Industrial Drive, Granite City, IL 62040 • 618/877-3700 • Email: mail@smsengineers.com

EAST ALTON, ILLINOIS - MAIN STREET IMPROVEMENTS
SECTION 09-00045-01-RS
FAU ROUTE 8967
TYPICAL SECTIONS AND CONSTRUCTION DETAILS

E ALTON CONST DETAILS.DWG
REF. BK. PG.
JOB NO. 227624.1
DSN. BY: LA
DWN. BY: CAD
CHK. BY: LA
DATE: MAY, 2009

SCALE: NONE

SHEET 3 OF 9