

F.A.P. RTE.	SECTION	COUNTY	TOTAL SHEETS	SHEET NO.
331	*	JACKSON	67	50
STA. _____		TO STA. _____		
FED. ROAD DIST. NO. _____		ILLINOIS FED. AID PROJECT		
* D9 BSMART FY10-1				

STATE OF ILLINOIS  
DEPARTMENT OF TRANSPORTATION

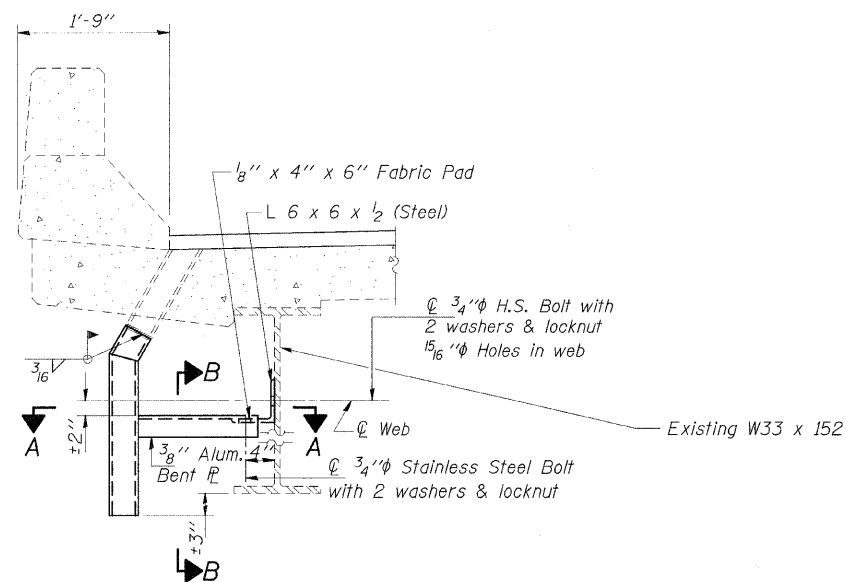

**SECTION AT DRAIN**

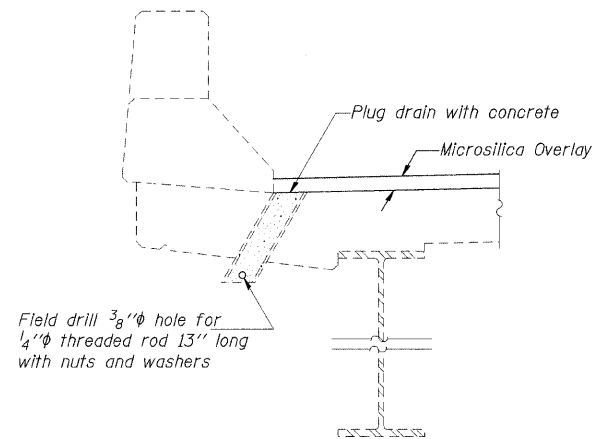

**DRAIN ELIMINATION DETAIL**  
( 28 Locations)

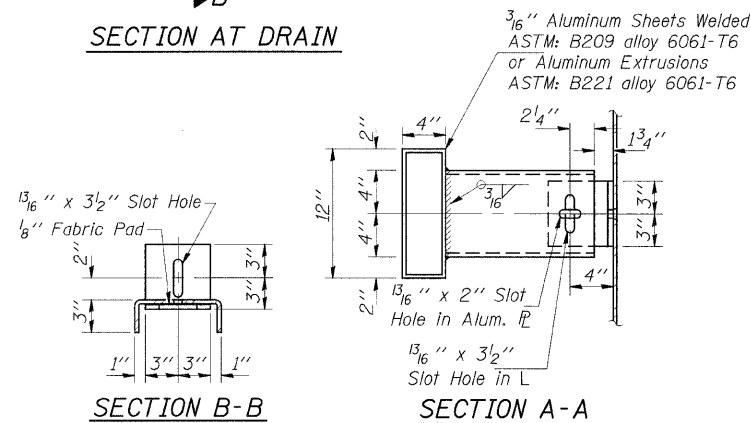

**DRAIN EXTENSION DETAIL**  
(26 locations)

PLOT DATE = 3/25/2009  
FILE NAME = c:\pwworkspace\pwworkspace\user\dms43846\dms43846.dgn  
USER NAME = portarc

**DRAIN DETAILS**  
**ILL 13 W.B. OVER MUD CREEK**  
**JACKSON COUNTY**  
**SN 039-0050**