

STATE OF ILLINOIS
DEPARTMENT OF TRANSPORTATION

F.A. RTE.	SECTION	COUNTY	TOTAL SHEETS	SHEET NO.
-	DIST 8 DEEP WELLS 2021-1	MADISON/ST. CLAIR	10	1
* = VARIOUS		ILLINOIS	CONTRACT NO. 76M78	

PROPOSED HIGHWAY PLANS

VARIOUS ROUTES SECTION DIST 8 DEEP WELLS 2021-1 WELL TREATMENT MADISON AND ST. CLAIR COUNTIES

C-98-111-19

INDEX OF SHEETS

- 1 COVER SHEET AND STANDARDS
- 2 GENERAL NOTES, COMMITMENTS AND ADT
- 3 SUMMARY OF QUANTITIES
- 4 LOCATION NO. 1: SITE PLAN VENICE WELLS (IL ROUTE 3)
- 5 LOCATION NO. 2: SITE PLAN TRI-LEVEL WELLS
- 6 LOCATION NO. 3: SITE PLAN MISSOURI AVENUE WELLS
- 7 LOCATION NO. 4: SITE PLAN 25TH ST. WELLS
- 8 WELL HOUSE BUILDING - CAISSON DETAILS
- 9 MISSOURI AVENUE DEEP WELL (LOCATION 3)
- 10 TYPICAL WELL DETAILS LOCATION 1
- 10 TYPICAL WELL DETAILS LOCATION 2, 3, 4

STANDARDS

- 000001-07
- 001006
- 701101-05
- 701106-02
- 701400-09
- 701401-12
- 701428-01
- 701601-09
- 701901-08

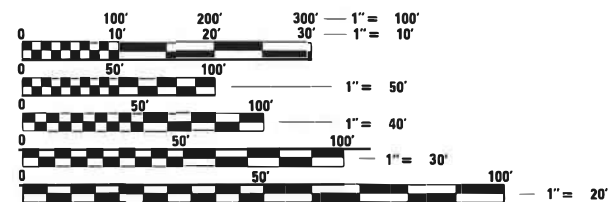

FULL SIZE PLANS HAVE BEEN PREPARED USING STANDARD ENGINEERING SCALES. REDUCED SIZED PLANS WILL NOT CONFORM TO STANDARD SCALES. IN MAKING MEASUREMENTS ON REDUCED PLANS, THE ABOVE SCALES MAY BE USED.

J.U.L.I.E.
JOINT UTILITY LOCATION INFORMATION FOR EXCAVATORS
1-800-892-0123
OR 811

PROJECT ENGINEER: HERVE GELIN (618) 346-3179
PROJECT MANAGER: PHILLIP PETE SAWYER (618) 346-3275
SQUAD LEADER: MICHAEL PRESTON (618) 346-3143
CONTRACT NO. 76M78

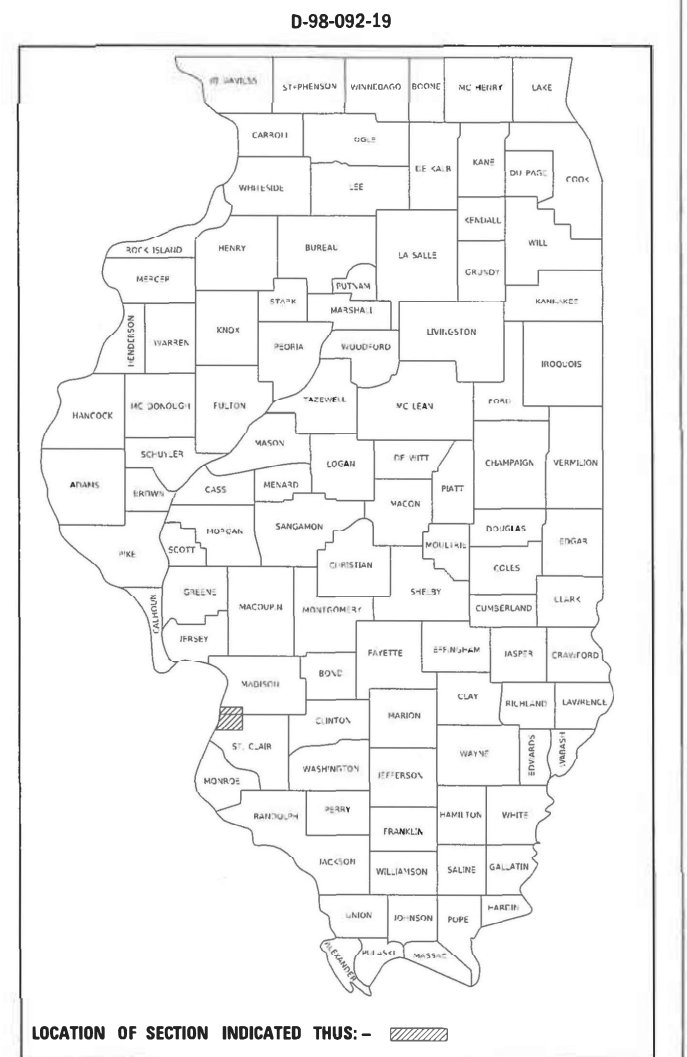
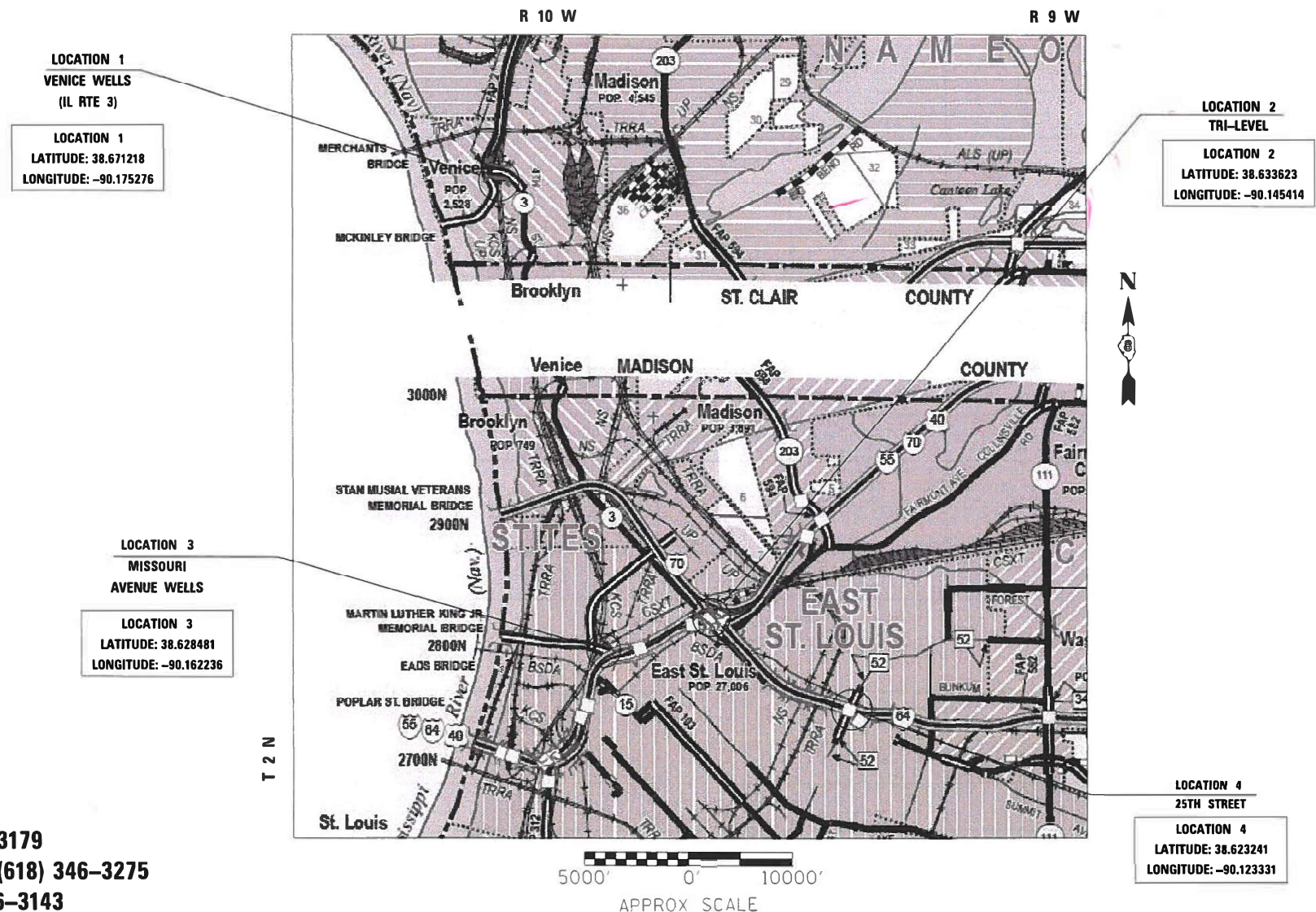

STATE OF ILLINOIS
DEPARTMENT OF TRANSPORTATION

SUBMITTED *June 26, 2020*
Ruth Roberts
REGIONAL ENGINEER

August 14, 2020
Scott A. Elk
ENGINEER OF DESIGN AND ENVIRONMENT

August 14, 2020
James J. Gu
DIRECTOR OF HIGHWAYS PROJECT IMPLEMENTATION

PRINTED BY THE AUTHORITY
OF THE STATE OF ILLINOIS

GENERAL NOTES

1. WHERE SECTION OR SUB-SECTION MONUMENTS ARE ENCOUNTERED, THE ENGINEER SHALL BE NOTIFIED BEFORE SUCH MONUMENTS ARE REMOVED. THE CONTRACTOR SHALL PROTECT AND CAREFULLY PRESERVE ALL PROPERTY MARKERS AND MONUMENTS UNTIL THE OWNER, AN AUTHORIZED SURVEYOR OR AGENT HAS WITNESSED OR OTHERWISE REFERENCED THE LOCATION.
2. ALL WELLS REQUIRE SEALING OF MISCELLANEOUS OPENINGS IN THE WELL HEAD TO PREVENT LEAKAGE DURING TREATMENT OPERATIONS. THIS WORK WILL NOT BE PAID FOR SEPARATELY, BUT WILL BE INCLUDED IN COST OF THE SPECIFIED TREATMENT METHODS.
3. THE DEPARTMENT RESERVES THE RIGHT TO NOTIFY THE CONTRACTOR TO CHANGE THE SEQUENCE OF WELL CLEANING IF NEEDED TO ENSURE PROPER DEWATERING NEEDS FOR THE DEPARTMENT. THE CONTRACTOR SHALL ALLOW 24 HOURS BETWEEN WELL TREATMENTS. THE CONTRACTOR SHALL INSTALL THE TEMPORARY DISCHARGE PIPES BACK INTO THE WELL DISCHARGE PIPES. ALL DISCHARGE WATER SHALL BE DISCHARGED INTO THE WELL FORCE MAINS.
4. THE DEPARTMENT STRONGLY ENCOURAGES THE PRIME CONTRACTOR AND THEIR APPROVED SUB-CONTRACTORS TO HIRE MINORITY, WOMEN AND DISADVANTAGED INDIVIDUALS FROM ITS FEDERALLY FUNDED HIGHWAY CONSTRUCTION CAREERS TRAINING PROGRAM (HCCTP) TO HELP MEET WORKFORCE AND TRAINEE GOALS. THIS PROGRAM IS TRAINING MINORITIES, WOMEN AND DISADVANTAGED INDIVIDUALS IN HIGHWAY CONSTRUCTION-RELATED SKILLS, E.G., MATH FOR THE TRADES, JOB READINESS, TECHNICAL SKILLS COURSEWORK (CARPENTRY, CONCRETE FLATWORK, BLUEPRINT READING, SITE PLANS, SITE WORK, TOOLS USE, ETC.) AND OSHA 10 HOUR CERTIFICATION, TO PREPARE THEM FOR A CAREER IN THE HIGHWAY CONSTRUCTION TRADES. GRADUATES ARE WELL-TRAINED AND READY TO BECOME PRODUCTIVE ENTRY-LEVEL CONSTRUCTION WORKERS. CONTACT THE DISTRICT 8 EEO OFFICE AT 618-346-3360 AND/OR THE HCCTP COORDINATOR AT 618-874-6528 TO LEARN MORE ABOUT THE PROGRAM AND FOR ASSISTANCE IN MEETING WORKFORCE AND TRAINEE GOALS.

FUNCTIONAL CLASSIFICATION
URBAN MINOR ARTERIAL

COMMITMENTS
NONE

LOCATION 1
NB/SB: 2020 ADT = 6500
S.U.=13.0% M.U.=7.9%

LOCATION 2
SB: 2020 ADT = 34900
S.U.=3.7% M.U.=11.1%
NB: 2020 ADT = 35400
S.U.=3.5% M.U.=10.4%

LOCATION 3
WB RAMP: 2020 ADT = 30000
S.U.=2.2% M.U.=7.3%
EB RAMP: 2020 ADT = 30000
S.U.=2.2% M.U.=7.3%

LOCATION 4
NB/SB: 2020 ADT = 7400
S.U.=4.1% M.U.=2.9%

**STATE OF ILLINOIS
DEPARTMENT OF TRANSPORTATION**

GENERAL NOTES, COMMITMENTS AND ADT

SCALE: SHEET OF SHEETS STA. TO STA.

F.A. RTE.	SECTION	COUNTY	TOTAL SHEETS	SHEET NO.
*	DIST 8 DEEP WELLS 2021-1	ST. CLAIR	10	2
* = VARIOUS		CONTRACT NO. 76M78		
		ILLINOIS	FED. AID PROJECT	

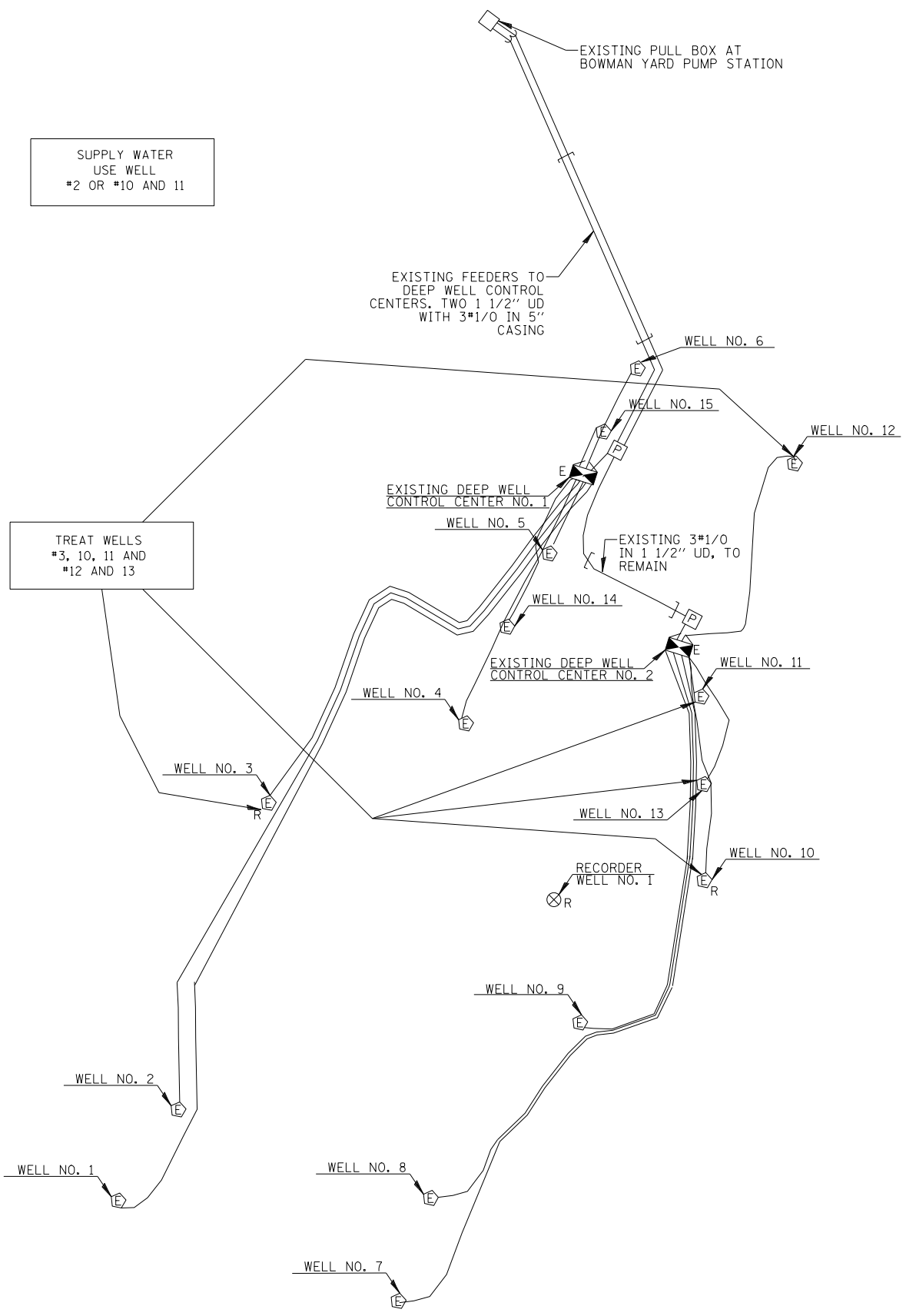
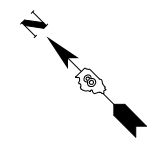

SUPPLY WATER
USE WELL
#2 OR #10 AND 11

TREAT WELLS
#3, 10, 11 AND
#12 AND 13

LOCATION	ADDITIONAL TREATMENT NO. 1	ADDITIONAL TREATMENT NO. 2	WELL CHEMICAL TREATMENT	SONAR JET TREATMENT	WELL CHEMICAL TREATMENT SPECIAL
WELL #3	X	X	X		
WELL #10	X	X		X	
WELL #11	X	X	X		
WELL #12B	X	X	X		
WELL #13	X	X	X		



MODEL: Default
 FILE: \\nrcr-pc\pub\lancorn.dwg
 PROJECT: \\nrcr-pc\pub\lancorn.dwg
 OFFICE: \\nrcr-pc\pub\lancorn.dwg
 DATE: 6/25/2020

USER NAME = prestonme	DESIGNED -	REVISED -
	DRAWN -	REVISED -
PLOT SCALE = 100.0000' / in.	CHECKED -	REVISED -
PLOT DATE = 6/25/2020	DATE -	REVISED -

**STATE OF ILLINOIS
DEPARTMENT OF TRANSPORTATION**

LOCATION NO. 2: SITE PLAN TRI-LEVEL WELLS				
SCALE:	SHEET	OF	SHEETS	STA. TO STA.

F.A. RTE.	SECTION	COUNTY	TOTAL SHEETS	SHEET NO.
*	DIST 8 DEEP WELLS 2021-1	ST. CLAIR	10	5
* = VARIOUS		CONTRACT NO. 76M78		
		ILLINOIS FED. AID PROJECT		

MODEL: Default
 FILE: \\nrc\p\pub\lansroom.d\illinois.gov\PWIDOT\Documents\DOT_Offices\District 8\Projects\ID076M78\CADD\Drawn\Electrical\ID076M78-elec.dgn

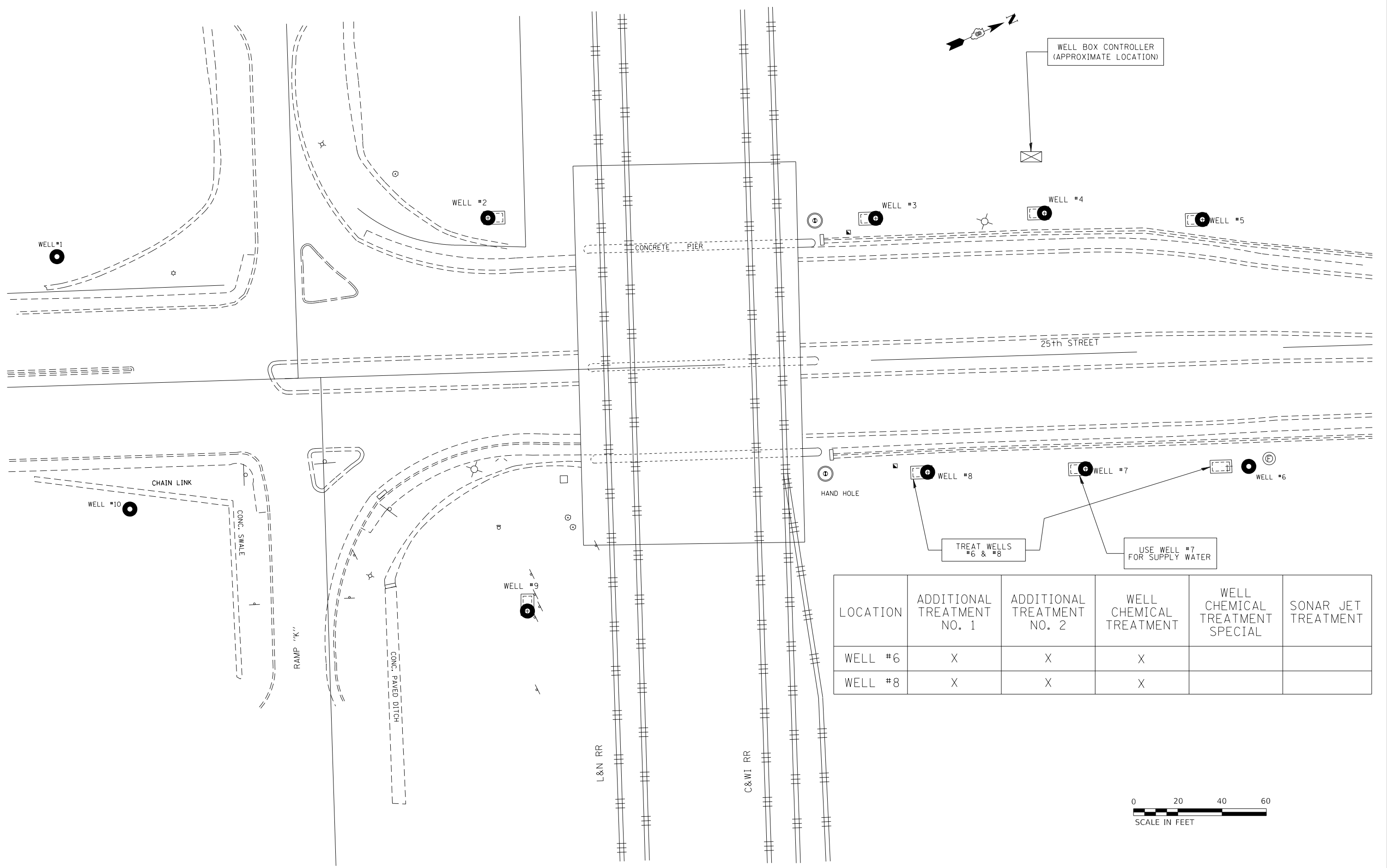

LOCATION	ADDITIONAL TREATMENT NO. 1	ADDITIONAL TREATMENT NO. 2	WELL CHEMICAL TREATMENT	WELL CHEMICAL TREATMENT SPECIAL	SONAR JET TREATMENT
WELL #6	X	X	X		
WELL #8	X	X	X		



USER NAME = prestonme	DESIGNED -	REVISED -
	DRAWN -	REVISED -
PLOT SCALE = 100,0000' / in.	CHECKED -	REVISED -
PLOT DATE = 6/25/2020	DATE -	REVISED -

**STATE OF ILLINOIS
 DEPARTMENT OF TRANSPORTATION**

**LOCATION NO. 4: SITE PLAN
 25TH ST. WELLS**

SCALE: SHEET OF SHEETS STA. TO STA.

F.A. RTE.	SECTION	COUNTY	TOTAL SHEETS	SHEET NO.
*	DIST 8 DEEP WELLS 2020-1	ST. CLAIR	10	7
* = VARIOUS		CONTRACT NO. 76M78		
		ILLINOIS	FED. AID PROJECT	

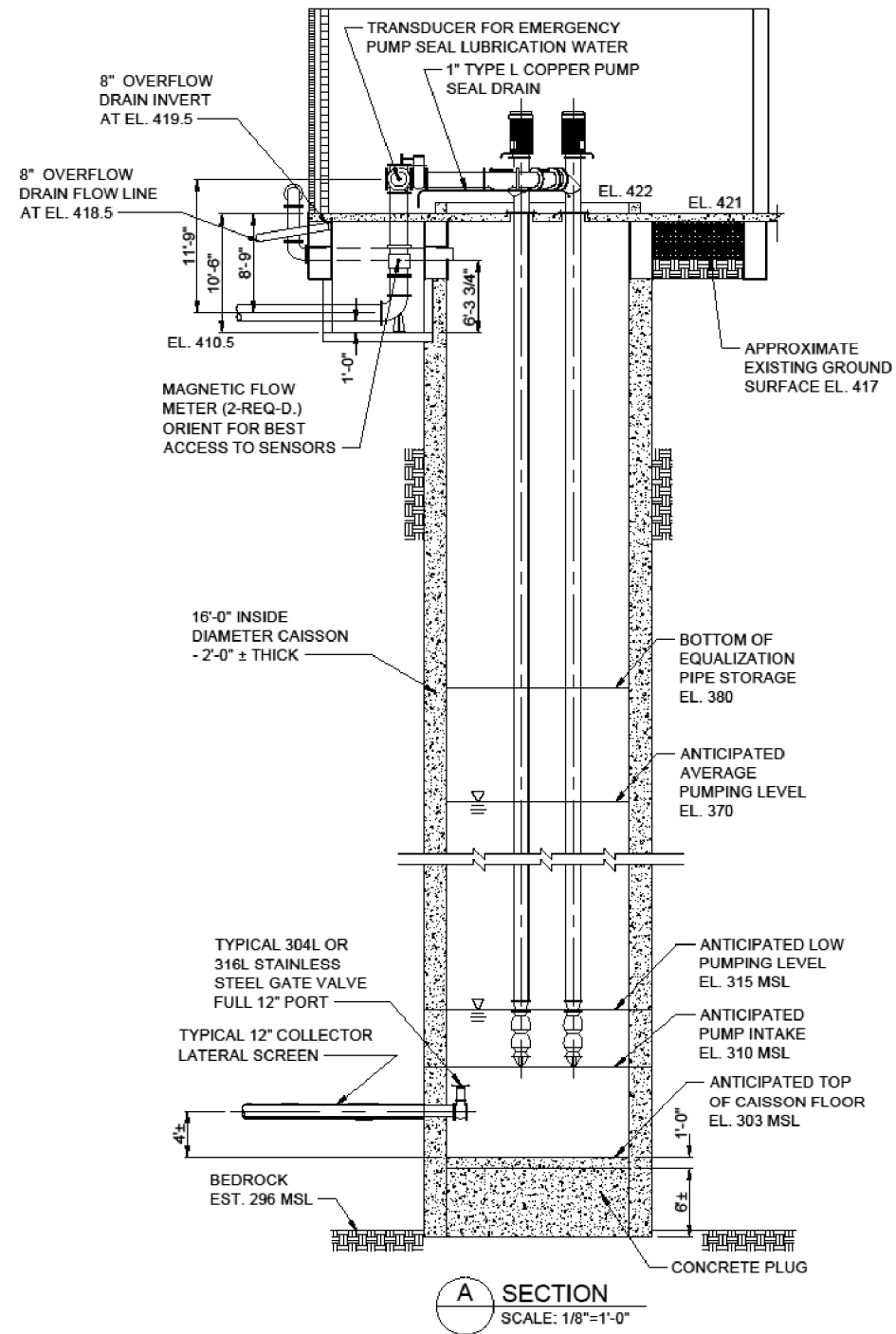

MODEL: Default
 FILE: Model: Pic: Up: Room: dat: Illinois.gov: PWIDOT: Documents: IDOT: Offices: District: 8: Projects: DIST 8: CAISSON: Electrical: DIST 8: 76M78: elec.dgn

USER NAME = prestonme	DESIGNED -	REVISED -
	DRAWN -	REVISED -
PLOT SCALE = 100,0000' / in.	CHECKED -	REVISED -
PLOT DATE = 6/25/2020	DATE -	REVISED -

**STATE OF ILLINOIS
 DEPARTMENT OF TRANSPORTATION**

**WELL HOUSE BUILDING - CAISSON DETAILS
 MISSOURI AVE DEEP WELL (LOCATION 3)**

SCALE: SHEET OF SHEETS STA. TO STA.

F.A. RTE.	SECTION	COUNTY	TOTAL SHEETS	SHEET NO.
*	DIST 8 DEEP WELLS 2021-1	ST. CLAIR	10	8
* = VARIOUS		CONTRACT NO. 76M78		
		ILLINOIS	FED. AID PROJECT	

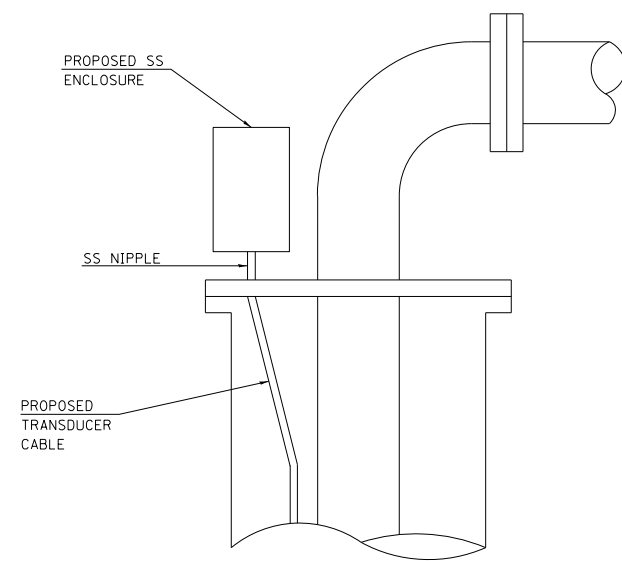

WELL HEAD DETAIL

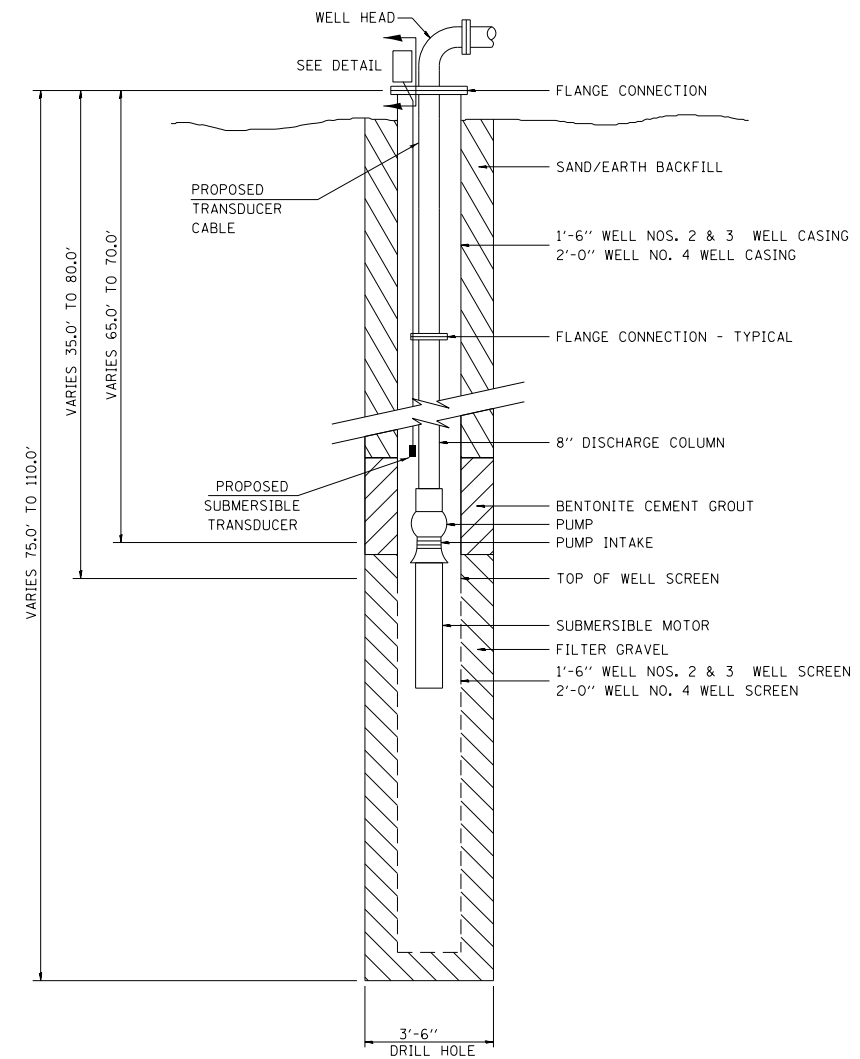

EXISTING

NOT TO SCALE

MODEL: Default
FILE: Model: P:\pub\planroom.dwg
PROJECT: I:\projects\DOT\Documents\DOT - Offices\District 8\Projects\Dist8\76M78\CA\Draws\Electrical\0876M78-elec.dwg

USER NAME = prestonme	DESIGNED -	REVISED -
	DRAWN -	REVISED -
PLOT SCALE = 100.0000' / in.	CHECKED -	REVISED -
PLOT DATE = 6/25/2020	DATE -	REVISED -

STATE OF ILLINOIS
DEPARTMENT OF TRANSPORTATION

TYPICAL WELL DETAILS LOCATION 1

SCALE: SHEET OF SHEETS STA. TO STA.

F.A. RTE.	SECTION	COUNTY	TOTAL SHEETS	SHEET NO.
*	DIST 8 DEEP WELLS 2021-1	ST. CLAIR	10	9
* = VARIOUS		CONTRACT NO. 76M78		
		ILLINOIS FED. AID PROJECT		

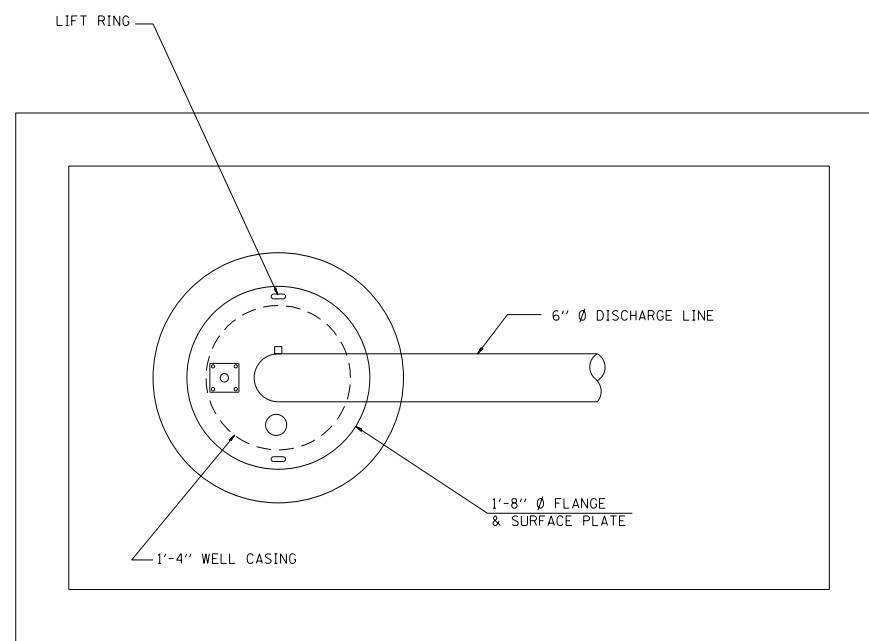

WELL HEAD DETAIL

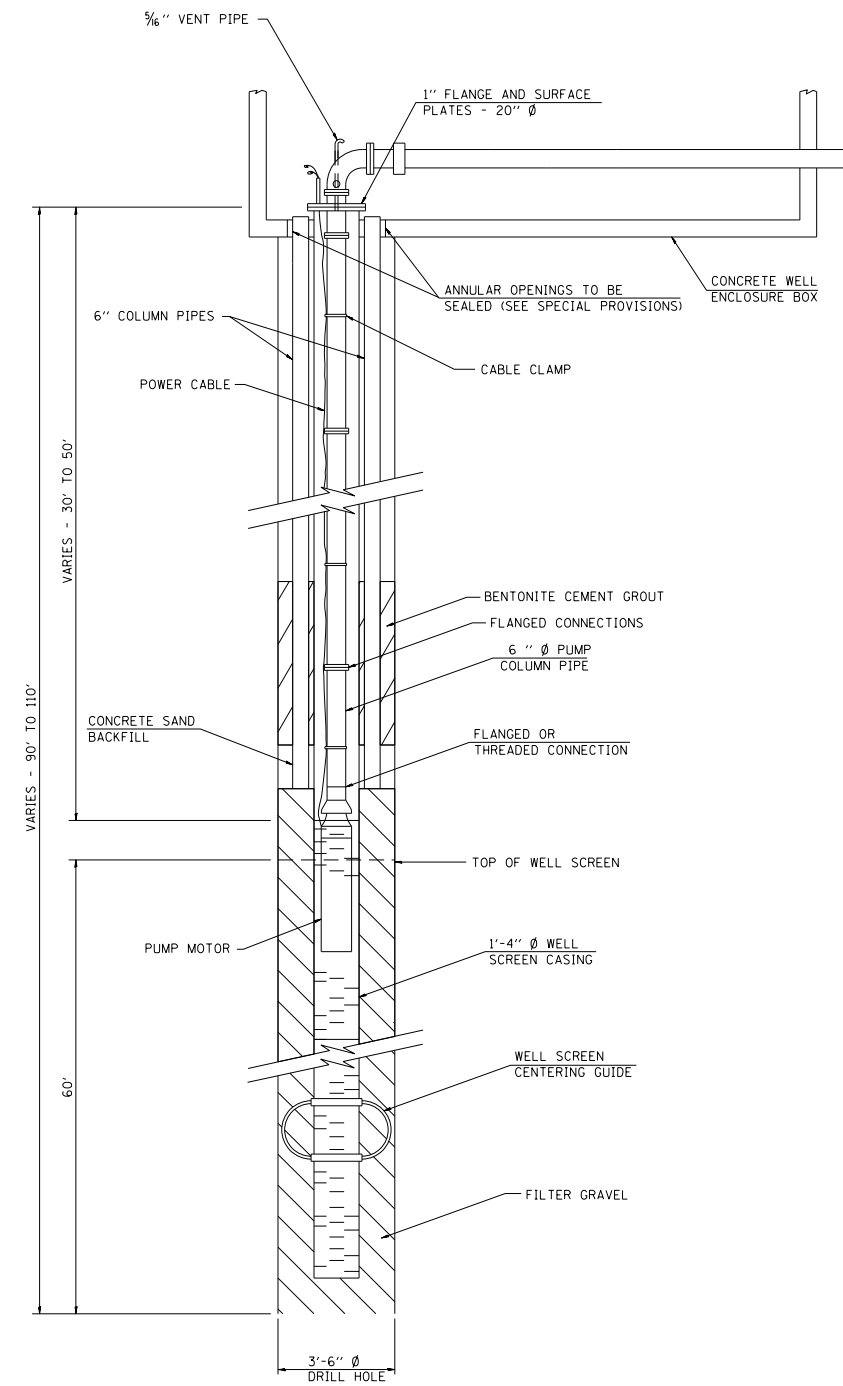

EXISTING

NOT TO SCALE

MODEL: Default
FILE: Model2_Plan\planroom.dwg
PROJECT: 076M78\CD\Draws\Electrical\076M78-elec.dwg

USER NAME = prestonme	DESIGNED -	REVISED -
PLOT SCALE = 100,0000' / in.	DRAWN -	REVISED -
PLOT DATE = 6/25/2020	CHECKED -	REVISED -
	DATE -	REVISED -

STATE OF ILLINOIS
DEPARTMENT OF TRANSPORTATION

TYPICAL WELL DETAILS LOCATION 2, 3, 4

SCALE: SHEET OF SHEETS STA. TO STA.

F.A. RTE.	SECTION	COUNTY	TOTAL SHEETS	SHEET NO.
*	DIST 8 DEEP WELLS 2021-1	ST. CLAIR	10	10
* = VARIOUS		CONTRACT NO. 76M78		
		ILLINOIS	FED. AID PROJECT	