

### CONTROLLER SEQUENCE

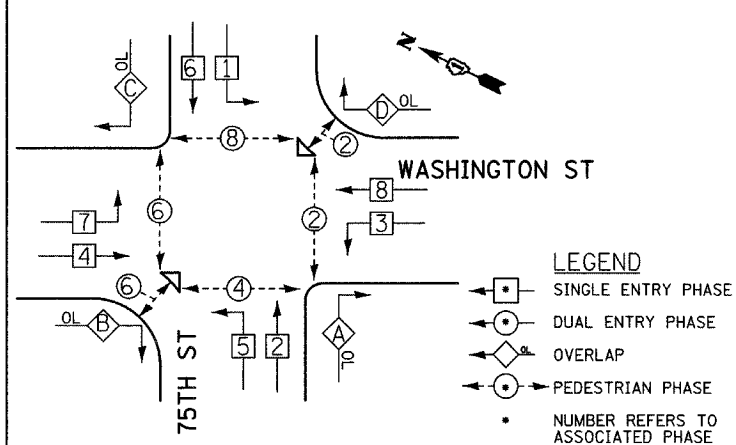

**LEGEND**

- SINGLE ENTRY PHASE
- ◐ DUAL ENTRY PHASE
- ◑ OVERLAP
- ◒ PEDESTRIAN PHASE
- NUMBER REFERS TO ASSOCIATED PHASE

### PHASE DESIGNATION DIAGRAM

#### RIGHT TURN OVERLAP PHASE DESIGNATION

OVERLAP LETTER	PERMISSIVE PHASE	PROTECTED PHASE
A	= 2	+ 3
B	= 4	+ 5
C	= 6	+ 7
D	= 8	+ 1

### EMERGENCY VEHICLE PREEMPTION SEQUENCE

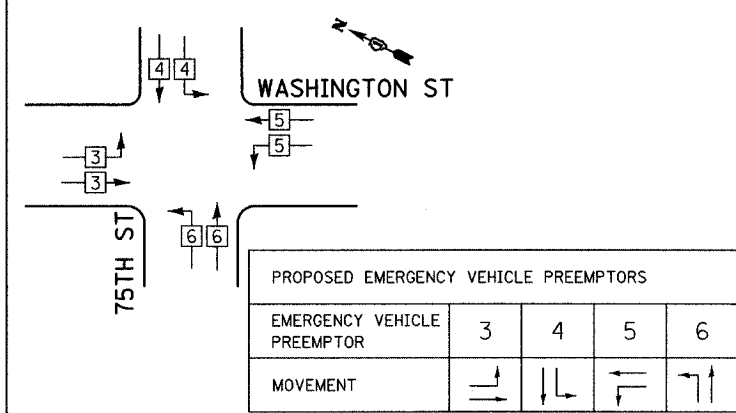

### SCHEDULE OF QUANTITIES

PAY ITEM	UNIT	QTY
SIGN PANEL - TYPE 1	SQ FT	40
CONDUIT IN TRENCH, 2" DIA., GALVANIZED STEEL	FOOT	848
CONDUIT IN TRENCH, 2 1/2" DIA., GALVANIZED STEEL	FOOT	101
CONDUIT IN TRENCH, 3" DIA., GALVANIZED STEEL	FOOT	16
CONDUIT IN TRENCH, 3 1/2" DIA., GALVANIZED STEEL	FOOT	13
CONDUIT IN TRENCH, 5" DIA., GALVANIZED STEEL	FOOT	112
CONDUIT IN TRENCH, 6" DIA., GALVANIZED STEEL	FOOT	10
CONDUIT PUSHED, 4" DIA., GALVANIZED STEEL	FOOT	163
CONDUIT PUSHED, 5" DIA., GALVANIZED STEEL	FOOT	155
CONDUIT PUSHED, 6" DIA., GALVANIZED STEEL	FOOT	197
JUNCTION BOX, STAINLESS STEEL, ATTACHED TO STRUCTURE, 6" X 6" X 4"	EACH	2
HANDHOLE	EACH	7
HEAVY-DUTY HANDHOLE	EACH	2
DOUBLE HANDHOLE	EACH	5
TRENCH AND BACKFILL FOR ELECTRIC WORK	FOOT	1060
FULL-ACTUATED CONTROLLER AND TYPE V CABINET, SPECIAL	EACH	1
MASTER CONTROLLER	EACH	1
TRANSCEIVER - FIBER OPTIC	EACH	1
ELECTRIC CABLE IN CONDUIT, SIGNAL NO. 14 2C	FOOT	3598
ELECTRIC CABLE IN CONDUIT, SIGNAL NO. 14 3C	FOOT	5192
ELECTRIC CABLE IN CONDUIT, SIGNAL NO. 14 5C	FOOT	4581
ELECTRIC CABLE IN CONDUIT, SIGNAL NO. 14 7C	FOOT	2939
ELECTRIC CABLE IN CONDUIT, LEAD-IN, NO. 14 1 PAIR	FOOT	8526
ELECTRIC CABLE IN CONDUIT, SERVICE, NO. 6 2C	FOOT	72
TRAFFIC SIGNAL POST, GALVANIZED STEEL, 16 FT	EACH	2
STEEL MAST ARM ASSEMBLY AND POLE, 24 FT	EACH	1
STEEL MAST ARM ASSEMBLY AND POLE, 55 FT	EACH	1
STEEL COMBINATION MAST ARM ASSEMBLY AND POLE, 24 FT.	EACH	2
STEEL COMBINATION MAST ARM ASSEMBLY AND POLE, 55 FT.	EACH	1
CONCRETE FOUNDATION, TYPE A	FOOT	8
CONCRETE FOUNDATION, TYPE C	FOOT	4
CONCRETE FOUNDATION, TYPE E 30-INCH DIAMETER	FOOT	30
CONCRETE FOUNDATION, TYPE E 36-INCH DIAMETER	FOOT	60
SIGNAL HEAD, POLYCARBONATE, LED, 1-FACE, 3-SECTION, MAST ARM MOUNTED	EACH	4
SIGNAL HEAD, POLYCARBONATE, LED, 1-FACE, 5-SECTION, BRACKET MOUNTED	EACH	8
SIGNAL HEAD, POLYCARBONATE, LED, 1-FACE, 5-SECTION, MAST ARM MOUNTED	EACH	6
PEDESTRIAN SIGNAL HEAD, POLYCARBONATE, LED, 1-FACE, BRACKET MOUNTED	EACH	2
PEDESTRIAN SIGNAL HEAD, POLYCARBONATE, LED, 3-FACE, BRACKET MOUNTED	EACH	2
TRAFFIC SIGNAL BACKPLATE	EACH	16
INDUCTIVE LOOP DETECTOR	EACH	20
DETECTOR LOOP, TYPE 1	FOOT	1051
LIGHT DETECTOR	EACH	4
LIGHT DETECTOR AMPLIFIER	EACH	1
PEDESTRIAN PUSH BUTTON	EACH	12
TEMPORARY TRAFFIC SIGNAL INSTALLATION	EACH	1
REMOVE EXISTING TRAFFIC SIGNAL EQUIPMENT	EACH	1
REMOVE EXISTING HANDHOLE	EACH	7
REMOVE EXISTING CONCRETE FOUNDATION	EACH	12
COAXIAL CABLE IN CONDUIT	FOOT	155
VIDEO VEHICLE DETECTOR	EACH	1
TEMPORARY TRAFFIC SIGNAL TIMINGS	EACH	1
SERVICE INSTALLATION - GROUND MOUNTED	EACH	1
ELECTRIC CABLE IN CONDUIT, GROUNDING, NO. 6 1C	FOOT	933
ELECTRIC CABLE IN CONDUIT, NO. 20 3/C, TWISTED, SHIELDED	FOOT	1466
UNINTERRUPTABLE POWER SUPPLY	EACH	1
COMBINATION STEEL MAST ARM ASSEMBLY AND POLE WITH DUAL MAST ARMS 24 FT AND 54 FT	EACH	2

### NOTES:

1. THE END OF THE TRACER CABLE SHALL BE CONTINUOUS AND EXTEND INTO THE CONTROLLER CABINET.

FOUNDATION (DEPTH)	FT. (m)	CABLE SLACK	FT. (m)	VERTICAL	FT. (m)	
TYPE A - POST	4 (1.2)	HANDHOLE	6.5 (2.0)	ALL FOUNDATIONS	3.5 (1.0)	
D - CONTROLLER	4 (1.2)	DOUBLE HANDHOLE	13 (4.0)	MAST ARM (L) POLE	20'+ L-2 = (6m+L-0.6m)	
E - MAST ARM POLE		SIGNAL POST	2 (1.0)	BRACKET MOUNTED	13 (4.0)	
	24" (600mm)	10 (3.0)	CONTROLLER CAB.	1 (0.5)	PED. PUSHBUTTON	4 (1.2)
	30" (750mm)	15 (4.6)	FIBER OPTIC	13 (4.0)	ELECTRIC SERVICE	13.5 (4.1)
			ELECTRIC SERVICE	1 (0.5)	SERVICE TO GROUND	13.5 (4.1)
			GROUND CABLE	1 (0.5)	POST MOUNTED	6 (1.8)

I.D.O.T. TRAFFIC SIGNAL INSTALLATION ELECTRICAL SERVICE REQUIREMENTS					
TYPE	NO. OF LAMPS	WATTAGE		% OPERATIONS	TOTAL WATTAGE
		INCAND.	LED		
SIGNAL (RED)	18	135	17	0.50	119
(YELLOW)	18	135	25	0.25	87.5
(GREEN)	18	135	15	0.25	52.5
ARROW	44	135	12	0.10	28.8
PED. SIGNAL	12	90	25	1.00	275
CONTROLLER	1	100	100	1.00	100
ILLUM. SIGN	4			0.05	0
FLASHER	0			0.05	0
ENERGY COSTS TO:					TOTAL = 662.8
CITY OF NAPERVILLE					
ENERGY SUPPLY: CONTACT: _____					
PHONE: _____					
COMPANY: CITY OF NAPERVILLE - DPU-E					

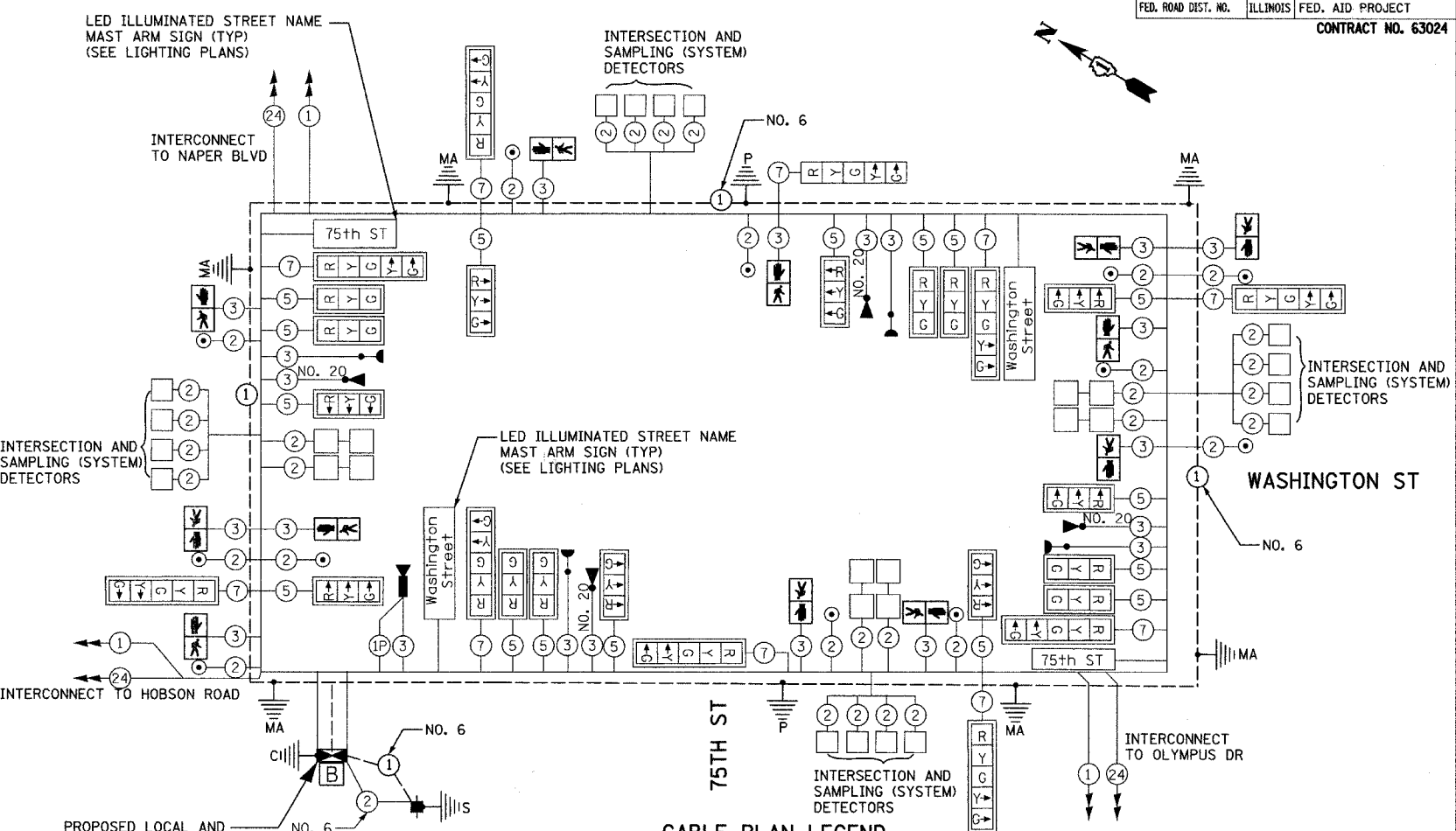

### CABLE PLAN LEGEND

EXISTING	PROPOSED	DESCRIPTION
⊗	⊗	8" (200mm) TRAFFIC SIGNAL SECTION
⊗	⊗	12" (300mm) TRAFFIC SIGNAL SECTION
⊗	⊗	12" (300mm) PEDESTRIAN SIGNAL SECTION
⊗	⊗	12" (300mm) PEDESTRIAN SIGNAL SECTION
⊗	⊗	CONTROLLER CABINET
⊗	⊗	SERVICE INSTALLATION
⊗	⊗	TELEPHONE CONNECTION
⊗	⊗	MAGNETIC DETECTOR
⊗	⊗	EMERGENCY VEHICLE LIGHT DETECTOR
⊗	⊗	CONFIRMATION BEACON
⊗	⊗	PUSHBUTTON DETECTOR
⊗	⊗	VEHICLE DETECTOR, INDUCTION LOOP
⊗	⊗	2 DENOTES NUMBER OF CONDUCTORS, ALL CABLE NO. 14 EXCEPT AS INDICATED. ALL LOOP DETECTOR CABLE TO BE SHIELDED.
⊗	⊗	SIGNAL FACE WITH BACKPLATE "P" INDICATES PROGRAMMED HEAD
H/C	H/C	GROUND ROD AT HANDHOLE, DOUBLE HANDHOLE, OR CONTROLLER
P	P	GROUND ROD AT POST OR MAST ARM POLE
S	S	GROUND ROD AT ELECTRIC SERVICE INSTALLATION
⊗	⊗	⊗ GROUND CABLE IN CONDUIT, NO.6 SOLID COPPER (GREEN)
⊗	⊗	⊗ FIBER OPTIC CABLE IN CONDUIT, NO. 62.5/125 2-MM12F & SM12F
⊗	⊗	⊗ UNINTERRUPTABLE POWER SUPPLY

REVISIONS	
NAME	DATE

**INTERSECTION IMPROVEMENT  
WASHINGTON STREET - 75th STREET  
SCHEDULE OF QUANTITIES, CABLE PLAN  
AND PHASE DESIGNATION DIAGRAM  
WASHINGTON STREET AND 75th STREET**

SHEET 4 OF 4

**TYLIN INTERNATIONAL**

City of **Naperville**

DRAWN: CBS SHEET NO. \_\_\_\_\_

CHECKED: \_\_\_\_\_

APPROVED: \_\_\_\_\_

DATE: APRIL 11, 2008

SCALE: NONE

JOB NO.: P-91-494-00 PROJECT NO.: M-CMM-7003 (985)

4/11/2008 10:51:59 AM