

FAU RTE	SECTION	COUNTY	TOTAL SHEETS	SHEET NO.
59th ST./DOUGLAS AVE.	08-00062-00-RS	COOK	10	10

CONTRACT NO. 63071

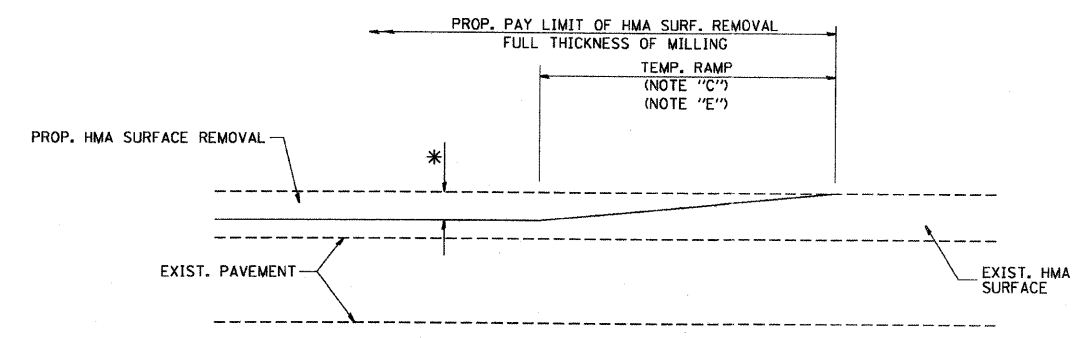

MILLED TEMPORARY RAMP
(FOR BUTT JOINT AND HMA TAPER SEE DETAIL BELOW)

OPTION 1

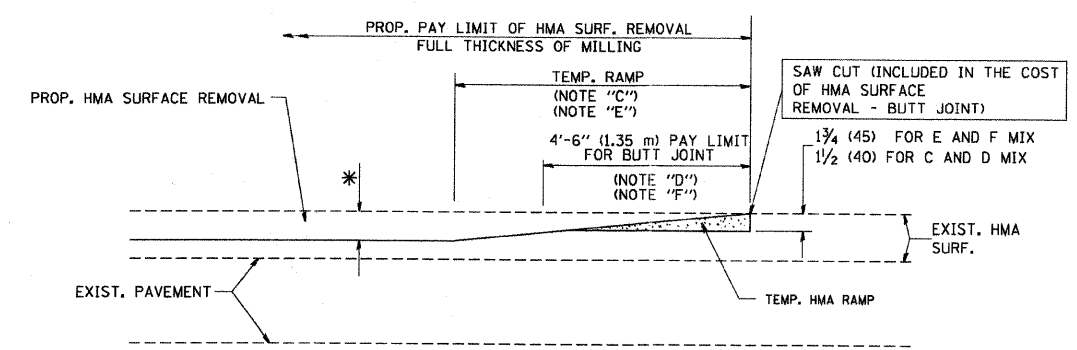

HMA CONSTRUCTED TEMPORARY RAMP
(FOR BUTT JOINT AND HMA TAPER SEE DETAIL BELOW)

OPTION 2
TYPICAL TEMPORARY RAMP

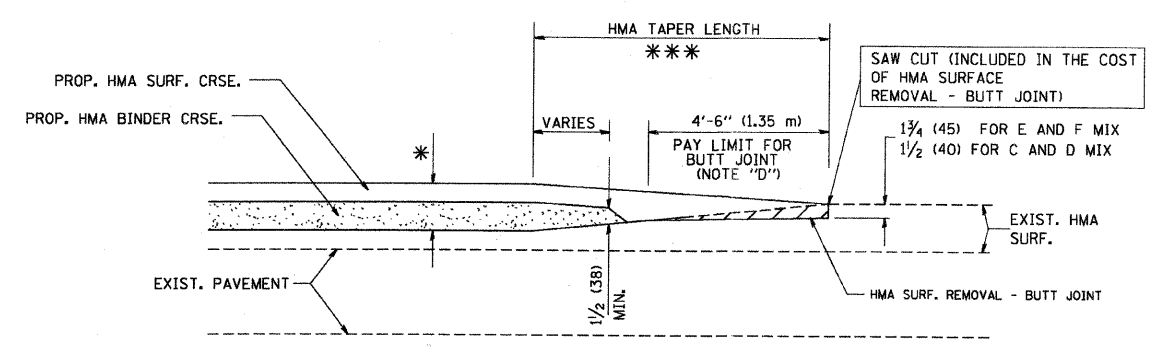

BUTT JOINT AND HMA TAPER

TYPICAL BUTT JOINT AND HMA TAPER
FOR MILLING AND RESURFACING

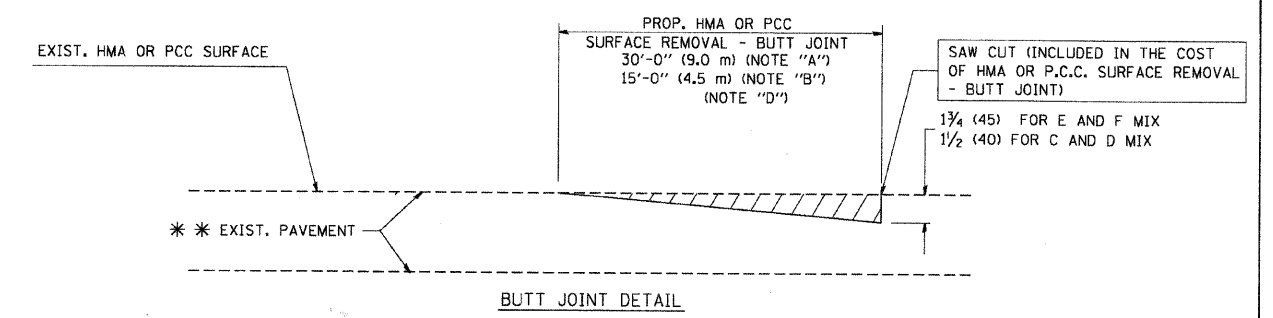

BUTT JOINT DETAIL

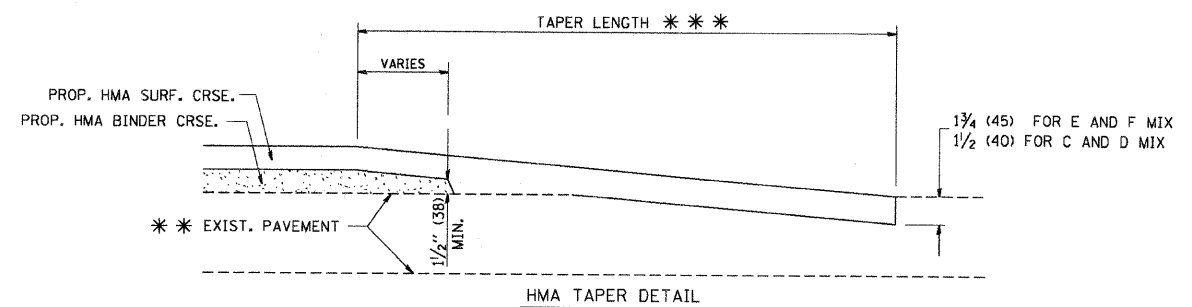

HMA TAPER DETAIL

TYPICAL BUTT JOINT AND HMA TAPER
FOR RESURFACING ONLY

** PC CONCRETE, HMA OR HMA RESURFACED PAVEMENT.

NOTES

- A: MAINLINE ROADWAYS AND MAJOR SIDE ROADS.
 - B: MINOR SIDE ROADS.
 - C: THE TEMP. RAMP SHALL BE CONSTRUCTED IMMEDIATELY UPON REMOVAL OF THE EXISTING HMA SURFACE.
 - D: THE BUTT JOINT SHALL BE CONSTRUCTED IMMEDIATELY PRIOR TO PLACING THE PROPOSED HMA COURSES.
 - E: TAPER THE TEMP. RAMP AT A RATE OF 3'-0" (900 mm) PER 1 INCH (25 mm) OF MILLING THICKNESS.
 - F: INSTALLATION AND REMOVAL OF THE 4'-6" (1.35 m) TEMP. RAMP IS INCLUDED IN COST OF HMA SURFACE REMOVAL - BUTT JOINT
 - G: SEE ARTICLE 406.08 AND 406.14 OF THE STANDARD SPECIFICATIONS FOR "HMA AND/OR PCC SURFACE REMOVAL, BUTT JOINT".
- * SEE TYPICAL SECTIONS FOR MILLING THICKNESS.
- ** 20'-0" (6.1 m) PER 1 (25) RESURFACING (NOTE "A")
10'-0" (3.0 m) PER 1 (25) RESURFACING (NOTE "B")

ALL DIMENSIONS ARE IN INCHES (MILLIMETERS) UNLESS OTHERWISE SHOWN.

BASIS OF PAYMENT:

THE BUTT JOINT WILL BE PAID FOR AT THE CONTRACT UNIT PRICE PER SQUARE YARD (SQUARE METER) FOR "HOT-MIX ASPHALT SURFACE REMOVAL - BUTT JOINT" OR FOR "PORTLAND CEMENT CONCRETE SURFACE REMOVAL - BUTT JOINT".

REVISIONS	
NAME	DATE
M. DE YONG	6-13-90
M. DE YONG	7-3-90
M. DE YONG	3-27-92
R. SHAH	09/09/94
R. SHAH	10/25/94
A. ABBAS	03/21/97
M. GOMEZ	04/06/01
R. BORO	01/01/07

ILLINOIS DEPARTMENT OF TRANSPORTATION

BUTT JOINT AND HMA TAPER DETAILS

SCALE: VERT. NONE
HORIZ. NONE

DRAWN BY
CHECKED BY

BD400-05 (VI-BD32)

PLOT DATE = 3/16/2007
FILE NAME = K:\projects\bd32.dgn
PLOT SCALE = 0.8000 / 1 IN.
USER NAME = bboard

Frank Novotny & Associates, Inc.
Civil Engineers/
Municipal Consultants
825 Midway Drive ♦ Willowbrook, IL ♦ 60527 ♦ Telephone: (630) 887-8640 ♦ Fax: (630) 887-0132
Illinois Professional Design Firm No. 184-000928

PROJECT
VILLAGE OF SUMMIT, ILLINOIS
L.A.P.P. RESURFACING
MFT SECTION NO. 08-00062-00-RS

REVISIONS			
NO.	BY	DATE	DESCRIPTION

BUTT JOINT AND HMA TAPER DETAILS

PROJECT NO. 07371	SCALE NONE	SHEET 10
DRAWN/DESIGNED JFP/JLC	DATE MAY, 2008	OF 10
CHECKED/APPROVED JLC	FIELD BOOK NO. FILE	SHEETS