

FOUNDATION LAYOUT

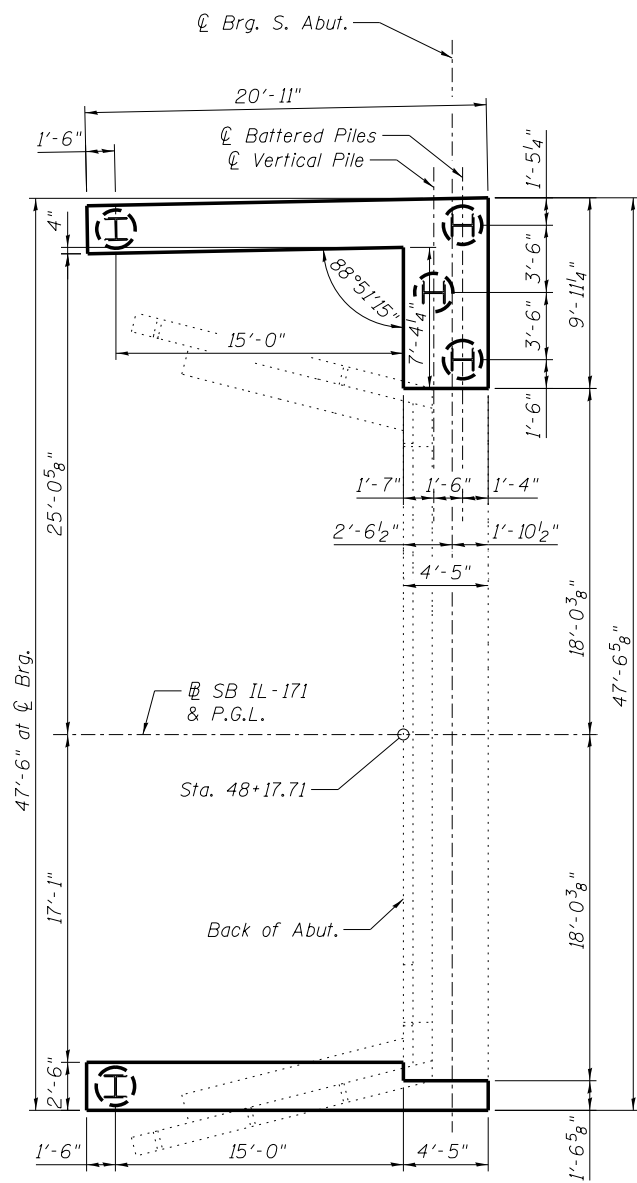

EXISTING SOUTH ABUTMENT

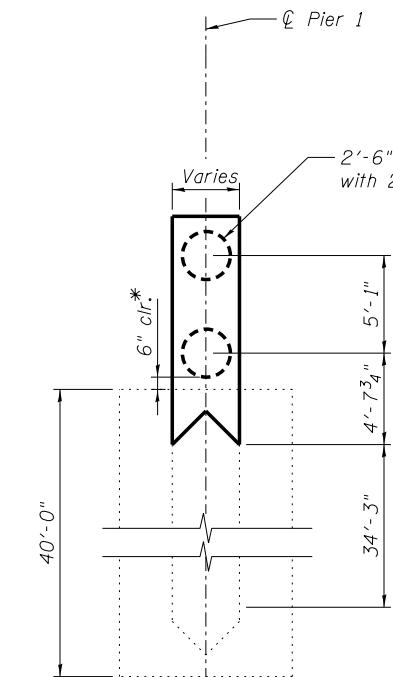

PIER 1 FOUNDATION PLAN

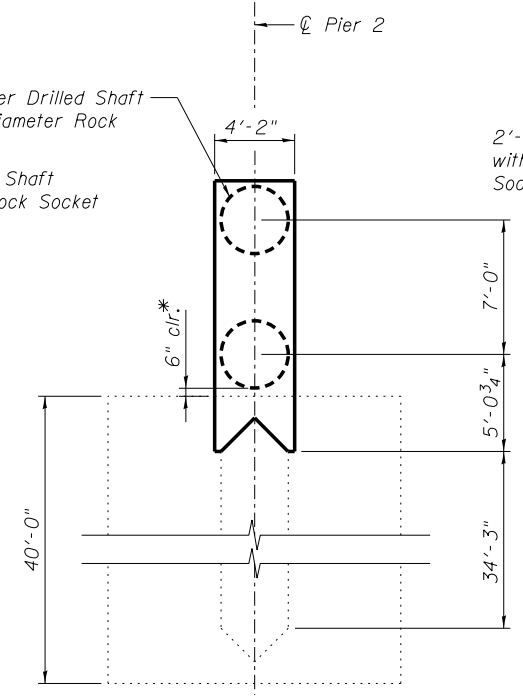

PIER 2 FOUNDATION PLAN

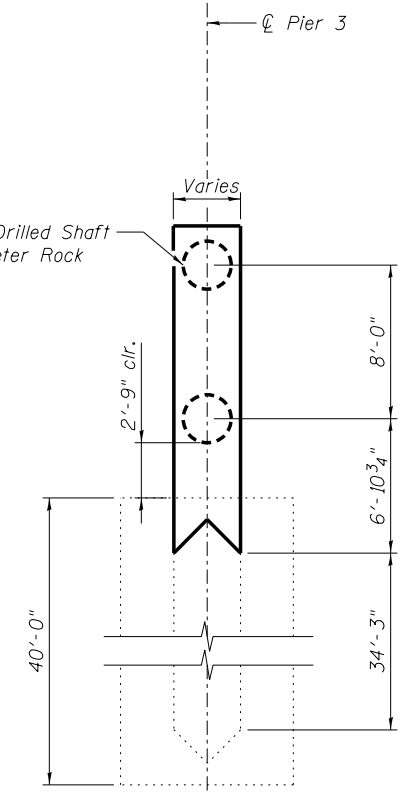

PIER 3 FOUNDATION PLAN

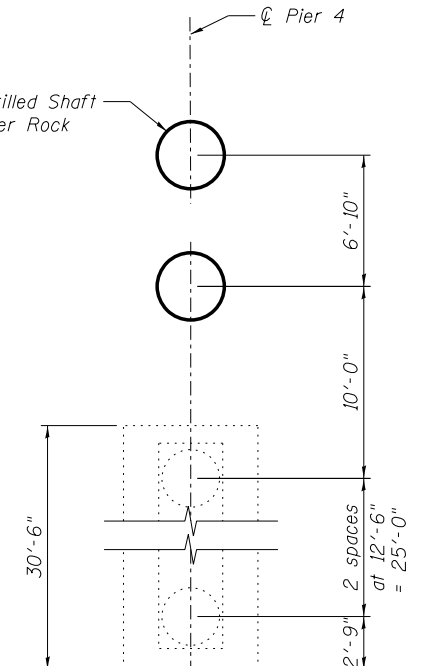

PIER 4 FOUNDATION PLAN

*Contractor shall probe to verify the edge of existing footing prior to constructing drilled shafts. Cost of probing shall be included with "Drilled Shaft in Soil".

benesch
engineers · scientists · planners
Alfred Benesch & Company
205 North Michigan Avenue, Suite 2400
Chicago, Illinois 60601
312-565-0450 Job No. 10093

FILE NAME =	USER NAME = jsurber	DESIGNED - TJJ	REVISED -
0160483.60J16.003.FndnLayout.dgn		CHECKED - AJK	REVISED -
		DRAWN - KMS	REVISED -
		CHECKED - AJK	REVISED -

**STATE OF ILLINOIS
DEPARTMENT OF TRANSPORTATION**

**FOUNDATION LAYOUT
STRUCTURE NO. 016-0483**

SHEET NO. SE3 OF SE46 SHEETS

F.A.P. RTE.	SECTION	COUNTY	TOTAL SHEETS	SHEET NO.
372	2013-038B-R	COOK	821	487
CONTRACT NO. 60J16				

ILLINOIS FED. AID PROJECT