

NEAR PIER

NEAR MIDSPAN

**CROSS SECTION**

(Looking Upstation/North)  
(showing Floor Drains)

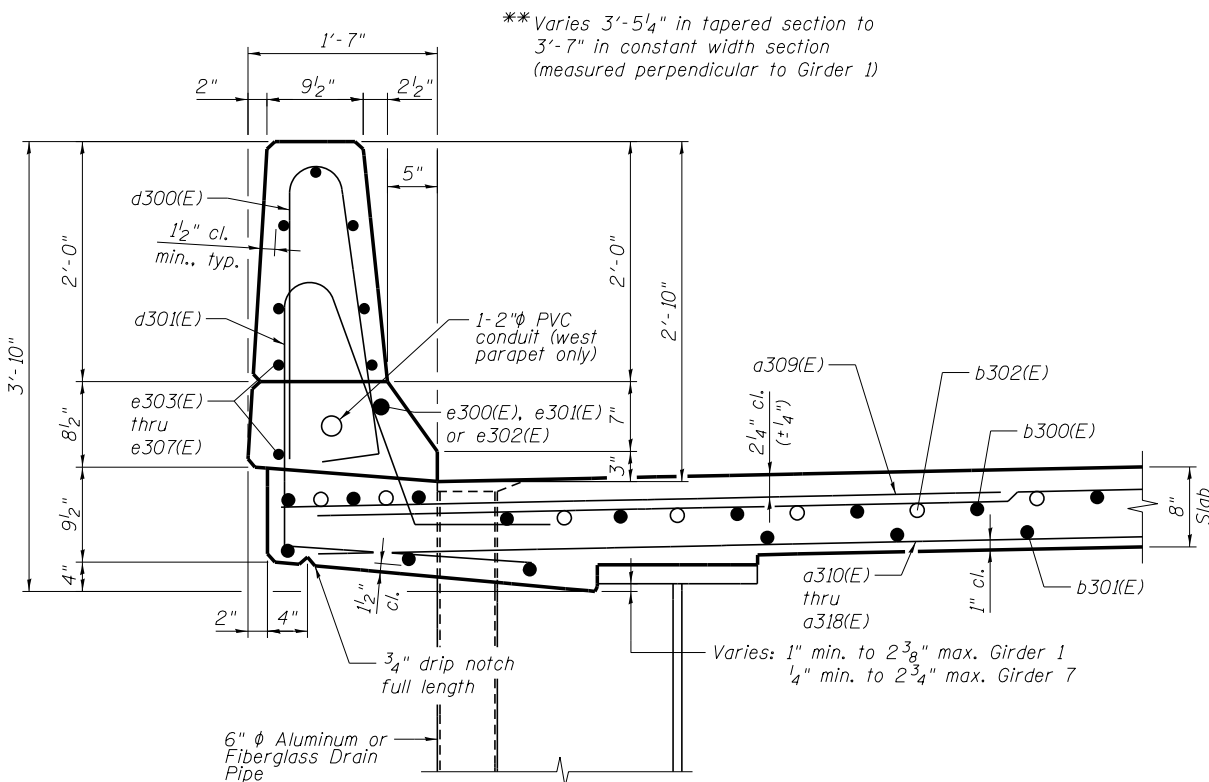

**SECTION THRU PARAPET**

(showing Floor Drain)

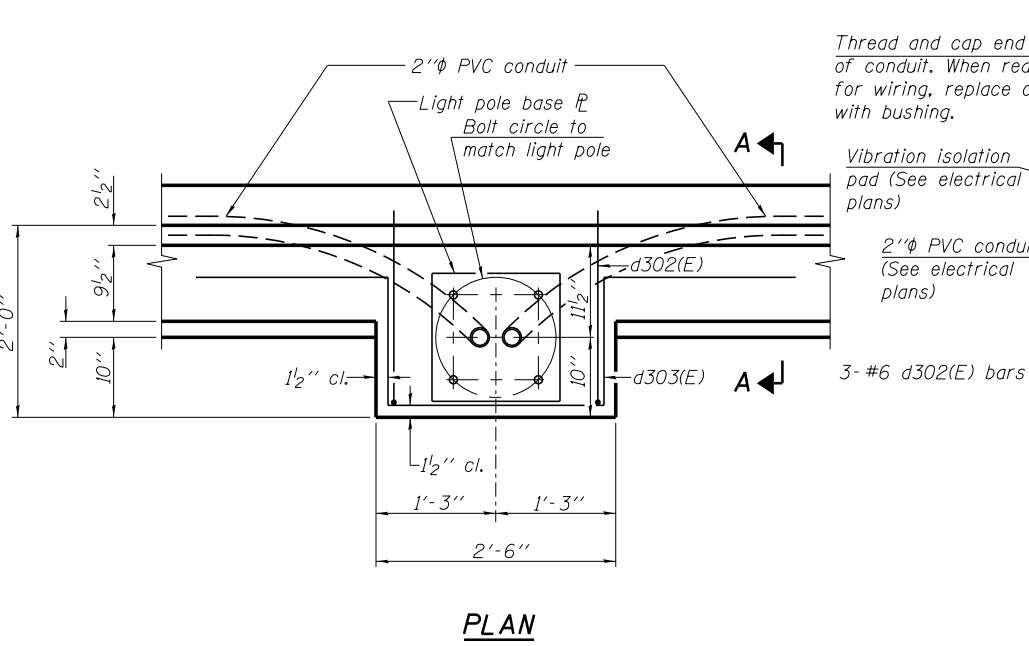

**PLAN**

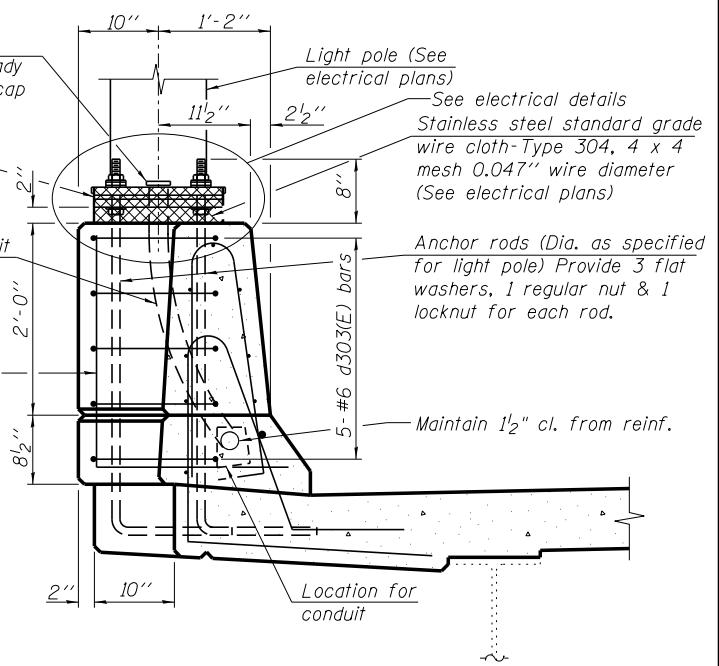

**SECTION A-A**

Note:  
Cost of anchor rods is included with Concrete Superstructure.

**benesch**  
engineers · scientists · planners  
Alfred Benesch & Company  
205 North Michigan Avenue, Suite 2400  
Chicago, Illinois 60601  
312-565-0450 Job No. 10093

FILE NAME =	USER NAME = jsurber	DESIGNED - JLS	REVISED -
0160483.60J16.013.Deck.Section.dgn		CHECKED - MFH	REVISED -
		DRAWN - KMS	REVISED -
		CHECKED - MFH	REVISED -

**STATE OF ILLINOIS**  
**DEPARTMENT OF TRANSPORTATION**

**DECK CROSS SECTION AND DETAILS**  
**STRUCTURE NO. 016-0483**

F.A.P. RTE.	SECTION	COUNTY	TOTAL SHEETS	SHEET NO.
372	2013-038B-R	COOK	821	497
CONTRACT NO. 60J16				

SHEET NO. SE13 OF SE46 SHEETS

ILLINOIS FED. AID PROJECT

Y:\chicago\100005\100093\Eng\_Docs\Phase 1\16.0483.0985\_1st\_Ave.cover\_Des\_Plaines\_River\Final\0160483.60J16.013.Deck.Section.dgn 5:23:44 PM 8/11/2014