

ELEVATION

TYPE A

6'-3" (1.905 M) TYPICAL POST SPACING

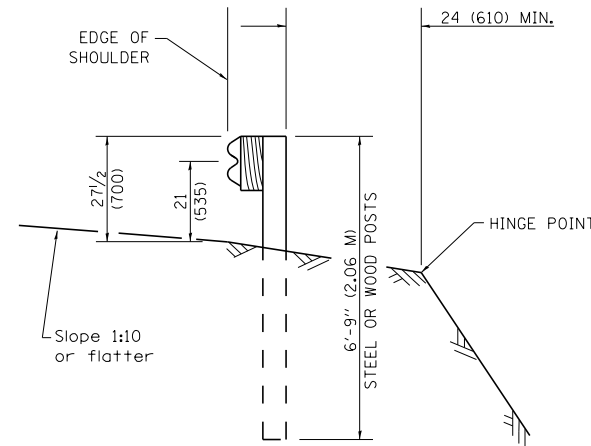

SECTION A-A

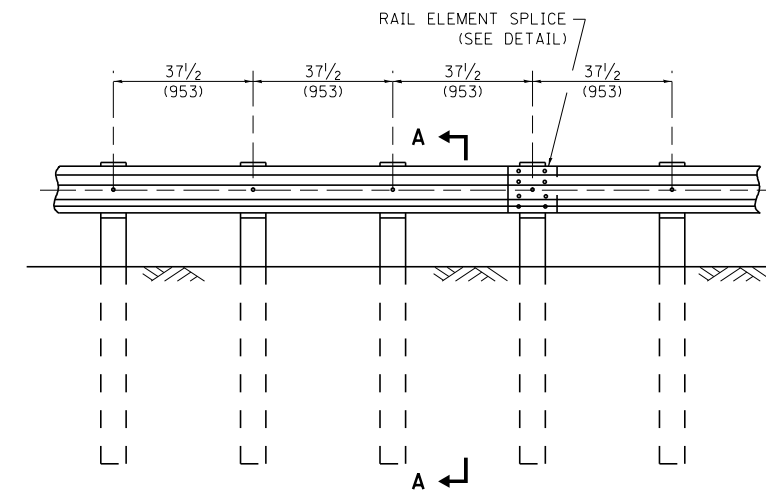

ELEVATION

TYPE A

37 1/2 (953) CLOSED POST SPACING

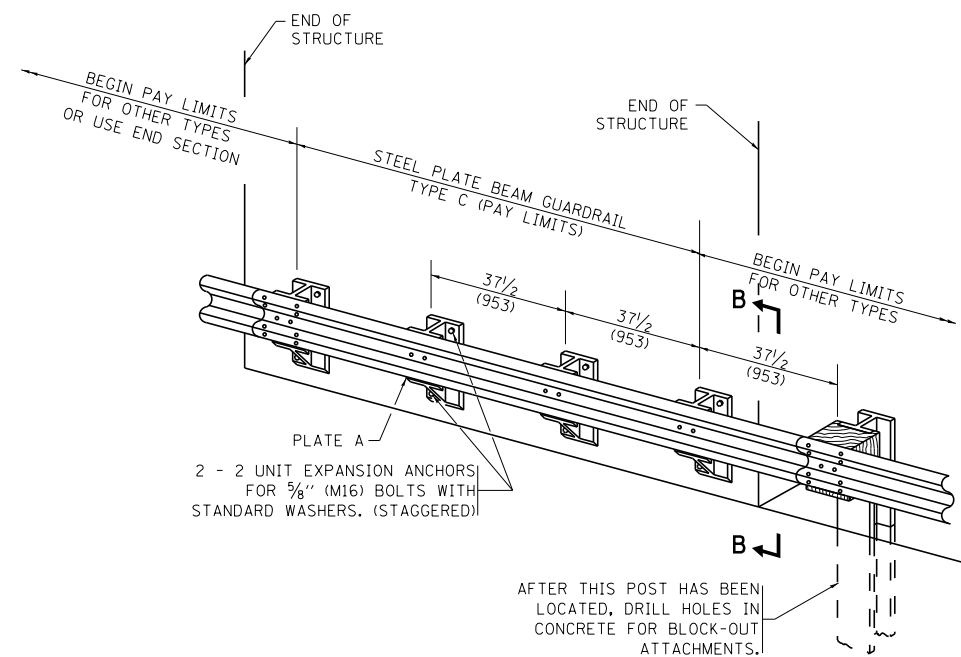

TYPE C

37 1/2 (953) BLOCK-OUT SPACING

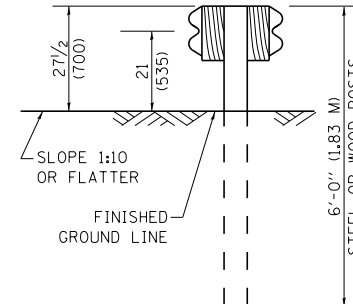

SECTION C-C

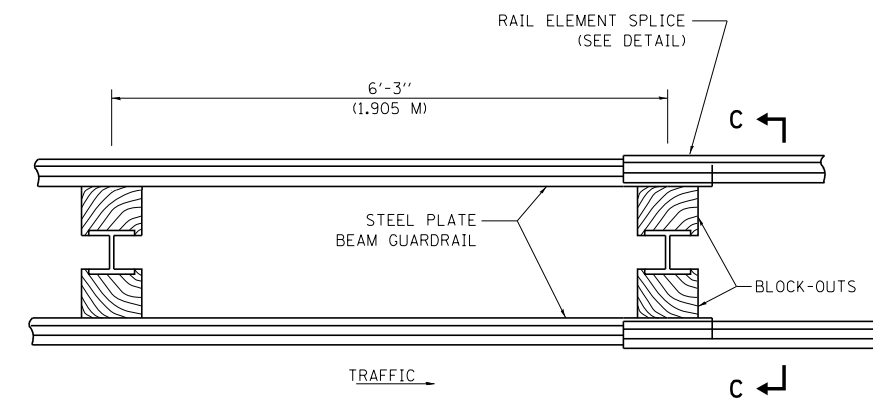

TRAFFIC

PLAN

TYPE D

DOUBLE STEEL PLATE BEAM GUARDRAIL
6'-3" (1.905 M) TYPICAL POST SPACING

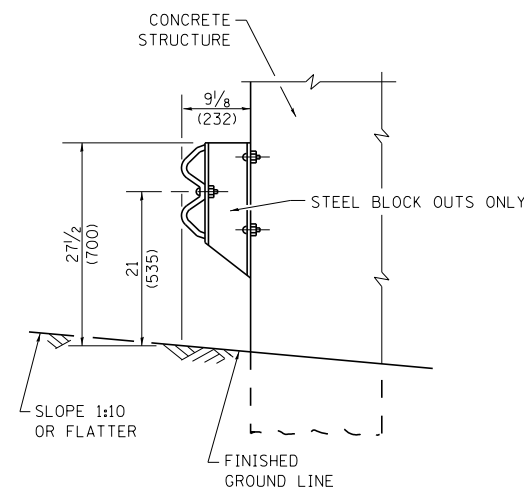

SECTION B-B

GENERAL NOTES

ALL SLOPE RATIOS ARE EXPRESSED AS UNITS OF VERTICAL DISPLACEMENT TO UNITS OF HORIZONTAL DISPLACEMENT (V:H).

ALL DIMENSIONS ARE IN INCHES (MILLIMETERS) UNLESS OTHERWISE SHOWN.

THE EXISTING STEEL POSTS MAY BE DRILLED TO MATCH THE BOLT PATTERN SHOWN HEREIN FOR THE WOOD BLOCK-OUT, OR A NEW STEEL POST SHALL BE PROVIDED.

THIS DETAIL IS APPLICABLE TO THE GUARDRAIL SYSTEM USED PRIOR TO JANUARY 1, 2007. FOR DETAILS ON THE MIDWEST GUARDRAIL SYSTEM, SEE STANDARD 630001.

FILE NAME = ...\\D160J16-sht-D1-bm-21a.dgn

USER NAME = tblank
PLOT SCALE =
PLOT DATE = 6/23/2014

DESIGNED -
DRAWN -
CHECKED -
DATE -

REVISED - 10-31-06
REVISED -
REVISED -
REVISED -

**STATE OF ILLINOIS
DEPARTMENT OF TRANSPORTATION**

**REMOVE AND REERECT
STEEL PLATE BEAM GUARDRAIL**

SCALE: NONE SHEET NO. 1 OF 4 SHEETS STA. TO STA.

F.A.P. RTE.	SECTION	COUNTY	TOTAL SHEETS	SHEET NO.
	2013-038B-R	COOK	821	796
BM-21			CONTRACT NO. 60J16	
FED. ROAD DIST. NO. 1 ILLINOIS FED. AID PROJECT				