

LEGEND

- ① EXIST. AGGREGATE SHOULDER
- ② EXIST. CURB AND GUTTER
- ③ EXIST. BITUMINOUS OVERLAY (±) 7"
- ④ EXIST. HMA PAVEMENT AFTER MILLING, ± 4 1/2" MIN.
- ⑤ EXIST. PCC BASE COURSE ± 9"-7"-9"
- ⑥ PROP. HMA SURFACE REMOVAL, 2 1/2 "
- ⑦ PROP. POLYMERIZED HOT-MIX ASPHALT SURFACE COURSE, MIX "F", N90, 1 3/4 "
- ⑧ PROP. POLYMERIZED LEVELING BINDER (MM), IL-4.75, N50, 3/4 "
- ⑨ PROP. AGGREGATE WEDGE SHOULDER, TYPE B
- ⑩ PROP. SHAPING AND GRADING SHOULDERS

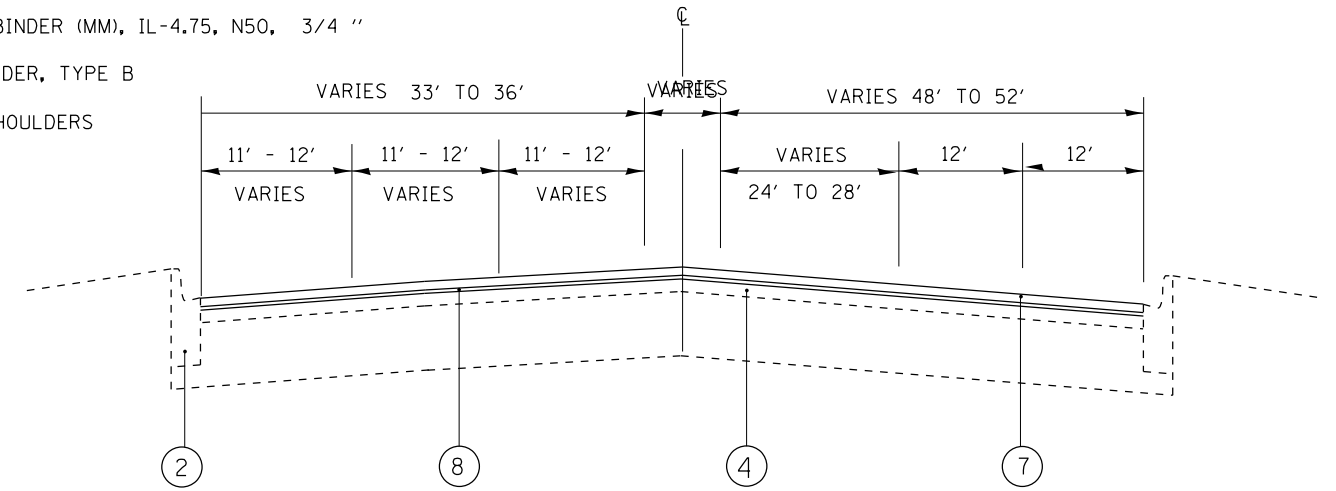
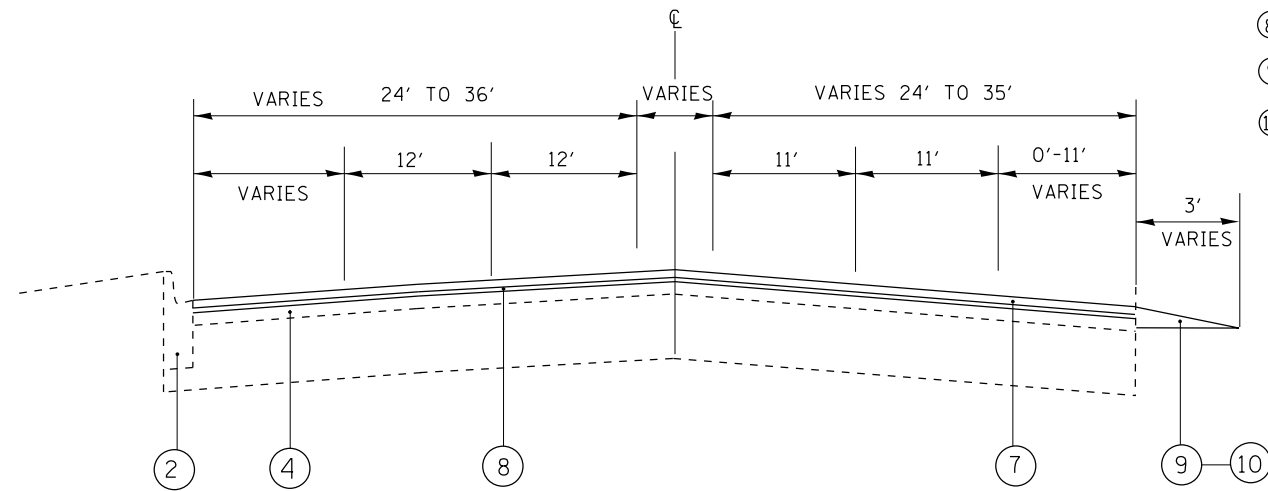

NOTE:
CONTRACTOR SHALL MILL FIRST BEFORE PATCHING

FILE NAME =	USER NAME = hardnetbr	DESIGNED -	REVISED -	STATE OF ILLINOIS DEPARTMENT OF TRANSPORTATION	EXISTING AND PROPOSED TYPICAL SECTIONS IL. RTE. 21 / U.S. RTE. 45 (MILWAUKEE RD.)	F.A.P. RTE.	SECTION	COUNTY	TOTAL SHEETS	SHEET NO.	
Default	51012-sh1-plen.dgn	DRAWN -	REVISED -			330	(1&1)RS-3	LAKE	60	7	
	PLOT SCALE = 100.0000' / in.	CHECKED -	REVISED -			CONTRACT NO. 60V03					
	PLOT DATE = 7/18/2014	DATE -	REVISED -			ILLINOIS FED. AID PROJECT					