

**PLAN**

The pay items for Preformed Joint Strip Seal shall be to the end of the steel plate. The 6" of rubber extending past the end of the steel shall be considered incidental and shall not be measured for payment.

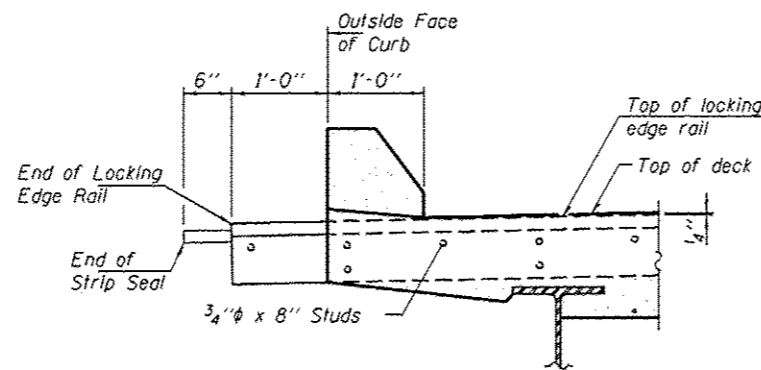

**SECTION A-A**

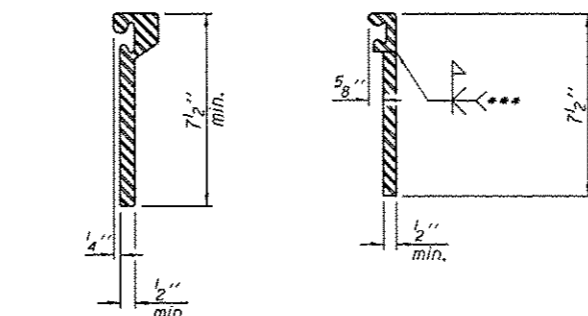

**ROLLED EXTRUDED RAIL**      **WELDED RAIL**

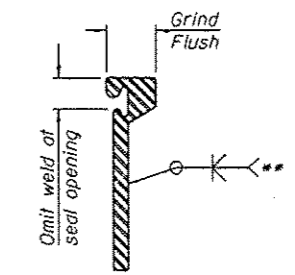

\*\* Back gouge not required if complete joint penetration is verified by mock-up.

**LOCKING EDGE RAIL SPLICE**

The inside of the locking edge rail groove shall be free of weld residue.  
Rolled rail shown, welded rail similar.

**LOCKING EDGE RAILS**

**Notes:**  
The strip seal shall be made continuous and shall have a minimum thickness of 1/4". The configuration of the strip seal shall match the configuration of the Locking Edge Rails. Open or "webbed" strip seal gland configurations are not permitted. The gland shall be sized for a maximum rated movement of 4 inches.  
The Locking Edge Rails depicted are conceptual only, except for the minimum dimensions shown. The actual configuration of the Locking Edge Rails and matching strip seal may vary from manufacturer to manufacturer. Flanged edge rails will not be allowed. Locking Edge Rails may be spliced at slope discontinuities.  
The manufacturer's recommended installation methods shall be followed.  
The joint opening and deck dimensions detailed on the superstructure are based on a rolled rail expansion joint. If the Contractor elects to use the welded rail expansion joint, the opening and deck dimensions shall be modified according to the dimensions detailed on this sheet. Required modifications shall be made at no additional cost to the State.  
All steel components shall be galvanized after fabrication according to Article 520.03 of the Standard Specifications. Maximum space between rail segments shall be 3/16", sealed with a suitable sealant. Joints in rails within 10 ft. of curbs shall be welded.  
Parapet plates and anchorage studs for skew > 30° included in the cost of Preformed Joint Strip Seal.

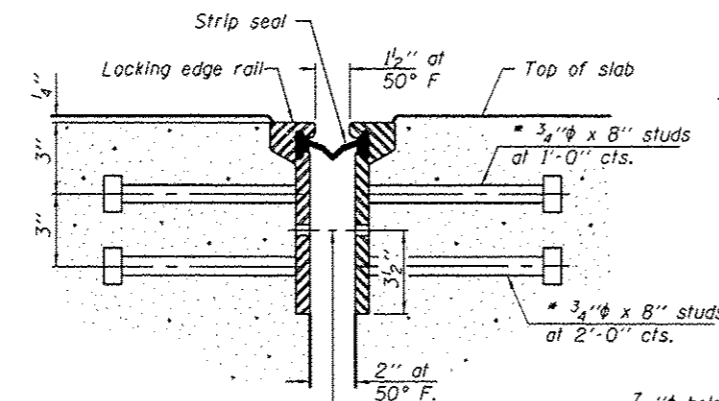

**SECTION THRU ROLLED RAIL JOINT**

7/16" diameter holes at 4'-0" cts. for 3/8" diameter bolts. All bolts shall be burned, sawed, or chipped off flush with the plates after forms are removed, typ.

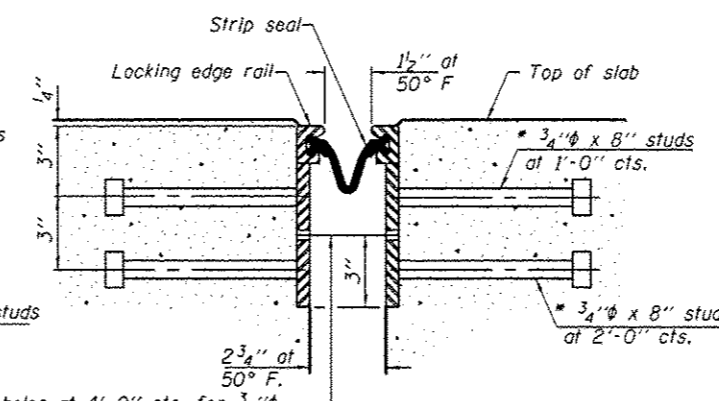

**SECTION THRU WELDED RAIL JOINT**

7/16" diameter holes at 4'-0" cts. for 3/8" diameter bolts. All bolts shall be burned, sawed, or chipped off flush with the plates after forms are removed, typ.

\* Granular or solid flux filled headed studs conforming to Article 1006.32 of the Std. Specs., automatically end welded.

**BILL OF MATERIAL**

Item	Unit	Total
Preformed Joint Strip Seal	Foot	33