

D-97-034-05 \*34+1=35

STATE OF ILLINOIS  
DEPARTMENT OF TRANSPORTATION  
DIVISION OF HIGHWAYS

**PROPOSED  
HIGHWAY PLANS**

FAP RTE 781 (IL 33)  
SECTION 109B-1

LAWRENCE COUNTY

C - 97 - 069 - 05

STRUCTURE REPLACEMENT  
OVER UNNAMED STREAM

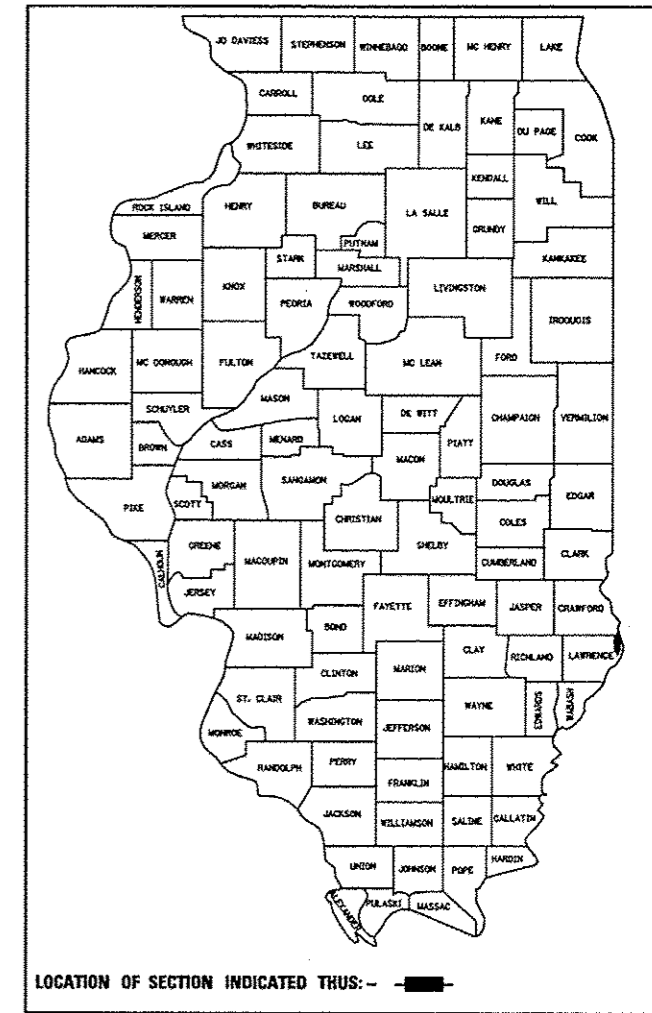

FUNCTIONAL CLASSIFICATION: RURAL MINOR ARTERIAL  
 DESIGN SPEED: 55 mph  
 POSTED SPEED: 55 mph  
 ADT: 859(2011)  
 PV: 88.7%  
 SU: 5.0%  
 MU: 6.3%

STATE OF ILLINOIS  
DEPARTMENT OF TRANSPORTATION  
DIVISION OF HIGHWAYS

SUBMITTED July 2 2014  
*Roger L. Drishell*  
 DEPUTY DIRECTOR OF HIGHWAYS, REGION ENGINEER

June 27 2014  
*John D. Baranzelli*  
 acting ENGINEER OF DESIGN AND ENVIRONMENT

June 27 2014  
*Omer Osman*  
 DIRECTOR OF HIGHWAYS, CHIEF ENGINEER

INDEX OF SHEETS

- | SHEET NO.                       | DESCRIPTION                                       |
|---------------------------------|---|
| <b>ROADWAY PLANS</b>            |   |
| 1.                              | COVER SHEET                                       |
| 2.                              | GENERAL NOTES                                     |
| 3.                              | STANDARDS   |
| 4.                              | SUMMARY OF QUANTITIES                             |
| 5.                              | TYPICAL SECTIONS                                  |
| 6.                              | SCHEDULES OF QUANTITIES                           |
| 7.-9.                           | FAP RTE 781 (IL 33) PLAN AND PROFILE              |
| 10.-11.                         | STAGE CONSTRUCTION PLANS                          |
| 12.                             | STAGE CONSTRUCTION DETAILS                        |
| 13.                             | EROSION CONTROL AND DRAINAGE PLAN                 |
| 14.                             | MISCELLANEOUS DETAILS                             |
| <b>STRUCTURE PLANS</b>          |   |
| 15.                             | GENERAL PLAN                                      |
| 16.                             | GENERAL DATA                                      |
| 17.-18.                         | STAGE CONSTRUCTION DETAILS                        |
| 19.-20.                         | BOX CULVERT DETAILS                               |
| 21.                             | STEEL SHEET PILING WALL DETAILS                   |
| 22.                             | BAR SPLICER ASSEMBLY DETAILS                      |
| 23.                             | TEMPORARY CONCRETE BARRIER FOR STAGE CONSTRUCTION |
| 24.                             | BORING LOGS                                       |
| <b>EXISTING STRUCTURE PLANS</b> |   |
| 25.-28.                         | EXISTING STRUCTURE PLANS                          |
| <b>CROSS SECTIONS</b>           |   |
| 29.-34.                         | FAP 781 (IL 33) CROSS SECTIONS                    |

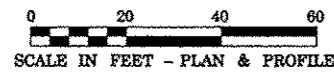

FULL SIZE PLANS HAVE BEEN PREPARED USING STANDARD ENGINEERING SCALES. REDUCED SIZED PLANS WILL NOT CONFORM TO STANDARD SCALES. IN MAKING MEASUREMENTS ON REDUCED PLANS, THE ABOVE SCALES MAY BE USED.

MICROFILMED \_\_\_\_\_  
 REEL NUMBER \_\_\_\_\_  
 AWARDED \_\_\_\_\_  
 RESIDENT ENGINEER \_\_\_\_\_  
 AS BUILT CHANGES WERE MADE ON THE FOLLOWING SHEETS \_\_\_\_\_

J.U.L.I.E.  
 JOINT UTILITY LOCATION INFORMATION FOR EXCAVATION  
 1-800-892-0123  
 OR 811

DISTRICT 7 NO. (217) 342-3951  
 PROJECT ENGINEER: TOM RONAN  
 UNIT CHIEF:  
 TOWNSHIP: RUSSELL  
 CONTRACT NO.: 74105

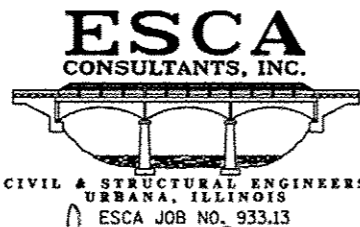

*Richard D. Payne*  
 RICHARD D. PAYNE  
 37421  
 LICENSED PROFESSIONAL ENGINEER  
 STATE OF ILLINOIS  
 ILLINOIS PROFESSIONAL LICENSE NO. 37421  
 (EXPIRATION DATE: 11-30-11)  
 DATE: 06/30/11

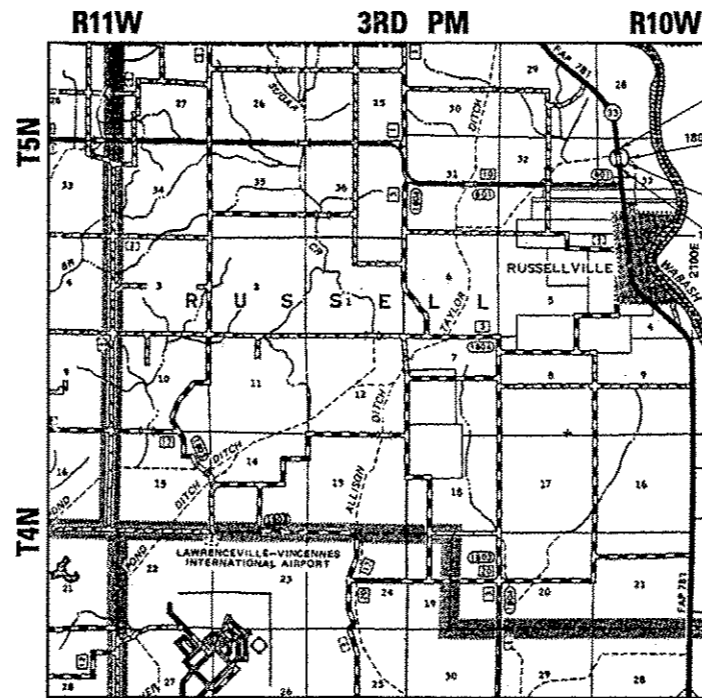

LOCATION MAP

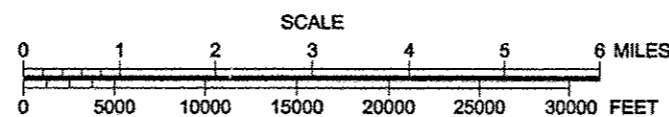

GROSS LENGTH = 720.5 FT. = 0.136 MI.  
 NET LENGTH = 720.5 FT. = 0.136 MI.

DESIGN DESIGNATION  
**N.A.**

PRINTED BY THE AUTHORITY  
 OF THE STATE OF ILLINOIS

**INDEX OF SHEETS**

SHEET NO.	ITEM
1	COVER SHEET
2	INDEX OF SHEETS, GENERAL NOTES, & HIGHWAY STANDARDS
3-4A	SUMMARY OF QUANTITIES
5	TYPICAL SECTIONS
6	SCHEDULES OF QUANTITIES
7-9	PLAN & PROFILE SHEETS
10-12	STAGE CONSTRUCTION DETAILS
13	EROSION CONTROL & DRAINAGE PLAN
14	MISCELLANEOUS DETAILS
15-20	STRUCTURE PLAN SHEETS & DETAILS
21	SHEET PILING WALL DETAILS
22	BAR SPLICER ASSEMBLY DETAILS
23	TEMPORARY CONCRETE BARRIER DETAILS
24	SOIL BORING LOGS
25-28	EXISTING STRUCTURE PLANS
29-34	CROSS SECTIONS

THE FOLLOWING STANDARDS ARE A PART OF THESE PLANS AND ARE INCLUDED AFTER SHEET NO. 34:

STD. NO.	DESCRIPTION
000001-06	STANDARD SYMBOLS, ABBREVIATIONS AND PATTERNS
001001-02	AREAS OF REINFORCEMENT BARS
001006	DECIMAL OF AN INCH AND OF A FOOT
280001-07	TEMPORARY EROSION CONTROL SYSTEMS
515001-03	NAME PLATE FOR BRIDGES
630001-10	STEEL PLATE BEAM GUARDRAIL
630201-06	PCC/HMA STABILIZATION AT STEEL PLATE BEAM GUARDRAIL
630301-06	SHOULDER WIDENING FOR TYPE I (SPECIAL) GUARDRAIL TERMINALS
635001-01	DELINEATORS
635006-03	REFLECTOR AND TERMINAL MARKER PLACEMENT
635011-02	REFLECTOR MARKER AND MOUNTING DETAILS
701001-02	OFF-ROAD OPERATIONS, 2L2W, 15' MINIMUM AWAY FROM PAVEMENT EDGE
701006-05	OFF-ROAD OPERATIONS, 2L2W, 15' AWAY TO EDGE OF PAVEMENT
701011-04	OFF-ROAD MOVING OPERATIONS, 2L2W, DAY ONLY
701201-04	LANE CLOSURE, 2L2W, DAY ONLY
701301-04	LANE CLOSURE, 2L2W, SHORT TIME OPERATIONS
701311-03	LANE CLOSURE, 2L2W, MOVING OPERATIONS - DAY ONLY
701321-13	LANE CLOSURE, 2L2W, BRIDGE REPAIR WITH BARRIER
701326-04	LANE CLOSURE, 2L2W, PAVEMENT WIDENING
701901-03	TRAFFIC CONTROL DEVICES
704001-07	TEMPORARY CONCRETE BARRIER
720001-01	SIGN PANEL MOUNTING DETAILS
720006-04	SIGN PANEL ERECTION DETAILS
720011-01	METAL POSTS FOR SIGNS, MARKERS, & DELINEATORS
729001-01	APPLICATIONS OF TYPES A & B METAL POSTS (FOR SIGNS & MARKERS)
780001-04	TYPICAL PAVEMENT MARKINGS
781001-03	TYPICAL APPLICATIONS RAISED REFLECTIVE PAVEMENT MARKERS
442201-03	CLASS C AND D PATCHES

**GENERAL NOTES**

THIS SECTION SHALL BE CONSTRUCTED IN ACCORDANCE WITH THE PLANS; THE "STANDARD SPECIFICATIONS FOR ROAD AND BRIDGE CONSTRUCTION" ADOPTED JANUARY 1, 2012; AND THE SPECIAL PROVISIONS INCLUDED IN THE PROPOSAL.

THIS PROJECT IS LOCATED ON FAP 781 (ILLINOIS ROUTE 33) AT STRUCTURE NUMBER 051-0035. STRUCTURE NUMBER 051-0035 IS LOCATED 1.5 MILES SOUTH OF THE CRAWFORD COUNTY LINE IN LAWRENCE COUNTY. THE WORK INCLUDED IN SECTION 109B-1 CONSISTS OF BASE COURSE WIDENING, STRUCTURE REMOVAL, BOX CULVERT CONSTRUCTION, EARTHWORK, PAVEMENT MARKING, TRAFFIC CONTROL, AND ANY OTHER WORK NECESSARY TO COMPLETE THE SECTION.

PLAN DIMENSIONS AND DETAILS RELATIVE TO THE EXISTING STRUCTURE HAVE BEEN TAKEN FROM EXISTING PLANS AND ARE SUBJECT TO NOMINAL CONSTRUCTION VARIATIONS. IT SHALL BE THE CONTRACTORS RESPONSIBILITY TO VERIFY DIMENSIONS AND DETAILS IN THE FIELD AND MAKE NECESSARY APPROVED ADJUSTMENTS PRIOR TO CONSTRUCTION OR ORDERING OF MATERIAL. SUCH VARIATIONS SHALL NOT BE CAUSE FOR ADDITIONAL COMPENSATION FOR A CHANGE IN THE SCOPE OF THE WORK. THE CONTRACTOR WILL BE PAID FOR THE QUANTITY FURNISHED AT THE UNIT PRICE BID FOR THE WORK.

THE LOCATIONS AND/OR DEPTHS OF UNDERGROUND UTILITIES SHOWN HAVE BEEN TAKEN FROM INFORMATION FURNISHED BY THE UTILITY OWNERS AND MUST BE CONSIDERED APPROXIMATE. FIELD MARKINGS OF UTILITIES IN CRITICAL AREAS MAY BE OBTAINED BY PROVIDING A MINIMUM OF 96 HOURS ADVANCE NOTICE THROUGH THE J.U.L.I.E. SYSTEM BY CALLING 800-892-0123.

ANY EXCAVATION NECESSARY FOR CONSTRUCTION OF THE PCC BASE COURSE WIDENING, 8" SHALL BE INCLUDED IN THE COST OF THE PCC BASE COURSE WIDENING, 8" AND NO ADDITIONAL COMPENSATION WILL BE ALLOWED. PCC BASE COURSE WIDENING EXCEEDING 6' IN WIDTH SHALL BE PAID FOR AS PCC BASE COURSE WIDENING OF THE THICKNESS SPECIFIED.

PCC BASE COURSE WIDENING SHALL BE MILLED TO THE SAME DEPTH AS THE ADJACENT ROADWAY TO FACILITATE CONSTRUCTION OF HMA SHOULDERS. THIS WORK WILL BE PAID FOR AS PORTLAND CEMENT CONCRETE SURFACE REMOVAL (VARIABLE DEPTH). MILLING BUTT JOINTS WILL NOT BE PAID FOR SEPARATELY BUT SHALL BE INCLUDED IN THE CONTRACT UNIT PRICE FOR HOT-MIX ASPHALT SURFACE REMOVAL, VARIABLE DEPTH.

THE CONTRACTOR SHALL PROVIDE INTERNET ACCESSIBILITY TO THE HMA PLANT QUALITY CONTROL LAB SO THAT HMA PLANT REPORTS CAN BE E-MAILED TO THE DISTRICT OFFICE. THIS REQUIREMENT SHALL BE INCLUDED IN THE COST OF ALL HOT-MIX ASPHALT ITEMS.

REMOVAL OF TEMPORARY CONCRETE BARRIER FROM THE PROJECT SITE SHALL BE CONSIDERED INCLUDED IN THE TEMPORARY CONCRETE BARRIER PAY ITEMS AND NO ADDITIONAL COMPENSATION WILL BE ALLOWED FOR REMOVING THE TEMPORARY CONCRETE BARRIER.

THE PAY ITEM TEMPORARY RAMP HAS BEEN INCLUDED FOR THE CONSTRUCTION OF TEMPORARY RAMPS IN ACCORDANCE WITH ARTICLE 406.08 OF THE STANDARD SPECIFICATIONS. THE COST PER SQUARE YARD SHALL INCLUDE BOTH THE INSTALLATION AND THE REMOVAL OF THE TEMPORARY RAMPS.

THE ENGINEER SHALL BE THE SOLE JUDGE REGARDING THE CURING TIMES FOR ALL HOT-MIX ASPHALT.

EXISTING TRAFFIC BARRIER TERMINALS TO BE REMOVED SHALL BE PAID FOR AS GUARDRAIL REMOVAL.

ALL ELEVATIONS REFER TO U.S.G.S. MEAN SEA LEVEL DATUM.

THE CONTRACTOR WILL BE REQUIRED TO MODIFY THE EXISTING CHANNEL, AS DIRECTED BY THE ENGINEER, TO MATCH BOTH ENDS OF THE PROPOSED BOX CULVERT. THE COST SHALL BE INCLUDED IN THE PAY ITEM FOR STONE RIPRAP, CLASS A4.

**GENERAL NOTES (Cont'd)**

SHORT-TERM PAVEMENT MARKING ON MILLED SURFACES SHALL BE PAINT. SHORT-TERM PAVEMENT MARKING ON THE HMA SURFACE COURSE SHALL BE TAPE.

PAVEMENT MARKING SHALL BE APPLIED IN ACCORDANCE WITH SECTION 780 OF THE STANDARD SPECIFICATIONS.

THE TOTAL QUANTITY OF PAINT PAVEMENT MARKING-LINE 4" CONSISTS OF 909 FEET OF WHITE AND 200 FEET OF YELLOW.

ALL RAISED REFLECTIVE PAVEMENT MARKERS ARE TWO-WAY AMBER MARKERS.

LENSES ON THE RAISED REFLECTIVE PAVEMENT MARKERS IN THE TAPER AREAS SHALL BE REMOVED. REMOVING, STORING, AND REINSTALLATION OF THE LENSES SHALL BE INCLUDED IN THE COST OF TRAFFIC CONTROL AND PROTECTION STANDARD 701321.

THE FOLLOWING MIXTURE REQUIREMENTS ARE APPLICABLE TO THIS PROJECT:

MIXTURE USE:	SURFACE COURSE (1 1/2")
APPLICATION:	HOT MIX ASPHALT SURFACE COURSE, MIX "C", N70
PG GRADE:	PG 64-22
DESIGN AIR VOIDS:	4.0% @ NDESIGN = 70
MIXTURE COMPOSITION:	IL-9.5
FRICTION AGGREGATE:	MIXTURE C

MIXTURE USE:	HMA BASE COURSE (10")
APPLICATION:	HOT MIX ASPHALT BASE COURSE
PG GRADE:	PG 64-22
DESIGN AIR VOIDS:	4.0% @ NDESIGN = 70
MIXTURE COMPOSITION:	IL-19.0
FRICTION AGGREGATE:	N/A

MIXTURE USE:	HMA SHOULDERS
APPLICATION:	HOT MIX ASPHALT SHOULDERS
PG GRADE:	PG 64-22
DESIGN AIR VOIDS:	4.0% @ NDESIGN = 30
MIXTURE COMPOSITION:	IL-19.0L
FRICTION AGGREGATE:	N/A

THE FOLLOWING RATES OF APPLICATION HAVE BEEN USED IN THE CALCULATING PLAN QUANTITIES:

AGGREGATE MATERIALS	2.05 TONS/CU YD
BITUMINOUS MATERIALS (PRIME COAT)	0.05 LBS/SQ FT
HOT-MIX ASPHALT	112 LBS/SQ YD/INCH

**HMA MIXTURES REQUIREMENTS**

MIXTURE USE:	SURFACE COURSE	BASE COURSE, 10"	HOT-MIX ASPHALT SHOULDERS
APPLICATION:	HOT-MIX ASPHALT SURFACE COURSE, MIX "C", N70	HOT-MIX ASPHALT BASE COURSE	HOT-MIX ASPHALT SHOULDERS
PG GRADE:	PG64-22	PG64-22	PG64-22
DESIGN AIR VOIDS:	4.0% AT NDESIGN = 70	4.0% AT NDESIGN = 70	4.0% AT NDESIGN = 30
MIXTURE COMPOSITION:	IL-9.5	IL-19.0	IL-19.0L
FRICTION AGGREGATE:	MIXTURE C	NA	NA

100% STATE

100% STATE

SUMMARY OF QUANTITIES			CONSTRUCTION TYPE CODE		
CODE NO	ITEM	UNIT	TOTAL QUANTITIES	0011	
				SN 051-2008	
20200100	EARTH EXCAVATION	CU YD	640	640	
20300100	CHANNEL EXCAVATION	CU YD	510	510	
20400800	FURNISHED EXCAVATION	CU YD	280	280	
20700220	POROUS GRANULAR EMBANKMENT	CU YD	640	640	
21101505	TOPSOIL EXCAVATION AND PLACEMENT	CU YD	185	185	
25000350	SEEDING, CLASS 7	ACRE	0.4	0.4	
28000250	TEMPORARY EROSION CONTROL SEEDING	POUND	80	80	
28000400	PERIMETER EROSION BARRIER	FOOT	1135	1135	
28100107	STONE RIPRAP, CLASS A4	SQ YD	257	257	
28200200	FILTER FABRIC	SQ YD	257	257	
31101200	SUBBASE GRANULAR MATERIAL, TYPE B 4"	SQ YD	301	301	
35400300	PORTLAND CEMENT CONCRETE BASE COURSE WIDENING 8"	SQ YD	739	739	
35501324	HOT-MIX ASPHALT BASE COURSE, 10"	SQ YD	250	250	

SUMMARY OF QUANTITIES			CONSTRUCTION TYPE CODE		
CODE NO	ITEM	UNIT	TOTAL QUANTITIES	0011	
				SN 051-2008	
40200800	AGGREGATE SURFACE COURSE, TYPE B	TON	20	20	
40600990	TEMPORARY RAMP	SQ YD	25	25	
40603315	HOT-MIX ASPHALT SURFACE COURSE, MIX "C", N70	TON	105	105	
44000100	PAVEMENT REMOVAL	SQ YD	449	449	
44201815	CLASS D PATCHES, TYPE II, 14 INCH	SQ YD	12	12	
48203100	HOT-MIX ASPHALT SHOULDERS	TON	305	305	
50100100	REMOVAL OF EXISTING STRUCTURES	EACH	1	1	
50200450	REMOVAL AND DISPOSAL OF UNSUITABLE MATERIAL FOR STRUCTURES	CU YD	515	515	
50800105	REINFORCEMENT BARS	POUND	62780	62780	
50800515	BAR SPLICERS	EACH	188	188	
51500100	NAME PLATES	EACH	1	1	
54003000	CONCRETE BOX CULVERTS	CU YD	284	284	

100% STATE

100% STATE

SUMMARY OF QUANTITIES			CONSTRUCTION TYPE CODE			
CODE NO	ITEM	UNIT	TOTAL QUANTITIES	0011		
				SN 051-2008		
* 63000001	STEEL PLATE BEAM GUARD RAIL, TYPE A, 6 FOOT POSTS	FOOT	612.5	612.5		
* 63100167	TRAFFIC BARRIER TERMINAL, TYPE 1 (SPECIAL) TANGENT	EACH	8	8		
63200310	GUARDRAIL REMOVAL	FOOT	287	287		
67000400	ENGINEER'S FIELD OFFICE, TYPE A	CAL MO	5	5		
67100100	MOBILIZATION	L SUM	1	1		
70100405	TRAFFIC CONTROL AND PROTECTION, STANDARD 701321	EACH	1	1		
70100450	TRAFFIC CONTROL AND PROTECTION, STANDARD 701201	L SUM	1	1		
70100500	TRAFFIC CONTROL AND PROTECTION, STANDARD 701326	L SUM	1	1		
70103815	TRAFFIC CONTROL SURVEILLANCE	CAL DA	6	6		
70106500	TEMPORARY BRIDGE TRAFFIC SIGNALS	EACH	1	1		
70106700	TEMPORARY RUMBLE STRIP	EACH	6	6		

SUMMARY OF QUANTITIES			CONSTRUCTION TYPE CODE			
CODE NO	ITEM	UNIT	TOTAL QUANTITIES	0011		
				SN 051-2008		
70300100	SHORT-TERM PAVEMENT MARKING	FOOT	160	160		
70300220	TEMPORARY PAVEMENT MARKING LINE 4"	FOOT	1109	1109		
70301000	WORK ZONE PAVEMENT MARKING REMOVAL	SQ FT	424	424		
70400100	TEMPORARY CONCRETE BARRIER	FOOT	900	900		
70400200	RELOCATE TEMPORARY CONCRETE BARRIER	FOOT	187.5	187.5		
70600250	IMPACT ATTENUATORS, TEMPORARY (NON-REDIRECTIVE), TEST LEVEL 3	EACH	2	2		
70600260	IMPACT ATTENUATORS, TEMPORARY (FULLY REDIRECTIVE, NARROW), TEST LEVEL 3	EACH	2	2		
70600350	IMPACT ATTENUATORS, RELOCATE (NON-REDIRECTIVE), TEST LEVEL 3	EACH	2	2		
* 78001110	PAINT PAVEMENT MARKING - LINE 4"	FOOT	1109	1109		
* 78100100	RAISED REFLECTIVE PAVEMENT MARKER	EACH	5	5		
* 78200410	GUARDRAIL MARKERS, TYPE A	EACH	11	11		
* 78201000	TERMINAL MARKER - DIRECT APPLIED	EACH	8	8		

\* SPECIALTY ITEM

FILE NAME =	USER NAME = staffennk	DESIGNED -	REVISED -	<b>STATE OF ILLINOIS DEPARTMENT OF TRANSPORTATION</b>	<b>SUMMARY OF QUANTITIES</b>			F.A.P. RTE.	SECTION	COUNTY	TOTAL SHEETS	SHEET NO.
c:\pr-work\p\idoc\staffennk\20121448\07	4125-ahh-soq.dgn	DRAWN -	REVISED -					781	1098-1	LAWRENCE	34	4
	PLOT SCALE = 1/8" = 100.0000 ' / in.	CHECKED -	REVISED -		SCALE: N/A			SHEET 2 OF 3 SHEETS			STA. TO STA.	ILLINOIS FED. AID PROJECT
Default	PLOT DATE = 6/3/2014	DATE -	REVISED -		CONTRACT NO. 74105							

SUMMARY OF QUANTITIES			100% STATE		CONSTRUCTION TYPE CODE		
CODE NO	ITEM	UNIT	TOTAL QUANTITIES	0011 SN 051-2008			
78300100	PAVEMENT MARKING REMOVAL	SO FT	304	304			
X0426200	DEWATERING	L SUM	1	1			
X2501000	SEEDING, CLASS 2 (SPECIAL)	ACRE	0.4	0.4			
X4060110	BITUMINOUS MATERIALS (PRIME COAT)	POUND	330	330			
X4400100	PORTLAND CEMENT CONCRETE SURFACE REMOVAL (VARIABLE DEPTH)	SO YD	404	404			
X4401198	HOT-MIX ASPHALT SURFACE REMOVAL, VARIABLE DEPTH	SO YD	980	980			
X5121800	PERMANENT STEEL SHEET PILING	SO FT	402	402			
X7015005	CHANGEABLE MESSAGE SIGN	CAL DA	28	28			
Z0005010	HOT-MIX ASPHALT FOR PATCHING POTHOLES (COLD MIX)	TON	4	4			
Z0028462	GEOTEXTILE RETAINING WALL	SO FT	148	148			
* Z0054505	ROCK FILL - REPLACEMENT	TON	875	875			
Z0073002	TEMPORARY SOIL RETENTION SYSTEM	SO FT	362	362			

SUMMARY OF QUANTITIES			100% STATE		CONSTRUCTION TYPE CODE		
CODE NO	ITEM	UNIT	TOTAL QUANTITIES	0011 SN 051-2008			

\* SPECIALTY ITEM

FILE NAME =	USER NAME = staffferok	DESIGNED -	REVISED -
er:\pwork\pripdoc\staffferok\8121448\07	*185-ent-rs.dgn	DRAWN -	REVISED -
	PLOT SCALE = 1/8" = 1'-0"	CHECKED -	REVISED -
Default	PLOT DATE = 6/3/2014	DATE -	REVISED -

STATE OF ILLINOIS  
DEPARTMENT OF TRANSPORTATION

SUMMARY OF QUANTITIES

F.A.P. RTE. =	SECTION	COUNTY	TOTAL SHEETS	SHEET NO.
781	1098-1	LAWRENCE	34	4A
SCALE: N/A				CONTRACT NO. 74105
SHEET 3 OF 3 SHEETS		STA. TO STA.	ILLINOIS FED. AID PROJECT	

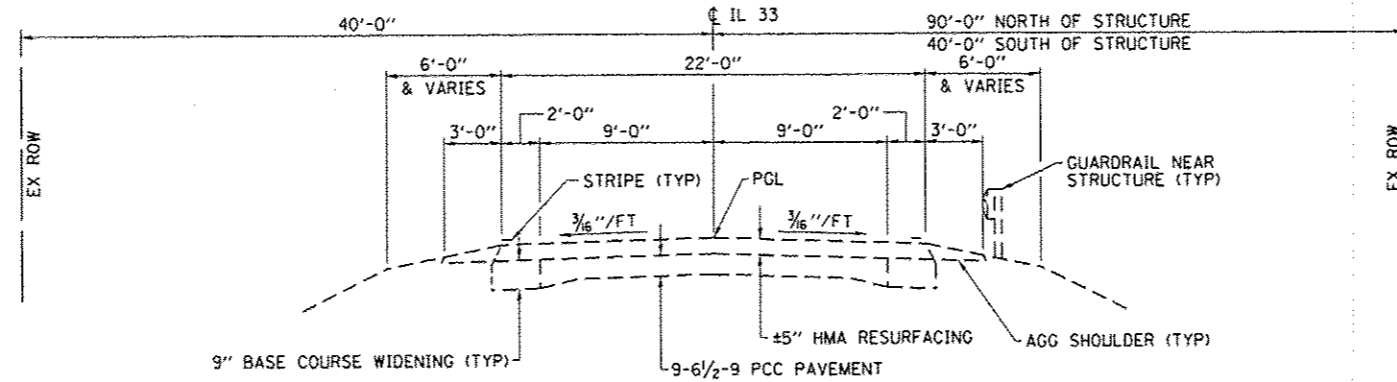

WITHOUT GUARDRAIL WITH GUARDRAIL

**EXISTING TYPICAL ROADWAY SECTION**

STA 701+00 TO 705+13.12  
STA 705+66.88 TO 711+50

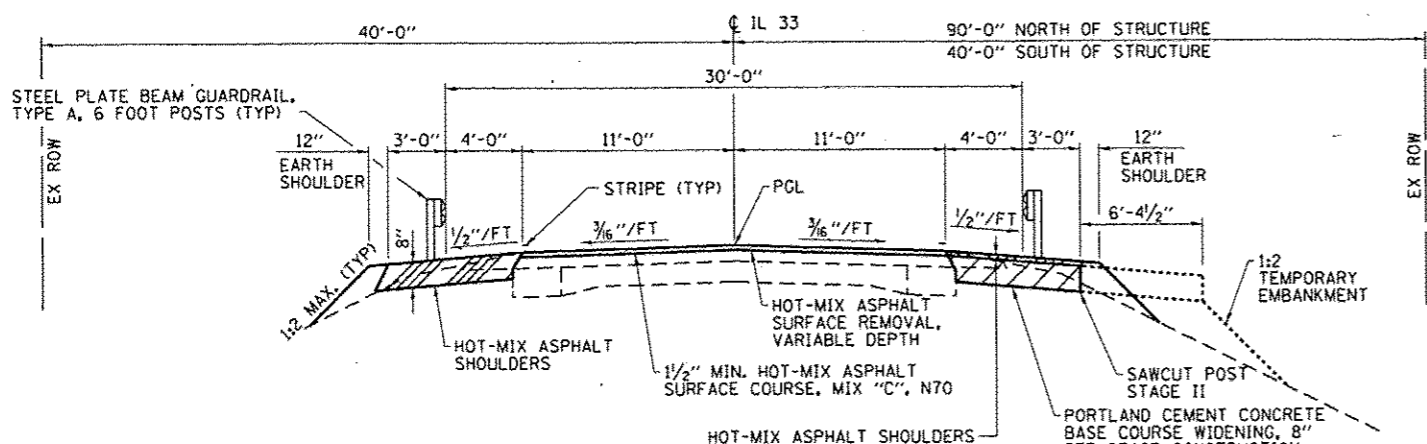

**PROPOSED TYPICAL ROADWAY SECTION**

STA 701+89.5 TO 704+90  
STA 705+90 TO 709+10

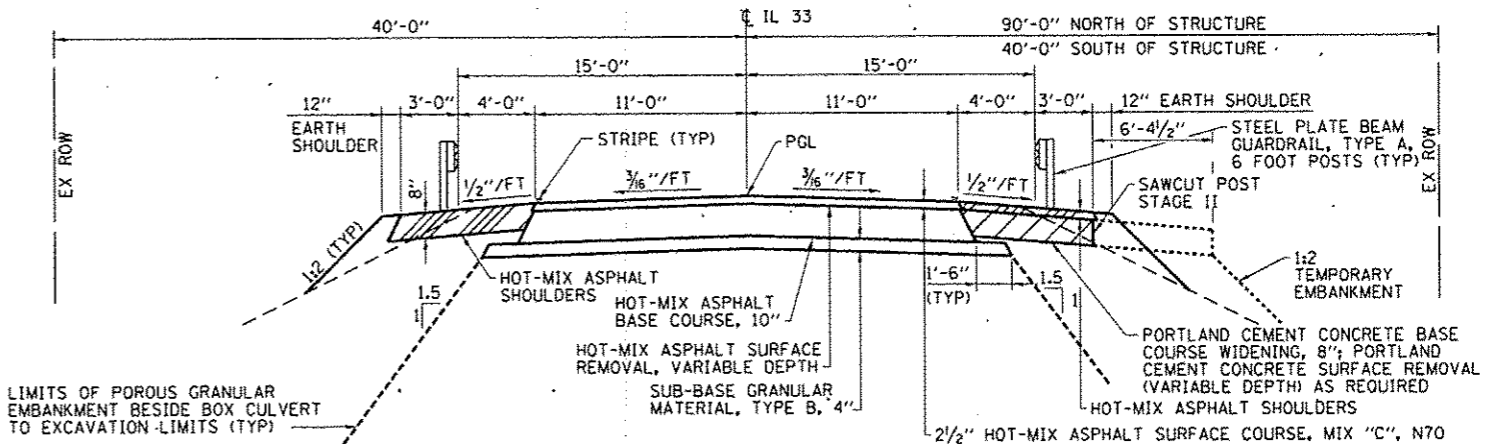

**PROPOSED TYPICAL ROADWAY SECTION**

STA 704+90 TO 705+17.67  
STA 705+62.33 TO 705+90

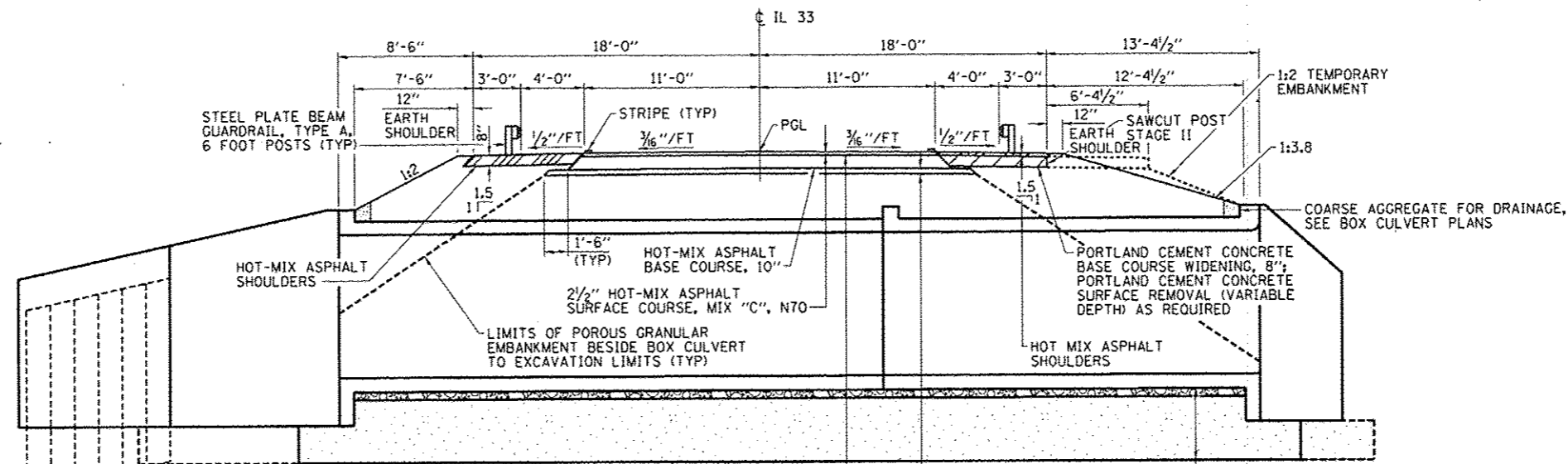

**SECTION THRU BOX CULVERT**

STA 705+17.67 TO 705+62.33

FILE NAME =	USER NAME = staffcarrick	DESIGNED - ELH/DAJ	REVISED -	<b>STATE OF ILLINOIS DEPARTMENT OF TRANSPORTATION</b>	<b>TYPICAL SECTIONS</b>	F.A.P. RTE.	SECTION	COUNTY	TOTAL SHEETS	SHEET NO.	
6P34\Illinois\Projects\K1a6\staffcarrick\08273139\07	68CA-10B-100-033.13	DRAWN - HAS	REVISED -			781	109B-1	LAWRENCE	34	5	
PLOT SCALE = 8.1667" = 1"		CHECKED - ELH	REVISED -			CONTRACT NO. 74105					
PLOT DATE = 6/27/2014 1:33:10 PM		DATE - 06/11	REVISED -			FED. ROAD DIST. NO. ILLINOIS/FED. AID PROJECT AID					



EARTHWORK SCHEDULE						
LOCATION	SUITABLE EARTH EXCAVATION	SUITABLE EARTH EXCAVATION ADJUSTED FOR SHRINKAGE	SUITABLE INCIDENTAL EXCAVATION MATERIAL	SUITABLE INCIDENTAL EXC. MATERIAL ADJUSTED FOR SHRINKAGE	EMBANKMENT (NOT A PAY ITEM)	EARTHWORK BALANCE WASTE (+) OR SHORTAGE (-)
	CU YD	CU YD	CU YD	CU YD	CU YD	CU YD
NE QUADRANT CUTS & FILLS	22	17			34	-17
SE QUADRANT CUTS & FILLS	35	26			82	-56
NW QUADRANT CUTS & FILLS	28	21			46	-25
SW QUADRANT CUTS & FILLS	15	11			90	-79
BOX CULVERT TRENCH TEMPORARY FILL	320	240			275	-35
RIPRAP	90	62			130	-130
						+62
TOTALS	510	377			657	-280

NOTES:  
 1. EXCAVATION USED AS EMBANKMENT = (SUITABLE EARTH EXCAVATION + SUITABLE INCIDENTAL EXCAVATION)\*0.75  
 2. REMOVAL OF TEMPORARY FILL MATERIAL NOT INCLUDED IN SUITABLE EARTH EXCAVATION.

PAVEMENT MARKING SCHEDULE				
LOCATION	DESCRIPTION	SHORT-TERM PAVEMENT MARKING ①	PAINT PAVEMENT MARKING - LINE	TEMP PAVEMENT MARKING - LINE
			4"	4"
STA 701+42.5 TO 709+37.5, C	SKIP-DASH YELLOW CENTERLINE	160	200	200
STA 702+91.5 TO 708+00, RT	SOLID WHITE EDGE LINE		509	509
STA 704+00 TO 708+00, LT	SOLID WHITE EDGE LINE		400	400
TOTALS		160	1109	1109

① INCLUDES 2 ADDITIONAL APPLICATIONS FROM STA 704+00 TO STA 708+00

SEEDING SCHEDULE		
LOCATION	SEEDING, CLASS 2 (SPECIAL)	SEEDING, CLASS 7
	ACRE	ACRE
NE QUADRANT	0.1	0.1
SE QUADRANT	0.1	0.1
NW QUADRANT	0.1	0.1
SW QUADRANT	0.1	0.1
TOTALS	0.4	0.4

AGGREGATE SCHEDULE	
LOCATION	AGGREGATE SURFACE COURSE, TYPE B
	TON
STA 703+92.74, RT	18
STA 704+15.96, LT	2
TOTAL	20

WORK ZONE AND PAVEMENT MARKING REMOVAL SCHEDULE			
LOCATION	PAVEMENT MARKING DESCRIPTION	WORK ZONE PAVEMENT MARKING REMOVAL	PAVEMENT MARKING REMOVAL
		SO FT	SO FT
STA 701+42.5 TO 709+37.5, C	CENTERLINE		220
	CENTERLINE	54	
	CENTERLINE	370	
STA 703+02.5 TO 704+27.5, RT	EDGE LINE		42
STA 706+52.5 TO 707+77.5, RT	EDGE LINE		42
TOTALS		424	304

PAVEMENT REMOVAL SCHEDULE	
LOCATION	PAVEMENT REMOVAL
	SO YD
STA 704+90 TO 705+13.12	57
STA 705+66.88 TO 705+90	57
BASE COURSE WIDENING, POST STAGE II	335
TOTALS	449

TOPSOIL EXCAVATION AND PLACEMENT SCHEDULE	
LOCATION	TOPSOIL EXCAVATION AND PLACEMENT
	CU YD
NE QUADRANT	26
SE QUADRANT	64
NW QUADRANT	46
SW QUADRANT	49
TOTAL	185

GUARDRAIL REMOVAL SCHEDULE	
LOCATION	GUARDRAIL REMOVAL
	FOOT
NE QUADRANT	69
SE QUADRANT	81
NW QUADRANT	81
SW QUADRANT	56
TOTAL	287

PAVING SCHEDULE			
LOCATION	BITUMINOUS MATERIALS (PRIME COAT)	HMA SURFACE COURSE, MIX "C", N70	HMA SHOULDERS
		TON	TON
SN 051-2008	330	105	305
TOTALS	330	105	305

EROSION CONTROL SCHEDULE		
LOCATION	PERIMETER EROSION BARRIER	TEMPORARY EROSION CONTROL SEEDING (2 APPLICATIONS)
	FOOT	POUND
NE QUADRANT	250	20
SE QUADRANT	320	20
NW QUADRANT	295	20
SW QUADRANT	270	20
TOTALS	1135	80

BASE COURSE SCHEDULE		
LOCATION	HMA BASE COURSE, 10"	PCC BASE COURSE WIDENING, 8"
	SO YD	SO YD
STA 702+91.5 TO 707+88.5, RT		739
STA 704+90 TO 705+90	250	
TOTALS	250	739

SURFACE REMOVAL SCHEDULE		
LOCATION	HMA SURFACE REMOVAL, VARIABLE DEPTH	PCC SURFACE REMOVAL (VARIABLE DEPTH)
	SO YD	SO YD
STA 704+00 TO 708+00	980	
BASE COURSE WIDENING		404
TOTAL	980	404

SUB-BASE GRANULAR MATERIAL SCHEDULE	
LOCATION	SUB-BASE GRANULAR MATERIAL, TYPE B 4"
	SO YD
STA 704+90 TO 705+90	301
TOTAL	301

POROUS GRANULAR EMBANKMENT SCHEDULE	
LOCATION	POROUS GRANULAR EMBANKMENT
	CU YD
BOX CULVERT TRENCH	640
TOTAL	640

GUARDRAIL SCHEDULE				
LOCATION	TRAFFIC BARRIER TERMINAL, TYPE 1 (SPECIAL) TANGENT	GUARDRAIL MARKERS, TYPE A	STEEL PLATE BEAM GUARDRAIL, TY A	TERMINAL MARKER DIRECT APPLIED
	EACH	EACH	FOOT	EACH
NE QUADRANT	3	2		3
SE QUADRANT	1	4	350	1
NW QUADRANT	3	3	62.5	3
SW QUADRANT	1	2	200	1
TOTALS	8	11	612.5	8



PLAN	DATE
NO.	BY
NO.	BY
NO.	BY
NO.	BY

PROFILE	DATE
NO.	BY
NO.	BY
NO.	BY
NO.	BY

SEC. 33, T5N, R10W, 3RD P.M.

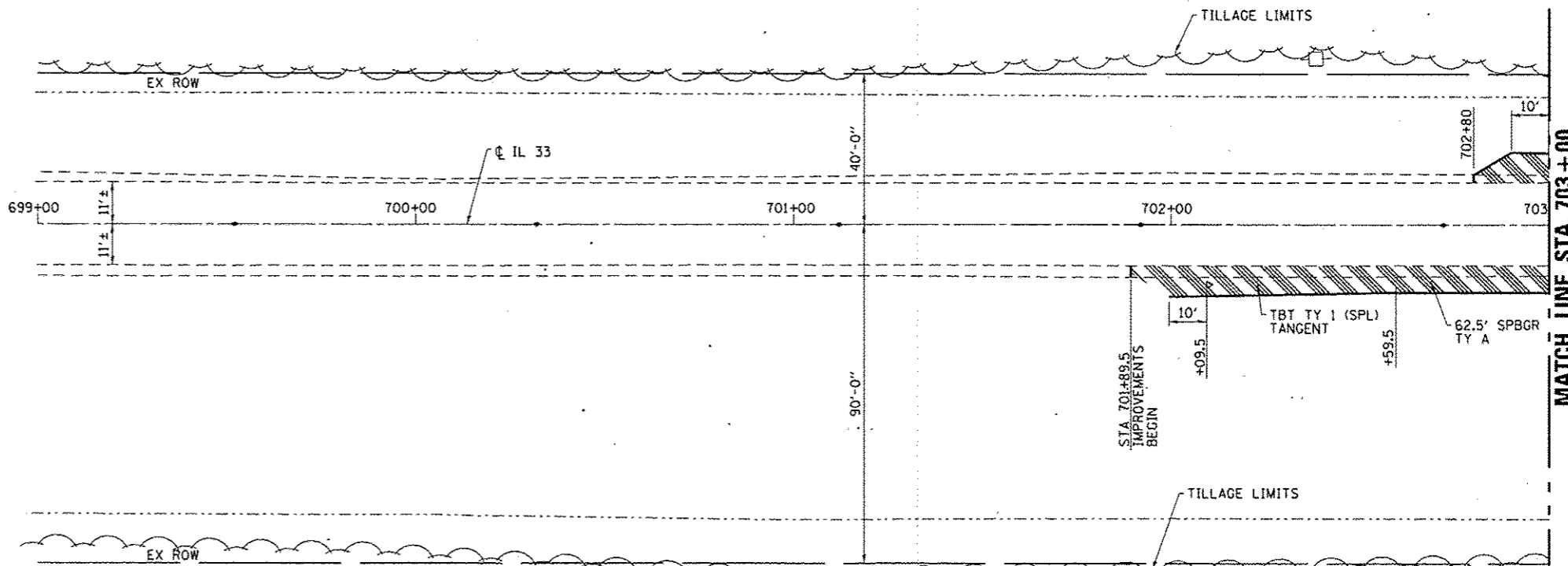
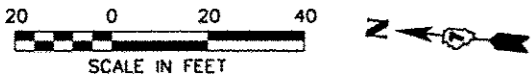

MATCH LINE STA. 703+00  
SEE SHT. 8 FOR CONT.

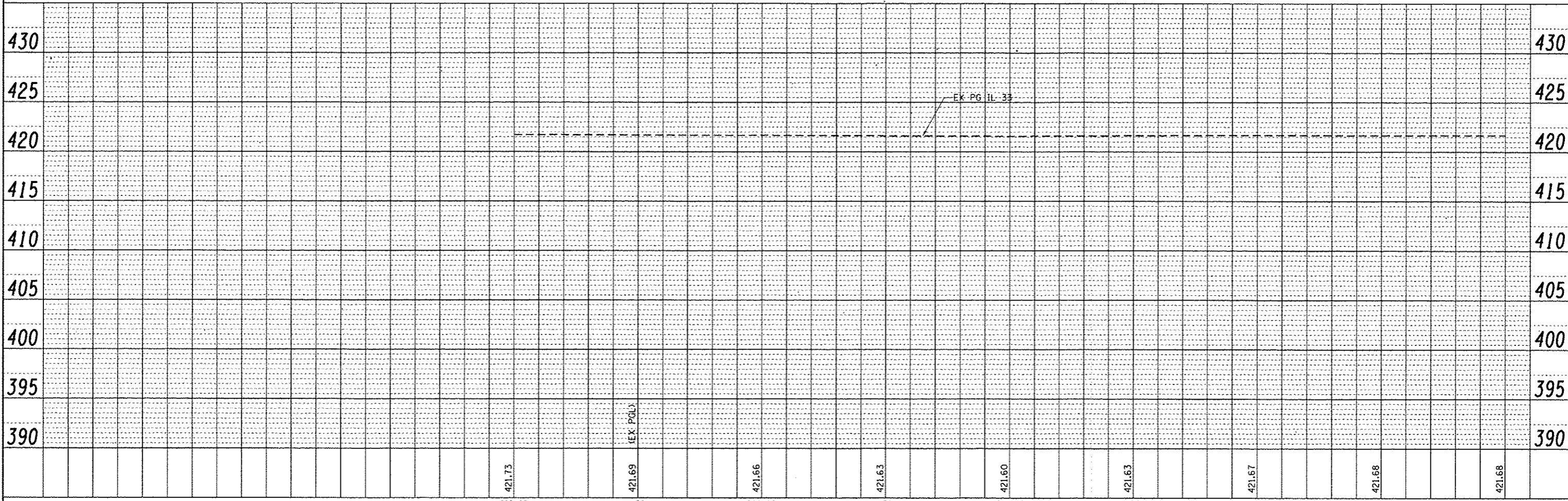
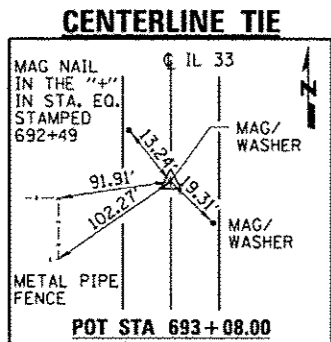

FILE NAME =	USER NAME = staff@fsc.com	DESIGNED - DAJ	REVISED -	<b>STATE OF ILLINOIS DEPARTMENT OF TRANSPORTATION</b>	<b>FAP RTE 781 (IL 33) PLAN AND PROFILE</b>	F.A.P. RTE. 781	SECTION 109B-1	COUNTY LAWRENCE	TOTAL SHEETS 34	SHEET NO. 7
SCALE: (HORIZ) 1"=40' (VERT) 1"=5'	PLOT DATE = 6/27/2014 1:06:24 PM	DRAWN - HAS	REVISED -			CONTRACT NO. 74105				
		CHECKED - ELH	REVISED -			FED. ROAD DIST. NO. ILLINOIS FED. AID PROJECT				
		DATE - 05/10	REVISED -			SCALE: 1"=20'-0" SHEET NO. 1 OF 3 SHEETS STA. 699+00 TO STA. 703+00				



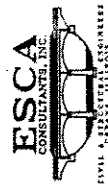

PLAN	DATE
BY	
REVISIONS	
NO.	
DATE	
BY	
REVISIONS	
NO.	
DATE	
BY	
REVISIONS	
NO.	
DATE	

PROFILE	DATE
BY	
REVISIONS	
NO.	
DATE	
BY	
REVISIONS	
NO.	
DATE	
BY	
REVISIONS	
NO.	
DATE	

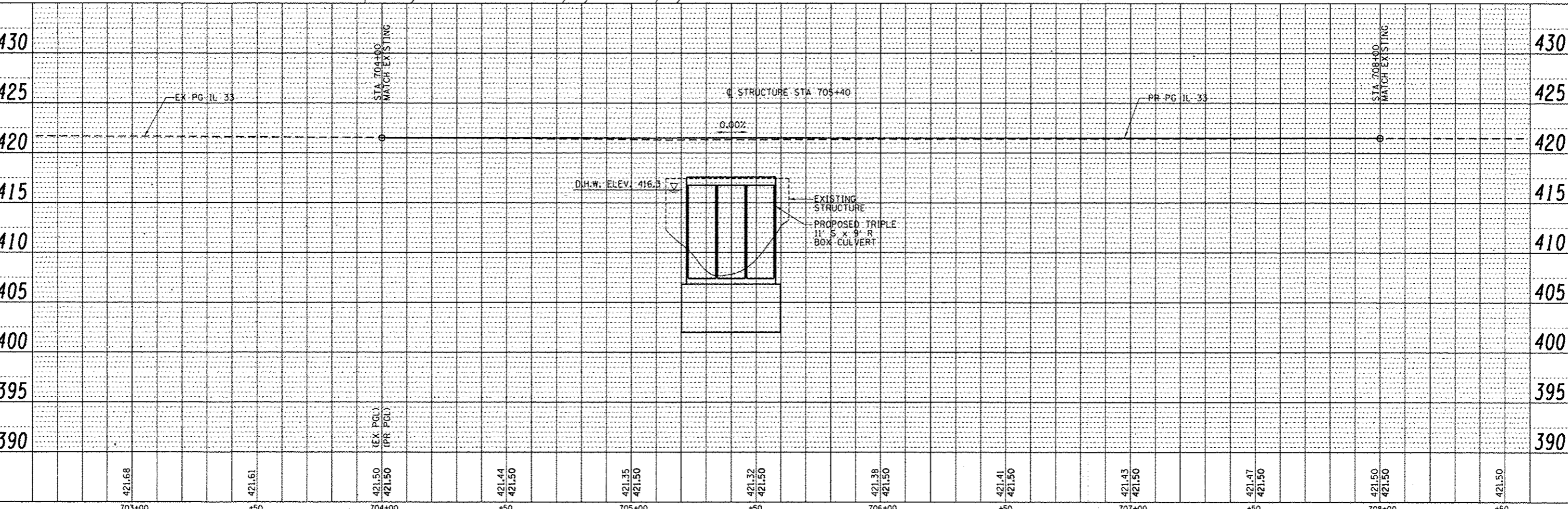
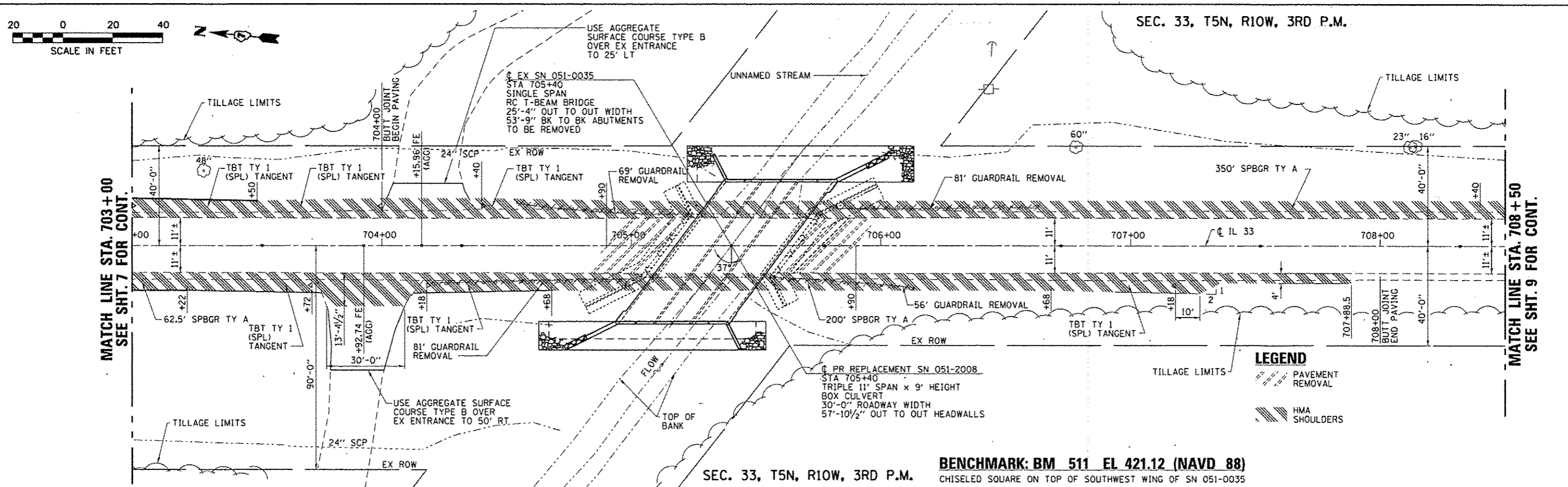

FILE NAME: D774105-sh1-plnpr F82.dgn	USER NAME: staffanmk	DESIGNED: DAJ	REVISED:	STATE OF ILLINOIS DEPARTMENT OF TRANSPORTATION		F.A.P. RTE. 781	SECTION 109B-1	COUNTY LAWRENCE	TOTAL SHEETS 34	SHEET NO. 8
ESCA JOB NO. 933.13	PLOT SCALE: 0.16667' / in.	DRAWN: HAS	REVISED:	FAP RTE 781 (IL 33) PLAN AND PROFILE		SHEET NO. 2 OF 3 SHEETS		CONTRACT NO. 74105	FED. ROAD DIST. NO. ILLINOIS FED. AID PROJECT	
PLOT DATE: 6/2/2014	1:00:00 PM	CHECKED: ELH	REVISED:	SCALE: 1"=20'-0"		SHEET NO. 2 OF 3 SHEETS		STA. 703+00 TO STA. 708+50		
DATE: 05/10		REVISIONS:								

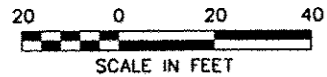

SEC. 33, T5N, R10W, 3RD P.M.

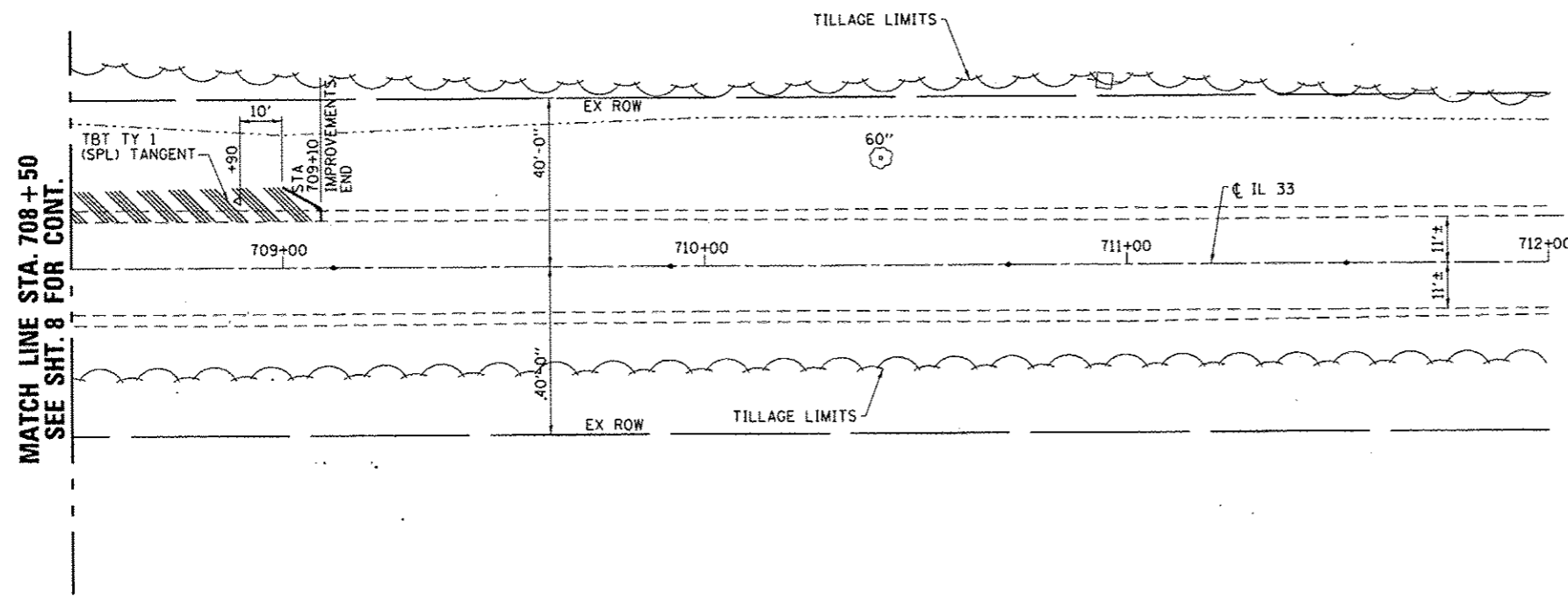

MATCH LINE STA. 708+50  
SEE SHT. 8 FOR CONT.

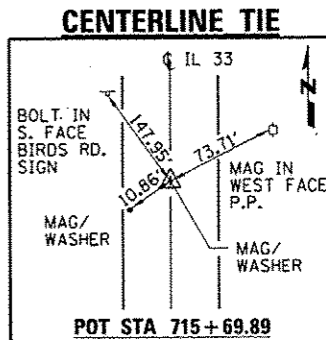

SEC. 33, T5N, R10W, 3RD P.M.

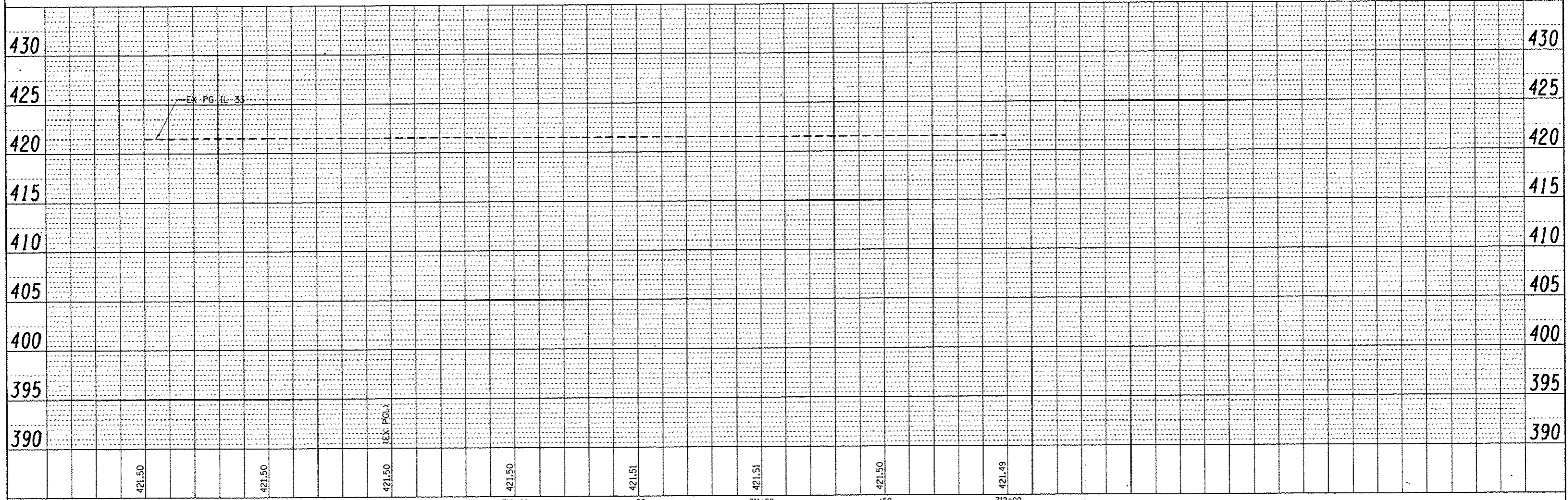

PLAN	DATE
BY	
DESIGNED	
DRAWN	
CHECKED	
DATE	

PROFILE	DATE
BY	
DESIGNED	
DRAWN	
CHECKED	
DATE	

FILE NAME : 0774105-shc-plnprf03.dgn	USER NAME : staffernk	DESIGNED - DAJ	REVISED -	<b>STATE OF ILLINOIS DEPARTMENT OF TRANSPORTATION</b>	<b>FAP RTE 781 (IL 33) PLAN AND PROFILE</b>		F.A.P. RTE. 781	SECTION 109B-1	COUNTY LAWRENCE	TOTAL SHEETS 34	SHEET NO. 9	
ESCA JOB NO. 933.13	DRAWN - HAS	CHECKED - ELH	REVISED -		SCALE: 1"=20'-0"	SHEET NO. 3 OF 3 SHEETS	STA. 708+50 TO STA. 712+00	CONTRACT NO. 74105				
PLOT SCALE : 0.18667 / 1 in.	CHECKED - ELH	REVISED -	REVISED -		FED. ROAD DIST. NO. ILLINOIS FED. AID PROJECT							
PLOT DATE : 6/2/2014 1:09:57 PM	DATE - 05/10	REVISED -	REVISED -									

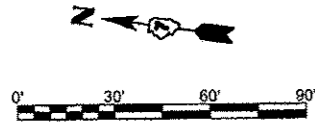

- LEGEND**
- TRAFFIC SIGNAL WITH BACKPLATE, SIGNAL DIRECTION INDICATED
  - PCC BASE COURSE WIDENING, 8"
  - PAVEMENT REMOVAL

**SCHEDULE OF QUANTITIES**

STATION TO	STATION	FEET
704+52.5	706+40	187.5
		TOTAL 187.5
TEMPORARY CONCRETE BARRIER		
		TEMPORARY BRIDGE TRAFFIC SIGNALS - 1 EACH
		TEMPORARY RUMBLE STRIPS - 6 EACH
IMPACT ATTENUATORS, TEMPORARY (NON-REDIRECTIVE), TEST LEVEL 3 - 2 EACH		

**GENERAL NOTES**

1. TRAFFIC CONTROL SHALL BE ERECTED AS SHOWN AND ACCORDING TO "TRAFFIC CONTROL AND PROTECTION, STANDARD 701321."
2. SEE SPECIAL PROVISIONS FOR ADDITIONAL TRAFFIC CONTROL REQUIREMENTS.
3. COORDINATE LOCATION OF SIGNALS WITH FINAL WORK AS DIRECTED BY THE ENGINEER.
4. CONSTRUCT TEMPORARY RUMBLE STRIPS AT LOCATIONS SHOWN ON STANDARD 701321.
5. ADDITIONAL SIGNAGE FOR SIDE-ROADS AND ENTRANCES SHALL BE INCLUDED IN THE COST OF STANDARD 701321.
6. THE DIMENSION SHOWN ON THE WIDTH RESTRICTION SIGN (W2-1102(O)-48) SHOWN ON STANDARD 701321 SHALL BE 12'-4" FOR STAGE I CONSTRUCTION.

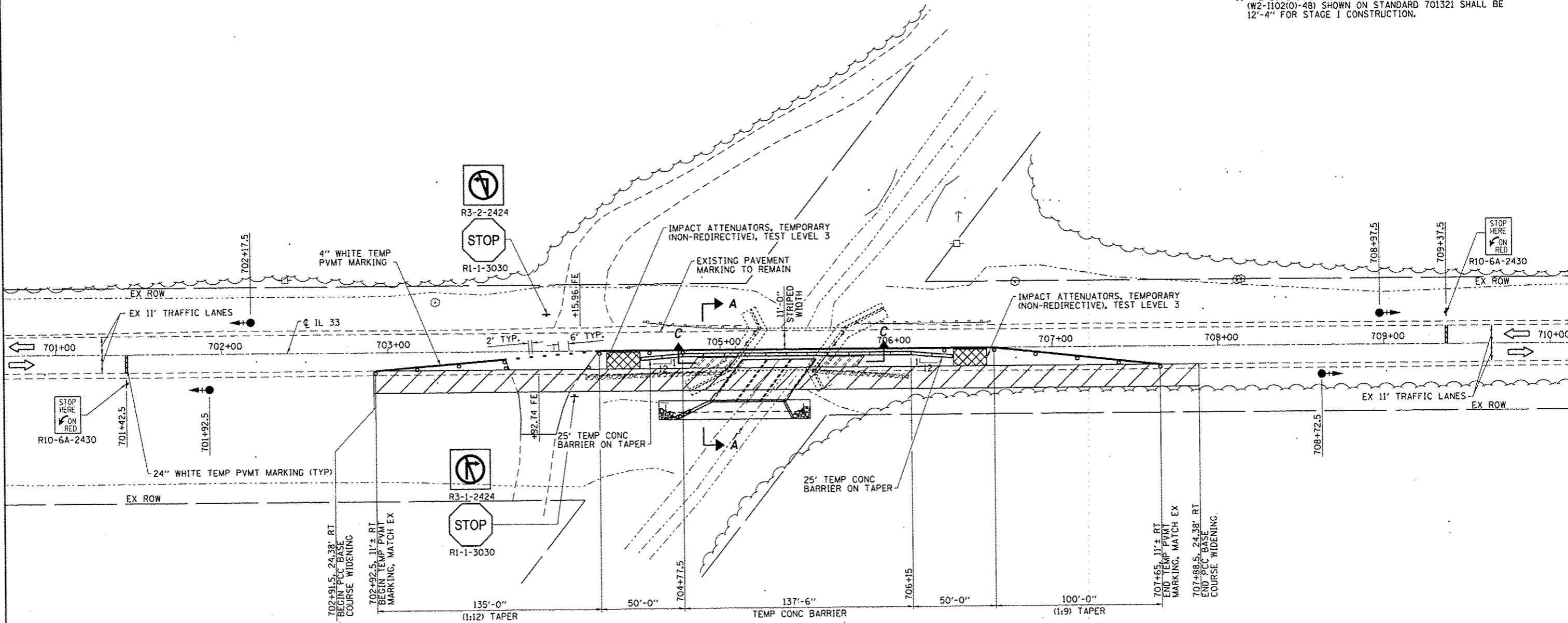

FILE NAME = 0724261010\p202014\B&E\m\0273129\07	USER NAME = staffennk	DESIGNED - DAJ	REVISED -	<b>STATE OF ILLINOIS DEPARTMENT OF TRANSPORTATION</b>	<b>STAGE I CONSTRUCTION</b>	F.A.P. RTE. 781	SECTION 1098-1	COUNTY LAWRENCE	TOTAL SHEETS 34	SHEET NO. 10
	PLT SCALE = 0.1667 "/td> <td>CHECKED - ELH</td> <td>REVISED -</td> <td>SCALE: 1"=30'-0"</td> <td>SHEET NO. 1 OF 2 SHEETS</td> <td>STA. 700+68.65 TO STA. 710+13.64</td> <td>FED. ROAD DIST. NO. ILLINOIS</td> <td>FED. AID PROJECT</td> <td colspan="2">CONTRACT NO. 74105</td>	CHECKED - ELH	REVISED -			SCALE: 1"=30'-0"	SHEET NO. 1 OF 2 SHEETS	STA. 700+68.65 TO STA. 710+13.64	FED. ROAD DIST. NO. ILLINOIS	FED. AID PROJECT
PLT DATE = 6/2/2014	1:38:27 PM	DATE - 06/11	REVISED -							

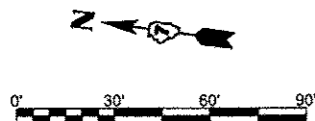

**LEGEND**

- TRAFFIC SIGNAL WITH BACKPLATE, SIGNAL DIRECTION INDICATED
- PCC BASE COURSE WIDENING, 8"
- PAVEMENT REMOVAL

**SCHEDULE OF QUANTITIES**

TEMPORARY CONCRETE BARRIER			
STATION TO	STATION	FEET	
703+02.5	704+52.5	150	
706+40	707+77.5	137.5	
703+27.5	707+52.5	425	
	TOTAL	712.5	

RELOCATE TEMPORARY CONCRETE BARRIER			
STATION TO	STATION	FEET	
704+52.5	706+40	187.5	
	TOTAL	187.5	

IMPACT ATTENUATORS, RELOCATE (NON-REDIRECTIVE), TEST LEVEL 3 - 2 EACH

IMPACT ATTENUATORS, TEMPORARY (FULLY REDIRECTIVE, NARROW), TEST LEVEL 3 - 2 EACH

**GENERAL NOTES**

- TRAFFIC CONTROL SHALL BE ERECTED AS SHOWN AND ACCORDING TO "TRAFFIC CONTROL AND PROTECTION, STANDARD 701321."
- SEE SPECIAL PROVISIONS FOR ADDITIONAL TRAFFIC CONTROL REQUIREMENTS.
- COORDINATE LOCATION OF SIGNALS WITH FINAL WORK AS DIRECTED BY THE ENGINEER.
- CONSTRUCT TEMPORARY RUMBLE STRIPS AT LOCATIONS SHOWN ON STANDARD 701321.
- ADDITIONAL SIGNAGE FOR SIDE-ROADS AND ENTRANCES SHALL BE INCLUDED IN THE COST OF STANDARD 701321. THE TWO FIELD ENTRANCES SHALL BE CLOSED DURING STAGE II CONSTRUCTION PER STANDARD 701901.
- THE DIMENSION SHOWN ON THE WIDTH RESTRICTION SIGN (W2-1102(0)-48) SHOWN ON STANDARD 701321 SHALL BE 10'-6" FOR STAGE II CONSTRUCTION.

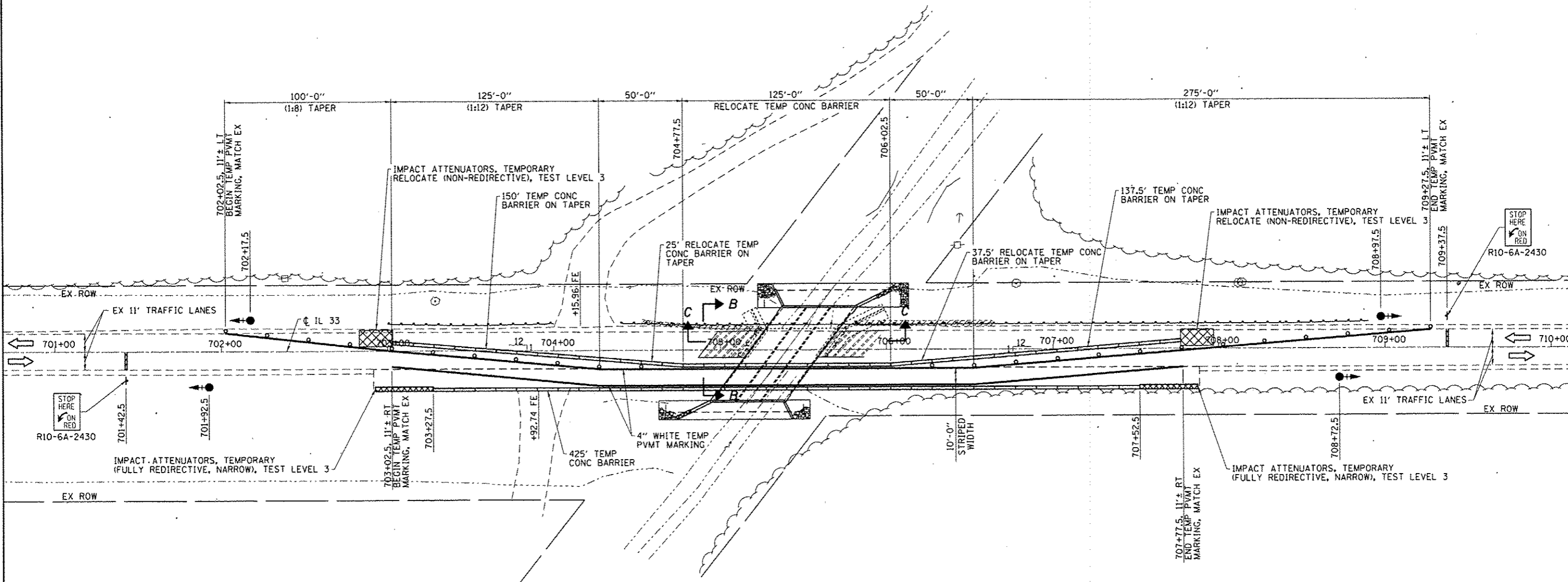

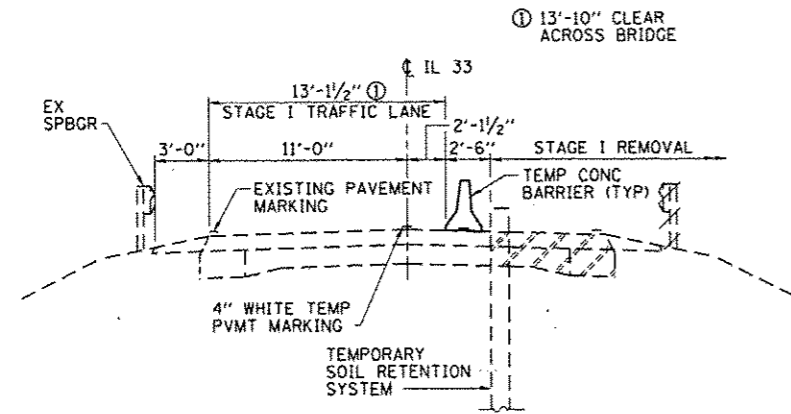

**SECTION A-A  
(STAGE I)**

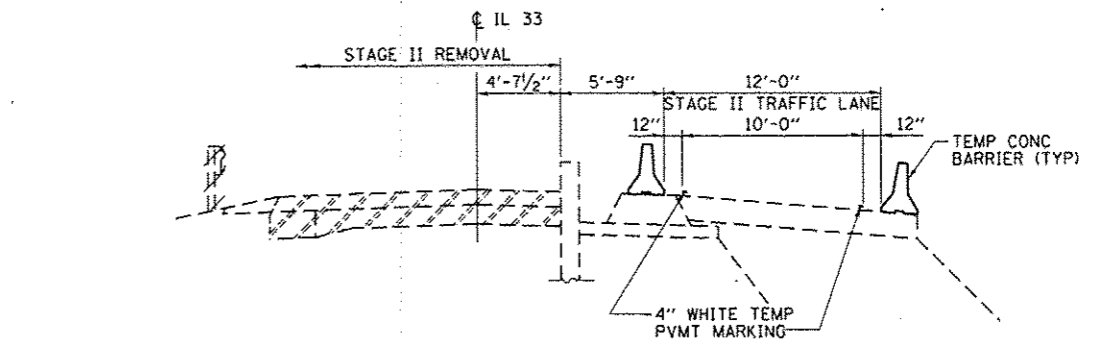
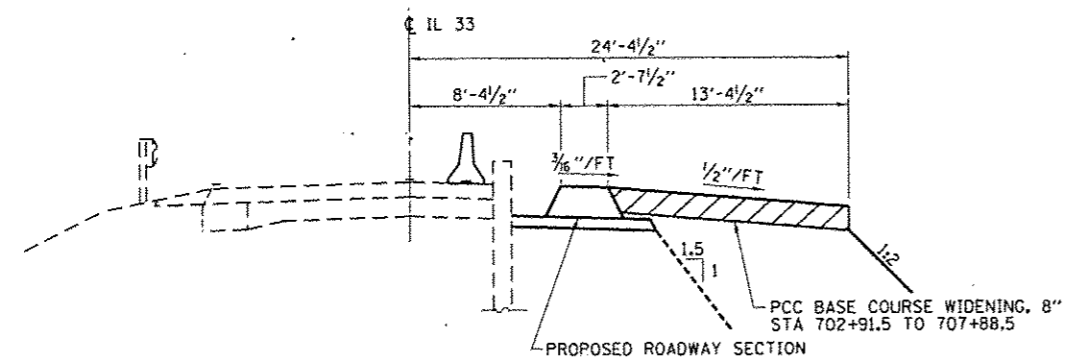

**SECTION B-B  
(STAGE II)**

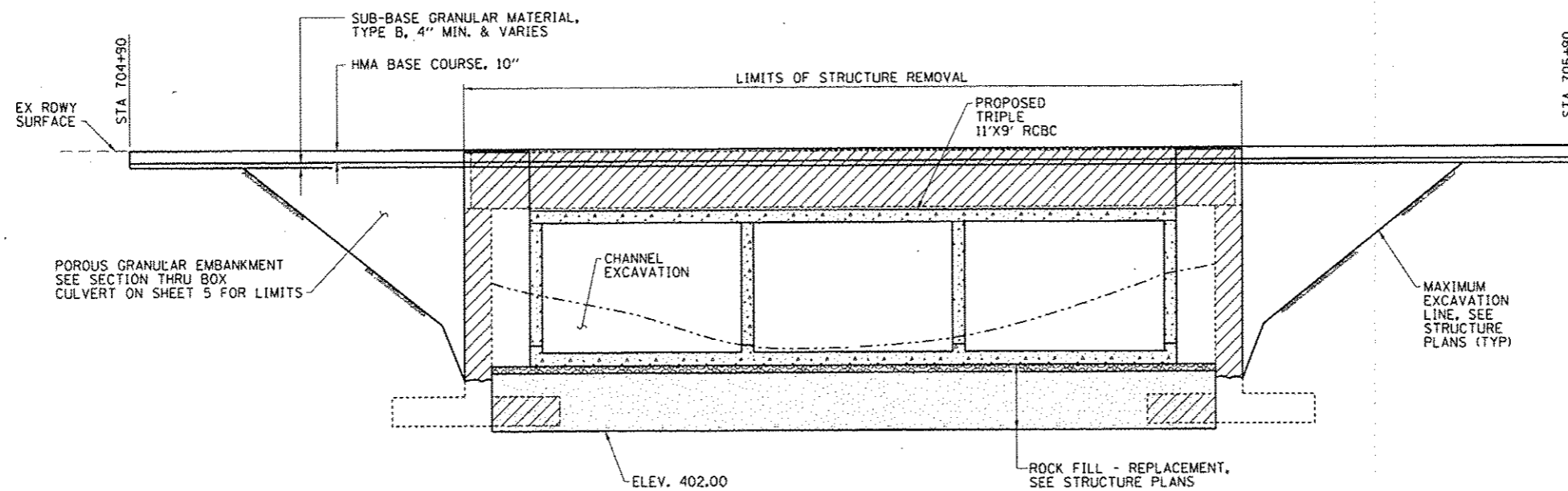
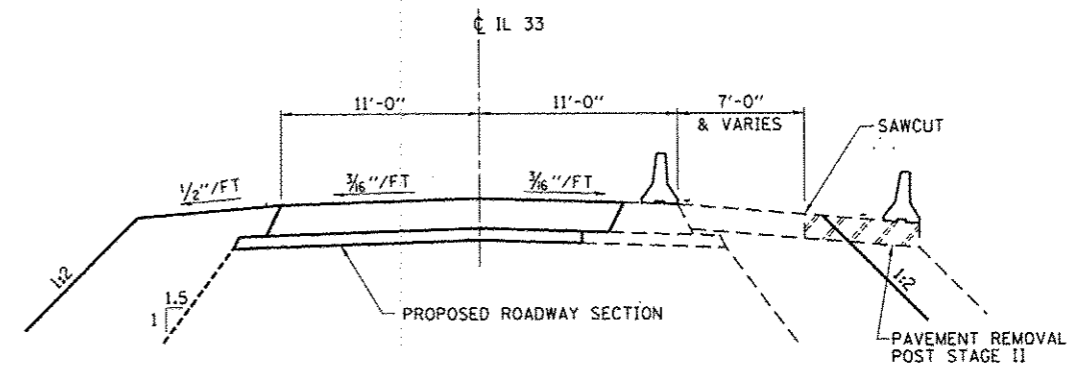

**SECTION C-C**

FILE NAME =	USER NAME = asofftanrk	DESIGNED - DAJ	REVISED -	<b>STATE OF ILLINOIS DEPARTMENT OF TRANSPORTATION</b>	<b>STAGE CONSTRUCTION DETAILS</b>	F.A.P. RTE. =	SECTION	COUNTY	TOTAL SHEETS	SHEET NO.	
892426mk\p\del\1a\2\Fgmnk\0273109\07	02/21/2014 11:59:11 AM	DRAWN - HAS	REVISED -			781	109B-1	LAWRENCE	34	12	
PLOT SCALE = 0.1067 1/2 in.		CHECKED - ELH	REVISED -			CONTRACT NO. 74105					
PLOT DATE = 6/2/2014 11:59:11 AM		DATE - 06/11	REVISED -			FED. ROAD DIST. NO.   ILLINOIS FED. AID PROJECT AID					
						SCALE:	SHEET NO. 1 OF 1 SHEETS	STA.	TO STA.		

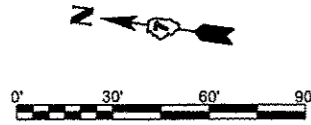

**LEGEND**

- APPROXIMATE SEEDING AND MULCH AREAS
- PERIMETER EROSION BARRIER
- ▨ STONE RIPRAP, CLASS A4
- - - CONSTRUCTION LIMITS
- /// HOT-MIX ASPHALT SHOULDERS

EX SN 051-0035  
STA 705+40  
SINGLE SPAN  
RC T-BEAM BRIDGE  
25'-4" OUT TO OUT WIDTH  
53'-9" BK TO BK ABUTMENTS  
TO BE REMOVED

PR REPLACEMENT SN 051-2008  
STA 705+40  
TRIPLE 11' SPAN x 9' HEIGHT  
BOX CULVERT  
30'-0" ROADWAY WIDTH  
57'-10 1/2" OUT TO OUT HEADWALLS

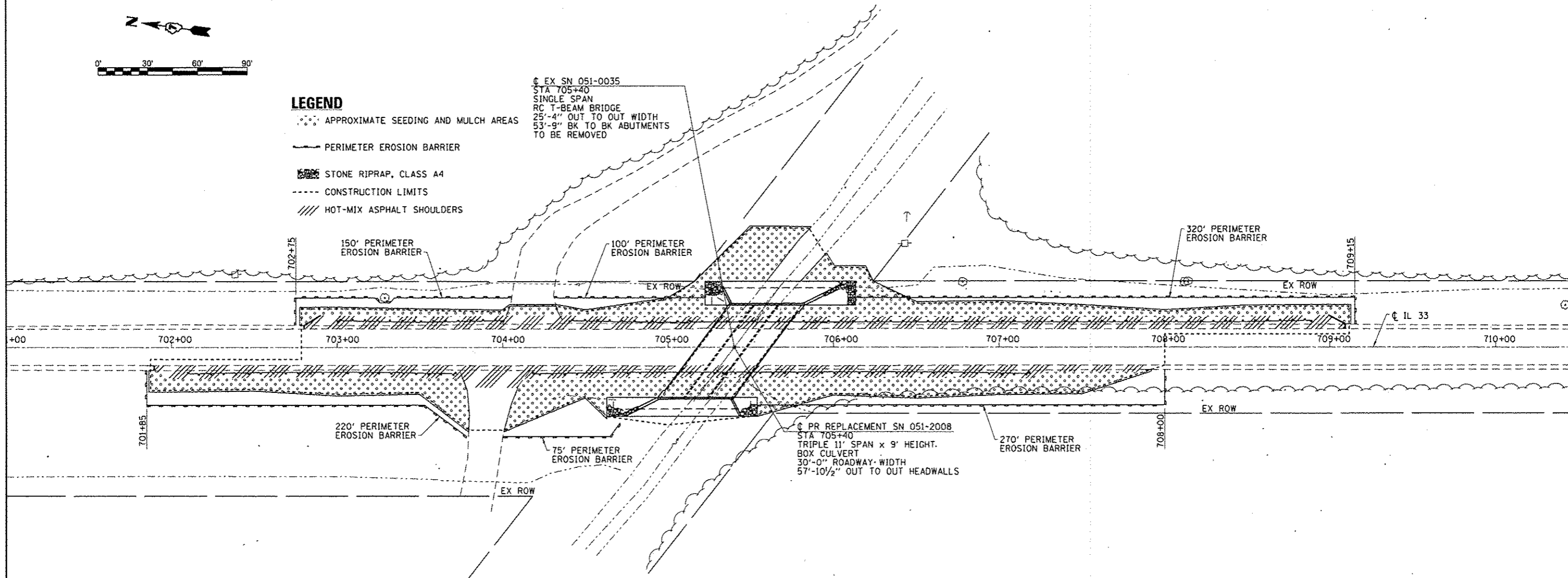

FILE NAME : B:\2410\work\perdo\1212\121273139\07	USER NAME : steffarnk	DESIGNED - DAJ	REVISED -	<b>STATE OF ILLINOIS DEPARTMENT OF TRANSPORTATION</b>	<b>EROSION CONTROL AND DRAINAGE PLAN</b>	F.A.P. RTE. 781	SECTION 109B-1	COUNTY LAWRENCE	TOTAL SHEETS 34	SHEET NO. 13	
PLOT SCALE : 0.1867 1/2 in.	CHECKED - ELH	REVISED -	SCALE: 1"=30'-0"			SHEET NO. 1 OF 1 SHEETS	STA. 701+00 TO STA. 710+50	FED. ROAD DIST. NO. ILLINOIS FED. AID PROJECT			
PLOT DATE : 6/2/2014 12:00:43 PM	DATE - 06/11	REVISED -									
CONTRACT NO. 74105											

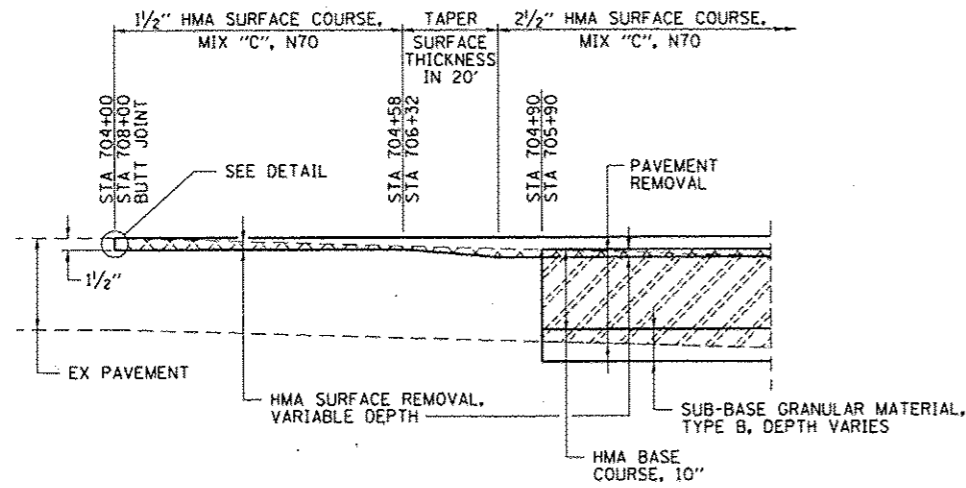

**SURFACING AND MILLING SECTION**

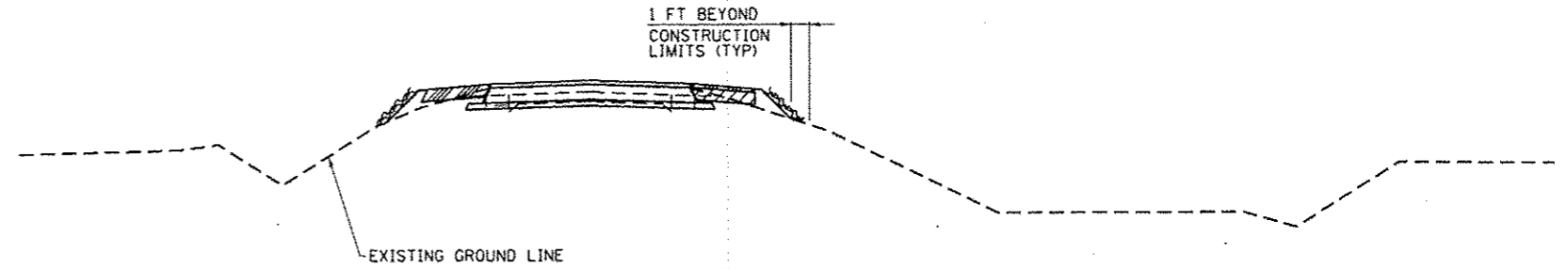

**SEEDING & MULCHING**

**GENERAL NOTES**

IN GENERAL, ALL EARTH SURFACES DISTURBED DURING CONSTRUCTION OPERATIONS SHALL BE SEEDED AND MULCHED UPON COMPLETION OF ALL GRADING OPERATIONS.

FERTILIZER NUTRIENTS AND LIMESTONE SHALL BE APPLIED TO ALL SEEDED AREAS.

THE RATES OF APPLICATION OF FERTILIZER, MULCH AND LIMESTONE SHALL BE AS SPECIFIED IN THE SPECIAL PROVISIONS.

SECTIONS 250 AND 251 OF THE STANDARD SPECIFICATIONS SHALL GOVERN THIS WORK EXCEPT AS SPECIFIED HEREIN OR AS NOTED IN THE SPECIAL PROVISIONS.

INDICATES LIMITS OF SEEDING AND MULCHING

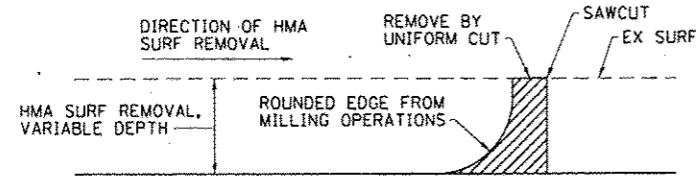

**DETAIL AT BUTT JOINT**

NOTE:  
WHEN MILLING OPERATIONS PRODUCE A ROUNDED EDGE, THEN A SAWCUT SHALL BE USED TO MANUFACTURE A PERPENDICULAR EDGE AS SHOWN IN THE DETAIL. THE COST OF ALL WORK SHOWN IN THE DETAIL IS INCLUDED IN HOT-MIX ASPHALT SURFACE REMOVAL, VARIABLE DEPTH. THE ENGINEER SHALL BE THE SOLE JUDGE CONCERNING THE USE OF THIS DETAIL.

FILE NAME =	USER NAME = steffernk	DESIGNED - DAJ	REVISED -	STATE OF ILLINOIS DEPARTMENT OF TRANSPORTATION	MISCELLANEOUS DETAILS	F.A.P. RTE.	SECTION	COUNTY	TOTAL SHEETS	SHEET NO.
09/24/2011 11:58:02 AM	ESCA-08-11033.13	DRAWN - HAS	REVISED -			781	109B-1	LAWRENCE	34	14
PLOT SCALE = 0.1667 1/16"		CHECKED - ELH	REVISED -			CONTRACT NO. 74105				
PLOT DATE = 6/2/2014 11:58:02 AM		DATE - 06/11	REVISED -			SCALE:		SHEET NO. 1 OF 1 SHEETS		STA.

BENCHMARK: BM 511-Chiseled square on top of southwest wing of SN 051-0035, Elev. 421.12 (NAVD 88)

EXISTING STRUCTURE: SN 051-0035 was originally built in 1933 as SBI 181, Section 109B. The original brick railing was removed and replaced with a steel rail. The date of this work is unknown. It is a single span reinforced concrete tee beam structure on concrete abutments and wingwalls supported on timber piles. The deck width is 25'-4" and the length is 50'-0" face to face of abutments. The structure was constructed at a 37° skew. Traffic shall be maintained utilizing stage construction.

No salvage.

STATE OF ILLINOIS  
DEPARTMENT OF TRANSPORTATION

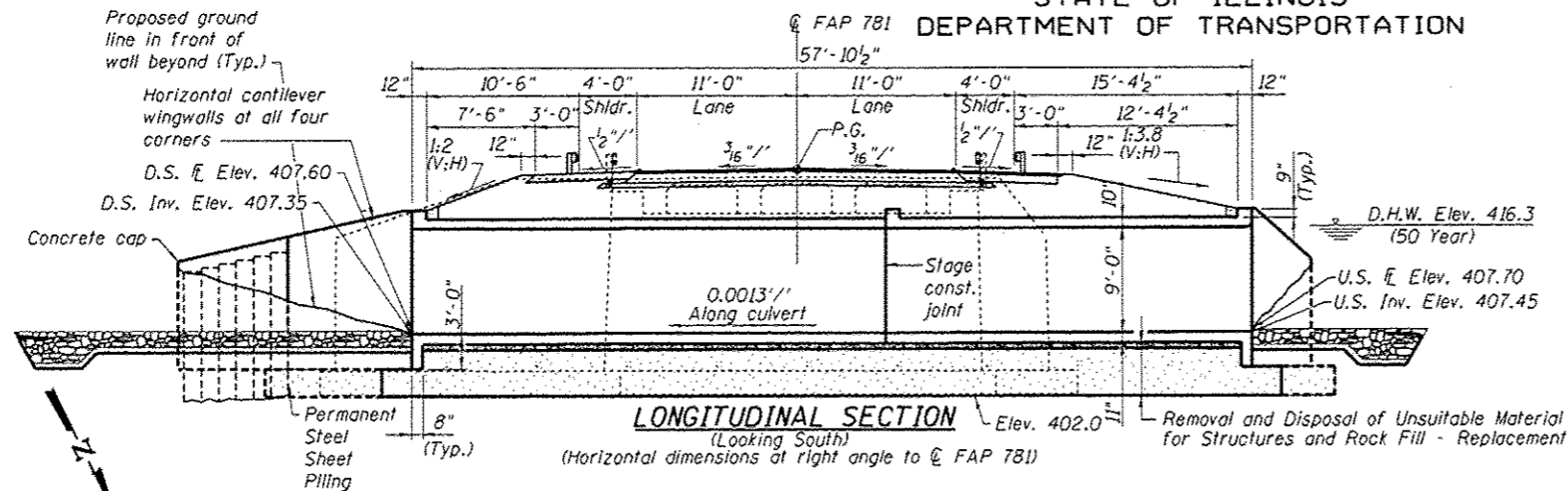

STRUCTURE INDEX OF SHEETS

General Plan	Sheet No. 1 of 10
General Data	Sheet No. 2 of 10
Stage Construction Details	Sheet No. 3 & 4 of 10
Box Culvert Details	Sheet No. 5 & 6 of 10
Steel Sheet Piling Wall Details	Sheet No. 7 of 10
Bar Splicer Assembly Details	Sheet No. 8 of 10
Temporary Concrete Barrier For Stage Construction	Sheet No. 9 of 10
Boring Logs	Sheet No. 10 of 10

SCOUR INFORMATION

Design Scour Elevation (Ft.)	Downstream	Upstream
	404.35	404.45

**APPROVED**  
For Structural Adequacy Only

*D. Carl Perry*  
Engineer of Bridges & Structures

DESIGN STRESSES

FIELD UNITS

$f'_c = 3,500$  psi  
 $f_y = 60,000$  psi (Reinf.)

DESIGN SPECIFICATIONS

2002 AASHTO

LOADING HS20-44

Allow 50 psf for future wearing surface.

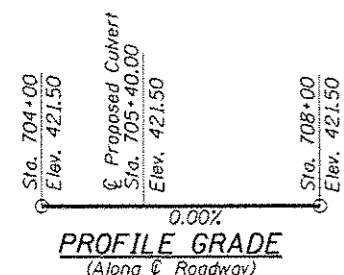
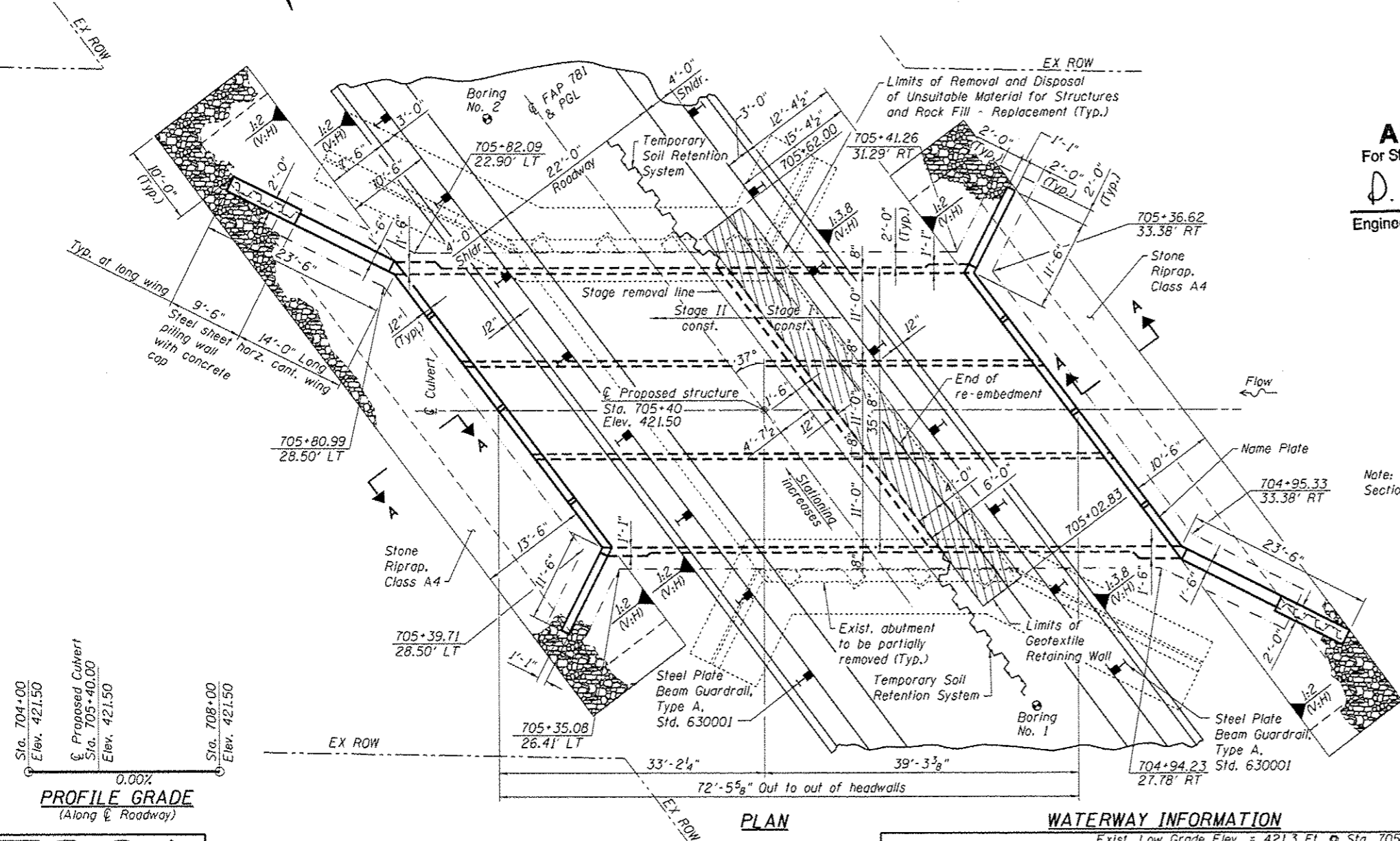

WATERWAY INFORMATION

Drainage Area = 2.33 Sq. Mi.    Exist. Low Grade Elev. = 421.3 Ft. @ Sta. 705+05  
Prop. Low Grade Elev. = 421.50 Ft. @ Sta. 705+05

Flood	Freq. Yr.	C.F.S.	Opening - Sq. Ft.		Nat. H.W.E.	Head - Ft.		Headwater El.	
			Exist.	Prop.		Exist.	Prop.	Exist.	Prop.
10	462	186	232	414.4	0.0	0.0	414.4	414.4	
Design	50	739	257	291	416.3	0.0	0.0	416.3	416.3
Base	100	863	285	297	417.0	0.0	0.0	417.0	417.0
Max. Calc.	500	1160	304	297	418.5	0.2	0.2	418.7	418.7

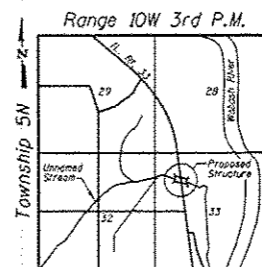

LOCATION SKETCH



EXPIRES 11-30-10

*D. Carl Perry*  
SIGNATURE

06-30-10  
DATE

GENERAL PLAN  
IL 33 OVER UNNAMED STREAM  
FAP ROUTE 781 - SECTION 109B-1  
LAWRENCE COUNTY  
STATION 705+40  
STRUCTURE NO. 051-2008

SHEET NO. 1 10 SHEETS	F.A.P. RTE.	SECTION	COUNTY	TOTAL SHEETS	SHEET NO.
	781	109B-1	LAWRENCE	34	15
CONTRACT NO. 74105					
FED. ROAD DIST. NO.    ILLINOIS FED. AID PROJECT					

**ESCA**  
CONSULTANTS, INC.

DESIGNED BY:	ELH	03/10
DRAWN BY:	DWH/HAS	03/10
CHECKED BY:	ELH	06/10
APPROVED BY:	RDP	06/10



STATE OF ILLINOIS  
DEPARTMENT OF TRANSPORTATION

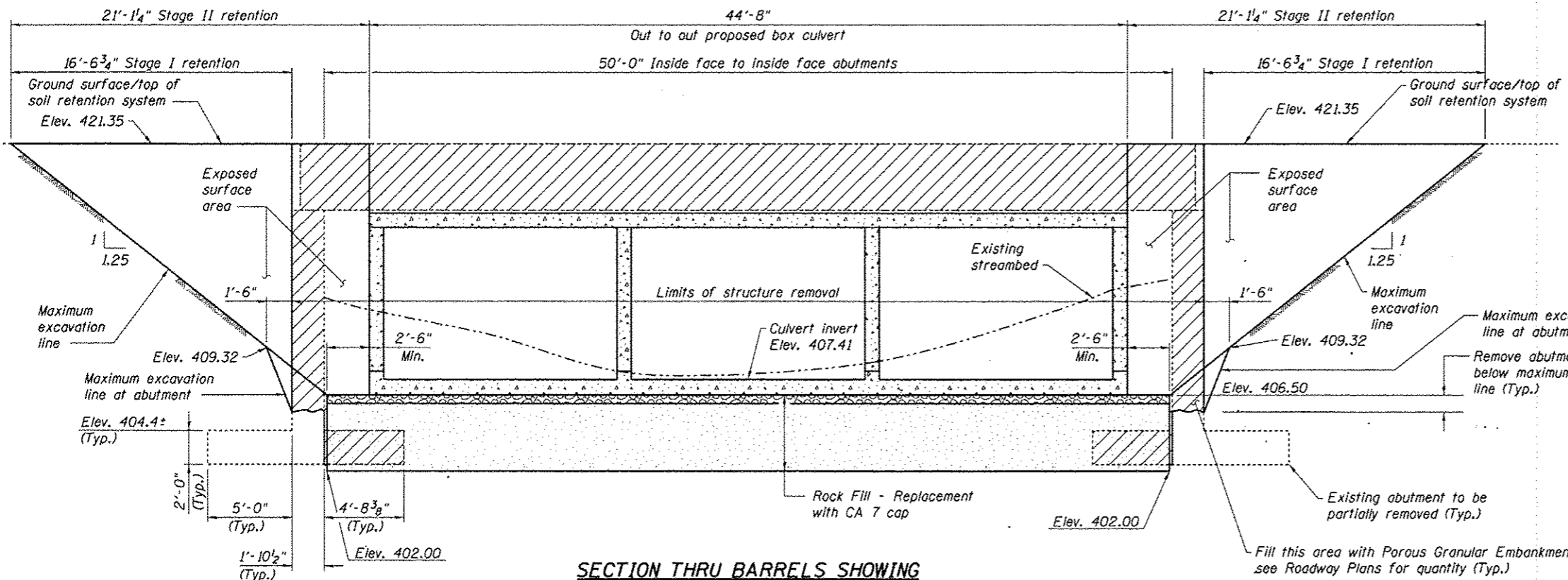

**SECTION THRU BARRELS SHOWING  
TEMPORARY SOIL RETENTION SYSTEM LIMITS**

(Dimensions parallel to  $\phi$  FAP 781)

**NOTES**

- Existing structure details are based on the best available information from existing bridge plans.
- A cantilevered sheet piling design does not appear feasible and additional members or other retention systems may be necessary. The Contractor shall submit a temporary soil retention system design including plan details and calculations for review and acceptance by the Engineer.
- Limits of Rock Fill - Replacement are shown for culvert outside of the existing bridge. For culvert inside of the existing bridge, widen limits to the inside faces of the existing abutments.

**GENERAL NOTES**

- Reinforcement bars shall conform to the requirements of ASTM A 706 Gr 60.
- Layout of the slope protection system may be varied to suit ground conditions in the field as directed by the Engineer.
- For backfilling and embankment outside of the limits of Rock Fill - Replacement see Standard Specifications.
- Precast alternate is not allowed.
- Remove unsuitable soil beneath the footprint of the box culvert and two feet beyond the perimeter of the culvert and wingwalls as shown on Sheet No. 1. Replace with rock fill.
- The limits and quantities of Removal and Disposal of Unsuitable Material for Structures and Rock Fill - Replacement shown are based on the boring data and may be modified by the District Geotechnical and Field Engineers for variable subsurface conditions encountered in the field.

**TOTAL BILL OF MATERIAL**

ITEM	UNIT	QUANTITY
Removal and Disposal of Unsuitable Material for Structures	Cu. Yd.	515
Stone Riprap, Class A4	Sq. Yd.	257
Filter Fabric	Sq. Yd.	257
Removal of Existing Structures	Each	1
Reinforcement Bars	Pound	62,780
Bar Splicers	Each	188
Temporary Soil Retention System	Sq. Ft.	362
Name Plates	Each	1
Concrete Box Culverts	Cu. Yd.	284.0
Geotextile Retaining Wall	Sq. Ft.	148
Permanent Steel Sheet Piling	Sq. Ft.	402
Rock Fill - Replacement	Ton	875

See Roadway Plans for quantities of Temporary Concrete Barrier, Earth Excavation, and Porous Granular Embankment.

**ESCA**  
CONSULTANTS, INC.

DESIGNED BY:	ELH	03/10
DRAWN BY:	DWH/HAS	03/10
CHECKED BY:	ELH	06/10
APPROVED BY:	RDP	06/10

STATION 705+40  
BUILT BY  
STATE OF ILLINOIS  
F.A. RT. 781 SEC. 109B-1  
LOADING HS20-44  
STR. NO. 051-2008

**NAME PLATE**  
See Std. 515001

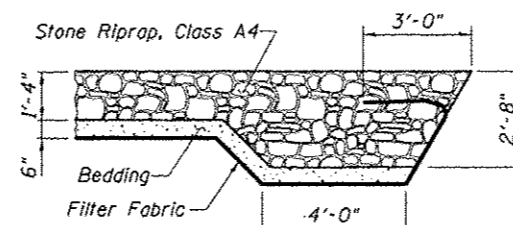

**SECTION A-A**

**GENERAL DATA**  
**STRUCTURE NO. 051-2008**

SHEET NO. 2 10 SHEETS	F.A.P. RTE. 781	SECTION 109B-1	COUNTY LAWRENCE	TOTAL SHEETS 34	SHEET NO. 16
	CONTRACT NO. 74105				
FED. ROAD DIST. NO. ILLINOIS FED. AID PROJECT					

STATE OF ILLINOIS  
DEPARTMENT OF TRANSPORTATION

**STAGE CONSTRUCTION NOTES**

1. Hatched areas indicate Removal of Existing Structures.
2. For details of Temporary Concrete Barrier, see Sht. No. 9 of 10.
3. Removal of existing bridge rail is included with Removal of Existing Structures.
4. All sections are looking South.
5. Horizontal dimensions are at right angles at  $\odot$  FAP 781.

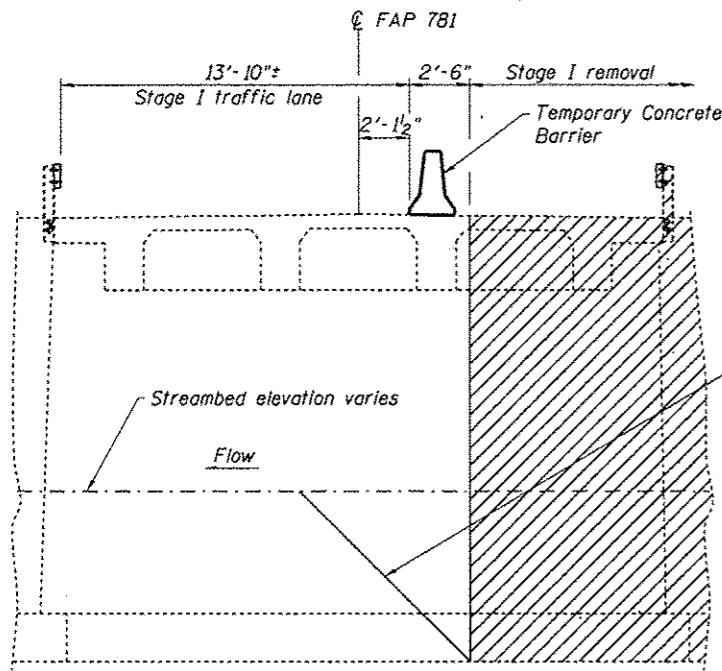

**STAGE I REMOVAL**

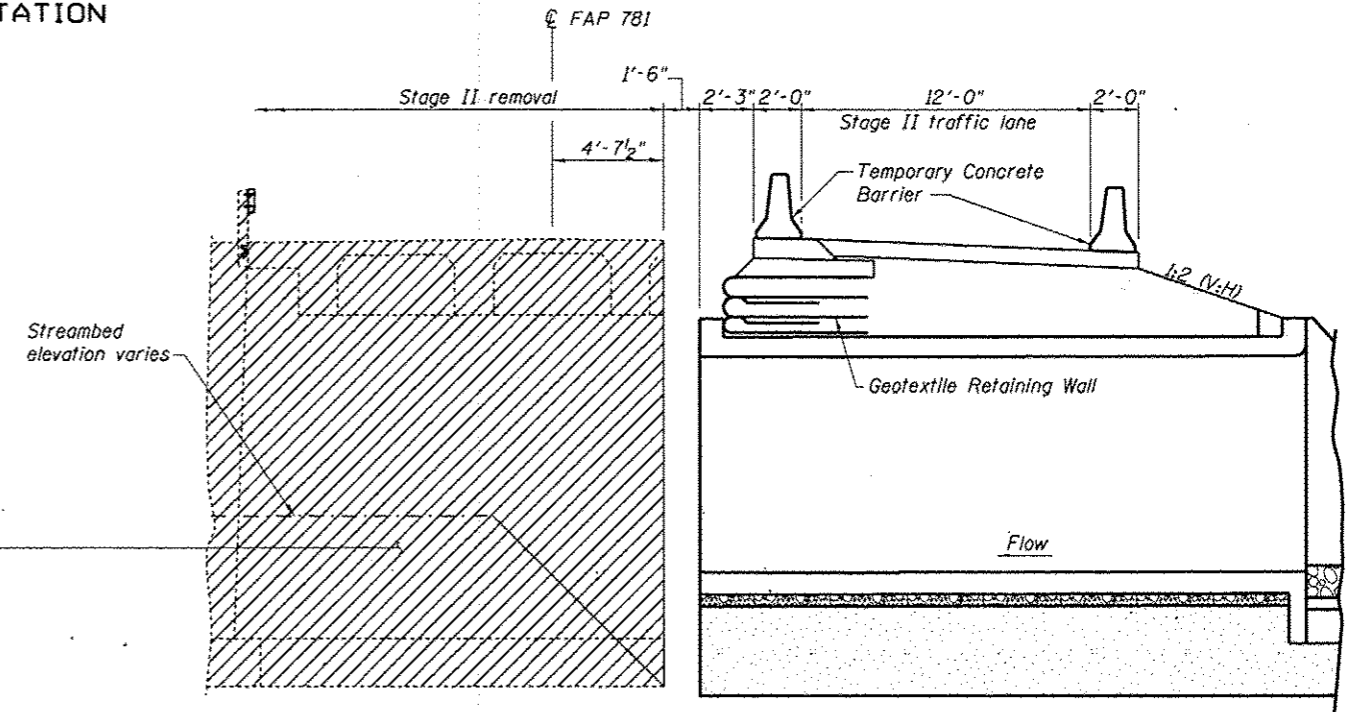

**STAGE II REMOVAL**

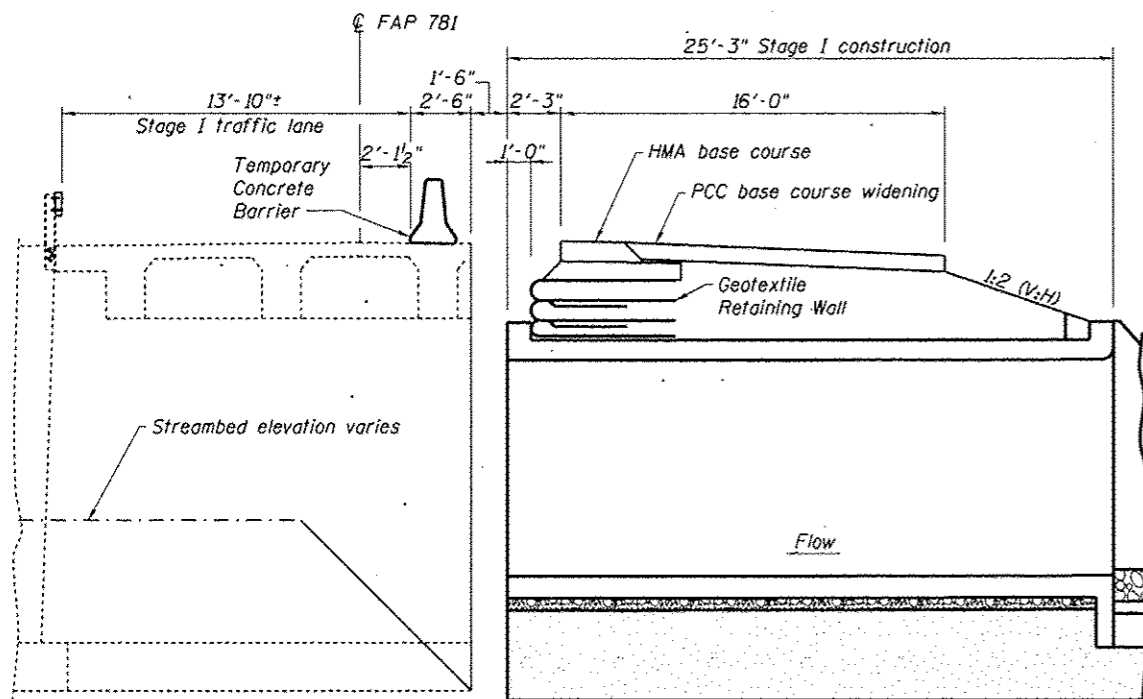

**STAGE I CONSTRUCTION**

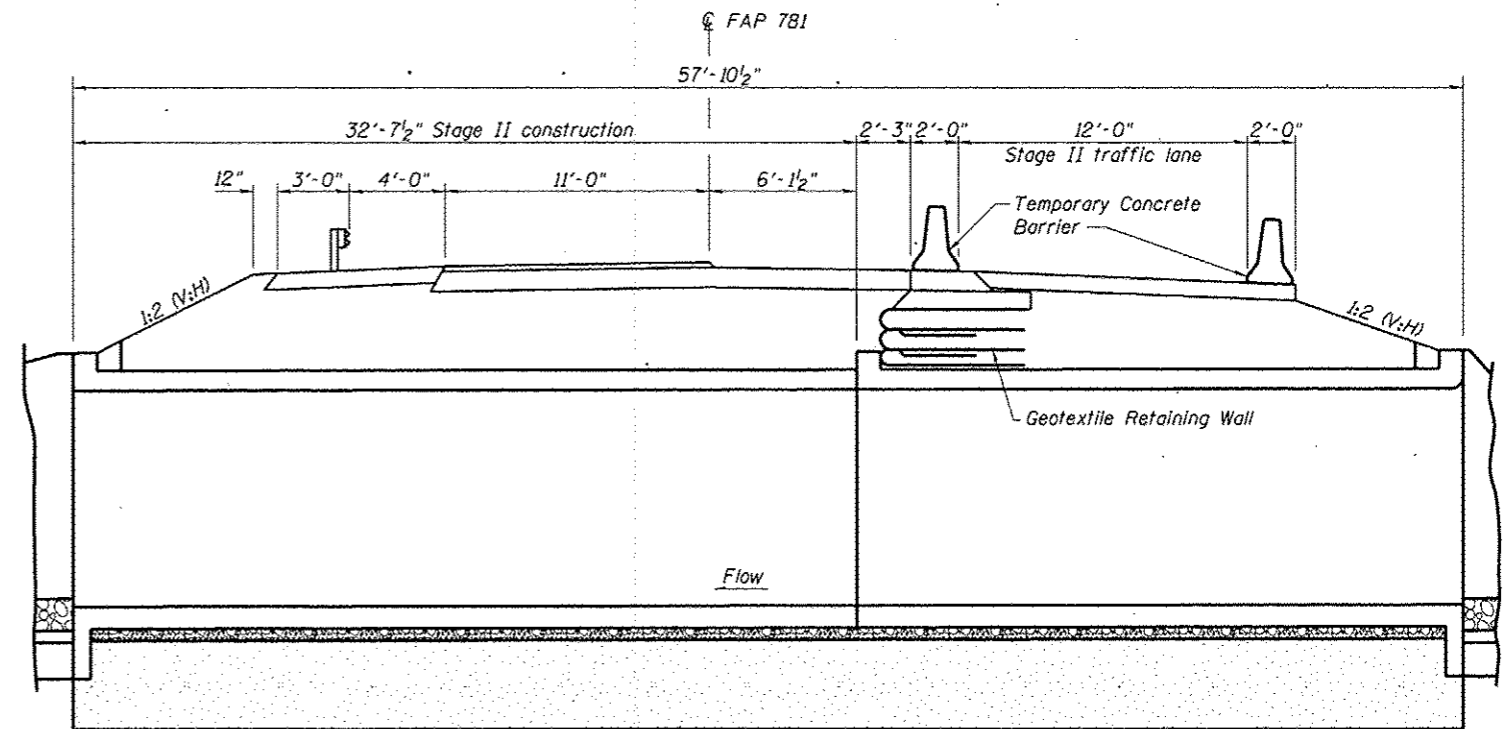

**STAGE II CONSTRUCTION**

**STAGE CONSTRUCTION DETAILS  
STRUCTURE NO. 051-2008**

**ESCA**  
CONSULTANTS, INC.

DESIGNED BY: ELH 03/10  
DRAWN BY: DWH/HAS 03/10  
CHECKED BY: ELH 06/11  
APPROVED BY: RDP 06/11

SHEET NO. 3 10 SHEETS	F.A.P. RTE.	SECTION	COUNTY	TOTAL SHEETS	SHEET NO.
	781	109B-1	LAWRENCE	34	17
CONTRACT NO. 74105					
FED. ROAD DIST. NO. ILLINOIS FED. AID PROJECT					

STATE OF ILLINOIS  
DEPARTMENT OF TRANSPORTATION

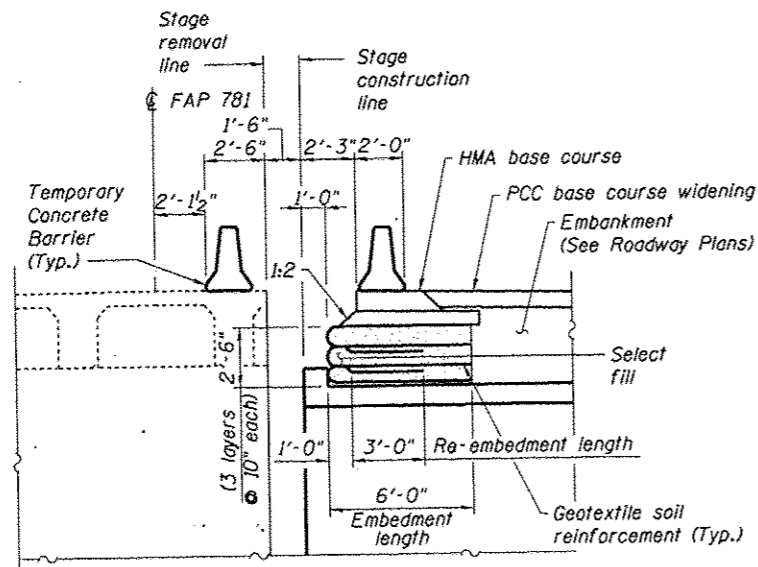

**TEMPORARY GEOTEXTILE WALL  
TYPICAL SECTION**  
(Horizontal dimensions at right angle to  $\text{\textcircled{C}}$  FAP 781)

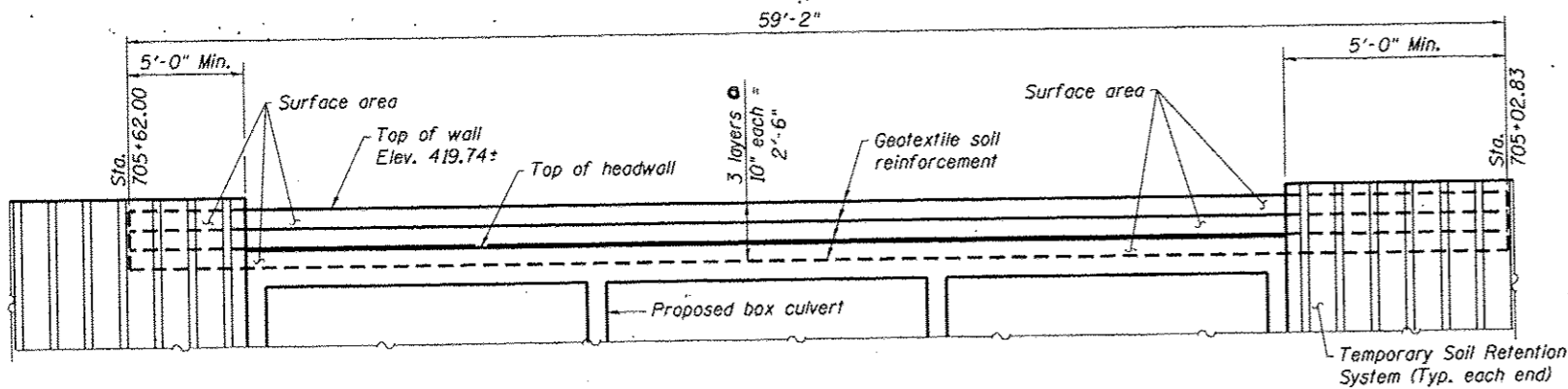

**TEMPORARY GEOTEXTILE WALL ELEVATION**  
(Looking West)  
(Horizontal dimensions parallel to  $\text{\textcircled{C}}$  FAP 781)

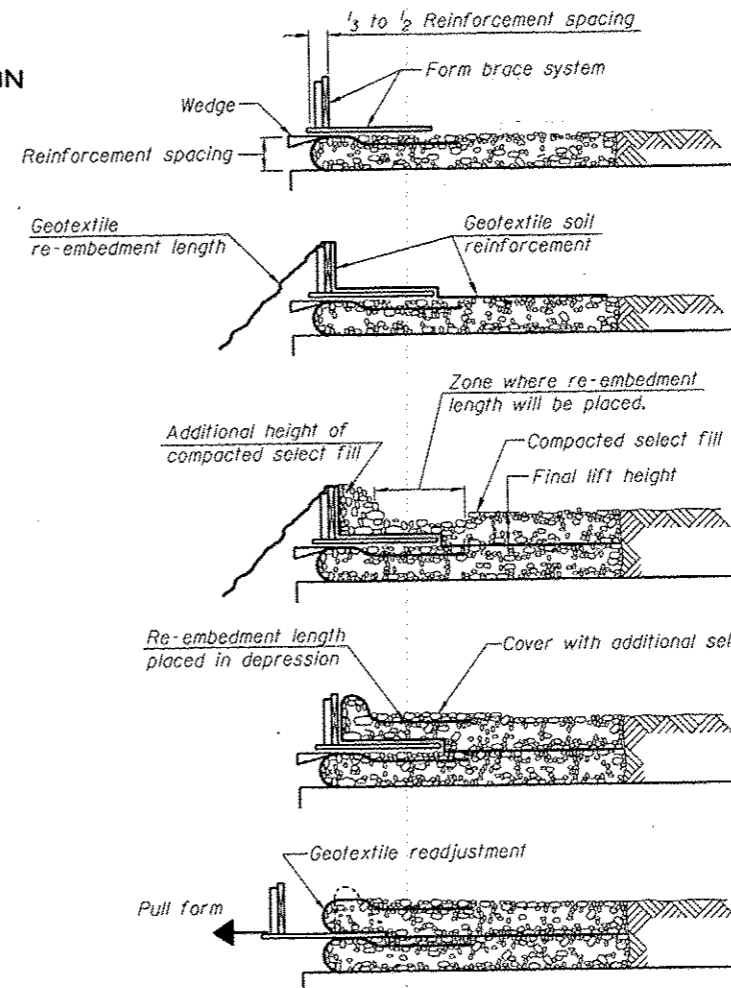

1. Place form brace system on completed reinforcement level; back from the finished fabric face a distance of  $\frac{1}{3}$  to  $\frac{1}{2}$  the geotextile reinforcement spacing.
2. Position fabric so that the required geotextile re-embedment length extends over the top of the form brace and the design reinforcement width is placed with no slack against the previous level.
3. Compact select fill material in lifts to final lift height, create ( $\pm 3''$ ) depression in zone where re-embedment length will be located and place additional height of compacted select fill against form brace.
4. Fold geotextile re-embedment length back over form brace into zone where depression was made in select fill and place additional select fill ( $\pm 3''$ ) to embed geotextile and bring to final lift height.
5. Pull form brace outward allowing geotextile face to slightly readjust to form tight round face level with plan reinforcement spacing.

**TEMPORARY GEOTEXTILE  
WALL CONSTRUCTION SEQUENCE**

Note:  
The geotextile soil reinforcement shall have a minimum allowable tensile strength ( $T_{min}$ ) of 25 lb./in. as determined by the procedure described in the Special Provision. The computations supporting the determination of ( $T_{min}$ ) shall be submitted to the engineer for approval.

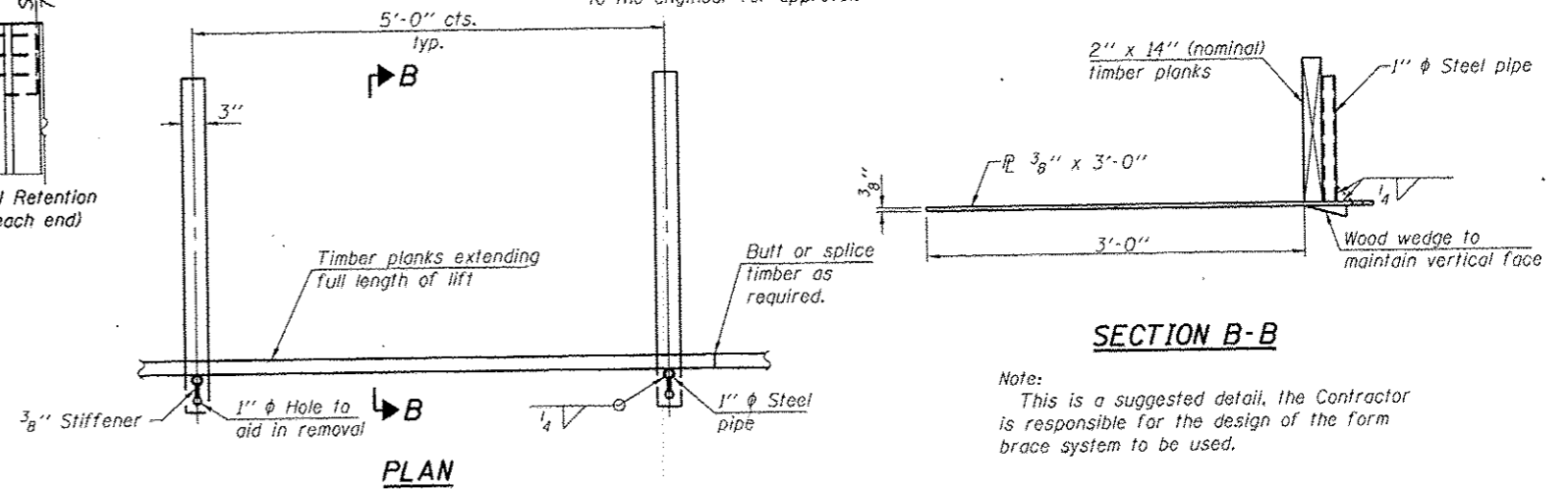

**TEMPORARY GEOTEXTILE  
FORM BRACE DETAIL**

**SECTION B-B**

Note:  
This is a suggested detail, the Contractor is responsible for the design of the form brace system to be used.

**STAGE CONSTRUCTION DETAILS  
STRUCTURE NO. 051-2008**

**ESCA**  
CONSULTANTS, INC.  
DESIGNED BY: ELH 03/10  
DRAWN BY: DWH/HAS 03/10  
CHECKED BY: ELH 06/11  
APPROVED BY: RDP 06/11

SHEET NO. 4 10 SHEETS	F.A.P. RTE. 781	SECTION 109B-1	COUNTY LAWRENCE	TOTAL SHEETS 34	SHEET NO. 18
	CONTRACT NO. 74105				
FED. ROAD DIST. NO.		ILLINOIS	FED. AID PROJECT		

STATE OF ILLINOIS  
DEPARTMENT OF TRANSPORTATION  
55'-10 1/2"

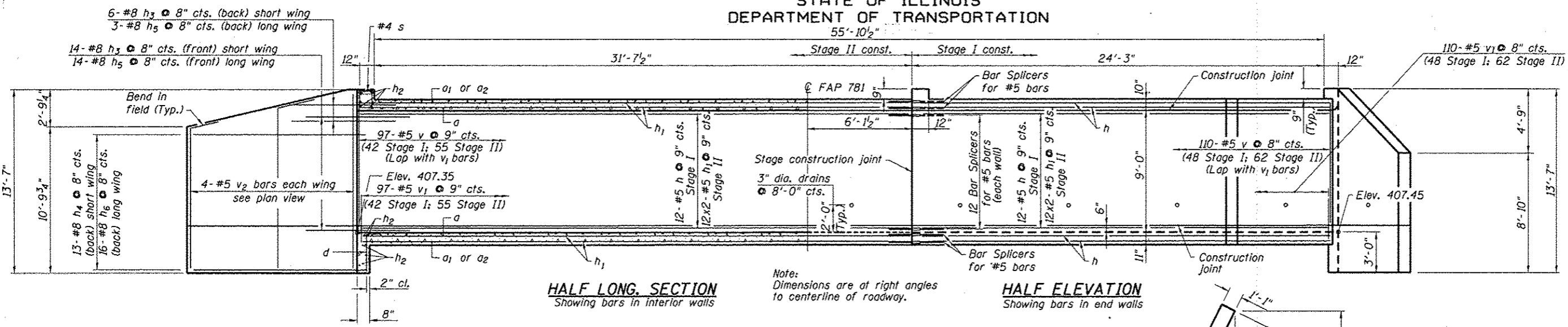

**HALF LONG SECTION**  
Showing bars in interior walls

Note:  
Dimensions are at right angles  
to centerline of roadway.

**HALF ELEVATION**  
Showing bars in end walls

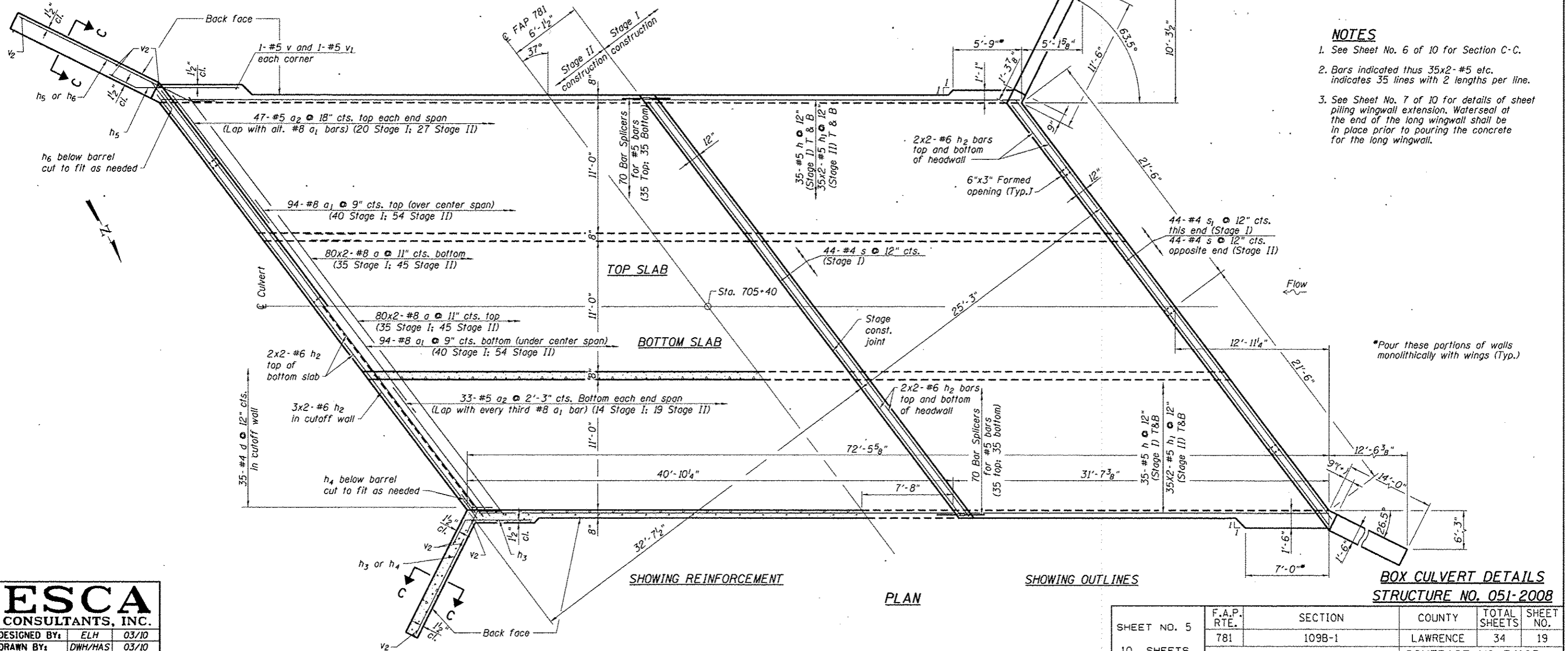

SHOWING REINFORCEMENT

PLAN

SHOWING OUTLINES

- NOTES**
1. See Sheet No. 6 of 10 for Section C-C.
  2. Bars indicated thus 35x2-#5 etc. indicates 35 lines with 2 lengths per line.
  3. See Sheet No. 7 of 10 for details of sheet piling wingwall extension. Waterseal at the end of the long wingwall shall be in place prior to pouring the concrete for the long wingwall.

**BOX CULVERT DETAILS**  
STRUCTURE NO. 051-2008

**ESCA**  
CONSULTANTS, INC.

DESIGNED BY:	ELH	03/10
DRAWN BY:	DWH/HAS	03/10
CHECKED BY:	ELH	06/10
APPROVED BY:	RDP	06/10

SHEET NO. 5 10 SHEETS	F.A.P. RTE.	SECTION	COUNTY	TOTAL SHEETS	SHEET NO.
	781	109B-1	LAWRENCE	34	19
CONTRACT NO. 74105					
FED. ROAD DIST. NO. ILLINOIS FED. AID PROJECT					

STATE OF ILLINOIS  
DEPARTMENT OF TRANSPORTATION

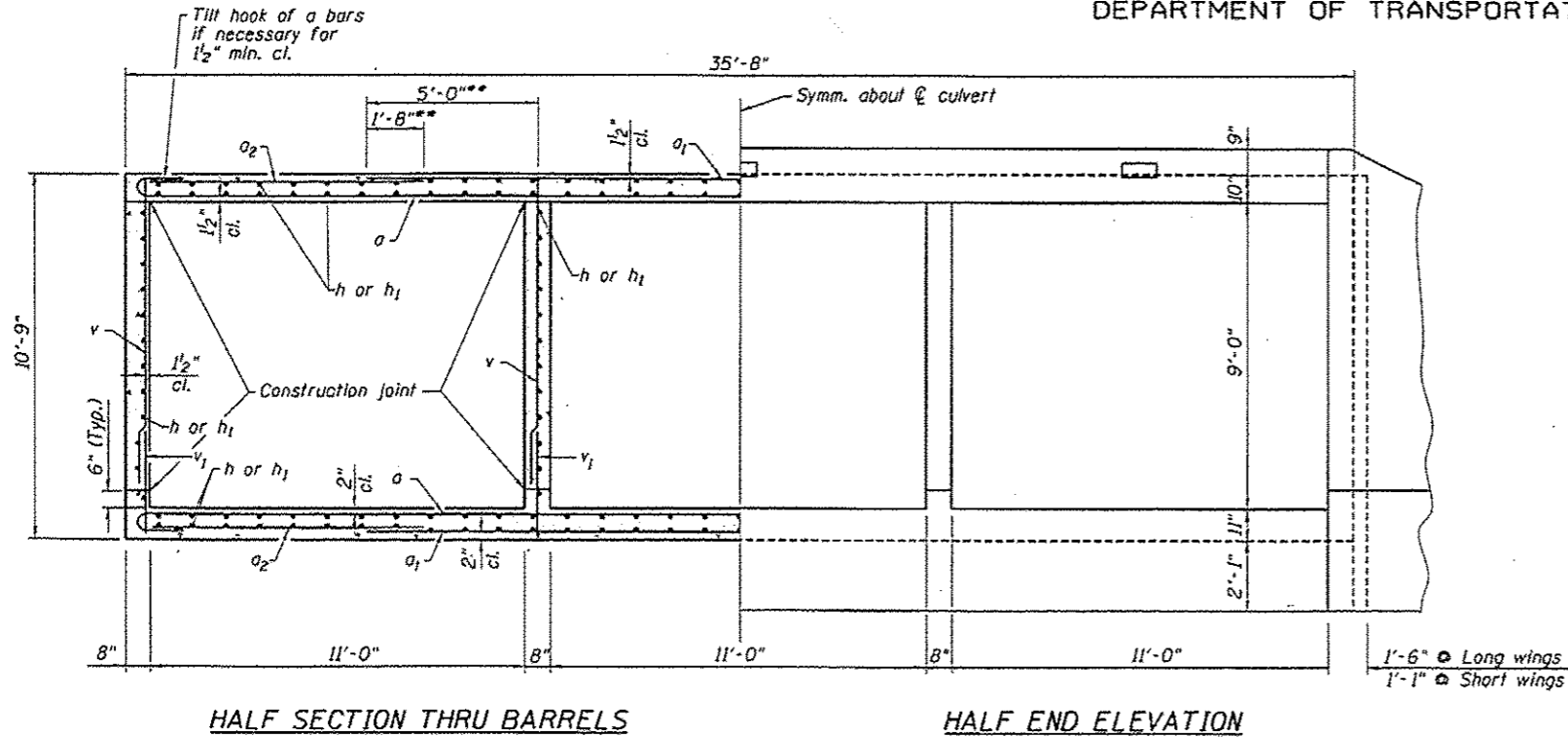

\*\* Dimensions noted thus are parallel to  $\text{\textcircled{C}}$  Roadway

Natch formed by rough finished board attached to and removed with formwork, each interior wall (do not chamfer).

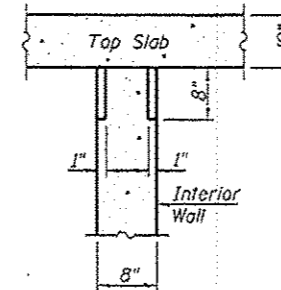
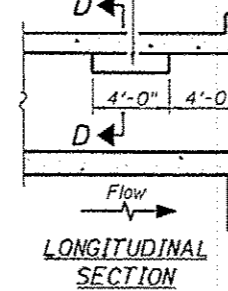

SECTION D-D  
PHOEBE NESTING  
SITE DETAILS  
(Downstream End Only)

BILL OF MATERIAL

Bar	No.	Size	Length	Shape
a	320	#8	25'-4"	C
a1	188	#8	24'-8"	—
a2	160	#5	11'-6"	—
d	70	#4	4'-6"	—
h	188	#5	31'-2"	—
h1	376	#5	21'-1"	—
h2	44	#6	23'-11"	—
h3	40	#8	8'-0"	—
h4	26	#8	14'-8"	—
h5	34	#8	8'-0"	—
h6	32	#8	19'-4"	—
s	88	#4	4'-10"	—
s1	44	#4	4'-8"	—
v	418	#5	9'-0"	—
v1	418	#5	3'-0"	—
v2	16	#5	13'-2"	—
Concrete Box Culverts			Cu. Yd.	275.5
Reinforcement Bars			Pound	62,240

MIN. BAR LAP

- #5 ----- 1'-8"
- #6 ----- 2'-0"
- #8 ----- 4'-6"

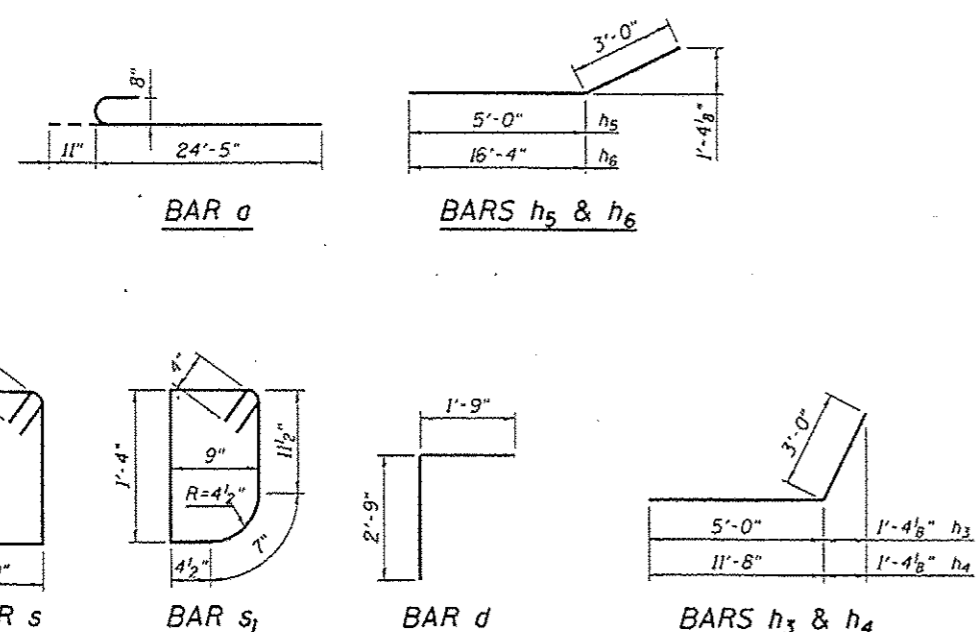

\*\*\* Coarse aggregate full length of both headwalls. To be placed by Grading Contractor. Cast included with Concrete Box Culverts.

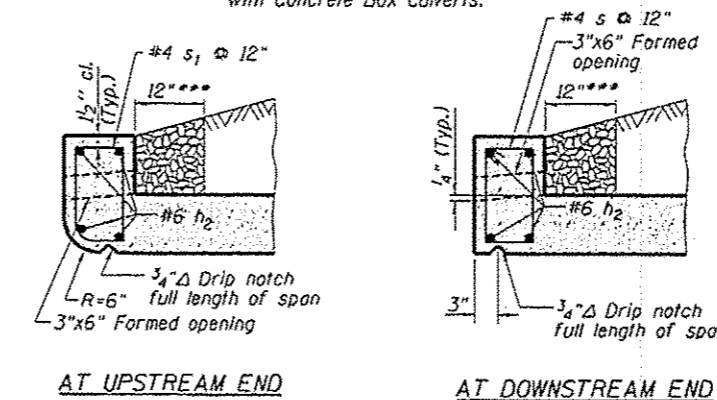

DRAIN DETAILS

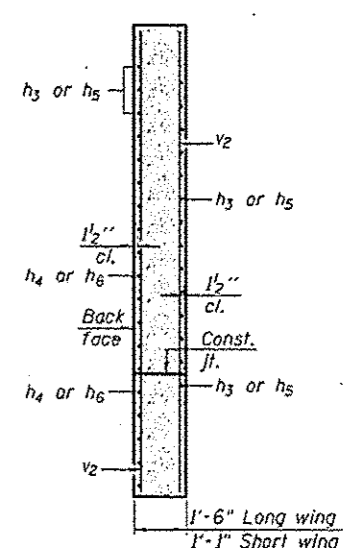

SECTION C-C  
(Bars shown are in long wing)

**ESCA**  
CONSULTANTS, INC.

DESIGNED BY:	ELH	03/10
DRAWN BY:	DWH/HAS	03/10
CHECKED BY:	ELH	04/10
APPROVED BY:	RDP	04/10

BOX CULVERT DETAILS  
STRUCTURE NO. 051-2008

SHEET NO. 6 10 SHEETS	F.A.P. RTE.	SECTION	COUNTY	TOTAL SHEETS	SHEET NO.
	781	109B-1	LAWRENCE	34	20
			CONTRACT NO. 74105		
FED. ROAD DIST. NO. [ILLINOIS] FED. AID PROJECT					

STATE OF ILLINOIS  
DEPARTMENT OF TRANSPORTATION

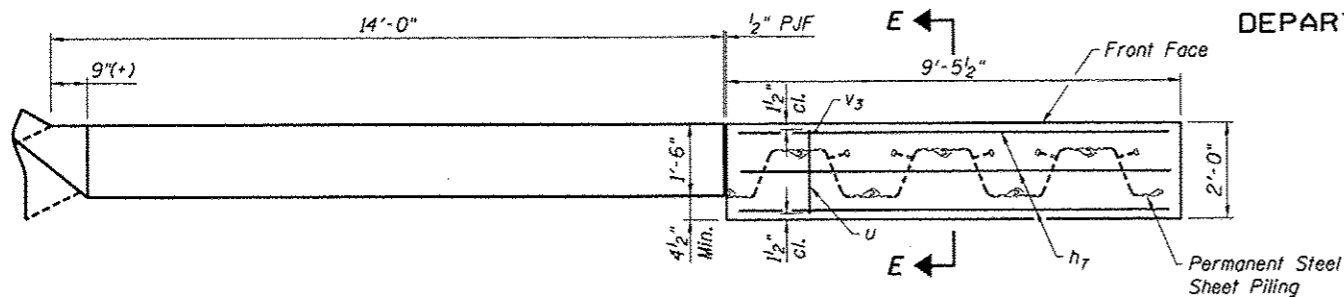

LONG WING PLAN

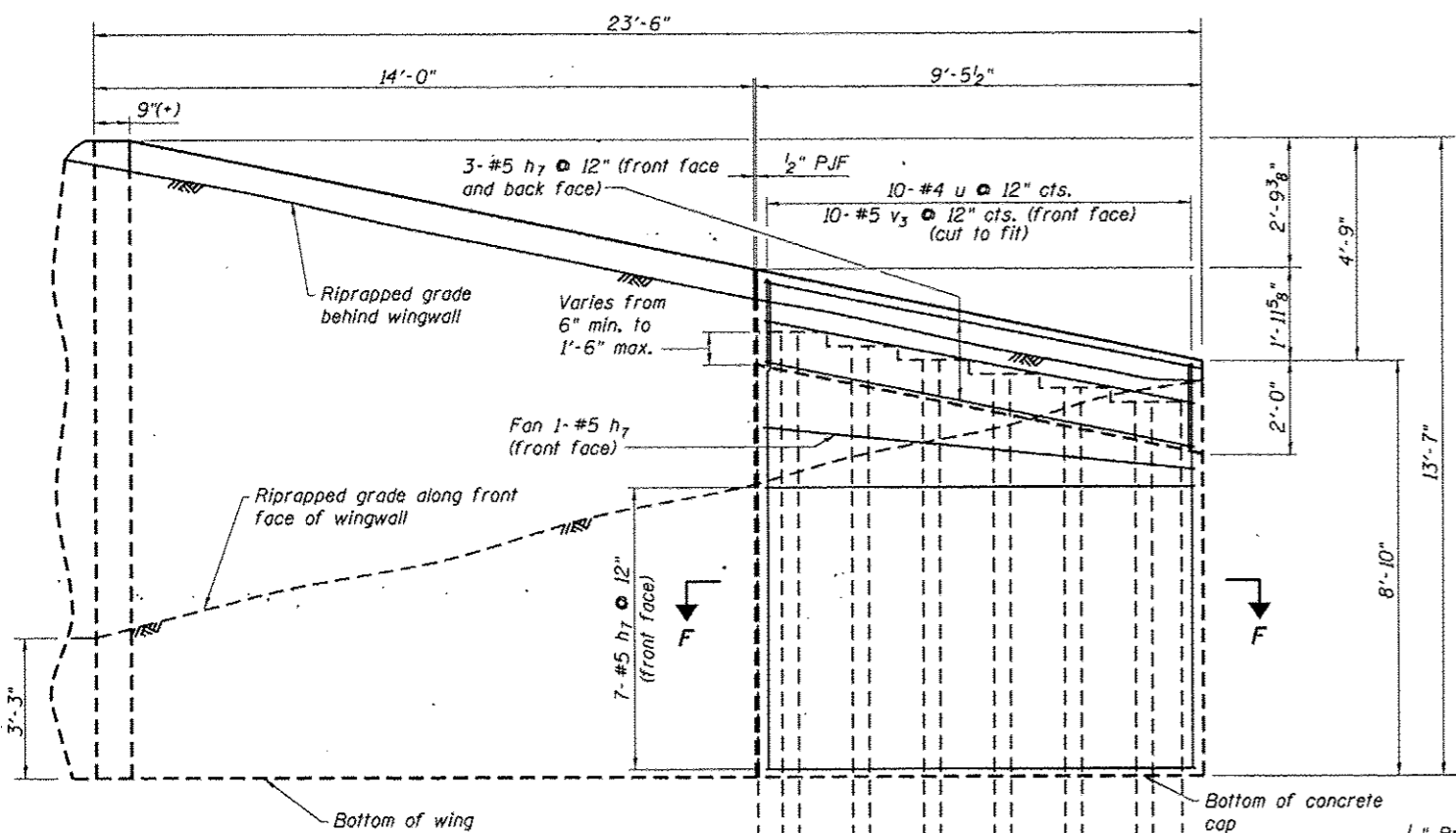

LONG WING ELEVATION  
(Looking at Back Face)

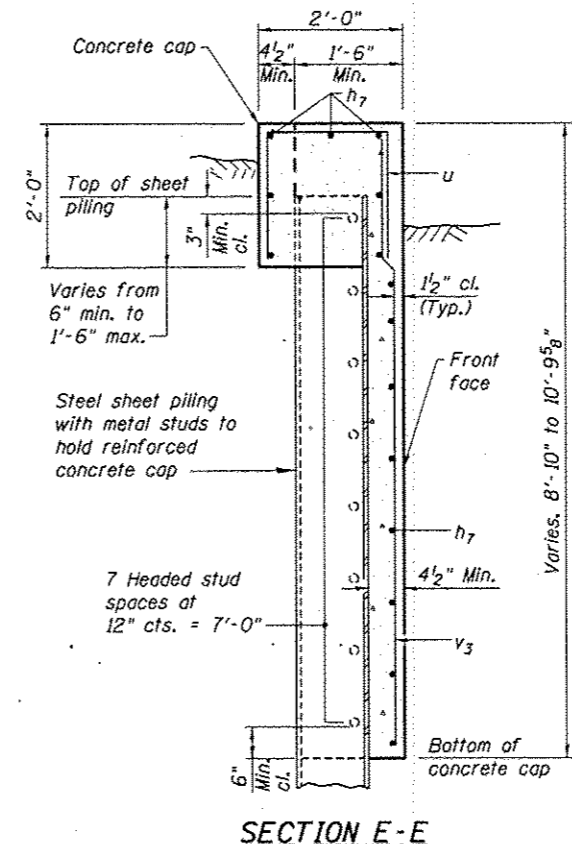

SECTION E-E

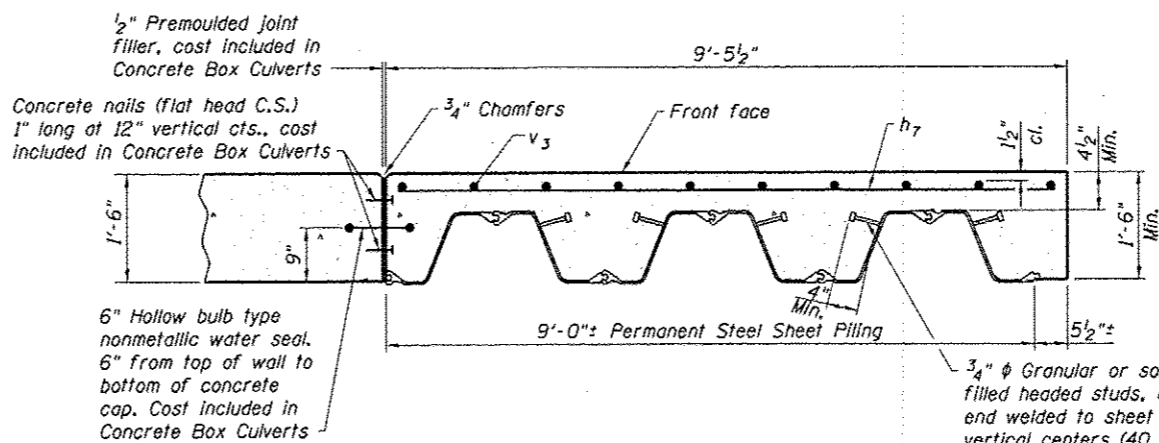

SECTION F-F

**BILL OF MATERIAL**

Bar	No.	Size	Length	Shape
h7	28	#5	9'-2"	—
u	20	#4	5'-3"	□
v3	10	#5	18'-11"	—
			Concrete Box Culverts	Cu. Yd. 8.5
			Reinforcement Bars	Pound 540
			Permanent Steel Sheet Piling	Sq. Ft. 402

- NOTES**
- The quantity of concrete for the sheet piling cap is included in Concrete Box Culverts.
  - The cost of supplying and installing the shear studs is included in Permanent Steel Sheet Piling.

**CONSTRUCTION SEQUENCE**

- Excavate site for box culvert wingwall and steel sheet piling wall.
- Backfill with rock fill as shown on the plans.
- Construct box culvert wingwall and include water seal in concrete pour.
- Install 1/2" P.J.F. with concrete nails.
- Install Permanent Steel Sheet Piling.
- Backfill behind box culvert wingwall and Permanent Steel Sheet Piling.
- Construct concrete cap.
- Complete backfill in front of and behind wall.
- Install stone riprap around wall.

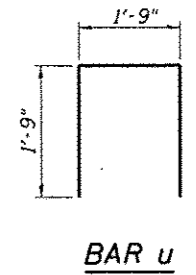

BAR u

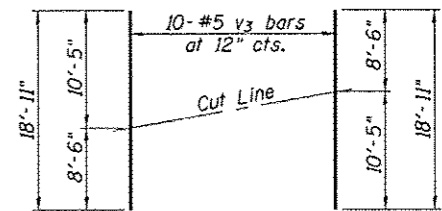

BAR v3

**FIELD CUTTING DIAGRAM**

Order v3 full length. Cut as shown and use remainder of bars in opposite wall.

**STEEL SHEET PILING WALL DETAILS  
STRUCTURE NO. 051-2008**

SHEET NO. 7 10 SHEETS	F.A.P. RTE.	SECTION	COUNTY	TOTAL SHEETS	SHEET NO.
	781	109B-1	LAWRENCE	34	21
CONTRACT NO. 74105					
FED. ROAD DIST. NO.		ILLINOIS	FED. AID PROJECT		

**ESCA**  
CONSULTANTS, INC.

DESIGNED BY:	ELH	03/10
DRAWN BY:	DWH/HAS	03/10
CHECKED BY:	ELH	06/10
APPROVED BY:	RDP	06/10

Elev. 391.18 SE wall  
Elev. 391.28 NW wall

Permanent Steel Sheet Piling  
minimum effective section  
modulus = 25 in.<sup>3</sup>/ft.  
Minimum tip elevation  
of sheet piling

STATE OF ILLINOIS  
DEPARTMENT OF TRANSPORTATION

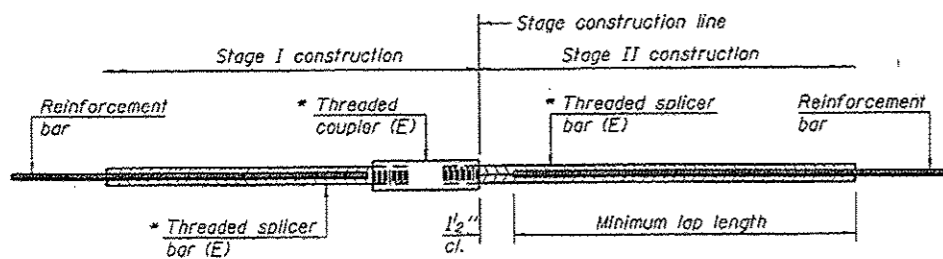

STANDARD BAR SPLICER ASSEMBLY

Minimum Lap Lengths				
Bar size to be spliced	Table 1	Table 2	Table 3	Table 4
3, 4	1'-5"	1'-11"	2'-1"	2'-4"
5	1'-9"	2'-5"	2'-7"	2'-11"
6	2'-1"	2'-11"	3'-1"	3'-6"
7	2'-9"	3'-10"	4'-2"	4'-8"
8	3'-8"	5'-1"	5'-5"	6'-2"
9	4'-7"	6'-5"	6'-10"	7'-9"

Table 1: Black bar, 0.8 Class C  
Table 2: Black bar, Top bar lap, 0.8 Class C  
Table 3: Epoxy bar, 0.8 Class C  
Table 4: Epoxy bar, Top bar lap, 0.8 Class C

Threaded splicer bar length = min. lap length + 1/2" + thread length

\* Epoxy not required on Bar Splicer Assembly components used in conjunction with black bars.

Location	Bar size	No. assemblies required	Table for minimum lap length
Bottom slab	#5	70	1
Top slab	#5	70	1
Walls	#5	48	1

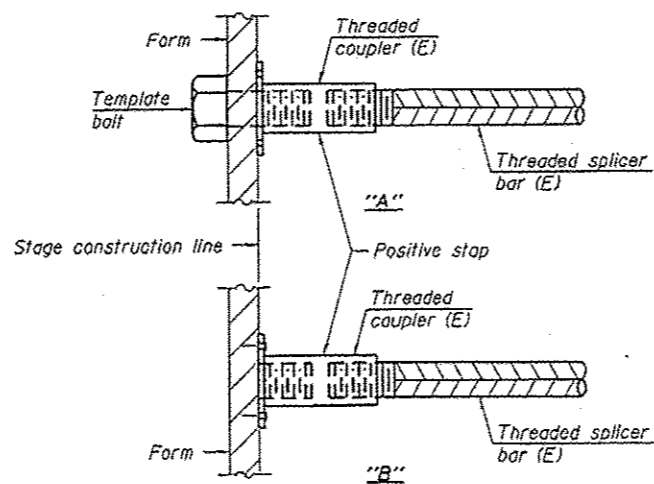

INSTALLATION AND SETTING METHODS

"A": Set bar splicer assembly by means of a template bolt.  
"B": Set bar splicer assembly by nailing to wood forms or cementing to steel forms.  
(E): Indicates epoxy coating.

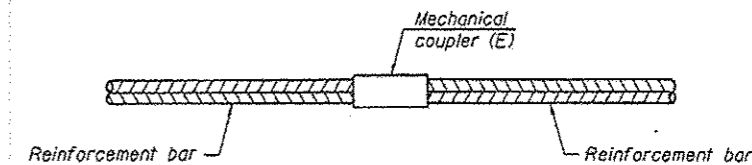

STANDARD MECHANICAL SPLICER

Location	Bar size	No. assemblies required
NA		

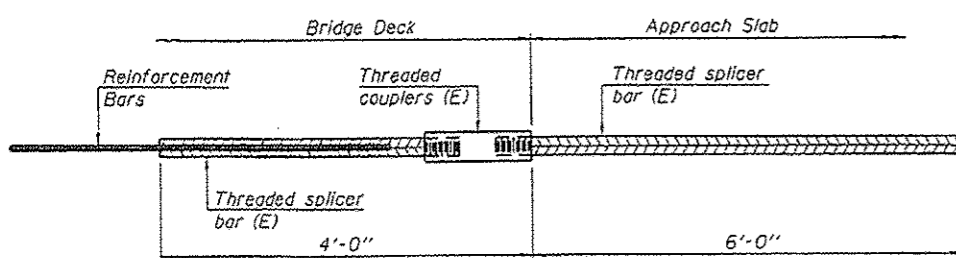

BAR SPLICER ASSEMBLY FOR #5 BAR ON INTEGRAL OR SEMI-INTEGRAL ABUTMENTS

No. required = 0

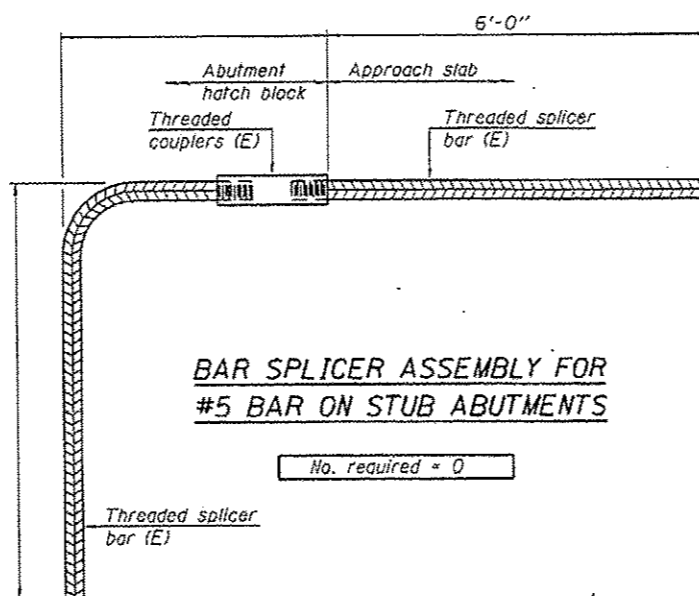

BAR SPLICER ASSEMBLY FOR #5 BAR ON STUB ABUTMENTS

No. required = 0

NOTES

Splicer bars shall be deformed with threaded ends and have a minimum 60 ksi yield strength.  
All reinforcement shall be lapped and tied to the splicer bars.  
Bar splicer assemblies shall be epoxy coated according to the requirements for reinforcement bars. See Section 508 of the Standard Specifications.

See approved list of bar splicer assemblies and mechanical splicers for alternatives.

BAR SPLICER ASSEMBLY DETAILS  
STRUCTURE NO. 051-2008

**ESCA**  
CONSULTANTS, INC.

DESIGNED BY: ELH 03/10  
DRAWN BY: DWH 03/10  
CHECKED BY: ELH 03/10  
APPROVED BY: ROP 03/10

BSD-1

11-1-09

SHEET NO.	F.A.P. RTE.	SECTION	COUNTY	TOTAL SHEETS	SHEET NO.
8	781	109B-1	LAWRENCE	34	22
10 SHEETS					
CONTRACT NO. 74105					
FED. ROAD DIST. NO. ILLINOIS FED. AID PROJECT					

STATE OF ILLINOIS  
DEPARTMENT OF TRANSPORTATION

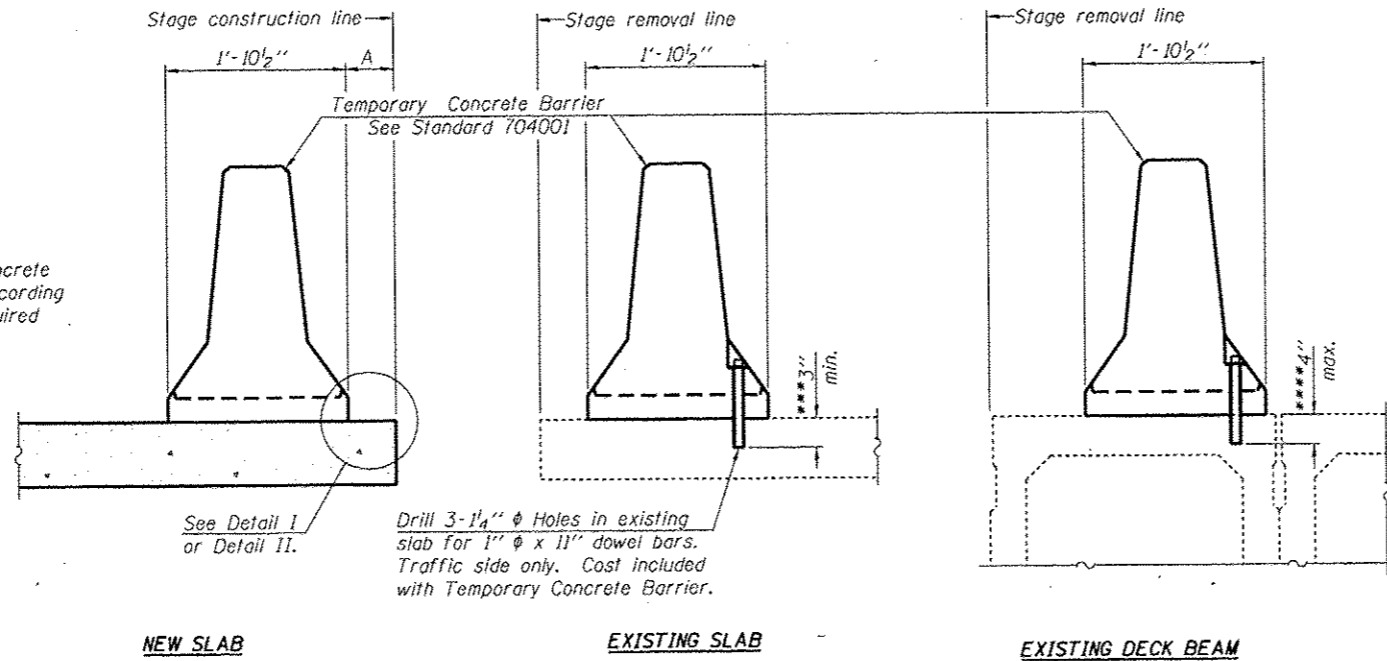

When "A" is 3'-6" or less, the temporary concrete barrier shall be anchored to the new slab according to Detail I or Detail II. No anchorage is required when "A" is greater than 3'-6".

NEW SLAB

EXISTING SLAB

EXISTING DECK BEAM

SECTIONS THRU SLAB OR DECK BEAM

**NOTES**

Detail I - With Bar Splicer or Couplers: Connect one (1) 1"x7"x10" steel  $\bar{P}$  to the top layer of couplers with 2-5/8"  $\phi$  bolts screwed to coupler at approximate  $\bar{C}$  of each barrier panel.

Detail II - With Extended Reinforcement Bars: Connect one (1) 1"x7"x10" steel  $\bar{P}$  to the concrete slab or concrete wearing surface with 2-5/8"  $\phi$  Expansion Anchors or cast in place inserts spaced between the top layer of reinforcement at approximate  $\bar{C}$  of each barrier panel.

Cost of anchorage is included with Temporary Concrete Barrier. The 1" x 7" x 10" plate shall not be removed until stage II construction forms and all reinforcement bars are in place and the concrete is ready to be placed.

\*\*\* Dimension shown is minimum required embedment into concrete. If hot-mix asphalt wearing surface is present, minimum embedment shall be in addition to wearing surface depth.

\*\*\*\* If existing deck beam is to remain in place after stage construction, embedment shall only be into wearing surface and not into existing deck beam concrete.

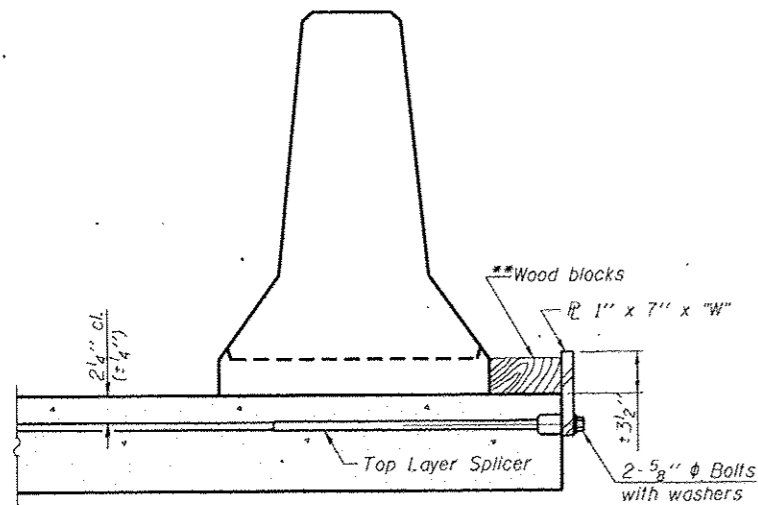

DETAIL I

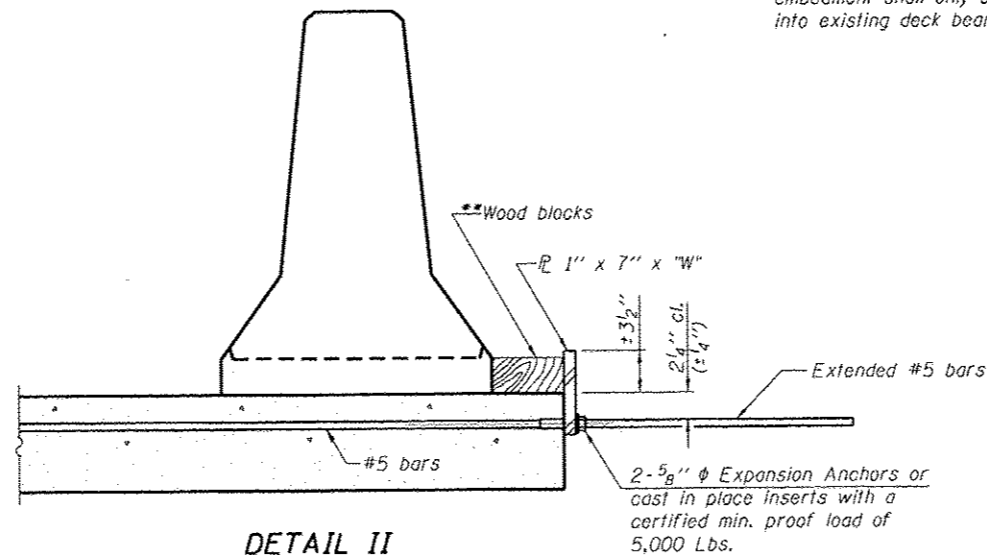

DETAIL II

\*\* Wood blocks may be omitted when required to provide minimum stage traffic lane width. When the wood blocks are omitted, the concrete barrier shall be in direct contact with the steel retainer plate.

"W" = Top bars spacing + 4"

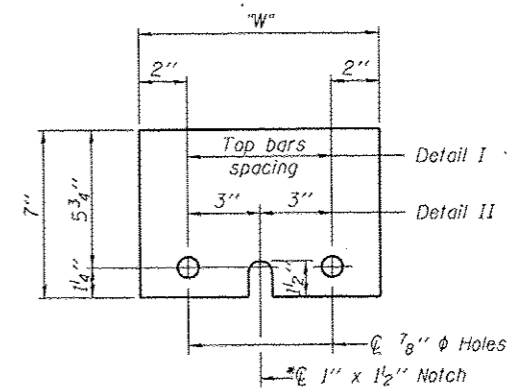

STEEL RETAINER  $\bar{P}$  1" x 7" x 10"

\* Required only with Detail II

TEMPORARY CONCRETE BARRIER  
FOR STAGE CONSTRUCTION  
STRUCTURE NO. 051-2008

**ESCA**  
CONSULTANTS, INC.

DESIGNED BY:	ELH	03/10
DRAWN BY:	DWH	03/10
CHECKED BY:	ELH	03/10
APPROVED BY:	RDP	03/10

R-27

11-1-09

SHEET NO. 9	F.A.P. RTE.	SECTION	COUNTY	TOTAL SHEETS	SHEET NO.
	781	109B-1	LAWRENCE	34	23
10 SHEETS	CONTRACT NO. 74105				
FED. ROAD DIST. NO.		ILLINOIS	FED. AID PROJECT		



STATE OF ILLINOIS  
DEPARTMENT OF TRANSPORTATION

**Illinois Department of Transportation**  
SOIL BORING LOG  
Page 1 of 3  
Date 10/15/08

ROUTE FAP 781 (L 33) DESCRIPTION Un-Name'd Stream LOGGED BY E. Sandtschaber

SECTION 109B-1 LOCATION NW 1/4, SEC. 33, TWP. 5 N, RND. 10 W, 3 PM

COUNTY Lawrence DRILLING METHOD Hollow stem auger & split spoon HAMMER TYPE Auto 140#

STRUCT. NO. 051-0035 Station 705+40 Surface Water Elev. 436.50 ft Stream Bed Elev. 427.73 ft

BORING NO. 1-N Abut Station 704+00 Groundwater Elev. 421.8 ft First Encounter Upon Completion 427.3 ft After 24 Hrs. 427.3 ft

Ground Surface Elev. 421.27 ft (B) (F) (M) (%) (N) (R) (S) (T) (U) (V) (%)

1 Medium wet brown fine grained SAND 2% passing #200 sieve

2 Soft to medium damp brown CLAY LOAM

3 Medium wet brown coarse grained SAND of many small Gravel. 0.2% passing #200 sieve

4 Soft damp brown SANDY CLAY

5 Soft to medium damp brown CLAY of some sand

6 Medium damp brown SANDY CLAY LOAM

7 Soft to medium damp brown SANDY LOAM

8 Very dense med. gray CLAY SHALE

The Unconfined Compressive Strength (UCS) Failure Mode is indicated by (B-Bulge, S-Shear, P-Penetrometer)  
The SPT (N value) is the sum of the last two blow values in each sampling zone (AASHTO T206)  
BBS, from 137 (Rev. 8-99)

**Illinois Department of Transportation**  
SOIL BORING LOG  
Page 2 of 3  
Date 10/15/08

ROUTE FAP 781 (L 33) DESCRIPTION Un-Name'd Stream LOGGED BY E. Sandtschaber

SECTION 109B-1 LOCATION NW 1/4, SEC. 33, TWP. 5 N, RND. 10 W, 3 PM

COUNTY Lawrence DRILLING METHOD Hollow stem auger & split spoon HAMMER TYPE Auto 140#

STRUCT. NO. 051-0035 Station 705+40 Surface Water Elev. 436.50 ft Stream Bed Elev. 427.73 ft

BORING NO. 1-N Abut Station 704+00 Groundwater Elev. 421.8 ft First Encounter Upon Completion 427.3 ft After 24 Hrs. 427.3 ft

Ground Surface Elev. 421.27 ft (B) (F) (M) (%) (N) (R) (S) (T) (U) (V) (%)

1 Medium wet brown fine grained SAND 2% passing #200 sieve

2 Soft to medium damp brown CLAY LOAM

3 Medium wet brown coarse grained SAND of many small Gravel. 0.2% passing #200 sieve

4 Soft damp brown SANDY CLAY

5 Soft to medium damp brown CLAY of some sand

6 Medium damp brown SANDY CLAY LOAM

7 Soft to medium damp brown SANDY LOAM

8 Very dense med. gray CLAY SHALE

The Unconfined Compressive Strength (UCS) Failure Mode is indicated by (B-Bulge, S-Shear, P-Penetrometer)  
The SPT (N value) is the sum of the last two blow values in each sampling zone (AASHTO T206)  
BBS, from 137 (Rev. 8-99)

**Illinois Department of Transportation**  
ROCK CORE LOG  
Page 2 of 3  
Date 10/15/08

ROUTE FAP 781 (L 33) DESCRIPTION Un-Name'd Stream LOGGED BY E. Sandtschaber

SECTION 109B-1 LOCATION NW 1/4, SEC. 33, TWP. 5 N, RND. 10 W, 3 PM

COUNTY Lawrence CORING METHOD Rotary, surface diameter bit

STRUCT. NO. 051-0035 Station 705+40 CORING BARREL TYPE & SIZE NW, corr. dia. bit 405.0mm

BORING NO. 1-N Abut Station 704+00 Core Diameter 2.00 in Top of Rock Elev. 341.77 ft Begin Core Elev. 341.67 ft

Ground Surface Elev. 421.27 ft (B) (F) (M) (%) (N) (R) (S) (T) (U) (V) (%)

Rock core R1C1 from 81.7' to 82.3' depth  $Q_u = 948$  lbf

Rock core R1C2 from 85.6' to 87.1' depth  $Q_u = 440$  lbf

Benchmark: BM 512 chiseled square on top of NE wingwall of existing structure = 421.11', provided by Program Development

Color pictures of the cores Available on request  
Cores will be stored for examination until 10/31/2009  
The "Strength" column represents the uniaxial compressive strength of the core sample (ASTM D-2938)  
BBS, from 139 (Rev. 8-99)

**Illinois Department of Transportation**  
SOIL BORING LOG  
Page 1 of 3  
Date 10/15/08

ROUTE FAP 781 (L 33) DESCRIPTION Un-Name'd Stream LOGGED BY E. Sandtschaber

SECTION 109B-1 LOCATION NW 1/4, SEC. 33, TWP. 5 N, RND. 10 W, 3 PM

COUNTY Lawrence DRILLING METHOD Hollow stem auger & split spoon HAMMER TYPE Auto 140#

STRUCT. NO. 051-0035 Station 705+40 Surface Water Elev. 436.50 ft Stream Bed Elev. 427.73 ft

BORING NO. 2-N Abut Station 705+00 Groundwater Elev. 421.8 ft First Encounter Upon Completion 427.3 ft After 24 Hrs. 427.3 ft

Ground Surface Elev. 421.27 ft (B) (F) (M) (%) (N) (R) (S) (T) (U) (V) (%)

1 Medium wet brown fine grained SAND 2% passing #200 sieve

2 Soft damp gray sandy CLAY

3 Soft to medium damp brown CLAY

4 Soft damp brown medium sand CLAY

5 Very soft very damp brown SANDY LOAM with some small Gravel

6 Soft to medium damp brown SANDY LOAM

7 Soft to medium damp brown SANDY LOAM

8 Very dense med. gray CLAY

The Unconfined Compressive Strength (UCS) Failure Mode is indicated by (B-Bulge, S-Shear, P-Penetrometer)  
The SPT (N value) is the sum of the last two blow values in each sampling zone (AASHTO T206)  
BBS, from 137 (Rev. 8-99)

**Illinois Department of Transportation**  
SOIL BORING LOG  
Page 2 of 3  
Date 10/15/08

ROUTE FAP 781 (L 33) DESCRIPTION Un-Name'd Stream LOGGED BY E. Sandtschaber

SECTION 109B-1 LOCATION NW 1/4, SEC. 33, TWP. 5 N, RND. 10 W, 3 PM

COUNTY Lawrence DRILLING METHOD Hollow stem auger & split spoon HAMMER TYPE Auto 140#

STRUCT. NO. 051-0035 Station 705+40 Surface Water Elev. 436.50 ft Stream Bed Elev. 427.73 ft

BORING NO. 2-N Abut Station 705+00 Groundwater Elev. 421.8 ft First Encounter Upon Completion 427.3 ft After 24 Hrs. 427.3 ft

Ground Surface Elev. 421.27 ft (B) (F) (M) (%) (N) (R) (S) (T) (U) (V) (%)

1 Medium wet brown fine grained SAND 2% passing #200 sieve with some Gravel

2 Soft damp gray sandy CLAY

3 Soft to medium damp brown CLAY

4 Soft damp brown medium sand CLAY

5 Very soft very damp brown SANDY LOAM with some small Gravel

6 Soft to medium damp brown SANDY LOAM

7 Soft to medium damp brown SANDY LOAM

8 Very dense med. gray CLAY

The Unconfined Compressive Strength (UCS) Failure Mode is indicated by (B-Bulge, S-Shear, P-Penetrometer)  
The SPT (N value) is the sum of the last two blow values in each sampling zone (AASHTO T206)  
BBS, from 137 (Rev. 8-99)

**Illinois Department of Transportation**  
SOIL BORING LOG  
Page 3 of 3  
Date 10/15/08

ROUTE FAP 781 (L 33) DESCRIPTION Un-Name'd Stream LOGGED BY E. Sandtschaber

SECTION 109B-1 LOCATION NW 1/4, SEC. 33, TWP. 5 N, RND. 10 W, 3 PM

COUNTY Lawrence DRILLING METHOD Hollow stem auger & split spoon HAMMER TYPE Auto 140#

STRUCT. NO. 051-0035 Station 705+40 Surface Water Elev. 436.50 ft Stream Bed Elev. 427.73 ft

BORING NO. 2-N Abut Station 705+00 Groundwater Elev. 421.8 ft First Encounter Upon Completion 427.3 ft After 24 Hrs. 427.3 ft

Ground Surface Elev. 421.27 ft (B) (F) (M) (%) (N) (R) (S) (T) (U) (V) (%)

1 Medium wet brown fine grained SAND 2% passing #200 sieve

2 Soft damp gray sandy CLAY

3 Soft to medium damp brown CLAY

4 Soft damp brown medium sand CLAY

5 Very soft very damp brown SANDY LOAM with some small Gravel

6 Soft to medium damp brown SANDY LOAM

7 Soft to medium damp brown SANDY LOAM

8 Very dense med. gray CLAY

The Unconfined Compressive Strength (UCS) Failure Mode is indicated by (B-Bulge, S-Shear, P-Penetrometer)  
The SPT (N value) is the sum of the last two blow values in each sampling zone (AASHTO T206)  
BBS, from 137 (Rev. 8-99)

**ESCA**  
CONSULTANTS, INC.

DESIGNED BY: RDP/ELH 03/10  
DRAWN BY: DWH/HAS 03/10  
CHECKED BY: ELH 03/10  
APPROVED BY: RDP 03/10

**BORING LOGS**  
**STRUCTURE NO. 051-2008**

SHEET NO. 10	F.A.P. RTE. 781	SECTION 109B-1	COUNTY LAWRENCE	TOTAL SHEETS 34	SHEET NO. 24
CONTRACT NO. 74105					
FED. ROAD DIST. NO. ILLINOIS FED. AID PROJECT					





STATE OF ILLINOIS  
DEPARTMENT OF PUBLIC WORKS & BUILDINGS  
DIVISION OF HIGHWAYS

SHEET NO.  
1515A

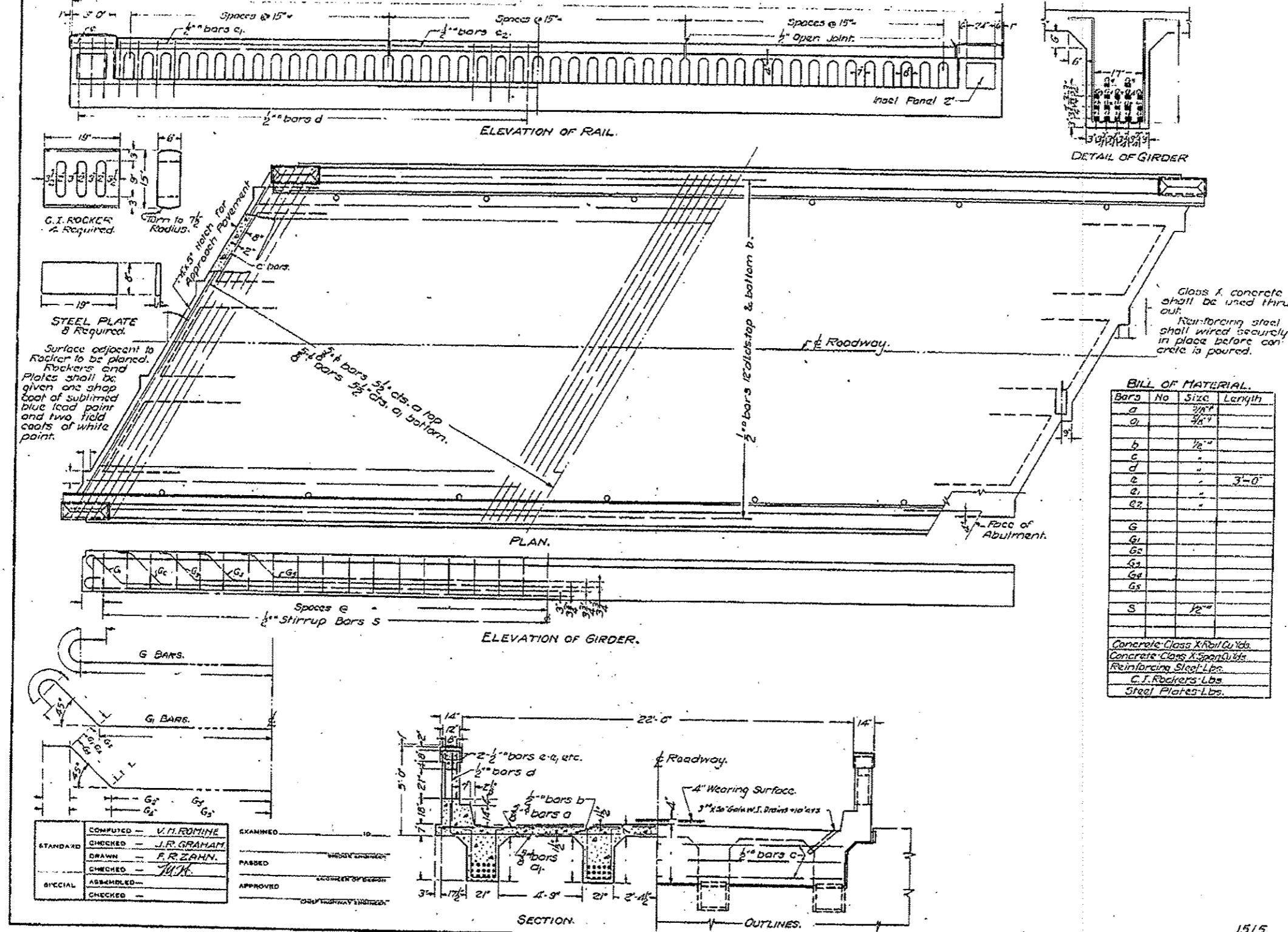

COMPUTED	V. H. ROMINE	EXAMINED	
CHECKED	J. R. GRAHAM	PASSED	WESLEY CHRISTIAN
DRAWN	F. R. ZANN	APPROVED	CLAYTON W. HARRIS
CHECKED	J. H. M.		
SPECIAL			
CHECKED			

FOR INFORMATION ONLY













DATE	
BY	
FINAL SURVEY	
PLOTTED	
REPLATE	
NOTE BOOK	
AREAS CHECKED	
NO.	

DATE	
BY	
ORIGINAL SURVEY	
PLOTTED	
REPLATE	
NOTE BOOK	
AREAS CHECKED	
NO.	

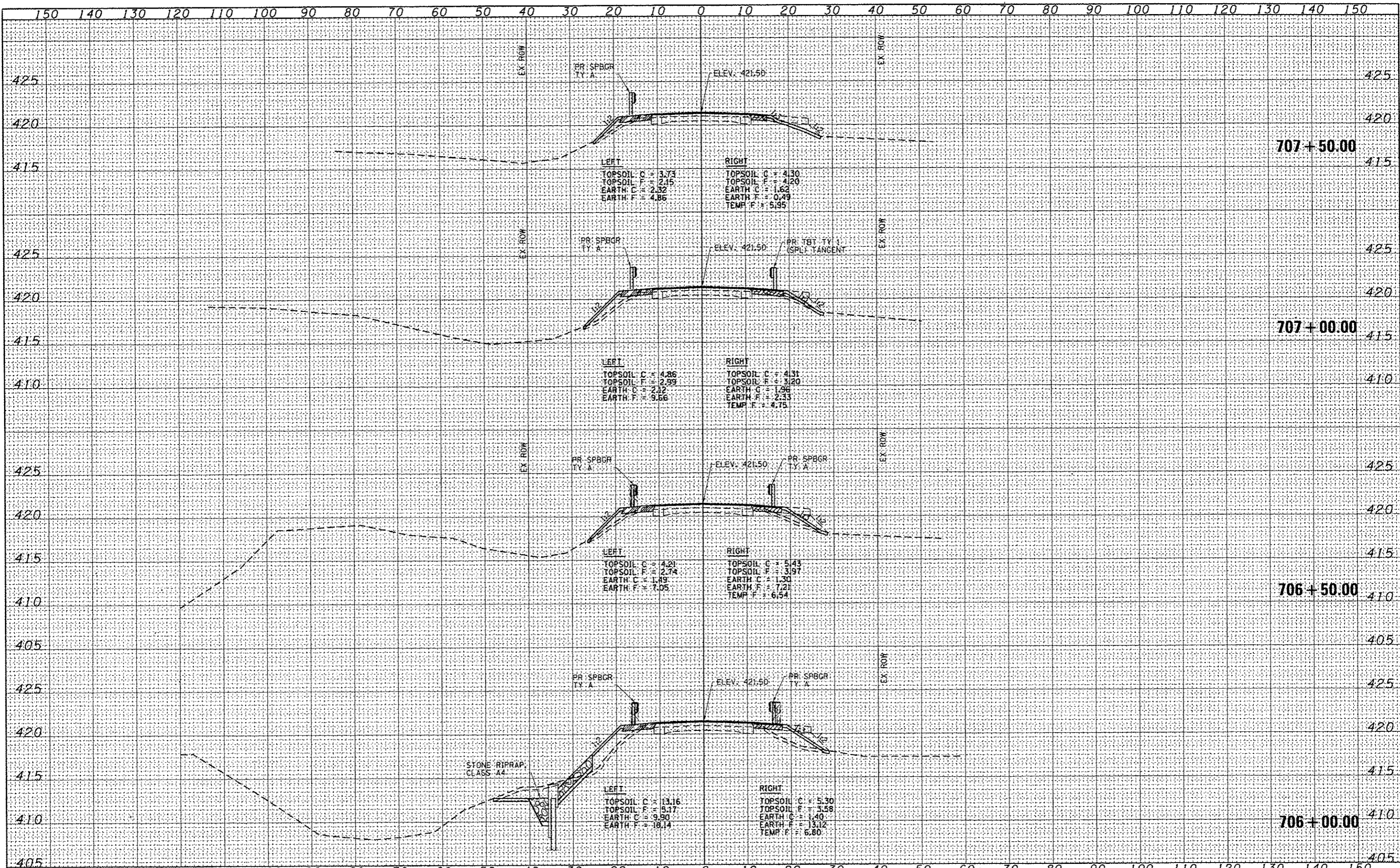

FILE NAME =	USER NAME = staffennk	DESIGNED - DAJ	REVISED -	STATE OF ILLINOIS DEPARTMENT OF TRANSPORTATION	FAP 781 (IL 33) CROSS SECTIONS	F.A.P. RTE.	SECTION	COUNTY	TOTAL SHEETS	SHEET NO.
BR242B000\p000\staffennk\08273139\0774105-11-11.dgn	DRAWN - RJT/HAS	REVISED -	781			109B-1	LAWRENCE	34	32	
PLOT SCALE = 28.8000' / in.	CHECKED - ELH	REVISED -	CONTRACT NO. 74105							
PLOT DATE = 6/22/2014 1:36:28 PM	DATE - 06/11	REVISED -	FED. ROAD DIST. NO. ILLINOIS FED. AID PROJECT							
SCALE: (HORIZ) 1"=10' (VERT) 1"=5'					SCALE: AS SHOWN	SHEET NO. 4 OF 6 SHEETS	STA. 706+00	TO STA. 707+50		



DATE	
BY	
NO.	
FINAL SURVEY	
NOTE BOOK	
NO.	
EXAMINED	
PLOTTED	
TEMPLATE	
AREAS	
AREAS CHECKED	

DATE	
BY	
NO.	
ORIGINAL SURVEY	
NOTE BOOK	
NO.	
EXAMINED	
PLOTTED	
TEMPLATE	
AREAS	
AREAS CHECKED	

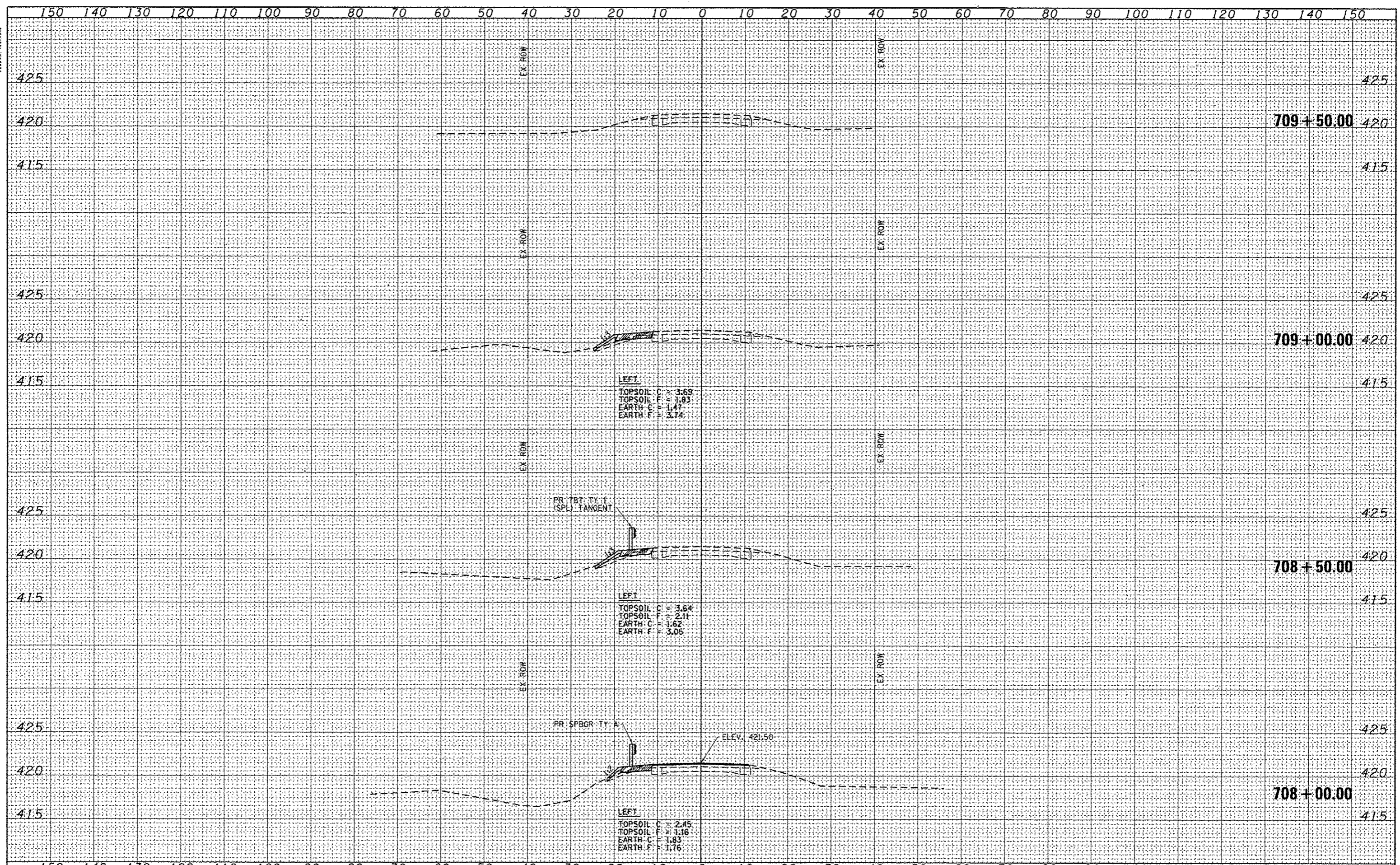

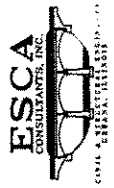

DATE	
BY	
ORIGINAL SURVEY	
REVISION	
PLANNING	
DESIGN	
CONSTRUCTION	
AS-BUILT	
NO.	

DATE	
BY	
ORIGINAL SURVEY	
REVISION	
PLANNING	
DESIGN	
CONSTRUCTION	
AS-BUILT	
NO.	

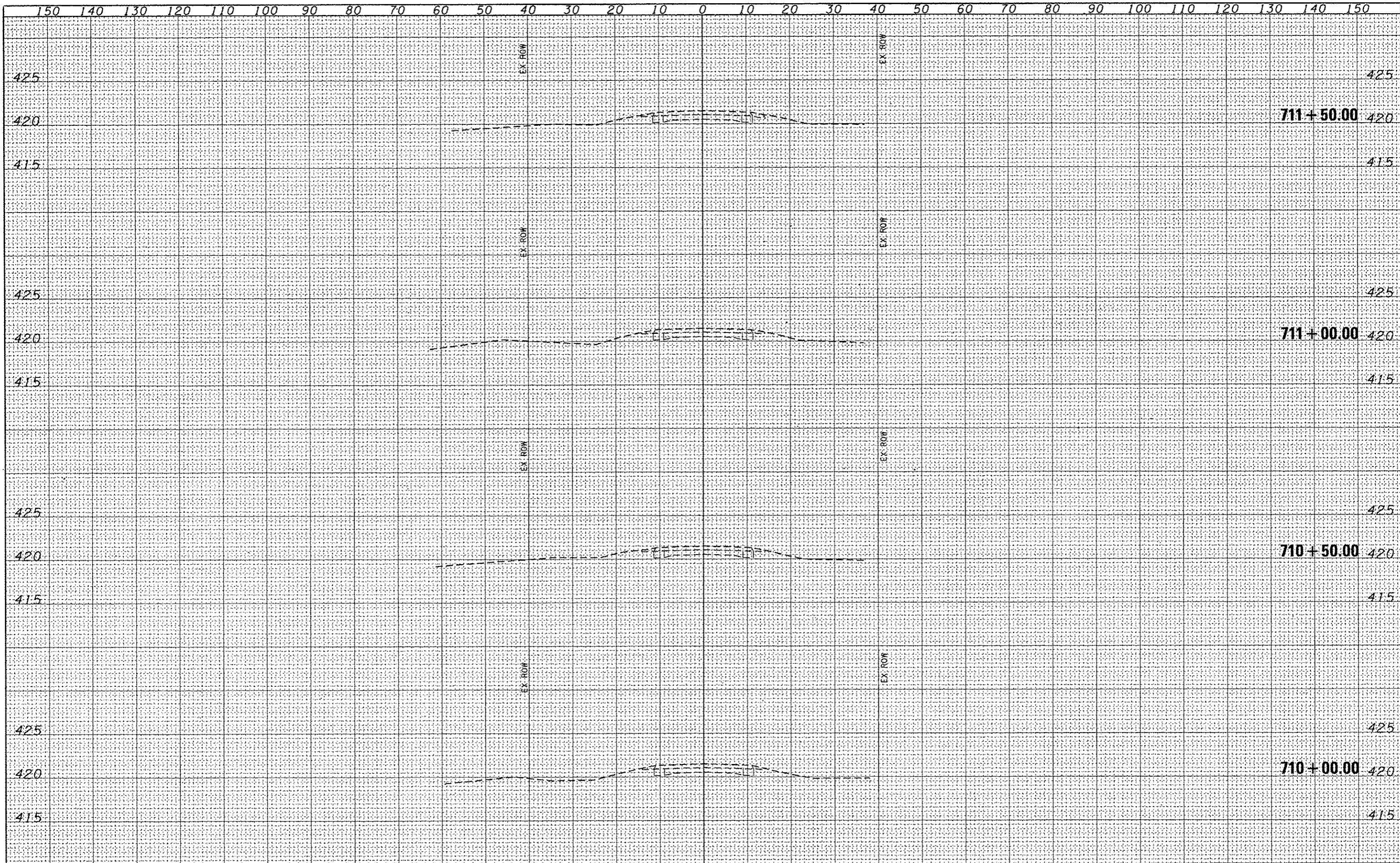

FILE NAME	USER NAME	DESIGNED	REVISED	STATE OF ILLINOIS DEPARTMENT OF TRANSPORTATION		FAP 781 (IL 33) CROSS SECTIONS		F.A.P. RTE.	SECTION	COUNTY	TOTAL SHEETS	SHEET NO.
B:\Projects\1098-1\1098-1.dgn	staffanik	DAJ				781	1098-1	LAWRENCE	34	34		
SCALE: 20.0000' / in.	CHECKED	DATE	REVISED	SCALE: AS SHOWN		SHEET NO. 6 OF 6 SHEETS	STA. 710+00	TO STA. 711+50	FED. ROAD DIST. NO.	ILLINOIS FED. AID PROJECT	CONTRACT NO. 74105	
SCALE: (HORIZ) 1"=10' (VERT) 1"=5'	PLOT DATE	06/11										