

END VIEW

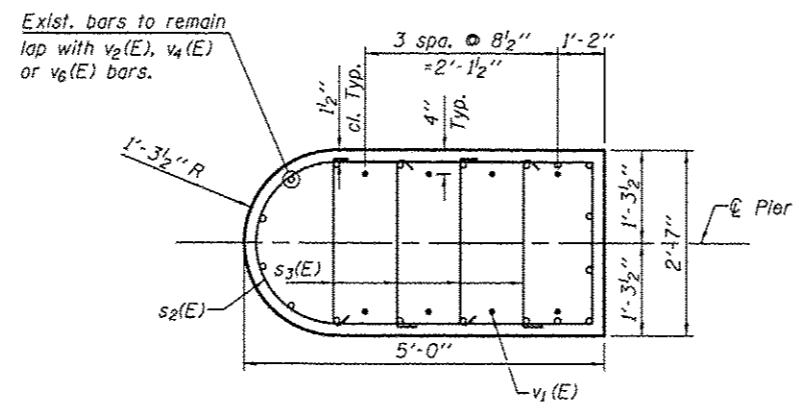

SECTION B-B

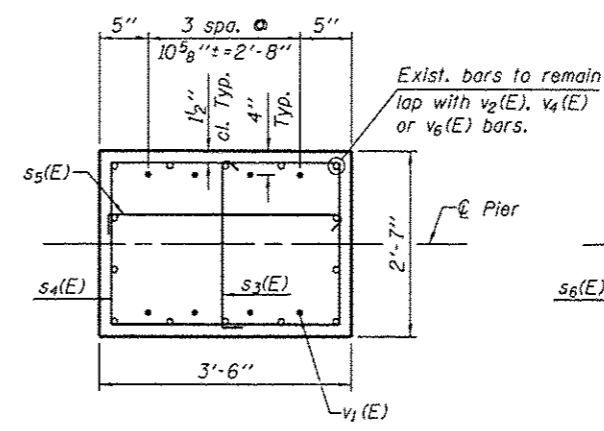

SECTION C-C

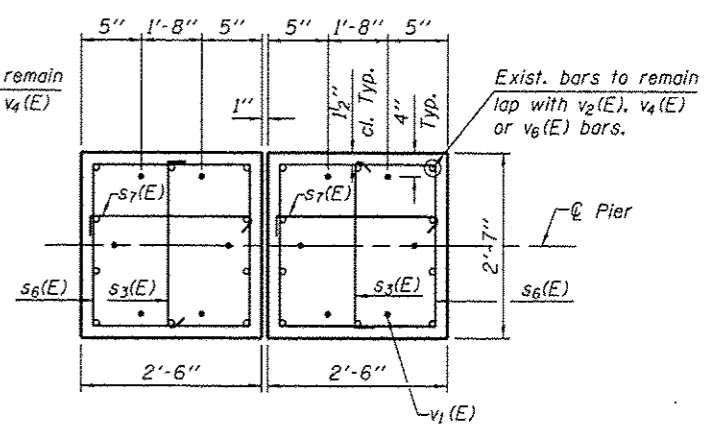

SECTION D-D

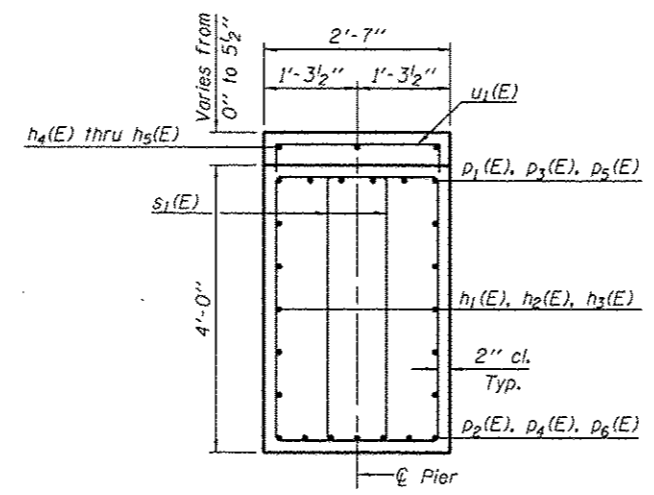

SECTION A-A

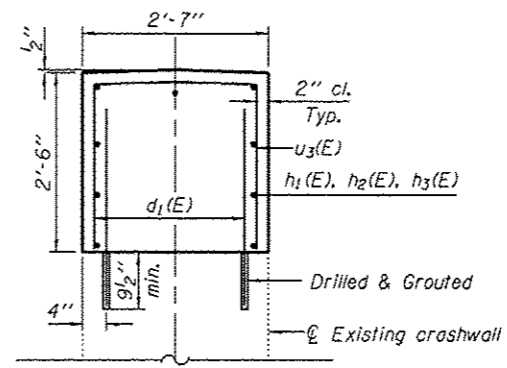

SECTION E-E

* The Location of the elevation at the top of crashwall shown in the Pier Elevation view.

**For Piers 1 & 4 only.

H:\Jobs\2011\201103022\CAD\Structural\dgn\016-1149_Final\00\0160J15-s46-pier-d1.dgn 5/20/2013 10:24:18 AM

GRÄEF
8501 W. Higgins Road, Suite 280
Chicago, Illinois 60631 (773) 399-0112

USER NAME :	DESIGNED - J.Z.	REVISED -
PLDT SCALE :	CHECKED - J.A.Z.	REVISED -
PLDT DATE :	DRAWN - E.E.J.	REVISED -
	DATE - 5/17/2013	REVISED -

STATE OF ILLINOIS
DEPARTMENT OF TRANSPORTATION

PIER DETAILS
STRUCTURE NO. 016-1149

SHEET NO. 546 OF 50 SHEETS

F.A.I. RTE.	SECTION	COUNTY	TOTAL SHEETS	SHEET NO.
94	1920-B	COOK	137	105
CONTRACT NO. 60J15				
ILLINOIS FED. AID PROJECT				