

DETAIL B

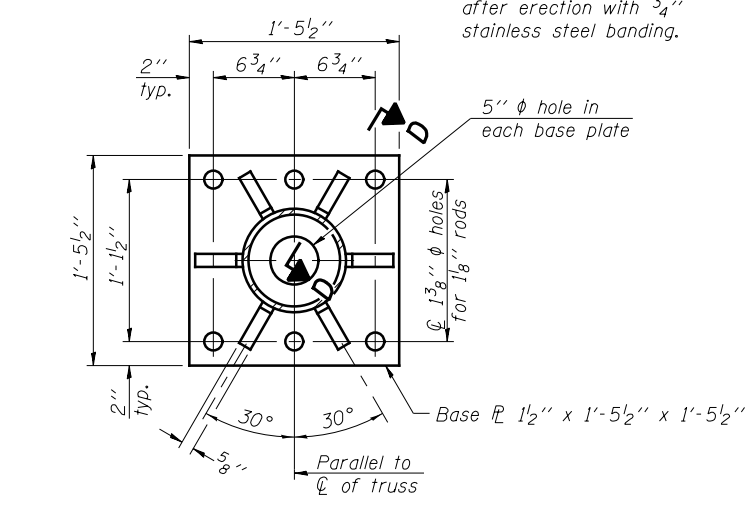

SECTION B-B

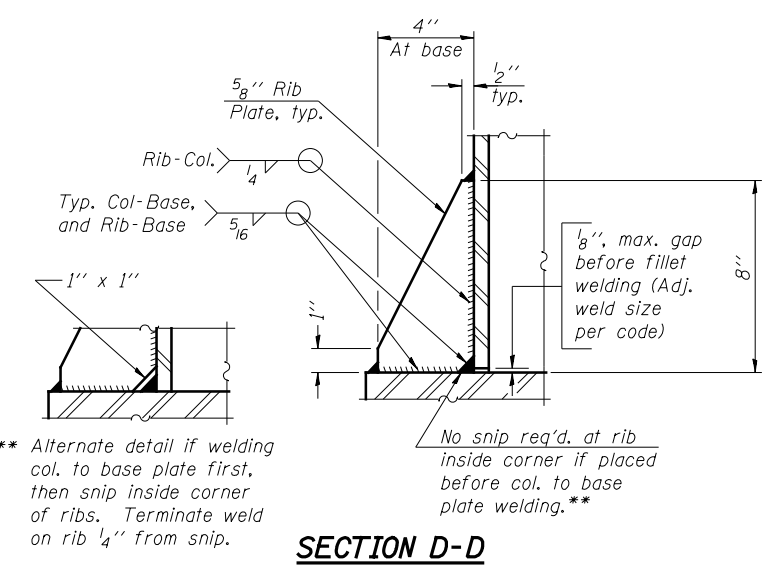

SECTION D-D

** Alternate detail if welding col. to base plate first, then snip inside corner of ribs. Terminate weld on rib 1/4" from snip.

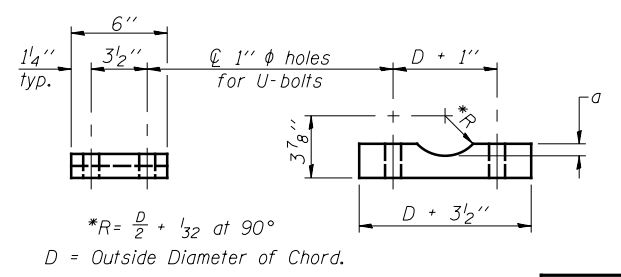

SADDLE SHIM DETAIL

ASTM B26 Alloy 356-F or ASTM B209 Alloy 6061-T651 (4 required per sign truss)

| Truss Chord Nominal Dia. | a |
|--------------------------|--------|
| 5" | 3/4" |
| 5 1/2" | 13/16" |
| 6" | 7/8" |
| 6 1/2" | 15/16" |

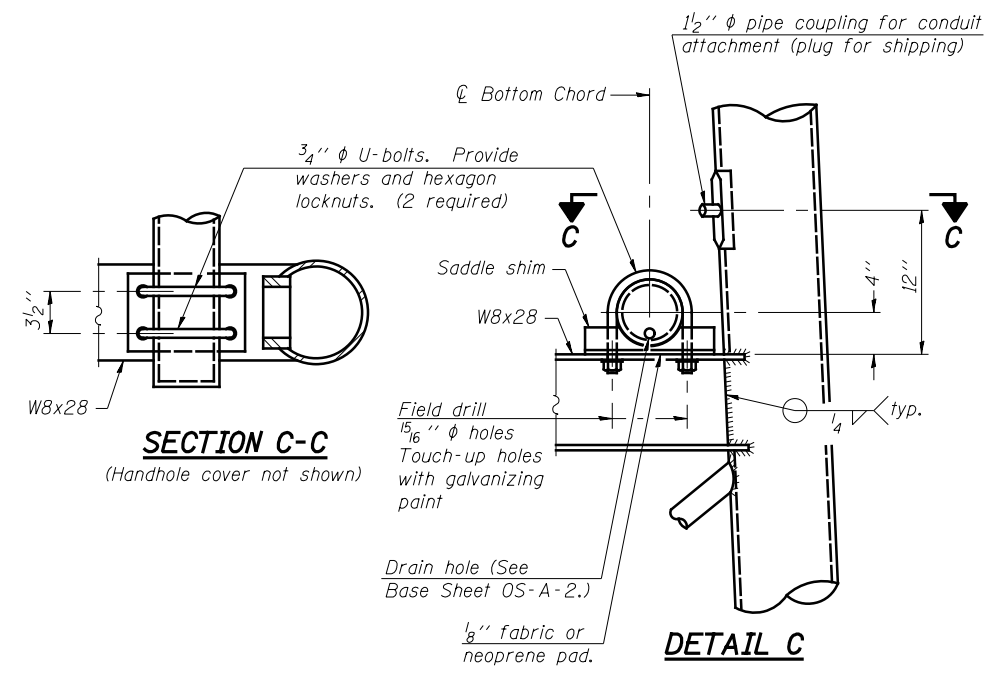

SECTION C-C

DETAIL C

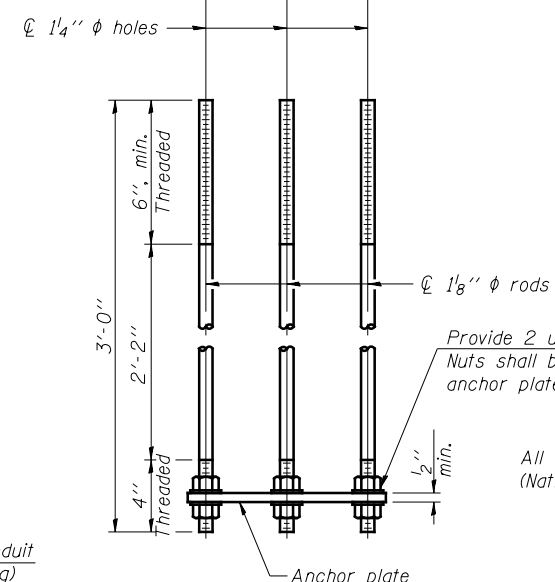
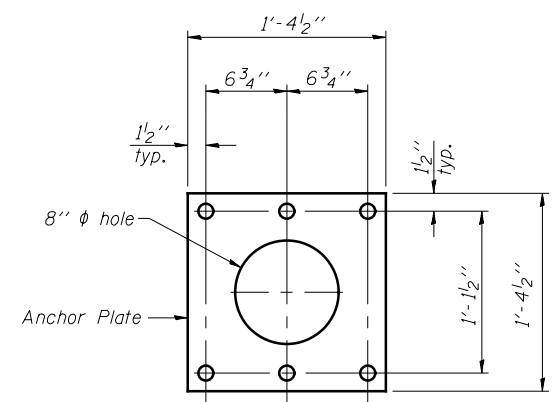

ANCHOR ROD DETAIL
Spread Footing Foundation

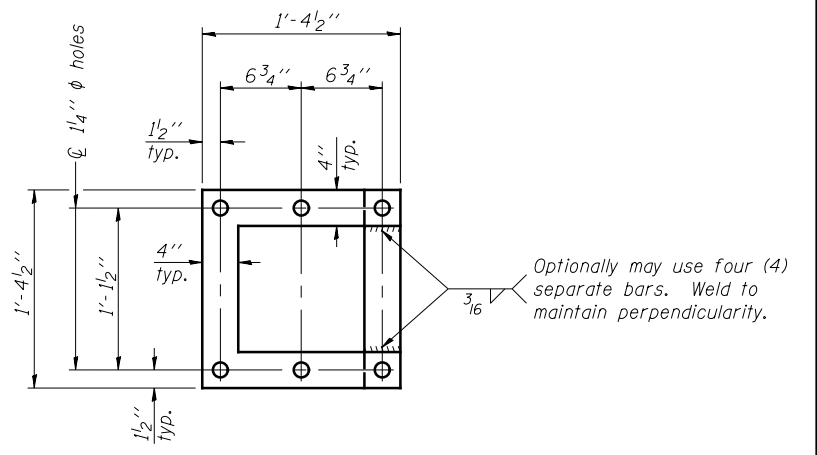

POSITIONING PLATE(S)

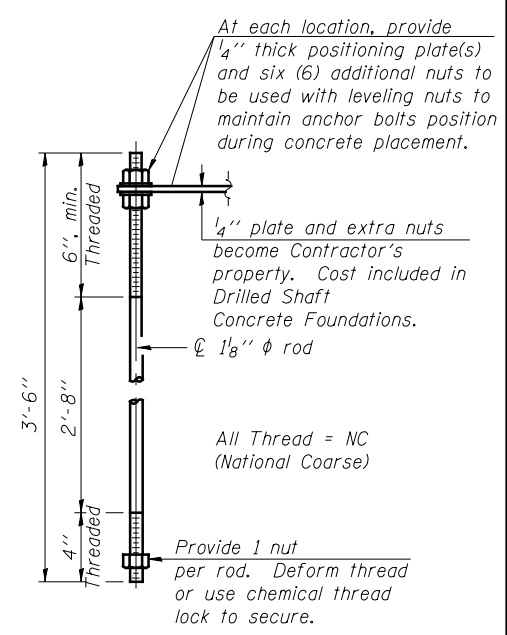

ANCHOR ROD DETAIL
Drilled Shaft Foundation

Anchor rods shall conform to ASTM F1554 Grade 105. Galvanize upper 12" minimum per AASHTO M232. No welding shall be permitted on rods.

TYPE I-A TRUSS
8" ϕ PIPE SUPPORT FRAME DETAILS

OS-A-4A

6-1-12

| | | | |
|-------------|-------------|----------------|-----------|
| FILE NAME = | USER NAME = | DESIGNED - ESW | REVISED - |
| | | CHECKED - JWS | REVISED - |
| | | DRAWN - PDB | REVISED - |
| | | CHECKED - BRM | REVISED - |

STATE OF ILLINOIS
DEPARTMENT OF TRANSPORTATION

OVERHEAD SIGN STRUCTURES
SUPPORT FRAME DETAILS - ALUMINUM TRUSS

SHEET NO. 29 OF 53 SHEETS

| | | | | |
|--------------------|---------|-----------|---------------------------|-----------|
| F.A.I. RTE. | SECTION | COUNTY | TOTAL SHEETS | SHEET NO. |
| 57/70 | (25-4R) | EFFINGHAM | 1760 | 416 |
| CONTRACT NO. 74295 | | | ILLINOIS FED. AID PROJECT | |