

**WB WEST ABUTMENT TEMPORARY SHEET PILING ELEVATION**

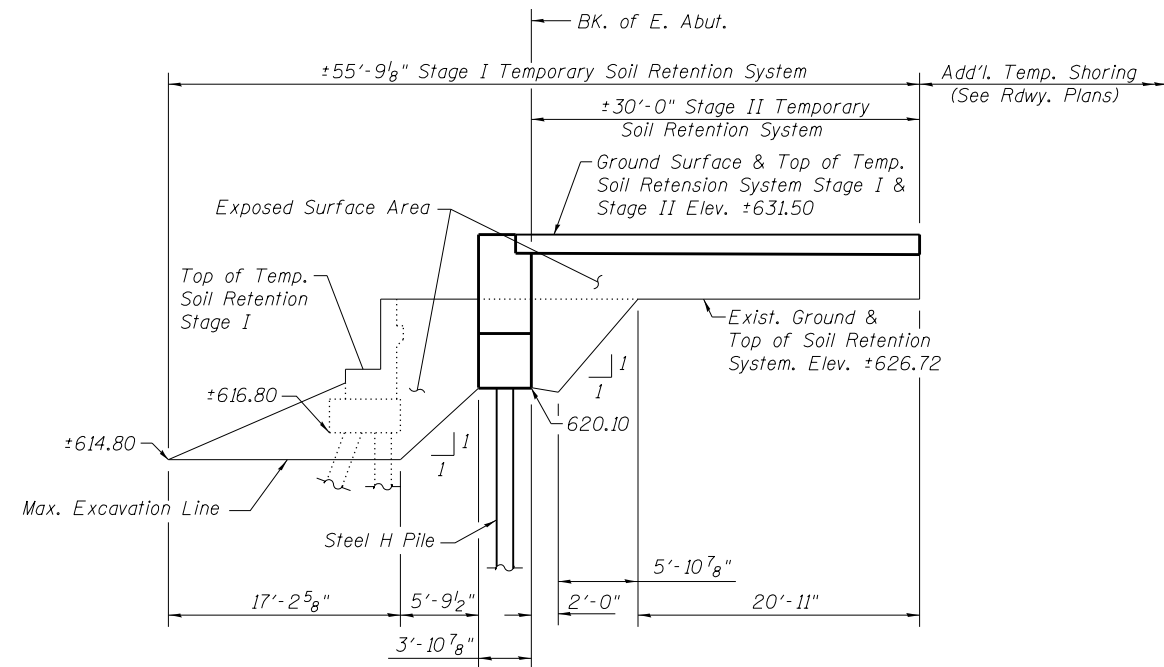

**WB EAST ABUTMENT TEMPORARY SOIL RETENTION SYSTEM**

Notes:  
 Slopes are shown along face of sheeting or Temporary Soil Retention System.  
 A cantilevered sheet piling design does not appear feasible at the East Abutments and additional members or other retention systems may be necessary. The Contractor shall submit a temporary soil retention system design including plan details and calculations for review and acceptance by the Engineer.  
 If the Contractor chooses to alter the temporary cantilevered sheet piling design requirements shown in the plans, a design submittal including plan details and calculations will be provided for review and acceptance by the Engineer.

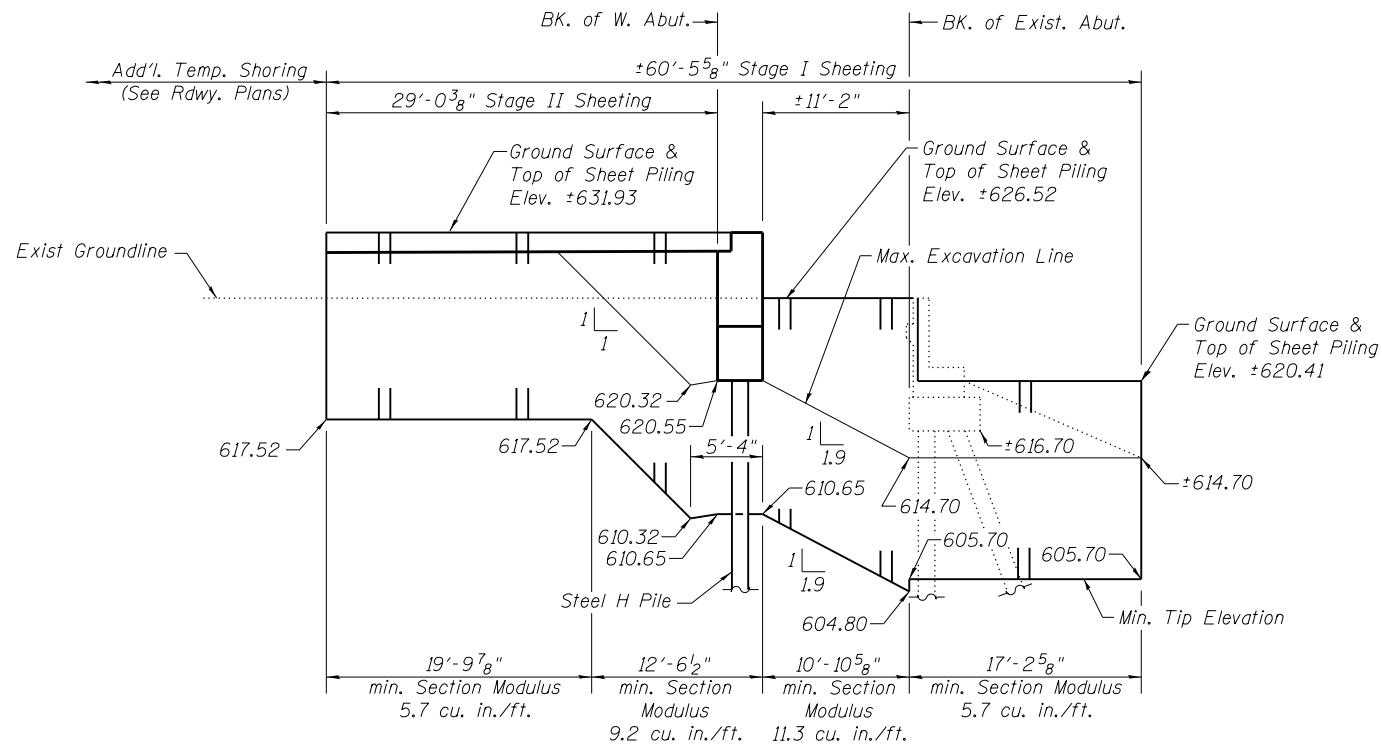

**EB WEST ABUTMENT TEMPORARY SHEET PILING ELEVATION**

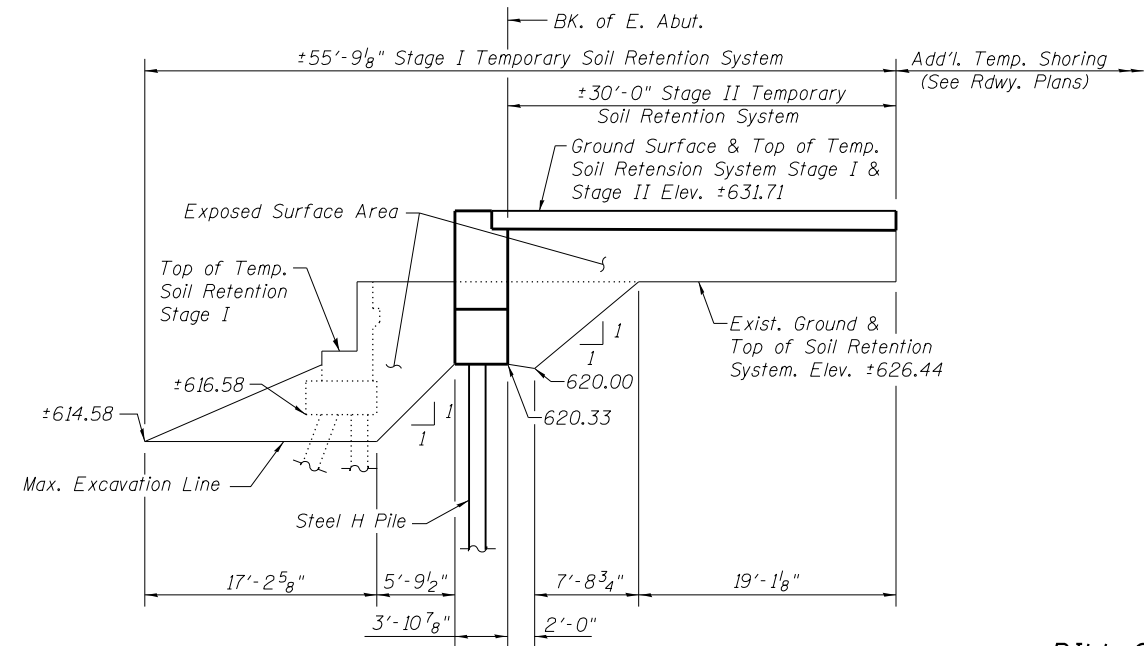

**EB EAST ABUTMENT TEMPORARY SOIL RETENTION SYSTEM**

**BILL OF MATERIAL**

Item	Unit	Total
Temporary Sheet Piling	Sq. Ft.	3061
Temporary Soil Retention System	Sq. Ft.	1131