

SECTION D-D

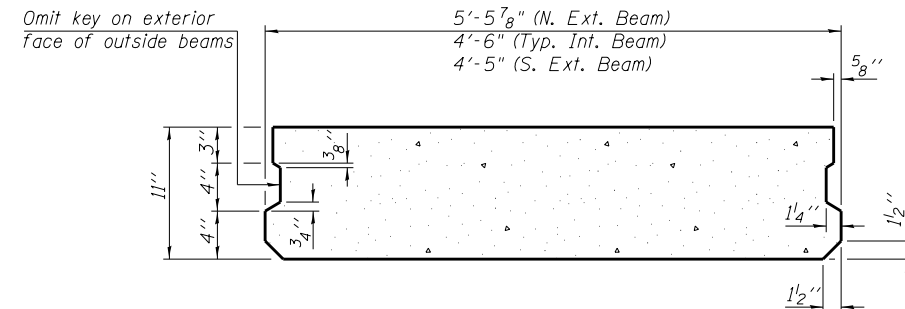

SECTION E-E
(Showing dimensions)

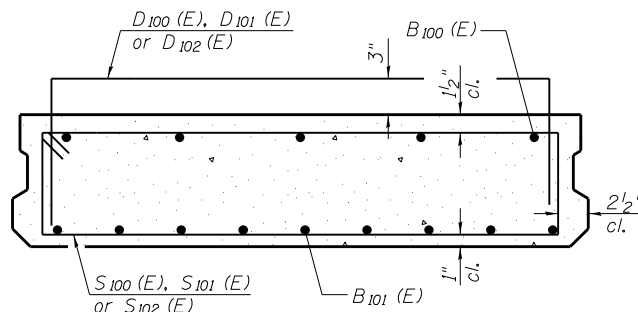

SECTION E-E
(Showing reinforcement)

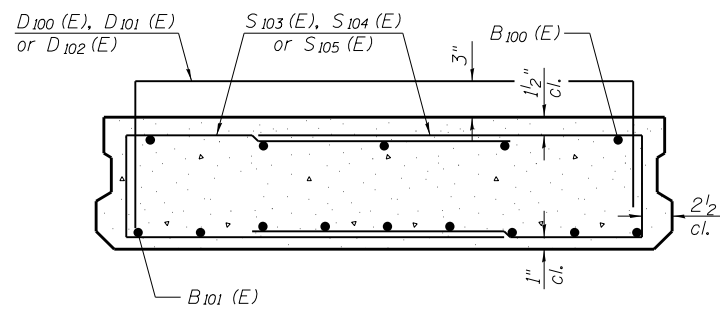

VIEW F-F
(Showing reinforcement)

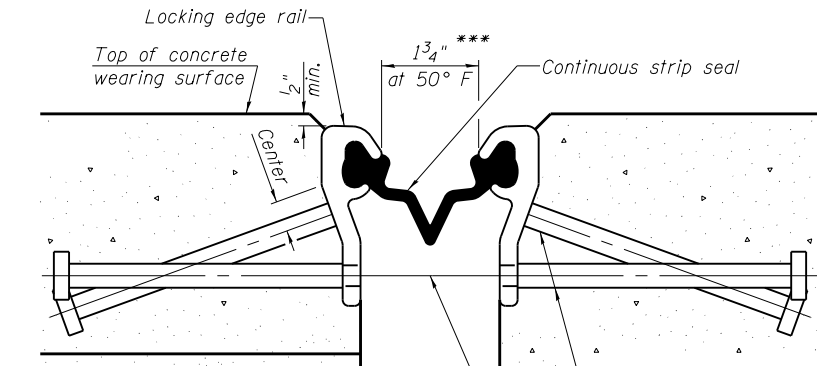

SECTION THRU STRIP SEAL JOINT
(at rt. angles)

7/16" ϕ holes at 4'-0" cts. for 3/8" ϕ bolts. All bolts shall be burned, sawed, or chipped off flush with the plates after forms are removed, typ.

Place 1/2" ϕ x 6" granular or solid flux filled headed studs conforming to Article 1006.32 of the Std. Specs., automatically end welded at 1'-0" alt. cts.

Precast Bridge Approach Slab

Bridge Approach Pavement Connector

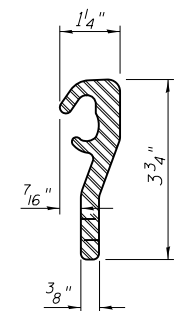

ROLLED (EXTRUDED) RAIL

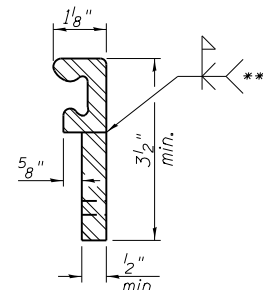

WELDED RAIL

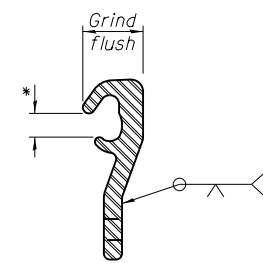

LOCKING EDGE RAIL SPLICE

Rolled rail shown, welded rail similar.

LOCKING EDGE RAIL

- * Omit weld at seal opening.
- ** Back gouge not required if complete joint penetration is verified by mock-up.
- *** The joint opening shall be determined per Article 520.04 except that on jointless structures, the distance described as the bridge length between the nearest fixed bearings each way from the joint shall be taken as half the bridge length plus the approach slab length. The minimum dimension shall be 1 1/2" for installation purposes.

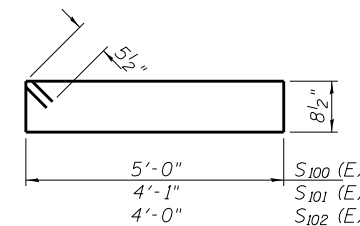

BARS S100 (E), S101 (E) & S102 (E)

BAR LIST
NORTH EXTERIOR BEAM
(For information only)

Bar	No.	Size	Length	Shape
B100 (E)	6	#5	29'-8"	—
B101 (E)	13	#9	29'-8"	—
D100 (E)	31	#4	7'-11"	□
S100 (E)	58	#5	12'-4"	▣
S103 (E)	12	#5	12'-7"	▣

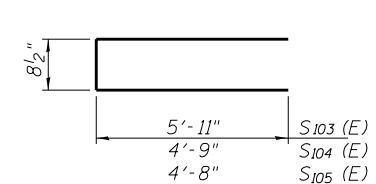

BARS S103 (E), S104 (E) & S105 (E)

BAR LIST
EACH INTERIOR BEAM
(For information only)

Bar	No.	Size	Length	Shape
B100 (E)	5	#5	29'-8"	—
B101 (E)	11	#9	29'-8"	—
D101 (E)	22	#4	6'-9"	□
S101 (E)	58	#5	10'-6"	▣
S104 (E)	12	#5	10'-3"	▣

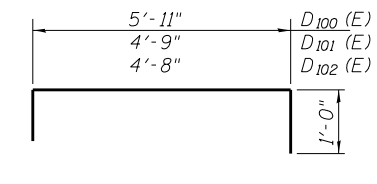

BARS D100 (E), D101 (E) & D102 (E)

BAR LIST
SOUTH EXTERIOR BEAM
(For information only)

Bar	No.	Size	Length	Shape
B100 (E)	5	#5	29'-8"	—
B101 (E)	11	#9	29'-8"	—
D102 (E)	41	#4	6'-8"	□
S102 (E)	58	#5	10'-4"	▣
S105 (E)	12	#5	10'-1"	▣

Notes:

- The precast bridge approach slab shall be according to Section 504 of the Standard Specifications and shall be paid for at the contract unit price per square foot for Precast Bridge Approach Slab.
- Cast-in-place substitution of Precast Bridge Approach Slab is not allowed. Parapet concrete shall be paid for as Concrete Superstructure.
- Parapet and wearing surface reinforcement shall be paid for as Reinforcement Bars, Epoxy Coated.
- Approach footing concrete shall be paid for as Concrete Structures.
- The top surface of precast bridge approach slabs shall be roughened to a depth of 1/4" according to the IDOT "Manual for Fabrication of Precast Prestressed Concrete Products."
- After precast bridge approach slab has been erected, holes shall be drilled into abutment and anchor dowels placed. Dowel holes shall be filled with non-shrink grout to top of precast slab and allowed to cure fully prior to grouting the longitudinal shear keys.
- Two 1/8" fabric adjusting shims of the dimensions of the exterior bearing pad shall be provided for each bearing pad location. Cost included with Precast Bridge Approach Slab.
- A minimum 2 1/2" ϕ lifting pins shall be used to engage the lifting loops during handling.
- Compressive strength of precast concrete, f'c shall be 6,000 psi.
- For additional parapet details, see sheet 37 of 79.
- Any concrete poured monolithically with the wearing surface, such as curbs, will not be paid for separately, but will be included in the cost of Concrete Wearing Surface, 5 1/4".
- The strip seal shall be made continuous and shall have a minimum thickness of 1/4". The configuration of the strip seal shall match the configuration of the Locking Edge Rails.
- The height and thickness of the Locking Edge Rails shown are minimum dimensions. The actual configuration of the Locking Edge Rails and matching strip seal may vary from manufacturer to manufacturer. Flanged edge rails will not be allowed.
- The inside of the Locking Edge Rail groove shall be free of weld residue. Locking Edge Rails may be spliced at slope discontinuities and stage construction joints.
- The manufacturer's recommended installation methods shall be followed. All steel components shall be galvanized after fabrication according to Article 520.03 of the Standard Specifications.
- Maximum space between rail segments at stage lines shall be 3/16", sealed with a suitable sealant.
- Quantity for Diamond Grinding (Bridge Section) and Bridge Deck Grooving included in Bill of Materials on sheet 25 of 79.
- Order e115 (E) bars full length and cut to fit skew.
- See sheet 36 of 79 for joint termination details.
- See sheet 36 of 79 for Bar Bends.

WEST APPROACH BILL OF MATERIAL

Bar	No.	Size	Length	Shape
a113 (E)	31	#4	37'-11"	□
a114 (E)	31	#4	22'-4"	□
a115 (E)	31	#4	30'-0"	□
a116 (E)	15	#4	7'-5"	□
b105 (E)	76	#4	29'-8"	—
b106 (E)	3	#4	14'-8"	—
d102 (E)	51	#5	6'-10"	▣
d105 (E)	51	#5	5'-11"	▣
e115 (E)	8	#4	30'-7"	—
e116 (E)	1	#8	30'-7"	—
e117 (E)	8	#4	14'-8"	—
e118 (E)	1	#8	14'-8"	—
t100 (E)	154	#4	11'-5"	—
w100 (E)	40	#5	37'-7"	—
w101 (E)	80	#5	26'-4"	—
Concrete Superstructure			Cu. Yd.	5.8
Concrete Structures			Cu. Yd.	40.0
Reinforcement Bars, Epoxy Coated			Pound	9460
Precast Bridge Approach Slab			Sq. Ft.	2273
Concrete Wearing Surface, 5"			Sq. Yd.	252.5
Preformed Joint Strip Seal			Foot	89