

* As alternate to bolted connection shown, the guide bars may be connected to the top bearing plate by groove welds or the guide bars and top bearing plate may be fabricated as a single piece.

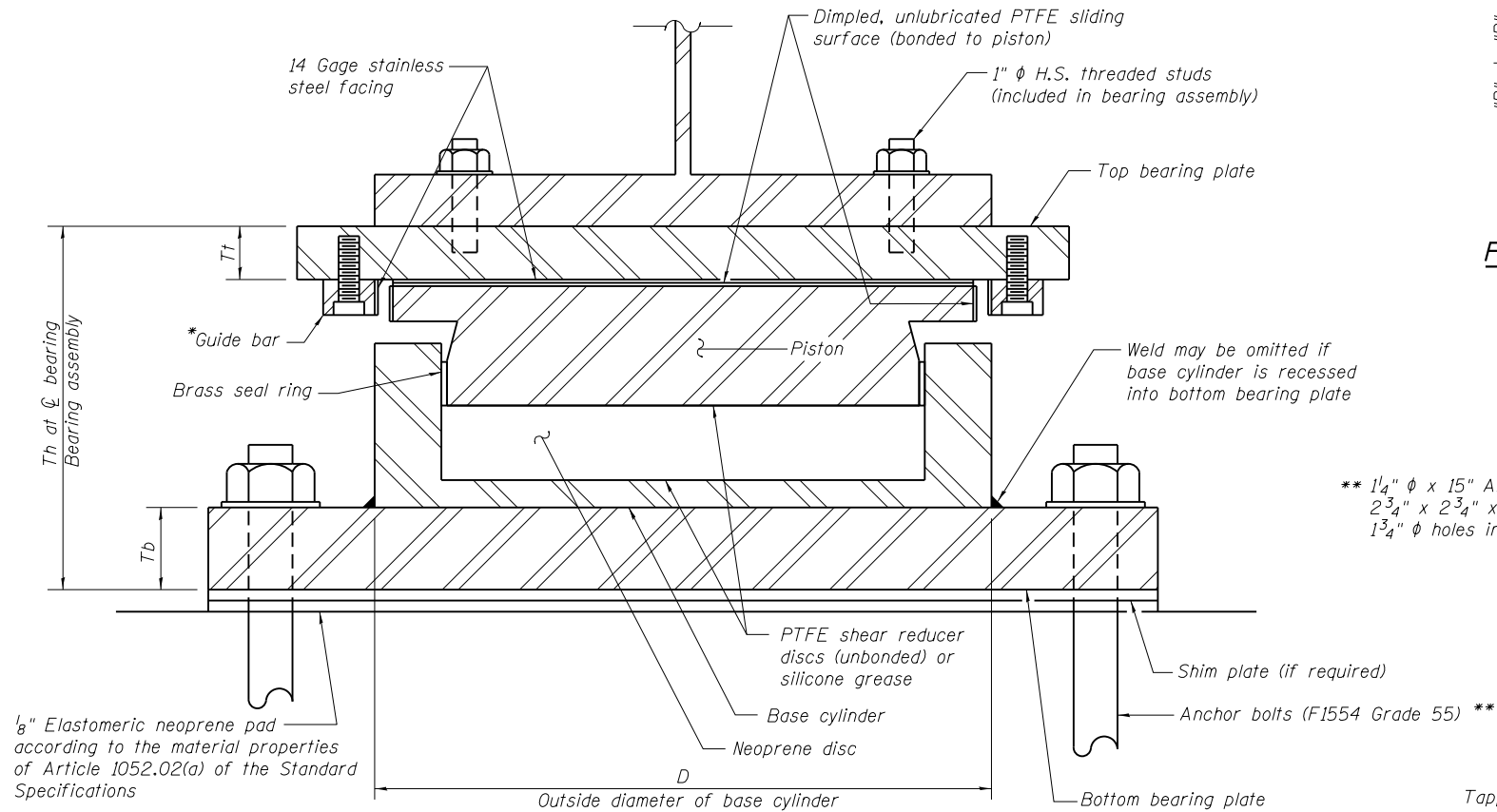

GUIDED EXPANSION POT BEARING
(Pier)

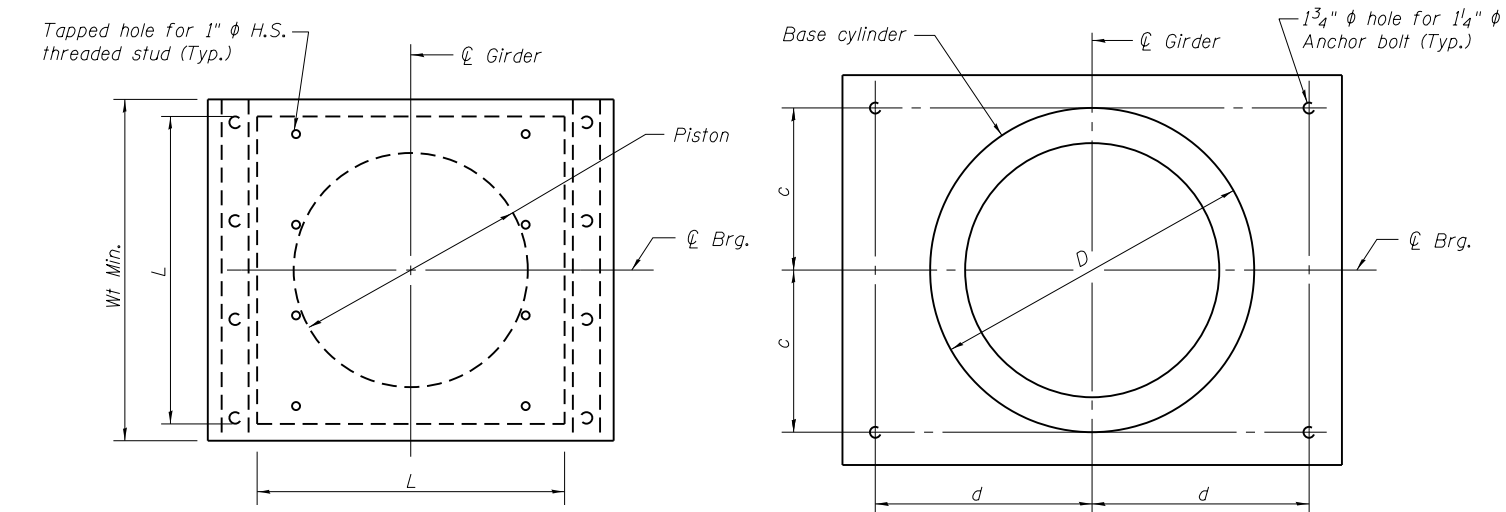

TOP BEARING PLATE AND PISTON PLAN

BOTTOM BEARING PLATE AND BASE CYLINDER PLAN

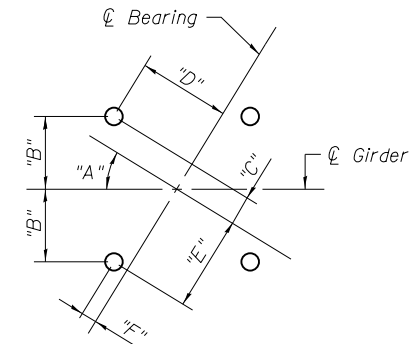

PIER ANCHOR BOLT LOCATION DETAIL

WESTBOUND STRUCTURE 025-0111

Location	Girder	Angle "A"	"B" (in.)	"C" (in.)	"D" (in.)	"E" (in.)	"F" (in.)
Pier 1	1	32°08'00"	12 7/8"	5 3/8"	1'-3 5/8"	1'-4 3/8"	2"
Pier 2	2	31°49'04"	12 7/8"	5 1/2"	1'-3 5/8"	1'-4 3/8"	2"
Pier 3	3	31°30'00"	12 7/8"	5 1/2"	1'-3 5/8"	1'-4 3/8"	2 1/8"
Pier 4	4	31°30'00"	12 7/8"	5 1/2"	1'-3 5/8"	1'-4 3/8"	2 1/8"
Pier 5	5	31°30'00"	12 7/8"	5 1/2"	1'-3 5/8"	1'-4 3/8"	2 1/8"
Pier 6	6	31°30'00"	12 7/8"	5 1/2"	1'-3 5/8"	1'-4 3/8"	2 1/8"
Pier 7	7	31°30'00"	12 7/8"	5 1/2"	1'-3 5/8"	1'-4 3/8"	2 1/8"
Pier 8	8	31°30'00"	12 7/8"	5 1/2"	1'-3 5/8"	1'-4 3/8"	2 1/8"
Pier 9	9	31°30'00"	12 7/8"	5 1/2"	1'-3 5/8"	1'-4 3/8"	2 1/8"

EASTBOUND STRUCTURE 025-0112

Location	Girder	Angle "A"	"B" (in.)	"C" (in.)	"D" (in.)	"E" (in.)	"F" (in.)
Pier 10	10	31°30'00"	12 7/8"	5 1/2"	1'-3 5/8"	1'-4 3/8"	2 1/8"
Pier 11	11	31°30'00"	12 7/8"	5 1/2"	1'-3 5/8"	1'-4 3/8"	2 1/8"
Pier 12	12	31°30'00"	12 7/8"	5 1/2"	1'-3 5/8"	1'-4 3/8"	2 1/8"
Pier 13	13	31°30'00"	12 7/8"	5 1/2"	1'-3 5/8"	1'-4 3/8"	2 1/8"
Pier 14	14	31°30'00"	12 7/8"	5 1/2"	1'-3 5/8"	1'-4 3/8"	2 1/8"
Pier 15	15	31°30'00"	12 7/8"	5 1/2"	1'-3 5/8"	1'-4 3/8"	2 1/8"
Pier 16	16	30°57'29"	12 7/8"	5 3/4"	1'-3 5/8"	1'-4 3/8"	2 1/4"
Pier 17	17	30°24'35"	12 7/8"	5 7/8"	1'-3 1/2"	1'-4 3/8"	2 3/8"
Pier 18	18	29°51'19"	12 7/8"	6"	1'-3 3/8"	1'-4 3/8"	2 5/8"
Pier 19	19	29°17'41"	12 7/8"	6 1/8"	1'-3 3/8"	1'-4 1/4"	2 3/4"

** 1 1/4" ϕ x 15" Anchor bolts
2 3/4" x 2 3/4" x 5/16" PL Washer under nut
1 3/4" ϕ holes in bottom PL, typ.

Tapped hole for 1" ϕ H.S. threaded stud (Typ.)

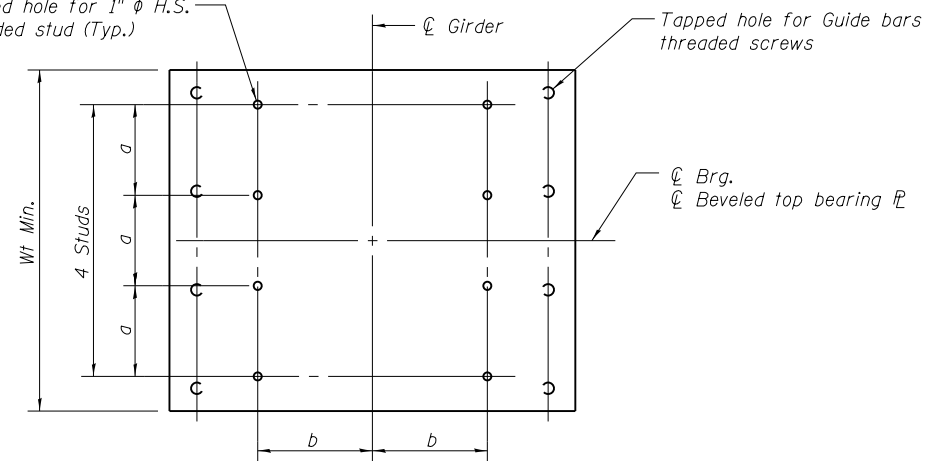

TOP BEARING PLATE PLAN

DIMENSIONS (IN)

Dimension	Pier
D	1'-11 3/4"
L	1'-9"
Tb	2 1/4"
Th	11 3/4"
Tt	1 7/8"
Wt	2'-2"
a	6"
b	5 1/4"
c	10 3/8"
d	1'-0 7/8"

DESIGN DATA

Data	Pier
Vertical Design Load (kips) (strength)	1130
Vertical Design Load (kips) (service)	770
Horizontal Design Load (kips) (strength)	150
Total Required Movement (in)	4
Maximum Factored Ultimate Strength Design Rotation, θ_u (Radians)	0.0065

BILL OF MATERIAL

Item	Unit	Total
High Load Multi-Rotation Bearings, Guided Expansion 1150K	Each	19
Anchor Bolts, 1 1/4" ϕ	Each	76

Notes:
The structural steel plates of the bearing assembly shall conform to the requirements of AASHTO M270 Grade 50.
Two 1/8" in. adjusting shims shall be provided for each bearing in addition to all other plates or shims and placed as shown on bearing details.
H.S. bolts in bearing assembly shall be galvanized according to AASHTO M298 Class 50.
The anchor bolt sizes and grades shown constitute a calculated seismic fuse. Substitution of higher diameter and/or grade anchor bolts will not be allowed.
Bearing dimensions and details shown are for a pot type HLMR bearing. Disc type HLMR bearing dimensions and details will vary.
All structural steel and exposed surfaces of bearings shall be painted as specified in Section 506 of the Standard Specifications.