 Locations where Cleaning and Painting Steel Bridge are Required on all exposed surfaces. See Section A-A for limits of application.  
 Locations where no painting is Required. (Reconstructed in 2008, Contract No. 74311)

\* Beams 2, 3 & 4 and Diaphragms D3 shall be protected during painting to prevent over spray.

**Notes:**  
 Cleaning and Painting of the existing structural steel shall be as specified in the special provision for "Cleaning and Painting Existing Steel Structures." All structural steel, including beams, bearings and diaphragms shall be cleaned by SSPC-SP10 Near White Metal Blast Cleaning. Fascia beams, in their entirety, shall be cleaned by SSPC-SP10 Near White Metal Blast Cleaning.  
 The designated areas cleaned per SSPC-SP10 Near White Blast Cleaning shall be painted according to the requirements of Painting System 1-OZ/E/U.  
 The color of the final finish coat for all steel surfaces, including the interior and fascia beams, brackets and bumpers, shall be Gray, Munsell No. 5B 7/1.  
 The Organic Zinc Rich Primer / Epoxy / Urethane Paint System shall be used for painting of new structural steel except where otherwise noted. The entire system shall be shop applied, with the exception that masked off connection surfaces, field installed fasteners and damaged areas shall be touched up in the field.  
 The existing structural steel contains lead. The Contractor shall take appropriate precautions to deal with the presence of lead on this project.  
 A minimum of 3 air monitors will be required to monitor abrasive blasting operations at this site. See special provision for "Containment and Disposal of Lead Paint Cleaning Residues."

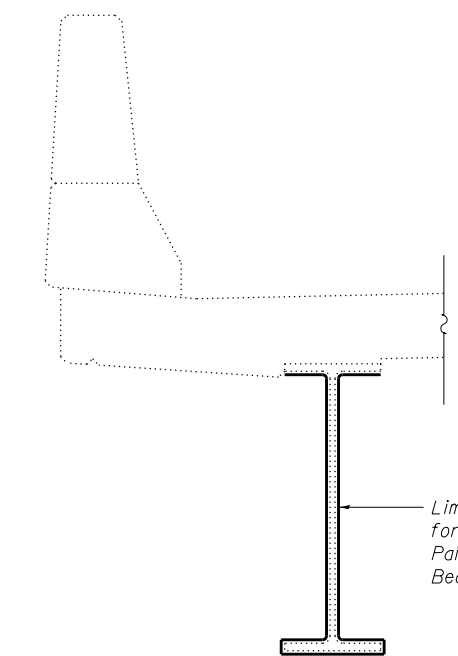
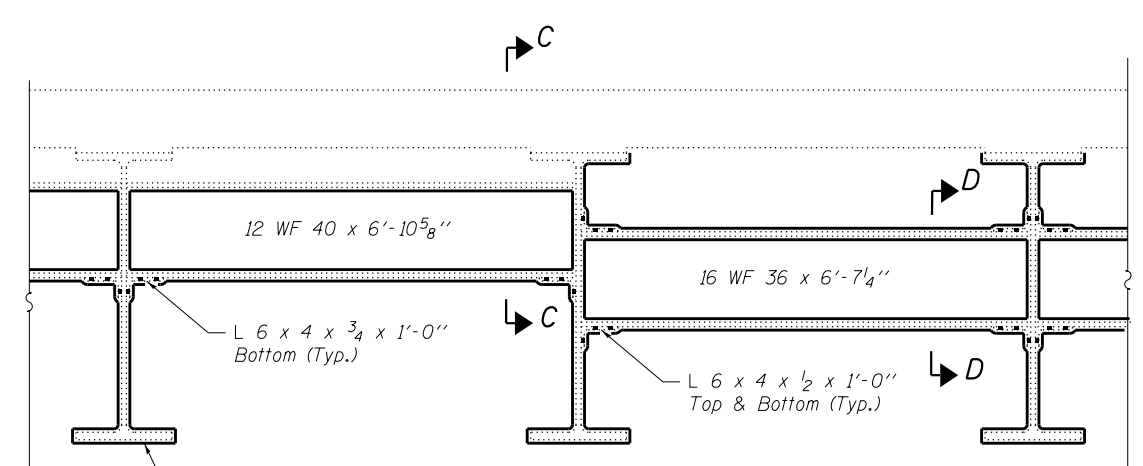

Limits of application for Cleaning and Painting Steel Bridge  
**SECTION A-A**  
 SHOWING DIAPHRAGM D1      SHOWING DIAPHRAGM D2  
**SECTION B-B**  
 Limits of application for Cleaning and Painting Steel Beams (Typ.)  
**SECTION C-C**  
 Limits of application for Cleaning and Painting Steel Bridge  
**SECTION D-D**

S:\Proj\025-0062\025-0062-TR-05-06-02\57-70-00-01\Drawings\Bridges\025-0062-TR-05-06-02.dgn

FILE NAME = 0250062-74295-020.dgn	USER NAME =	DESIGNED - B.B.	REVISED -
		CHECKED - A.C.S.	REVISED -
		DRAWN - B.B.	REVISED -
		CHECKED - C.J.F.	REVISED -
PLOT SCALE =	PLOT DATE = 2:29:51 PM 8/15/2013		

**STATE OF ILLINOIS  
DEPARTMENT OF TRANSPORTATION**

**PAINT DETAILS  
STRUCTURE NO. 025-0062**

SHEET NO. 20 OF 20 SHEETS

F.A.I. RTE.	SECTION	COUNTY	TOTAL SHEETS	SHEET NO.
70	(25-4HB-2)I	EFFINGHAM	1760	1760
CONTRACT NO. 74295				
ILLINOIS FED. AID PROJECT				