

SIDE ROAD TEMPORARY RAMP DETAIL
NOT TO SCALE

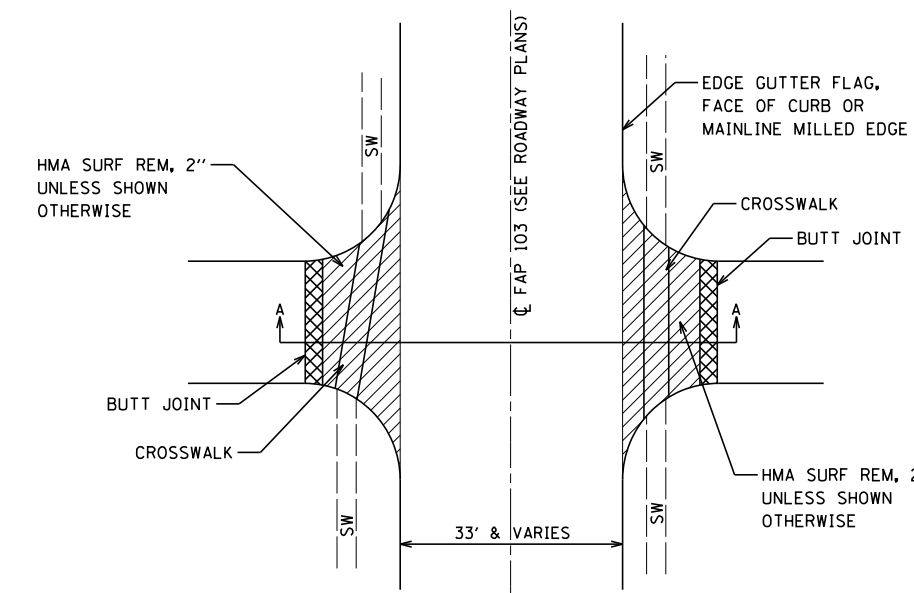

SIDE ROAD MILLING AND BUTT JOINT DETAIL
NOT TO SCALE

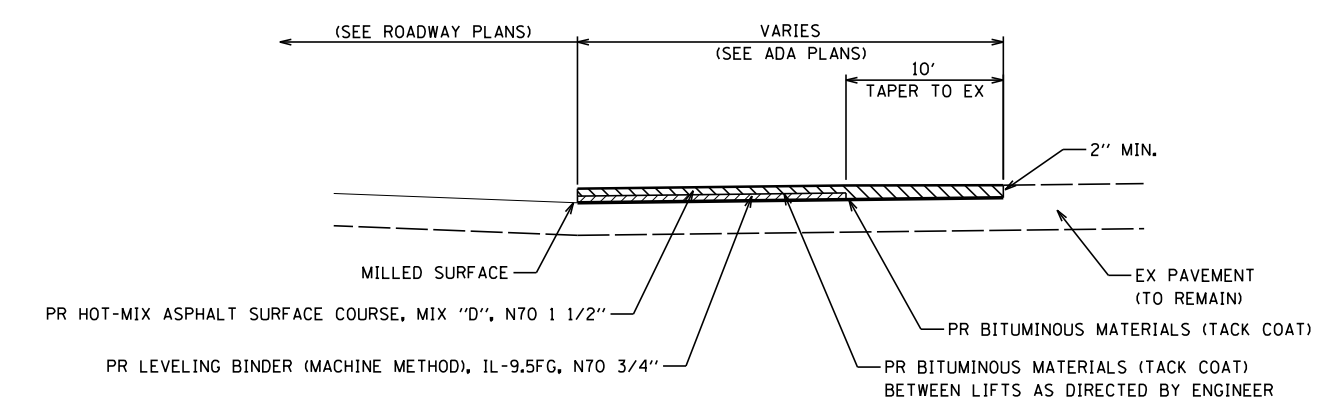

SIDE ROAD TYPICAL SECTION DETAIL
NOT TO SCALE

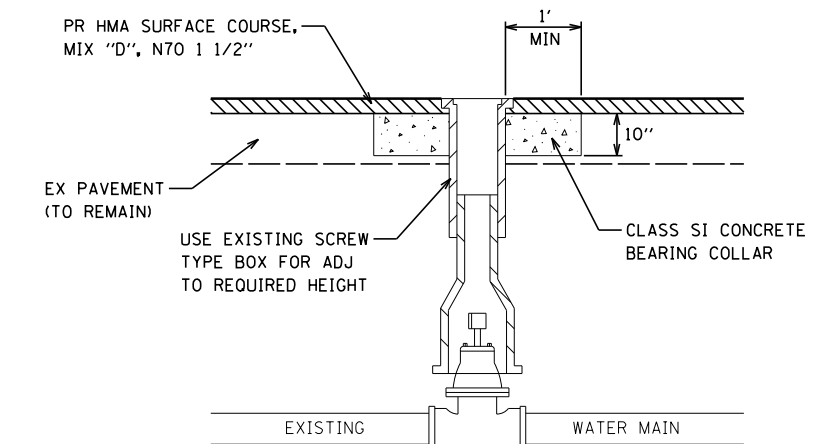

VALVE BOX FRAME TO BE ADJUSTED DETAIL
NOT TO SCALE

BENTON & ASSOCIATES, INC.

FILE NAME =	USER NAME = \$USER\$	DESIGNED -	REVISED -
P:\10e2166-34\FAP 103 (IL 13-IL 15) Sec 12	25,38,561RS 76J16\CADD Sheets\0876J16-sh-t-d	DRAWN - MGM	REVISED -
Default	PLOT SCALE = 40.0000' / in.	CHECKED - WJS	REVISED -
	PLOT DATE = 2/25/2019	DATE - 2/2019	REVISED -

**STATE OF ILLINOIS
DEPARTMENT OF TRANSPORTATION**

**CONSTRUCTION DETAILS ADA SIDEWALK (FREEBURG)
FAP ROUTE 103 (IL RTE 13 /15)**

SCALE: SHEET 25 OF 25 SHEETS STA. TO STA.

F.A.P. RTE.	SECTION	COUNTY	TOTAL SHEETS	SHEET NO.
103	(27,25,38,56)RS	ST. CLAIR	87	76
CONTRACT NO. 76J16				
ILLINOIS FED. AID PROJECT				