

PLAN VIEW
APPROACH SLAB OR SHOULDER PLACEMENT

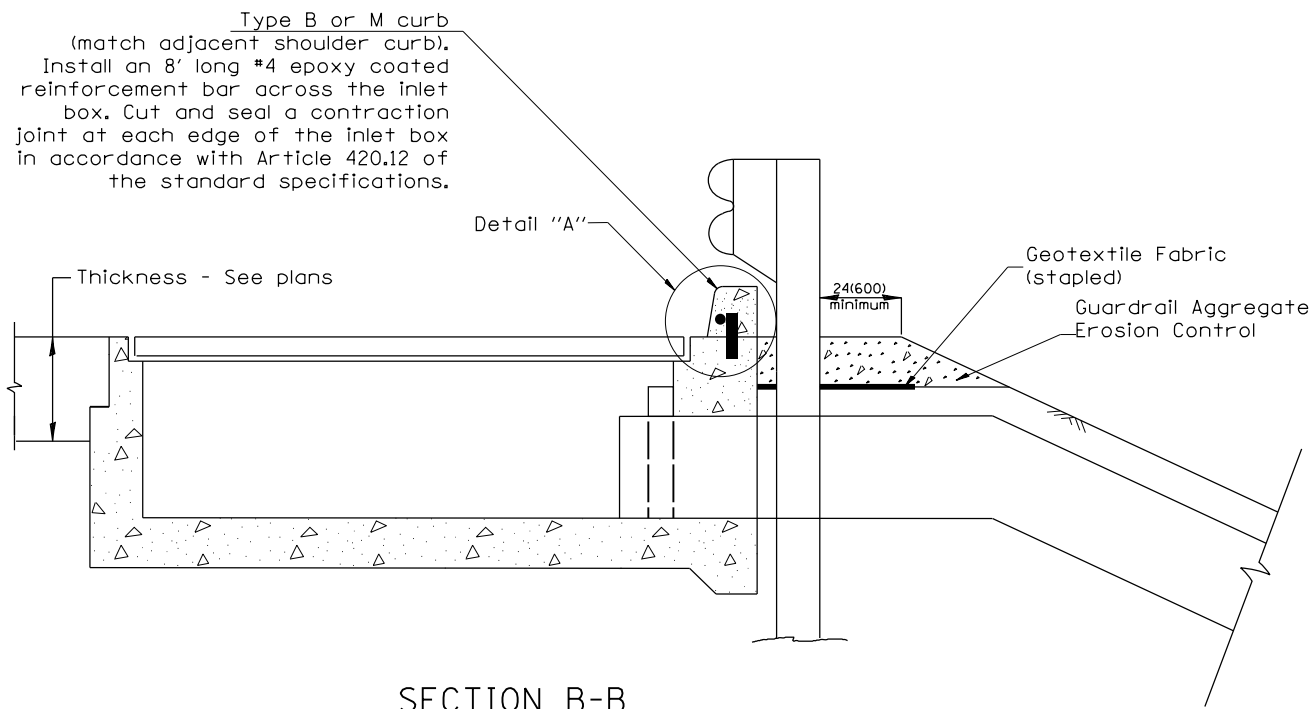

SECTION B-B
TYPICAL SECTION AT INLETS
TYPE E, F & G (HIGHWAY STANDARD 610001)

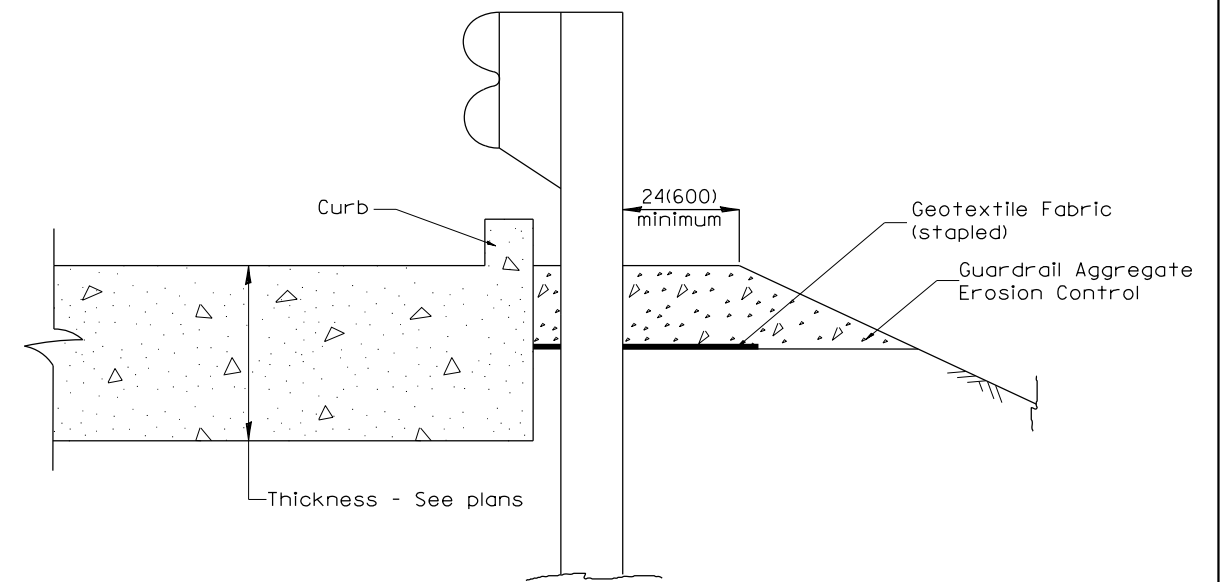

SECTION A-A
TYPICAL SECTION WITH BRIDGE APPROACH CURB

All dimensions are in inches (millimeters) unless otherwise noted.

STATE OF ILLINOIS				GUARDRAIL EROSION CONTROL TREATMENTS				F.A.P. RTE.	SECTION	COUNTY	TOTAL SHEETS	SHEET NO.
DEPARTMENT OF TRANSPORTATION				NOT TO SCALE				22	48(B-1)BR(CR)	KNOX	94	70
SHT. 2 OF 2								CONTRACT NO. 68758				
CADD STD. 630101-D4								FED. ROAD DIST. NO. ILLINOIS FED. AID PROJECT				